



Innovation for sustainable accelerators systems (iSAS)

M. Baylac (CNRS-LPSC)

J. D'Hondt (Nikhef), J. Knoblock (HZB), C. Pira (INFN), A. Stocchi (CNRS-IJCLab) on behalf of iSAS consortium



Work supported by funding from European Union's program EU HORIZON-INFRA-2023-TECH-01-01 under GA n°101131435



Introduction

- Particle accelerators are exceptional instruments (research, applications), but in a context of energy savings and sustainability
 - **minimizing the energy consumption of future accelerators is an unavoidable challenge**, underlined by the ESPP (2020)
- EU call dedicated to **“New technologies and solutions for reducing the environmental and climate footprint of Research Infrastructures”** (HORIZON-INFRA-2023-TECH-01)
 - **Project « Innovate for Sustainable Accelerating Systems (iSAS)» approved and launched in 2024**
 - Scientific coordinator J. D’Hondt (Nikhef), project coordinator A. Stocchi (CNRS-IJCLab)
- **Ressources and partners**
 - Total project budget of ~13 M€ with ~5 M€ funded from Horizon Europe
 - HR ~1000 person-months spread over 4 years
 - Partners : 12 laboratories/institutes and 6 industrial companies
- **Goals of this talk**
 - **How to tackle the topic of energy savings? → scope and status**
 - **How to quantify ? → energy saving metric**
- **Not specifically dedicated to heavy ions**

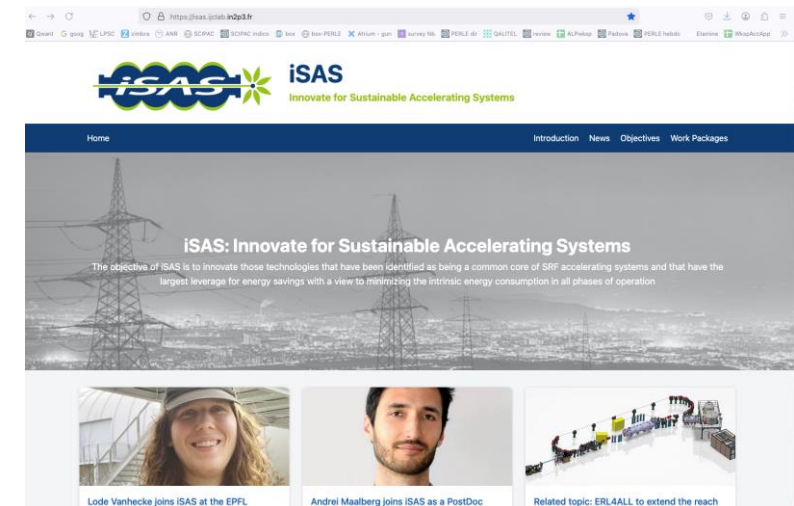

<https://isas.ijclab.in2p3.fr/>

- **Breakdown of power consumption of accelerators for different subsystems**
 - Depends upon the type of machine (circular, linear, ..)
 - Example of electron-positron Higgs factory

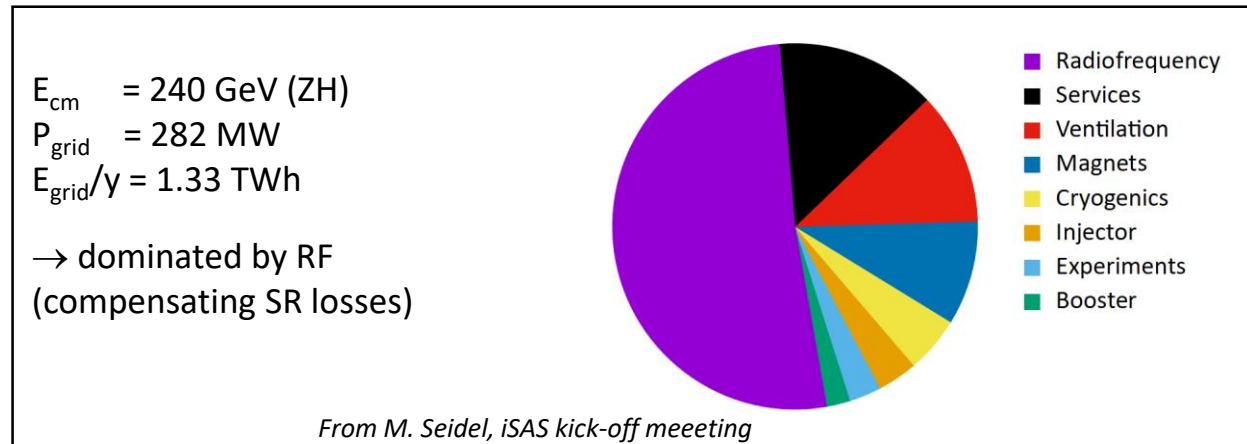

For FCC-ee

[1] FCC CDR, Eur. Phys. J. Special Topics 228, 261–623 (2019)

- **iSAS will largely concentrate on the energy savings from the RF**
 - Complementary to meaningful programs for energy savings on high efficiency magnets, high efficiency RF sources, reuse of RF heat ...
- **Two axes of iSAS**
 - **Development** of the energy savings technologies for accelerators
 - **Implementation** of the technologies at different levels
- **Main focus on the 3 ESFRI Research Infrastructures : HL-LHC, ESS and EuXFEL**
 - Developed technologies potentially to be used on various SRF applications

- **Multiple sources impacting the grid-to-beam power efficiency :**

- RF power source efficiency : η_{RF}
- RF load by detuned cavities
- Cavity cryogenic loss : $P_{loss} \propto 1/Q_0$
- Generation of cryogenics (coefficient of performance) : COP
- Loss of the beam power : P_{beam}

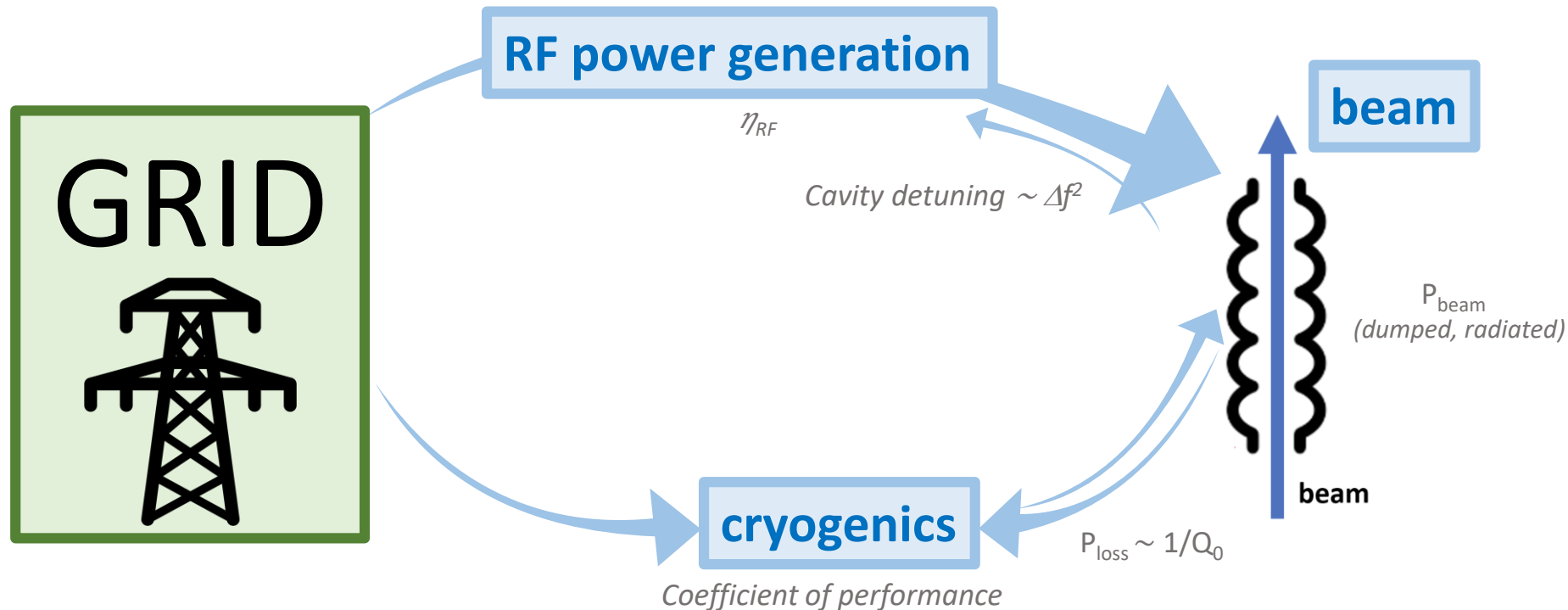

Sources of power inefficiencies and mitigations

- Multiple sources of power in-efficiency can be addressed by mitigation technologies

- RF power source efficiency : η_{RF} → amplifier with enhanced efficiency (e.g. solid state technology)
- RF load by detuned cavities → dealing with microphonics to reduce Δf → iSAS technology area (TA#1)
- Cavity cryogenic loss : $P_{loss} \propto 1/Q_0$ → improve quality factor of the cavity Q_0 → iSAS technology area (TA#2)
- Generation of cryogenics : COP → increase the operating temperature of the cavity (T) → iSAS technology area (TA#2)
- Loss of the beam power : P_{beam} → recover the energy of the beam (Energy Recovery Linac) → iSAS technology area (TA#3)

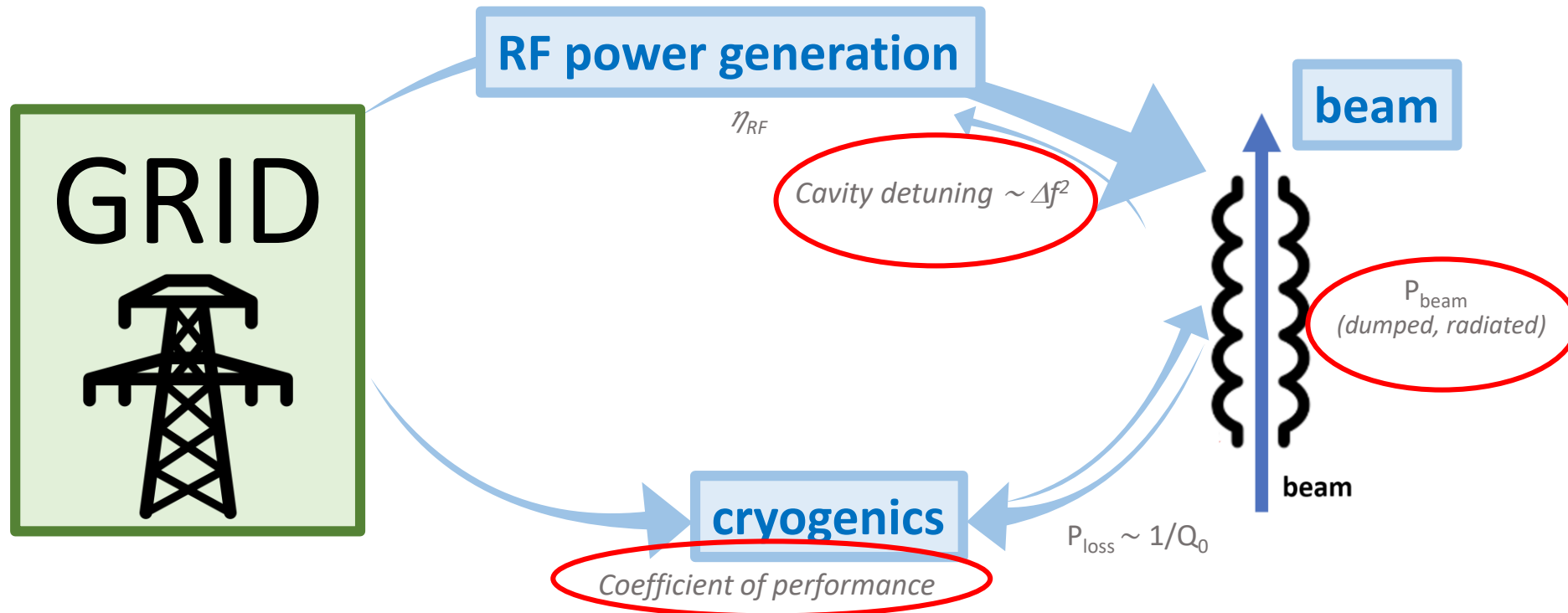



Scope of iSAS

- **Development of 4 technologies**

- WP1 : Ferro-Electric Fast Reactive Tuners (FE-FRT)
- WP2 : Smart Low Level RF controls (LLRF)
- WP3 : Nb₃Sn on Cu films for 4.2 K cavity operation
- WP4 : Couplers, Fundamental and Higher Order modes

➔ **Technology Areas (TA)**

- (TA#1)
- (TA#1)
- (TA#2)
- (TA#3)

- **Implementation of these 4 Technology Areas**

- WP5 : In the design of a new energy-saving cryomodule
- WP6 : In current and future research infrastructures accelerator
- WP7 : Into industrial solutions

➔ **Integration Activities (INT)**

- (INT#1)
- (INT#2)
- (INT#3)

March 2025

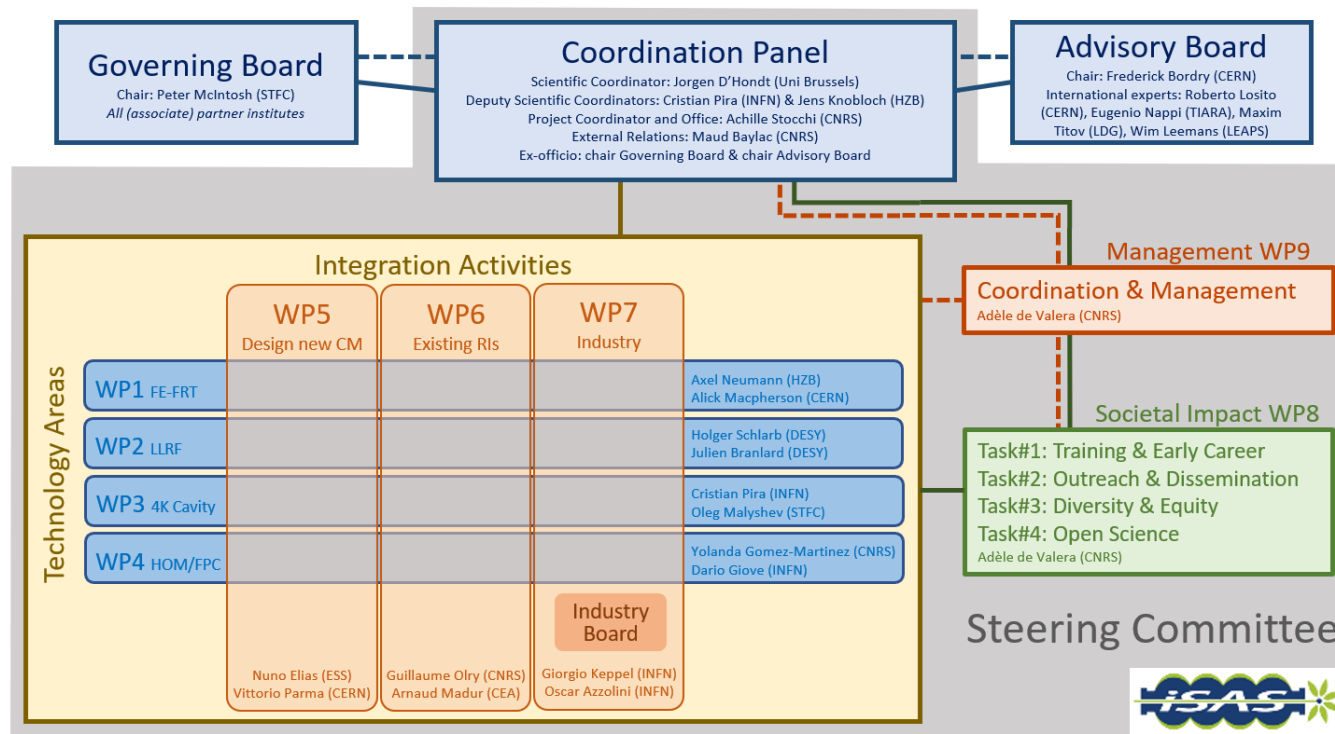



Energy saving metric

- For the technologies developed within iSAS : **how to quantify the energy savings of these technologies ?**
 - **Metric limited to operational power (cost)**
 - **Keep it simple**
- **We compare the power consumption with and without the « iSAS technology » in similar conditions**
 - Measured (or expected) wall plug power consumption : kW
 - Comparison of the consumption with and without the iSAS technology/device/options
 - Conditions : the use case to be specified for each technology
- Definition of the metric
 - Proposed by the WP leaders, validated by the advisory board (March 2025)
 - Definition of the metric is a deliverable of the project (May 2025)

FE-FRT (TA#1) : scope

WP1 leader : A. Neuman (HZB)

- **Goals : reduce the large RF power overhead required to**
 - Compensate the detuning induced by mechanical vibrations
 - Control the transient beam loading
- **WP1 : Develop novel fast tuning system, Ferro-Electric Fast Reactive Tuners (FE-FRTs)**
 - FE-FRT tuner : alternative to classic mechanical cavity tuner
 - Couple a tunable device to the cavity to change the frequency of the coupled system
 - HV applied to FE material with tuneable dielectric constant (BST: Ba, Sr, Ti) to change its permittivity
 - Impedance change controls the resonance frequency of the coupled system
 - Based on previous work by CERN, Lancaster, BNL and Euclid techlabs
 - Partners: [HZB](#), CERN, CNRS, Univ. Lancaster

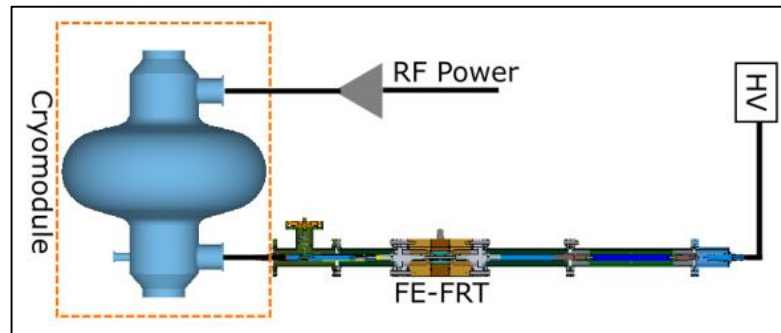

FE-FRT coupled to a cavity

Fast tuning response ~ 100 ns
Tuning range \sim tens of kHz

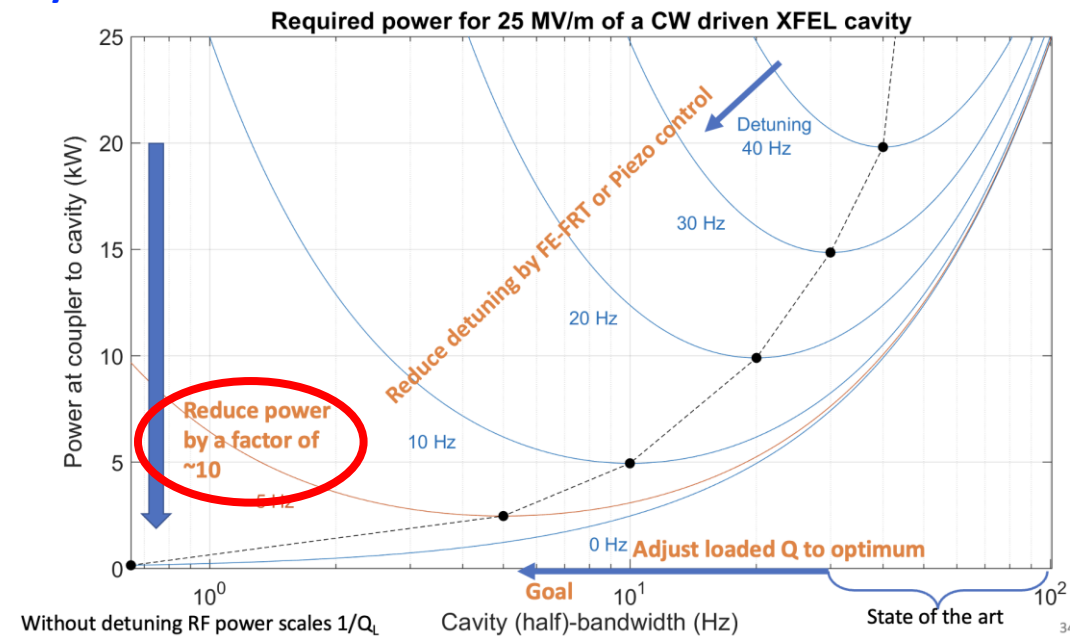

Required power for a number of detuning scenarios as a function of the cavity (half)-bandwidth for an EuXFEL cavity operated at 25 MV/m



FE-FRT (TA#1) : status

WP1 leader : A. Neuman (HZB)



- **Status**
 - ferro-electric material characterisation is ongoing
 - Material characterisation
 - High voltage breakdown tests
 - design efforts ongoing : RF power requirements from 100's W to kW's
 - potential use cases being explored, e.g. for FCC (connected to PERLE at 800 MHz)
 - **FE-FRT workshop, Nov 13-14, 2025, at Berlin (HZB) : <https://events.hifis.net/event/2275/>**

➔ iSAS is a catalyser bringing the FRT community together and enhance developments for a broader set of applications

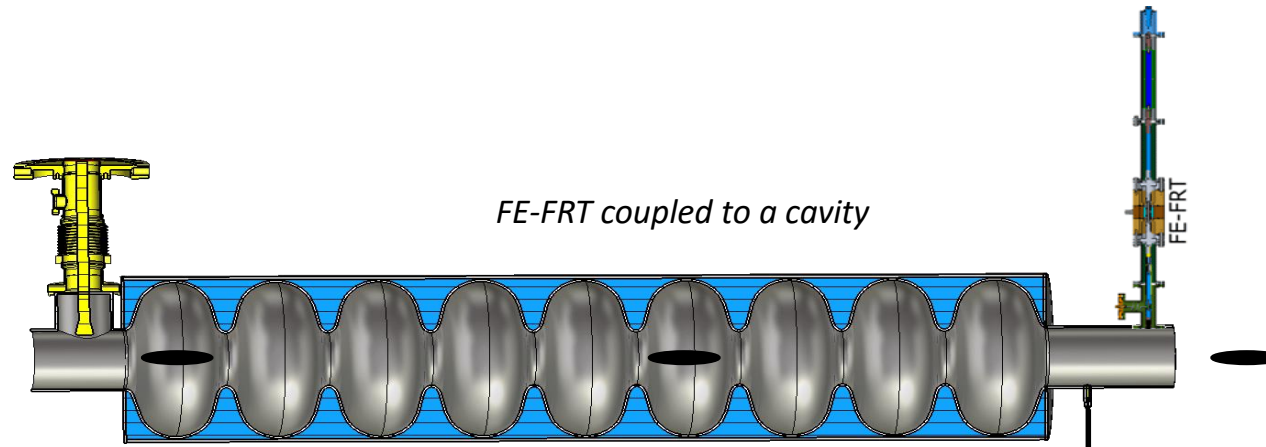



FE-FRT (TA#1) : metric

WP1 leader : A. Neuman (HZB)

- The metric to estimate the savings is the
 - **invested RF power to drive the cavity at a given field for microphonics compensation, which will have to be converted to wall-plug power**
- The study case : **TESLA cavity (1.3 GHz) in CW mode at 16-20 MV/m operated with FE-FRT or piezo tuner**
 - **Reference test 1: Operation at a typical, conservative loaded quality factor of e.g. $1 \cdot 10^7$ with piezo control**
Measure microphonics detuning, level of microphonics detuning, field stability with LLRF system, power
 - **Reference test 2: Repeat the first test by tuning the coupler to higher loaded Q of $5 \cdot 10^7$ with piezo control**
Validate the beforehand measured parameters
 - **FE-FRT demonstration: Operate the cavity with FE-FRT and demonstrate micro-phonics detuning compensation and reachable, field stable, highest loaded Q.**
Measure the **RF power level** and dissipated power in FRT (temperature sensors)

Smart LLRF (TA#1) : scope

WP2 leader : J. Branlard (DESY)

- **Goals : reduce the required RF power by efficient field control and detuning control with Low Level Radio Frequency (LLRF)**
 - Several factors of the LLRF tuning system impact the energy consumption : coupling, shape of modulator, amplifier ...
 - Operation at higher Q_{ext} (narrower bandwidth Δf)
 - Reduces the power needs **ONLY IF** resonance control can be guaranteed
 - But makes resonance control extremely challenging
 - **Challenge : find the highest Q_{ext} while meeting resonance control goals and without compromising operability or reliability**

EU-XFEL : How shaping the modulator pulse can save power
 → LLRF development to compensate introduced non-linearities

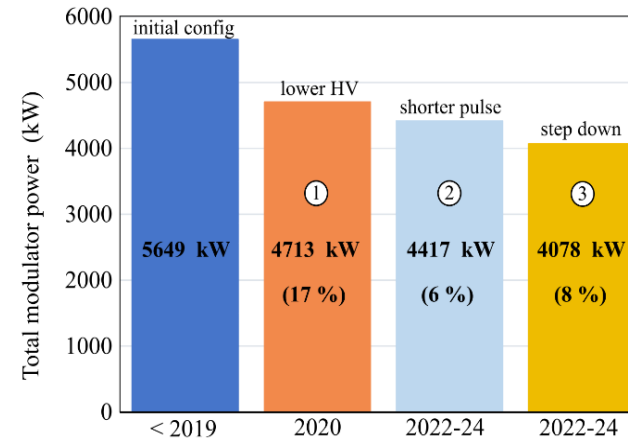
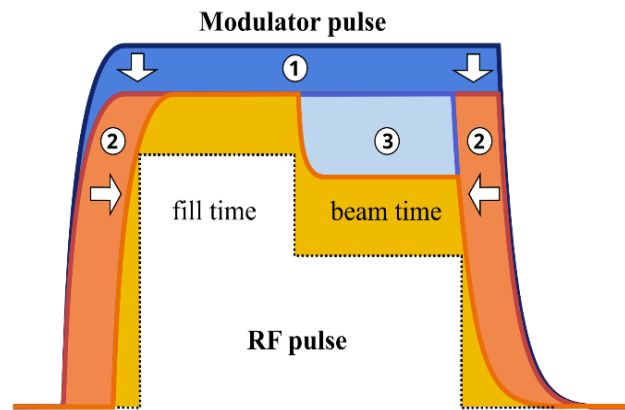

Power savings > 1.5 MW

“RF-based energy savings at the FLASH and European XFEL LINACs”, J.Branlard et al. in proc. of LINAC 2024

- **WP2 : demonstrate the operation of a digital LLRF system, integrating AI, for optimum control of field and detuning**
 - Partners: [DESY](#), [CNRS](#), [HZB](#)

• Status

- **Development of 2 prototypes (DESY) with iris tuner**
 - Extending the Qext range
- **Vibration analysis**
 - Deep learning of cavity detuning under study at HZB
- **Optimizing the Lorentz force detuning at EuXFEL**
- **Roadmap to integrate FE-FRT in the LLRF**
 - link with WP1

Iris-tuner (variable)

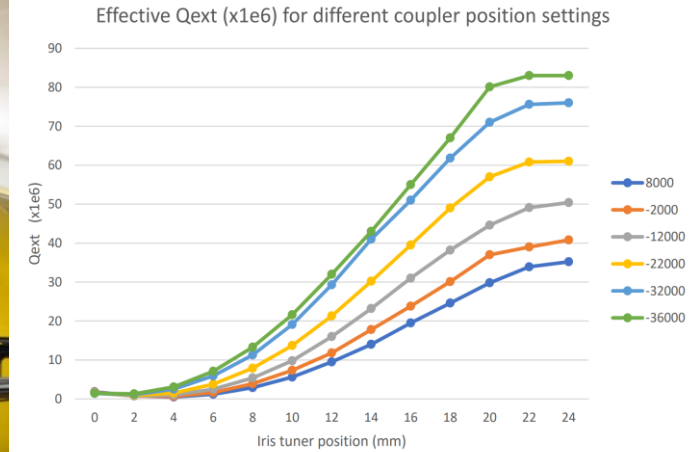



Smart LLRF (TA#1) : metric

WP2 leader : J. Branlard (DESY)

- LLRF cannot be switched for the sake of comparing power consumption
 - Yet different options of the LLRF system can be turned ON/OFF or adjusted → several metrics

Metric	How to measure
Instantaneous AC consumption	Measure the <u>accelerator AC consumption</u> with and without the applied LLRF optimization for a direct comparison. This can be measured at the <u>modulators</u> for example.
RF power usage	Compare the <u>peak and the integrated forward RF power</u> with and without the LLRF optimization.
AC-to-RF efficiency	Compute the <u>AC-to-RF efficiency of the high-power source</u> (i.e. SSA) with and without optimized working point by the LLRF
Accelerator up-time, or trip recovery time	<u>Provide examples where the accelerator up-time or trip recovery time</u> has been improved following the implementation of the LLRF supervisory control and fault diagnostics.

- Study case
 - Different facilities offer different test options (CW, pulsed, presence of beam, narrow bandwidth cavities ...) : DESY, CNRS, HZB



4 K cavities (TA#2) : scope

WP3 leader : C. Pira (INFN)

- **Goals : reduce the necessary cryogenics power with**
 - Higher critical temperature T_c material allows operation at 4.2 K instead of 2 K while maintaining high Q_0 and E_{acc}
 - Expected reduction of cost of operation : factor of 3
 - **WP3 : Explore coatings of Nb_3Sn on Cu in order to**
 - **Minimize flux trapping**
 - **Increase mechanical strength of the coating to allow better cavity tunability**
 - Partners: [INFN](#), CEA, HZB, UKRI
- **Complementary to the EU project I.FAST WP9, aim to go beyond the achievements of I.FAST WP9**

Power at 300 K required to extract 1 W at cryogenic temperature

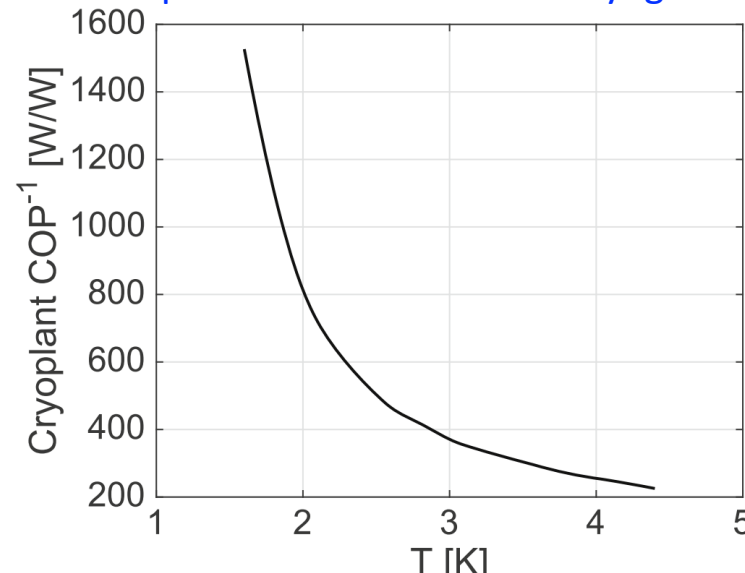

COP 3 times better at 4.2 K than 2 K

→ significant energy saving at 4.2 K



4 K cavities (TA#2) : status

WP3 leader : C. Pira (INFN)

- **Status**
 - **Several facilities upgraded**
 - For material characterization
 - For sample and cavity tests
 - **First tests ongoing for flux trapping**
 - **Nb₃Sn coating systems ready to go**
 - **Several adaptive layers being tested (samples)**
 - first @STFC and later @INFN



The Choke cavity facility (UKRI)

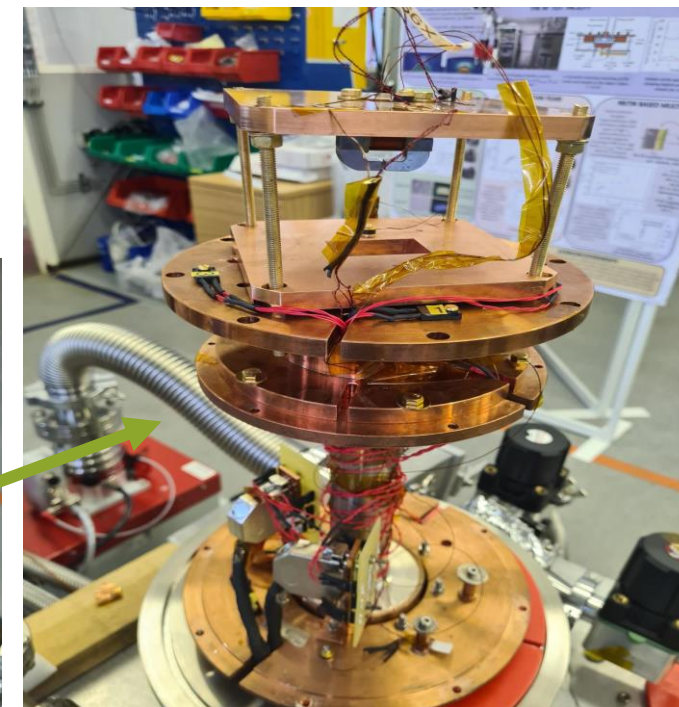
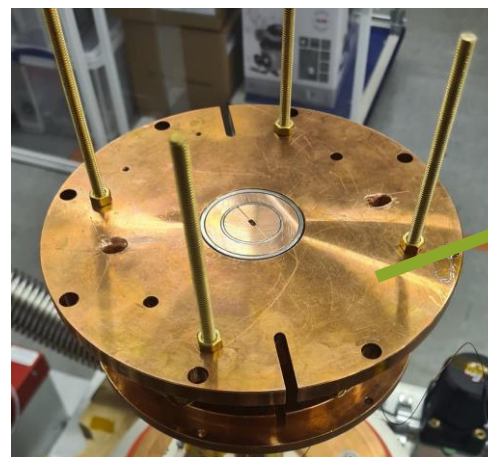

The Field Penetration Facility (UKRI)

4 K cavities (TA#2) : metric

WP3 leader : C. Pira (INFN)

Expected: 0.7 – 3.5 W per cell @ 1 MVm⁻¹ ($R_{res} = 5-30 \text{ n}\Omega$)

- Proposed metric : AC power dissipation of each cavity cell

- P_{acc} per cell @ 1 MV/m

- Methodology

- Measurement of Q_0 vs E_{acc} via an RF test
 - deduce surface resistance R_s via $Q_0 = G/R_s$
 - ($R_s = R_{BCS}(T) + R_{res}$ determines the efficiency of the cavity : $Q_0 \propto 1/R_s$)
- Determine the residual resistance from this surface resistance
 - estimate the grid power of Nb₃Sn at 4K
- Comparison with bulk Nb at 2K at same gradient

- Study case

- QPR data (already available)
- 1.3 GHz cavity baseline by I.FAST
- new cavity optimized at the end of ISAS**

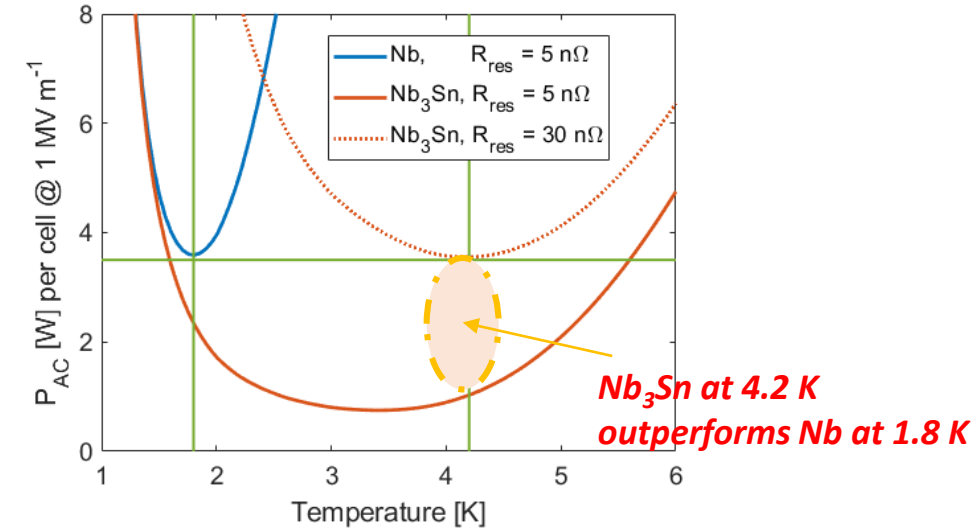

Calculated AC power dissipation of Nb and Nb₃Sn cavity cells at cryogenic temp. 1.3 GHz.

C. Antoine et al., "Thin-film SRF roadmap", I.FAST deliverable report D9.1, 2025. doi:10.5281/zenodo.14731411

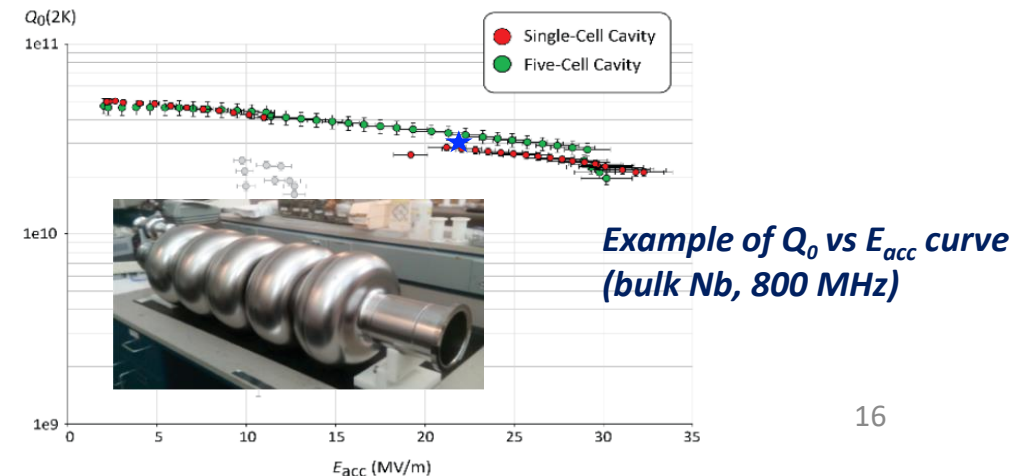



Couplers (TA#3) : scope

WP4 leader : Y. Gomez Martinez (CNRS-LPSC)

- **Goals : reduce the heat loads of the cryogenics by**
 - **reducing the power deposited by the Fundamental Power Coupler, Higher-Order Mode coupler and Beam Line Absorber**
 - FPC : coupler to introduce the power to excite the fundamental mode of the cavity (antenna)
 - HOM : coupler used to damp the HOM trapped in the cavity
 - BLA : used to damp HOM propagating through the beam pipes by directly absorbing their power

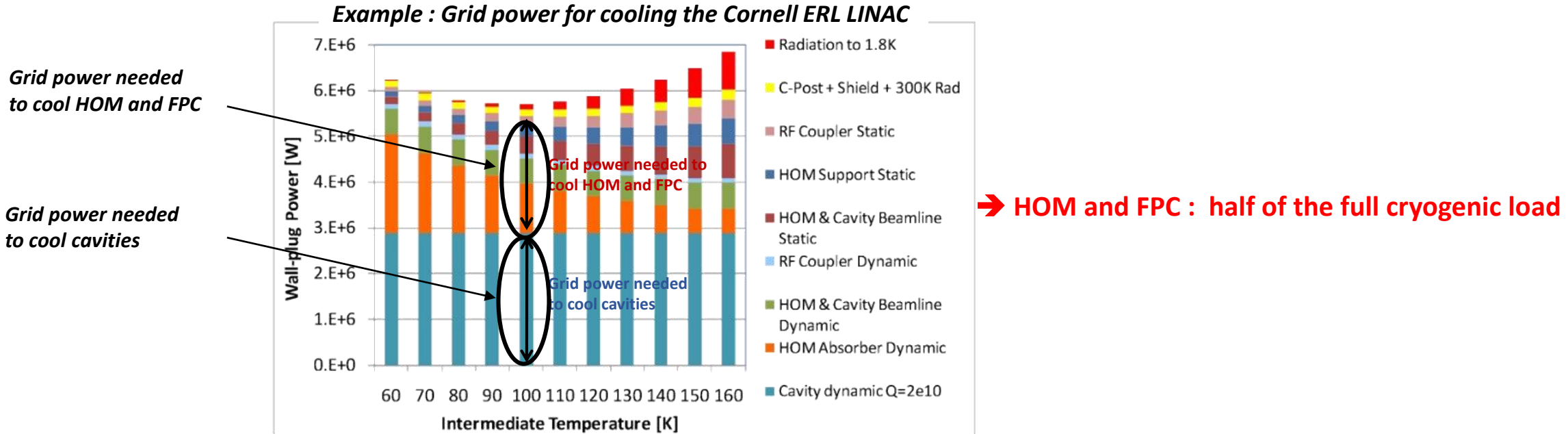

Figure adapted from "Cornell Energy Recovery LINAC Project Definition, Design Report", G Hoffstatter, S. Gruner, M. Tigner, eds. (2013)

- **WP4 : Design & build prototypes for integration and test in accelerator-like conditions in a cryomodule (energy-recovery PERLE)**
 - Partners: [CNRS/LPSC](#), [INFN](#), [CERN](#)

Couplers (TA#3) : status

WP4 leader : Y. Gomez Martinez (CNRS-LPSC)

- **Status of HOM coupler**
 - optimal geometry selected and optimized (800 MHz)
 - ➔ reduced number of HOM couplers required per cavity (2)
- **Status of Fundamental Power Coupler (FPC)**
 - Design : from SPL project (CERN)
 - Adaptation underway for the mechanical integration in the PERLE cryomodule
 - HV conditioning protocole under discussion



Hook coupler

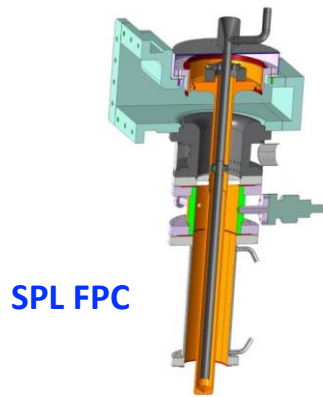
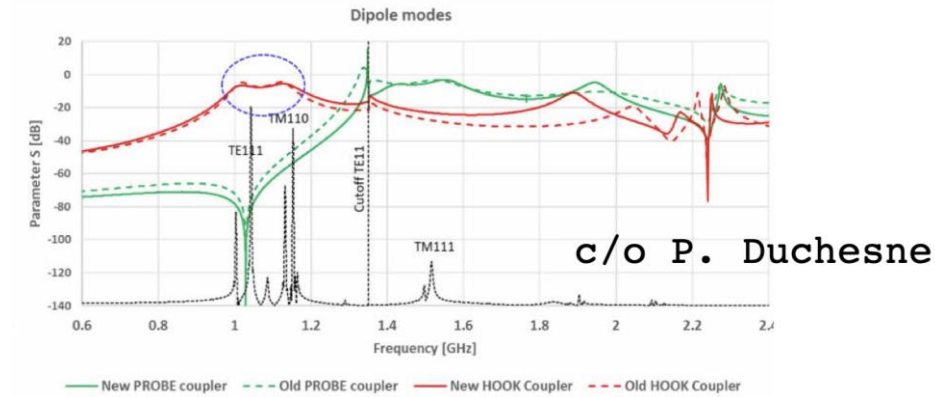
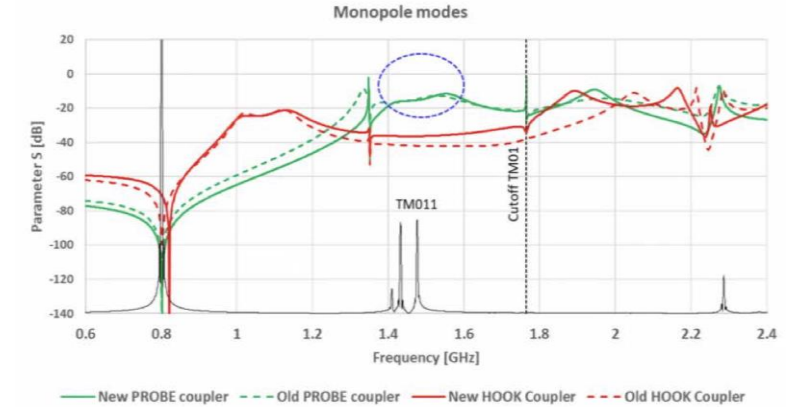

SPL FPC

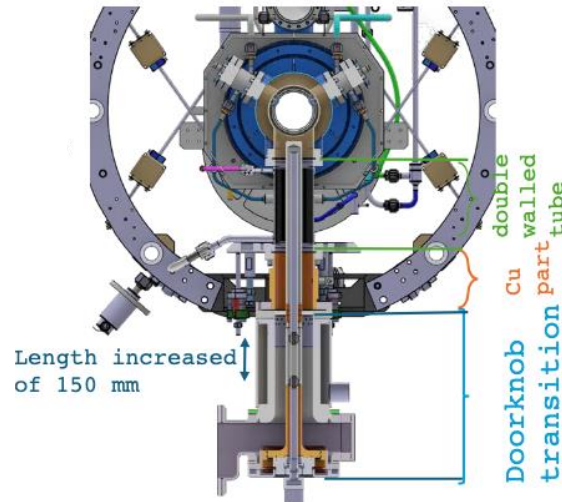

FPC proposed in the WP6 cryomodule

c/o S. Blivet & G. Olivier



Input from data of ESS cryomodule Coupler cryoline

- Thermal calculations, with the existing design of the ESS cryomodule
 - Cooling power consumption performed from the ESS data by CERN
 - Under study : ESS cryomodule data indicate ~9 K inlet temperature to FPC, whereas design value is 5K
 - the major consumption comes from the inlet line to the couplers
- ➔ in addition to design of the FPC itself, special care must be given to the cryoline towards the coupler

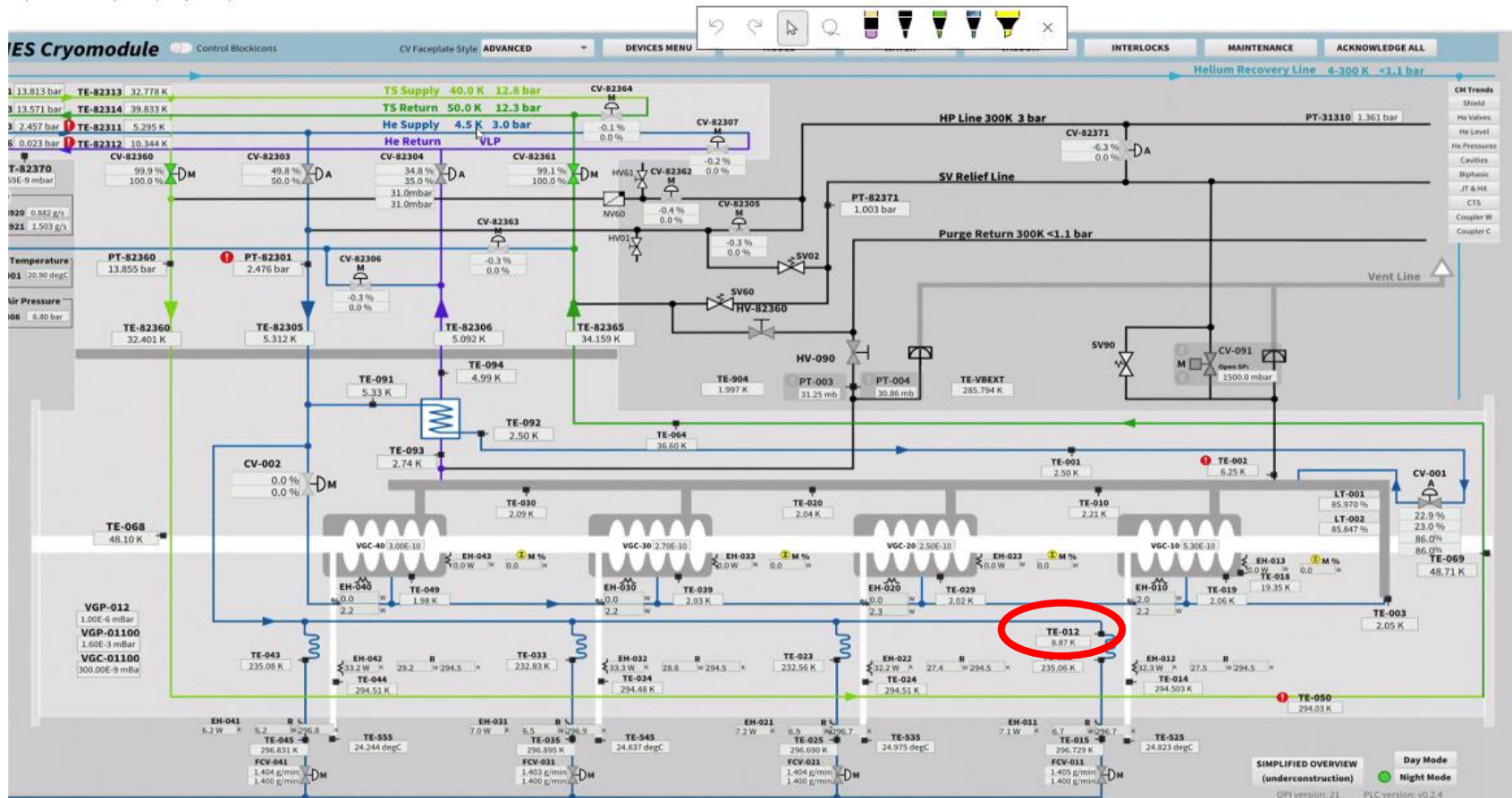

Under study

From N. Elias (ESS)

Couplers (TA#3) : metric

WP4 leader : Y. Gomez Martinez (CNRS-LPSC)

- **FPC : calculation of the electrical power consumption, with existing coupler design**
 - Comparison between cooling regime (turbulent/laminar) with existing design (CERN)
 - Electrical consumption considering the inlet line to the couplers with feedback from ESS (CERN)
 - Comparison between a two-loop design (50 K & 5 K) and the **current one-loop design** (IJCLab)
- **HOM : calculation of the electrical power consumption and comparison of 2 cooling options**
 - **HOM cooled at 2 K (current design)**
 - HOM cooled at 5 K with an additional circuit
- **BLA : calculation of the electrical power consumption and comparison of 3 cooling options (under study)**
 - BLA at 300 K
 - BLA cooled at 50 K
 - BLA cooled at 50 K with thermalization at 5 K

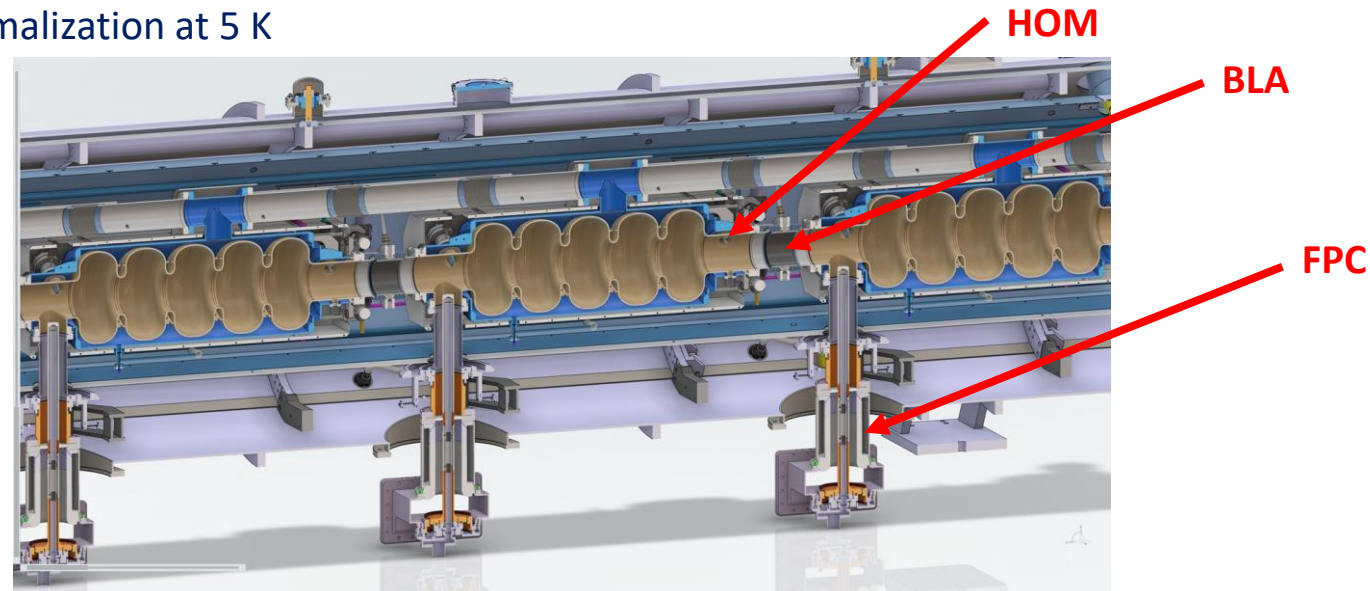



Cryomodule design

WP5 leader : N. Elias (ESS)

- **Goal : Implementation of technologies in the design of a new energy-saving cryomodule**
 - **Address common engineering issues to integrate the iSAS technologies in a parametric cryomodule design**
- **Partners : ESS, CNRS, CERN, INFN, EPFL**
- **Status**
 - **Lessons learned from ESS are being compiled**
 - **Survey launched to benchmark the performance across facilities**

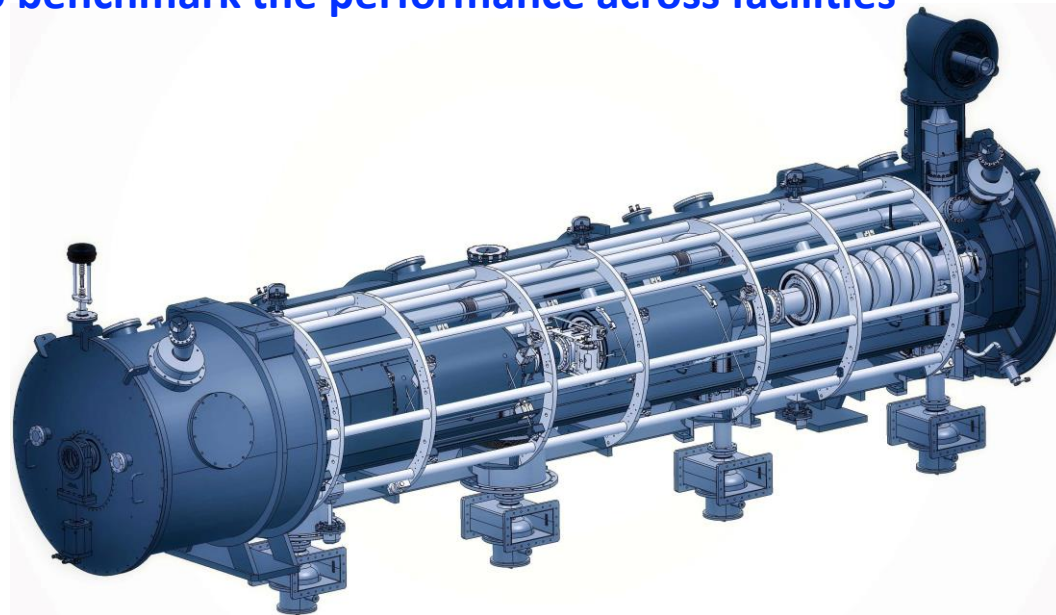

GOAL:
minimize the operational energy cost



Retrofit into existing cryomodule

WP6 leader : G. Olry (CNRS-IJCLab)

- **Goal : implementation of technologies in current and future research accelerators to speed up their deployment**
 - **retrofit of iSAS technologies into the PERLE cryomodule** (high current, multi-turn energy recovery linac)
- **Partners : [CNRS/IJCLAB](#), CEA, ESS, INFN, Lancaster University**
- **Status**
 - Design in progress of the iSAS-PERLE cryomodule (WP1 and WP4 feed into WP6)
 - Technical review of design planned



vacuum vessel

existing ESS cryomodule parts

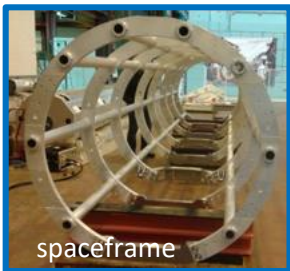

spaceframe



thermal shield

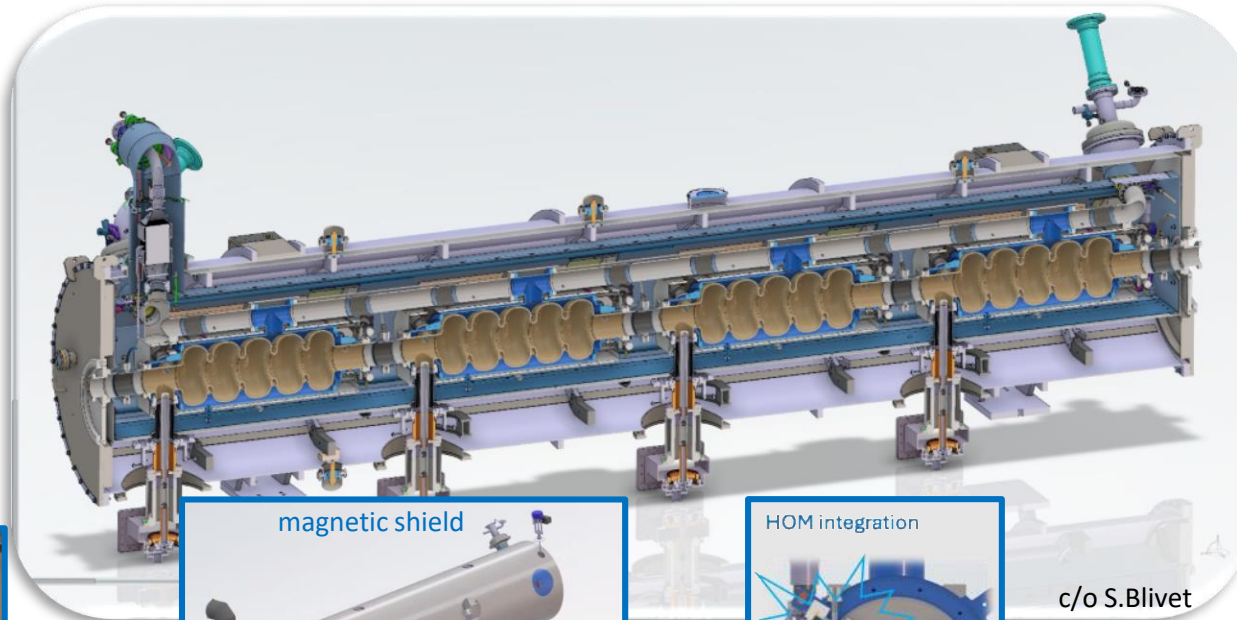

c/o S.Blivet



magnetic shield



HOM integration

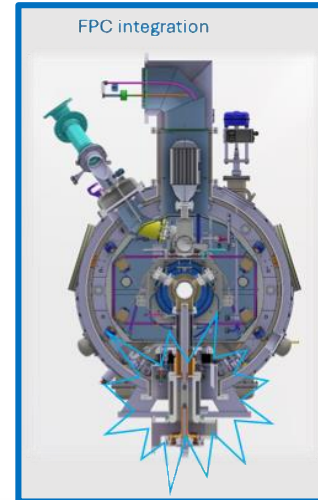

FPC integration

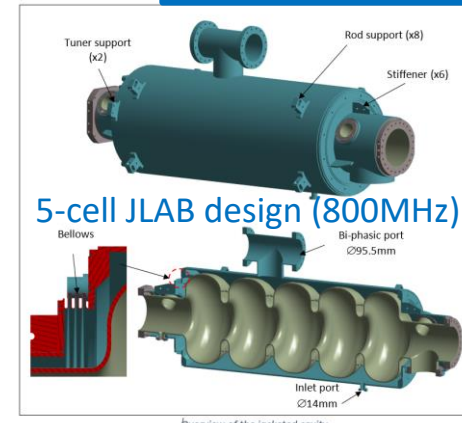

5-cell JLAB design (800MHz)

Overview of the jacketed cavity.

- **Powerful Energy Recovery linac for Experiments (PERLE) at IJCLab (Orsay, France)**
 - **First ERL in the multi-MW regime : electrons, 20 mA, 250 MeV over 3 loops (Pbeam = 5 MW)**
- **Phase 1 - ERL 1 tour : 20 mA, 89 MeV (Pbeam = 1,8 MW) under construction**
 - **Cryomodule of iSAS will be tested at PERLE**
- **Consumption model of PERLE will be developed to determine the accelerator efficiency and compare to classical solutions**

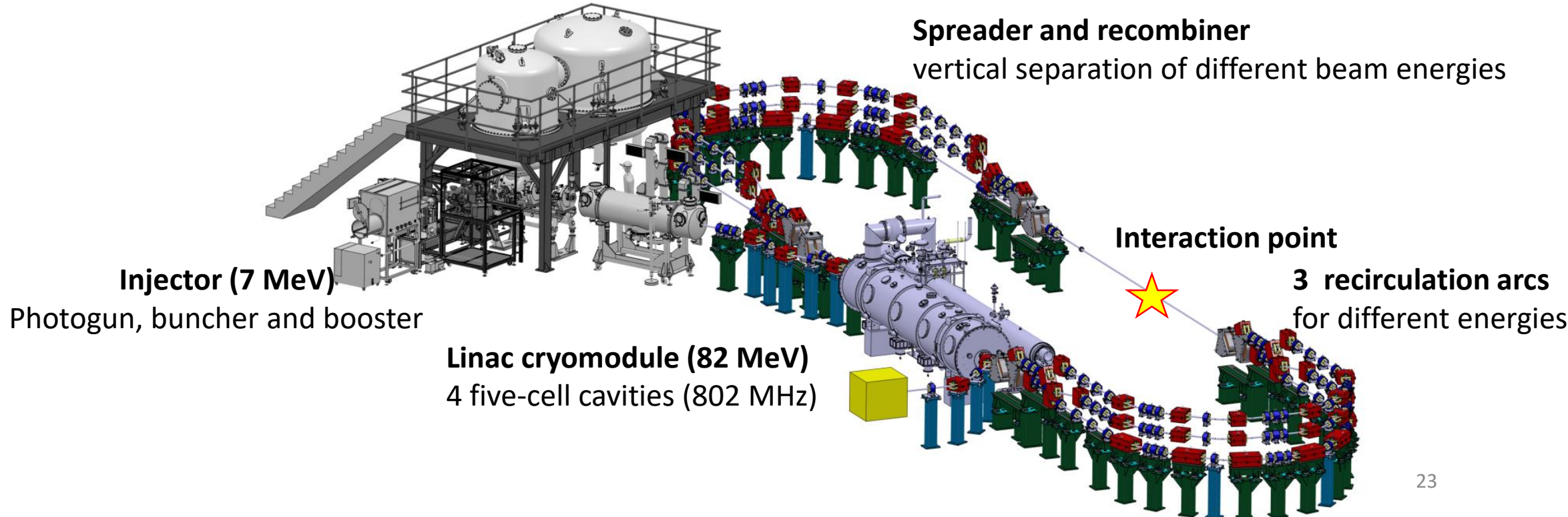



Implementation into industrial solutions :

WP7 leader: G. Keppel (INFN)

- **Goal : Establish and foster the relations with industry towards co-development**
- **WP7 :**
 - engage with industry in the early phases of the R&D
 - increase the Technology Readiness Level (TRL) of iSAS developments
 - opportunities for dissemination
- **Partners : [INFN](#), CNRS**



iSAS

Innovate for Sustainable Accelerating Systems

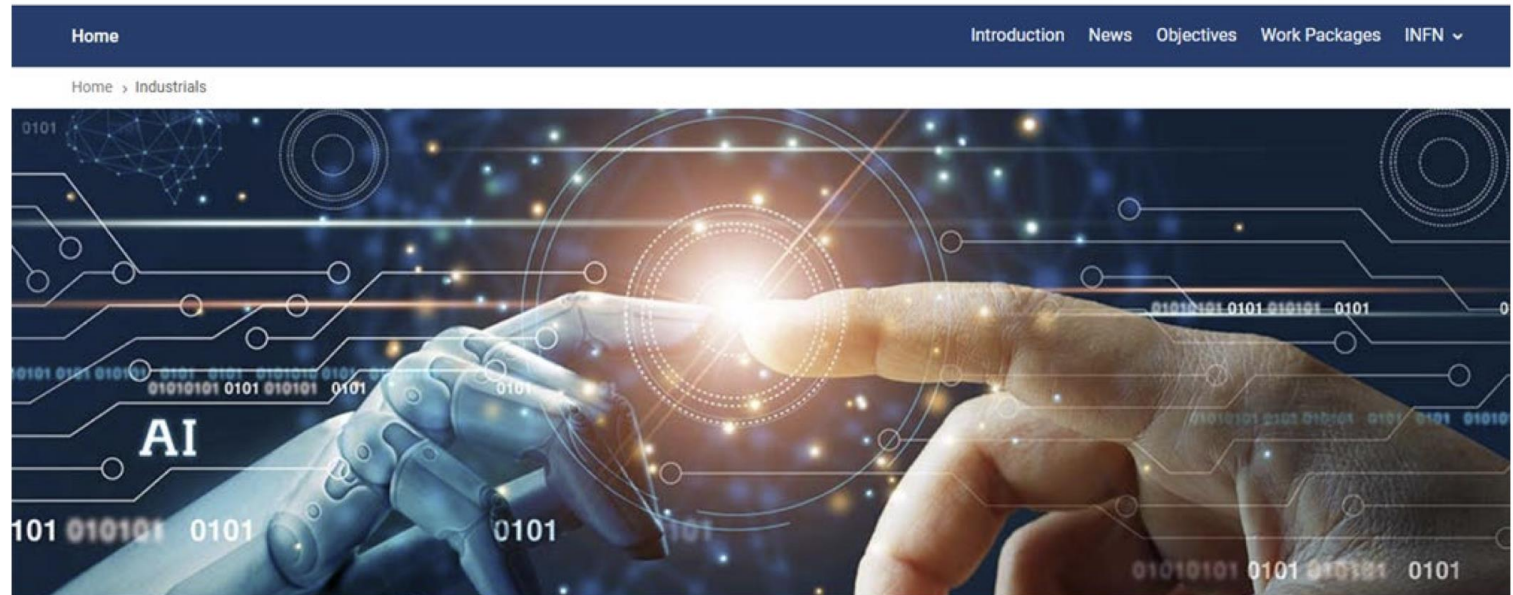



Conclusions

- With iSAS, impactful technologies will be developed, validated and integrated with a direct impact on current research infrastructures and their upgrades
- Energy saving metric defined, will be measured/determined by the end of the project
- On the long term, these technologies aim to reduce the energy footprint of future SRF accelerators by a factor of 2



Thank you for your attention

Work supported by funding from European Union's program EU HORIZON-INFRA-2023-TECH-01-01 under GA n°101131435