

# PERLE cavity development at IJCLab

CNRS/IN2P3/IJCLab

Akira Miyazaki, Patricia Duchesne, Gilles Olivier, Sebastien Blivet, Guillaume Olry

Acknowledgement: SRF cavity team in IJCLab and CEA-Saclay

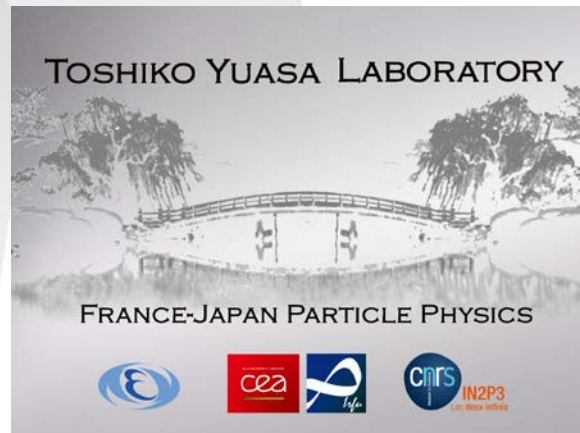



# IJCLab: Low- $\beta$ cavities for protons & heavy ions $\rightarrow$ cavities for electrons



352 MHz

FCC/PERLE cavities (800 MHz)

88 MHz

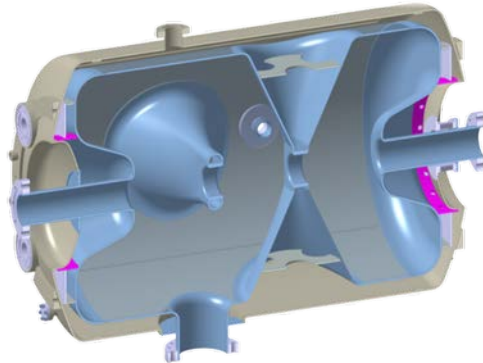

ILC cavities (1.3 GHz)

352 MHz



325 MHz

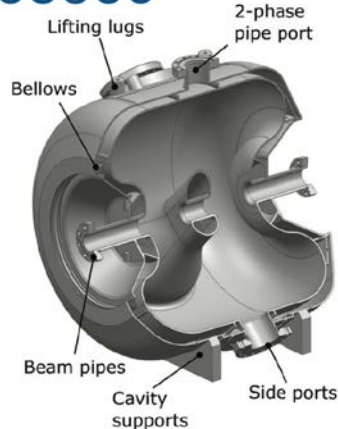
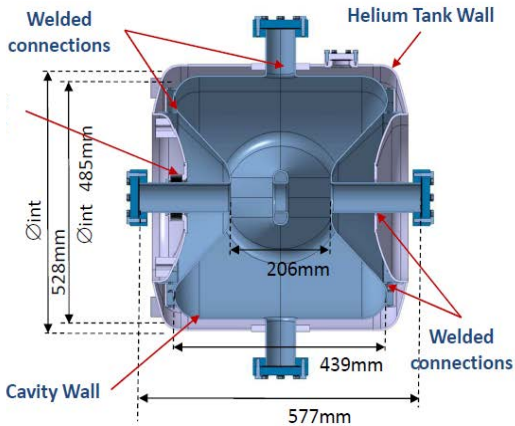
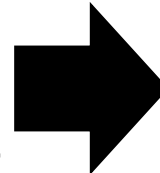



# PERLE project at IN2P3/IJCLab and cavities

Ultimate goal of PERLE: first multi-turn ERL designed to operate at 10 MW (20 mA, 87→250→500 MeV)  
→ A hub to explore a broad range of accelerator phenomena and to validate technical choices improving accelerators for future energy and intensity frontier machines

Target Parameter	Unit	Value
Injection energy	MeV	7
Electron beam energy	MeV	250 / 500
Average beam current	mA	20
Bunch charge	pC	500
Duty factor		CW

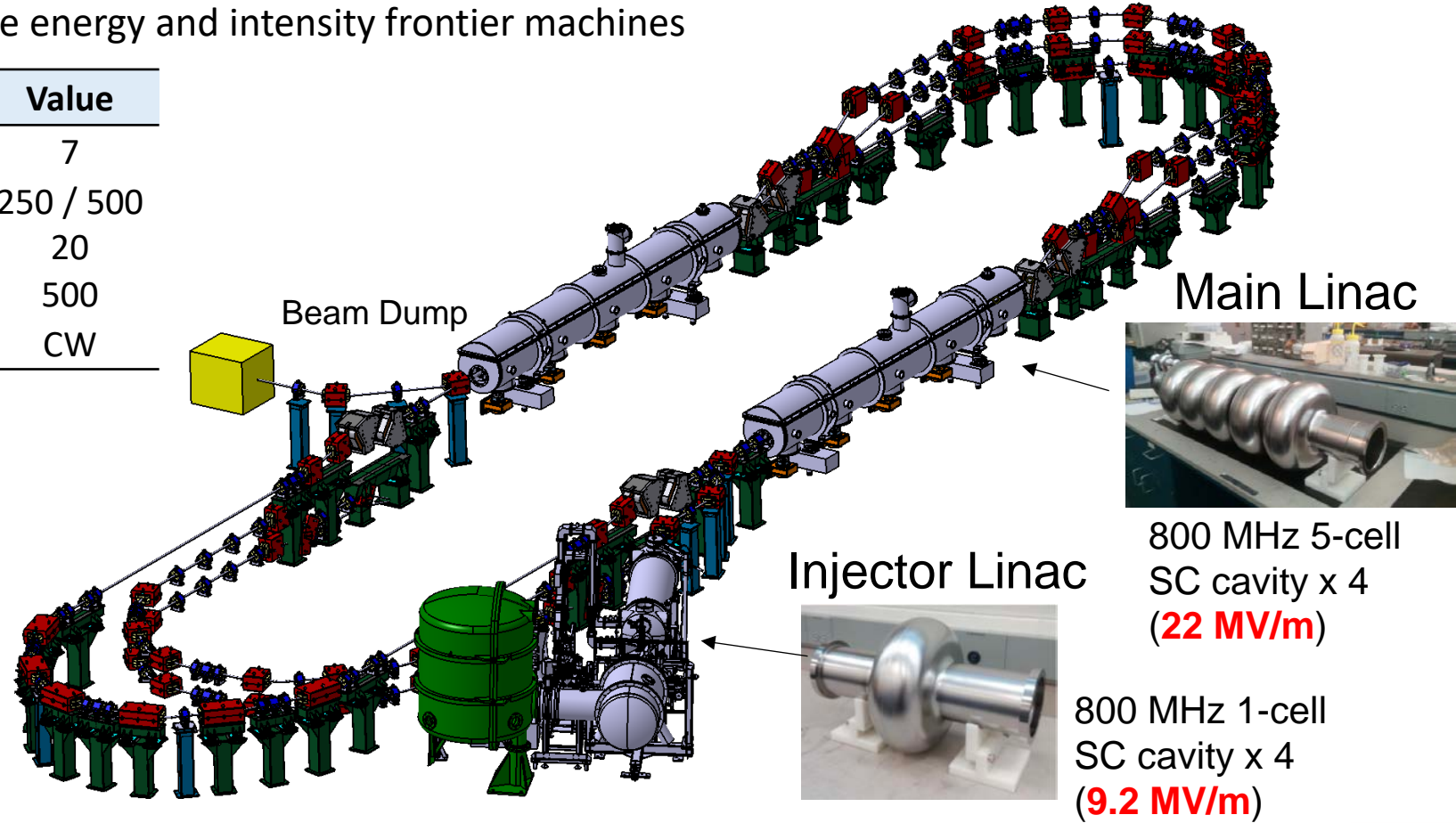
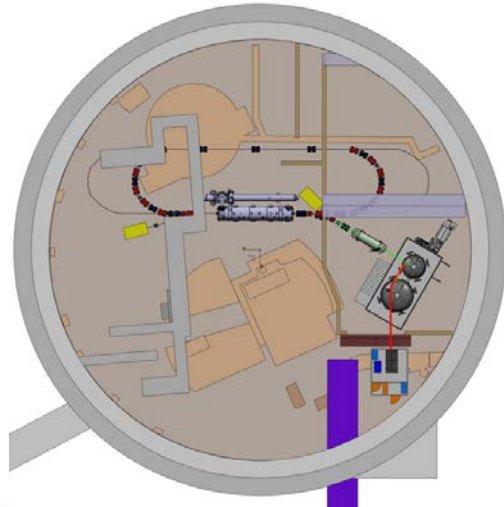



# Experiences from JLAB prototype vs series ESS cavities

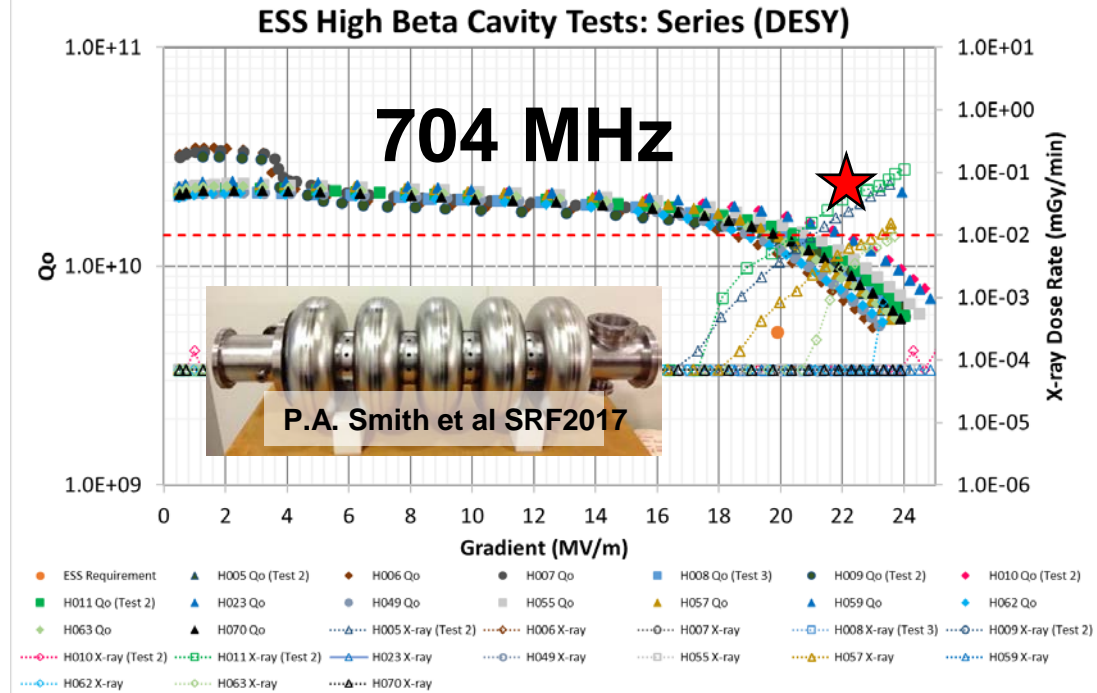
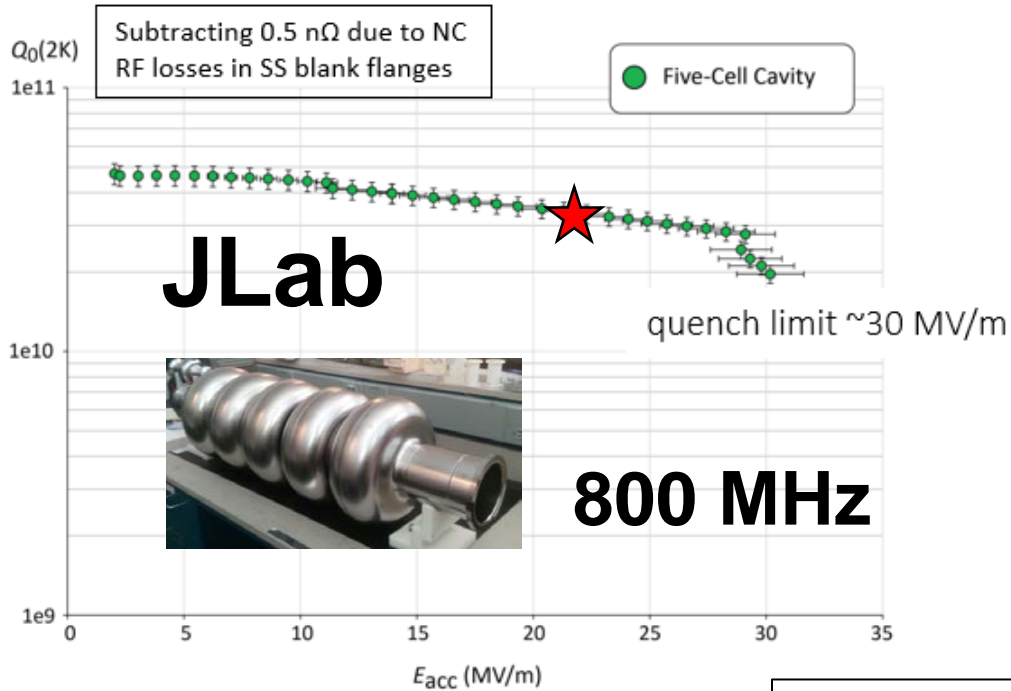

Step	Amount
Bulk BCP	200 μm
800C annealing	3 hours
Final EP	30 μm
120C baking	12 hours

- We will not reach PERLE specification with the ESS standard recipe
  - No safety margin from JLAB recipe
- More advanced recipe!

Step	Amount
Bulk BCP	90+110 μm
600C annealing	10 hours
Final BCP	20 μm



# high-Q / high-G cavities in the world

## 300C baking @ IHEP

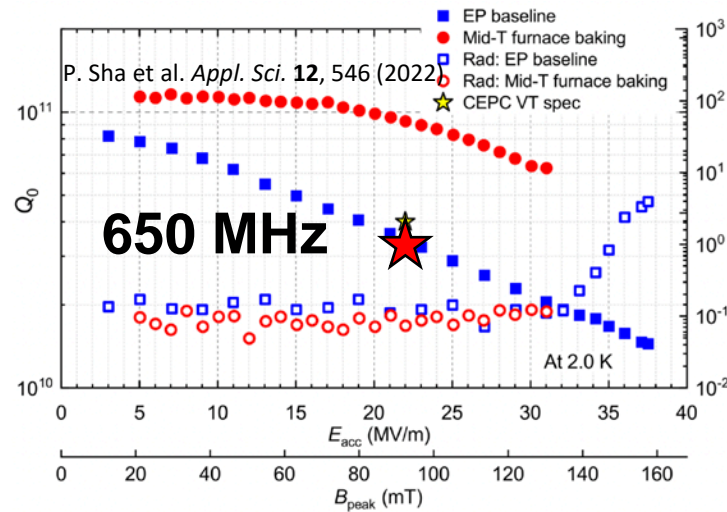

## 120C baking @ CEA-Saclay

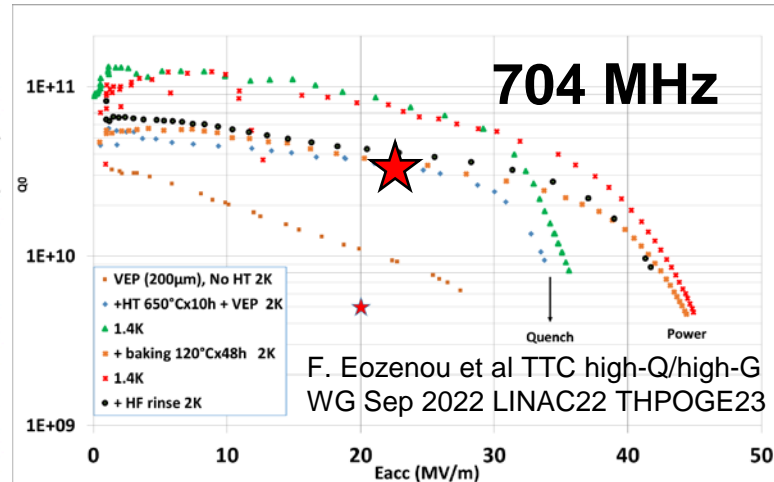

## 2N0 doping at 800C @ LCLSII

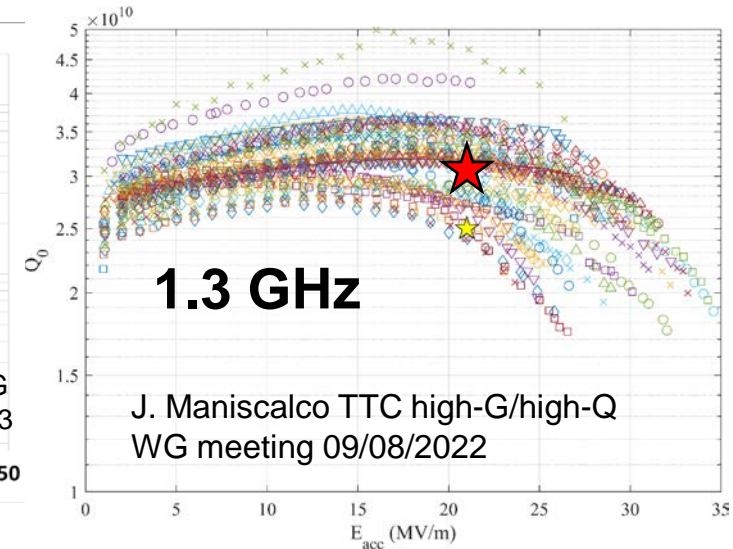

- 300C baking or N-doping seems like the best option for FCC/PERLE
- 120C or 2-step baking for higher gradient → ILC
- **Clean vacuum baking furnace** is key in this research domain

# 300C baking of DESY 1.3 GHz cavity in IJCLab

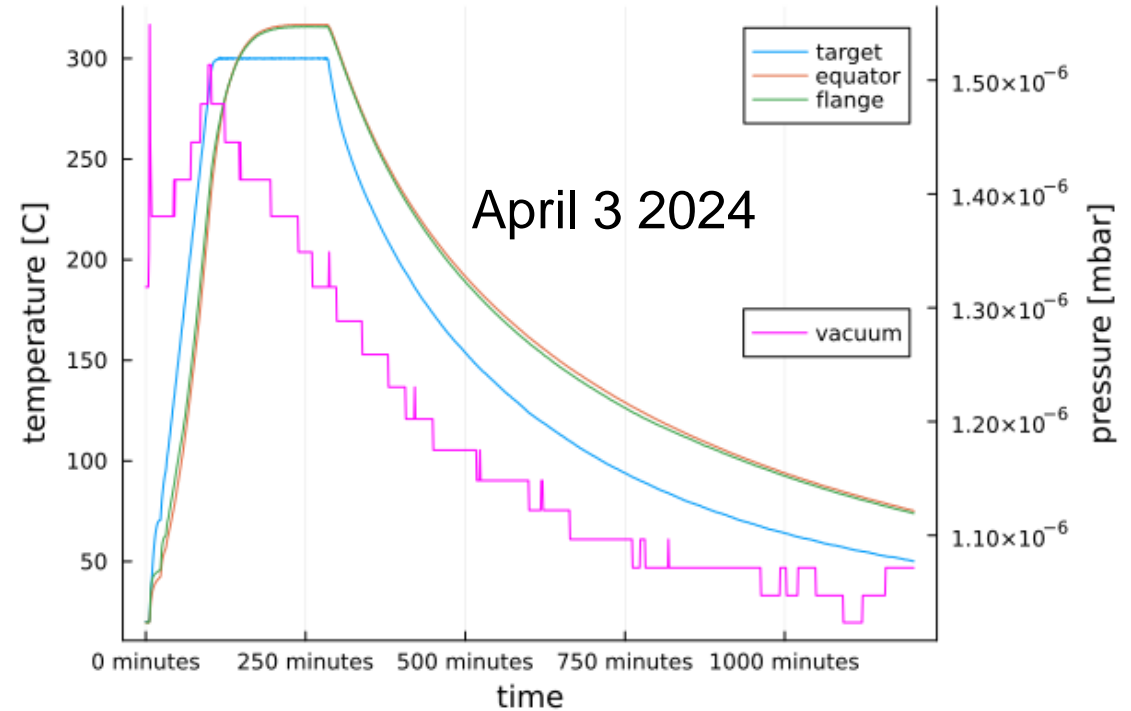
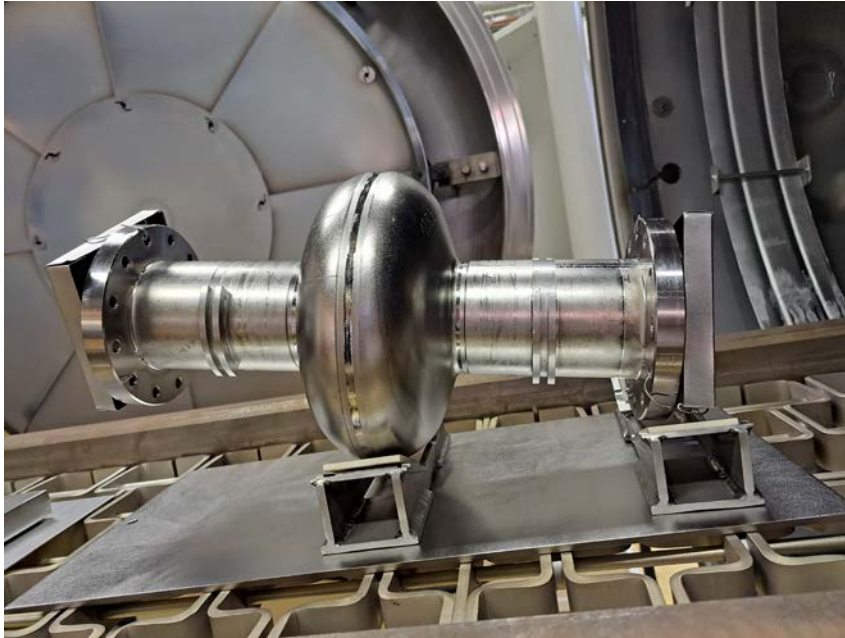

- Large volume → ultimate vacuum reach is not as good as KEK
- Offset between target (300C) and cavity (316C)
- No clean room around
  - Same as JLAB [bring cavities inside a plastic bag]
  - FNAL and KEK have clean room

**Very first  
mid-T bake  
in France**



# 1<sup>st</sup> test results

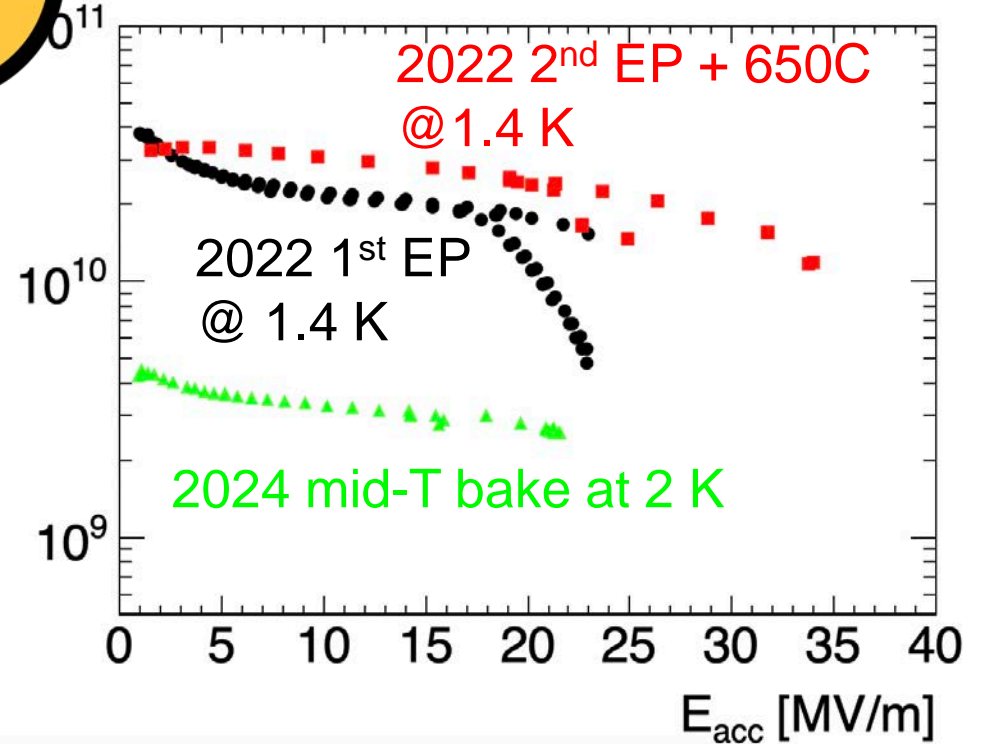
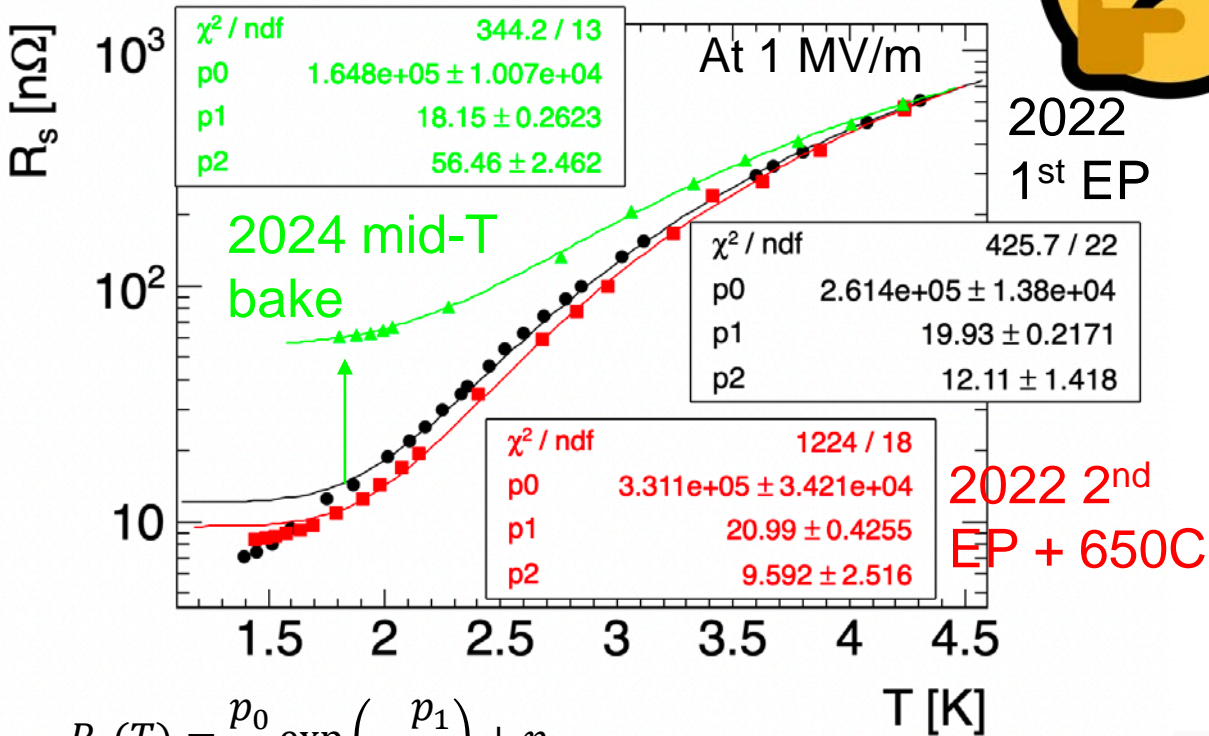

- The mid-T baked cavity showed significantly high residual resistance  $\Delta R_{res} > 46 \text{ n}\Omega$   
 → Is it due to contamination of furnace/cavity or magnetic field effect?



# Magnetic field sensitivity (1.3 GHz cavities)



## JLab

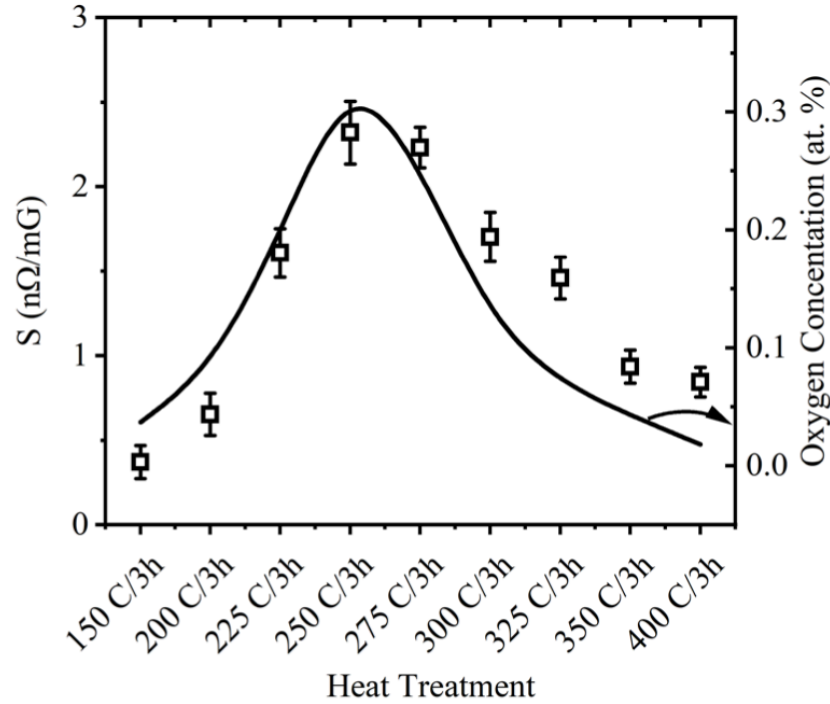

## KEK

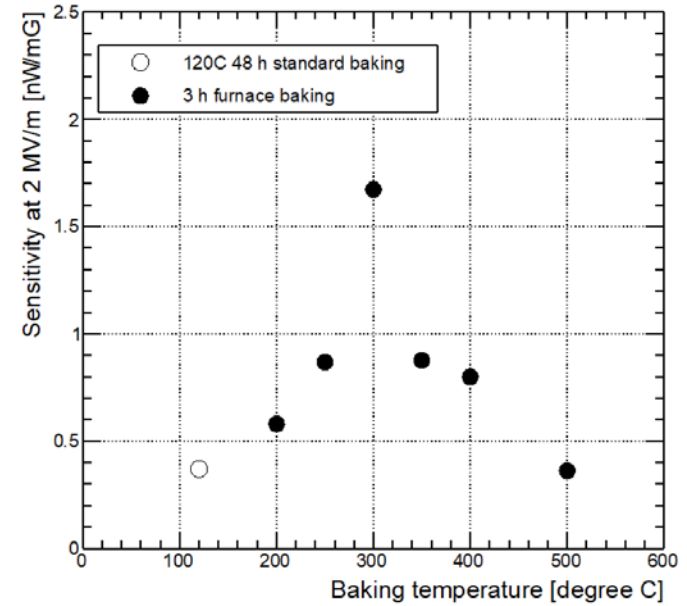

$$H_{ext} \sim 25 \text{ mG} = 2.5 \mu\text{T}$$

Not optimized for mid-T!

$$S \sim 2 \text{ n}\Omega/\text{mG}$$

$$\rightarrow \Delta R_{res} \sim S H_{ext} = 50 \text{ n}\Omega$$





## Surface resistance after improving the magnetic hygiene

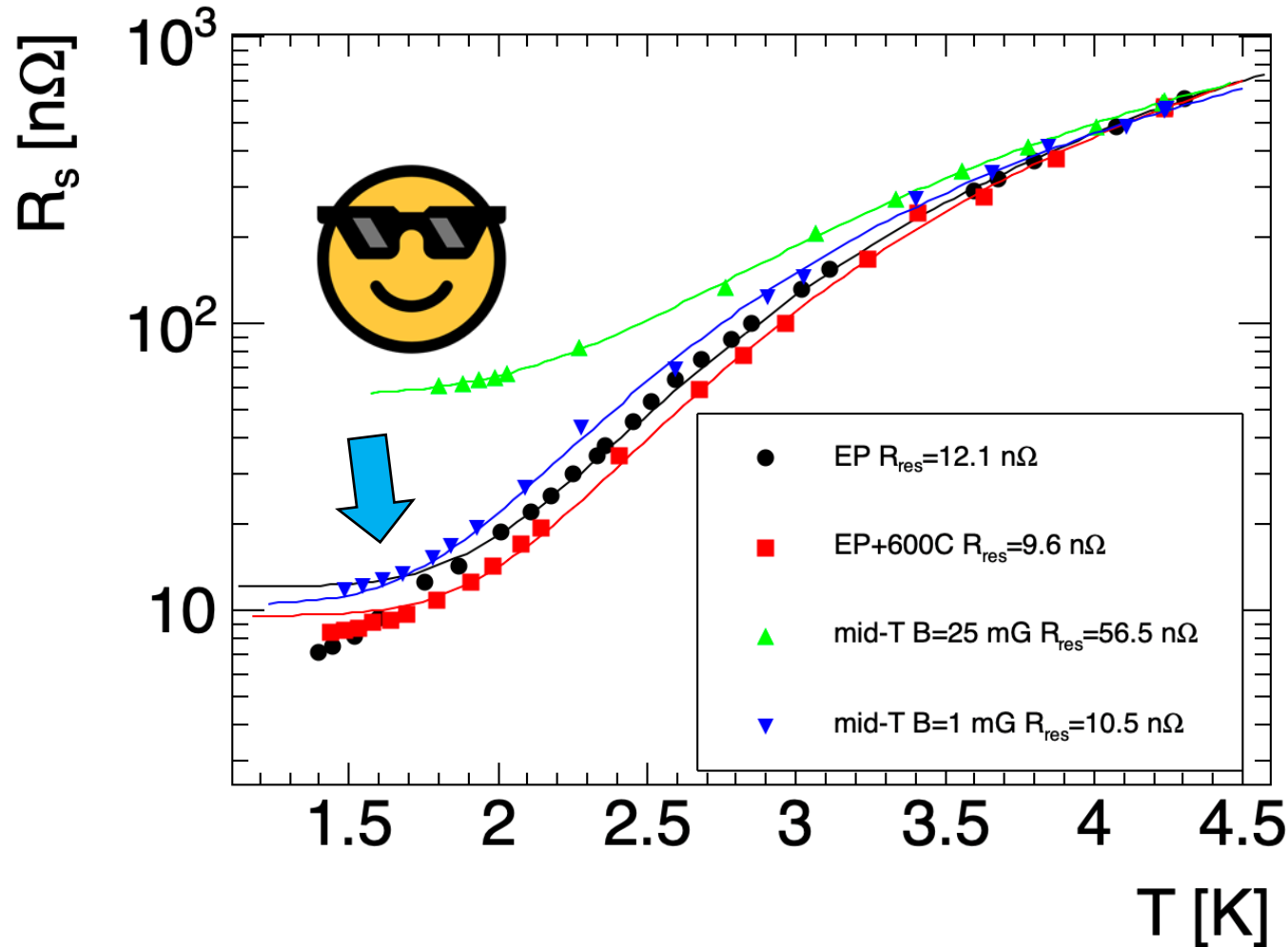

- The very high residual resistance of the last measurement after mid-T bake was due to the bad ambient magnetic field

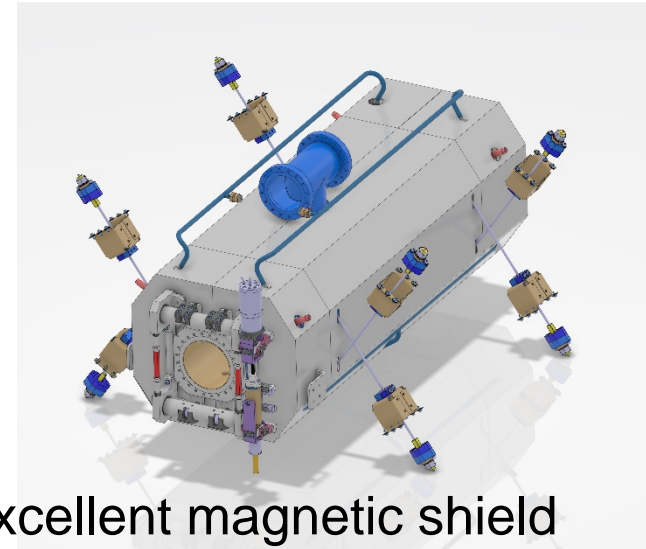
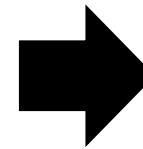

Excellent magnetic shield is under design



## Q vs E and Rs vs E

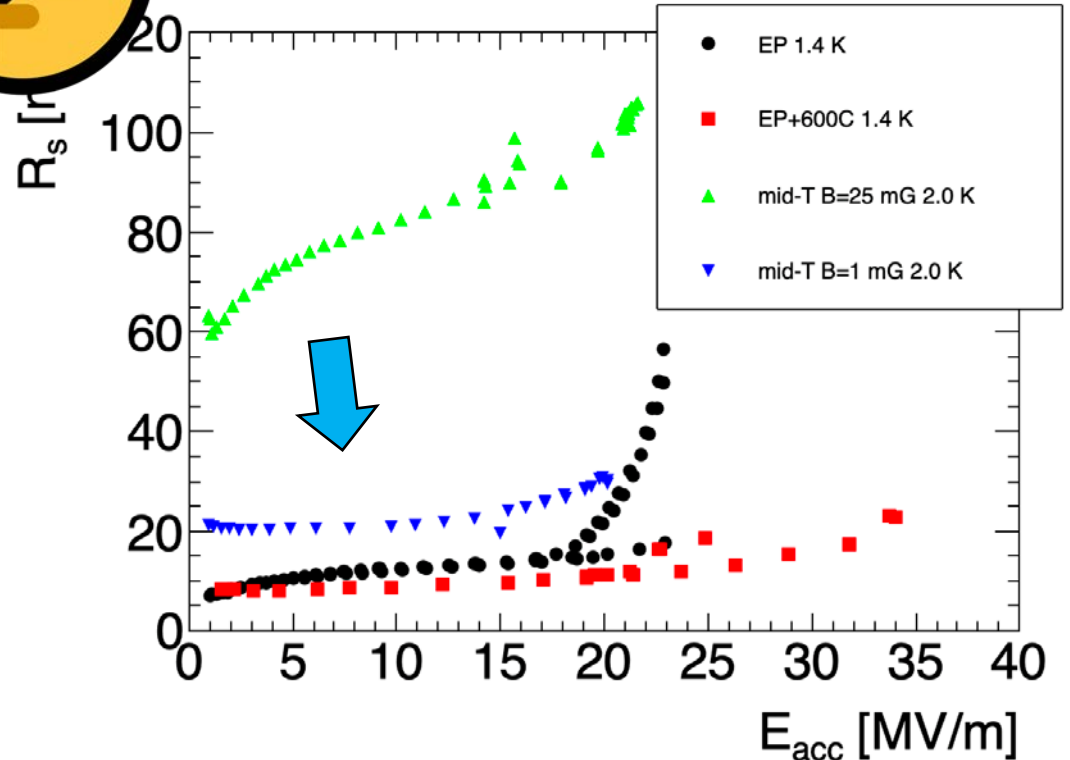
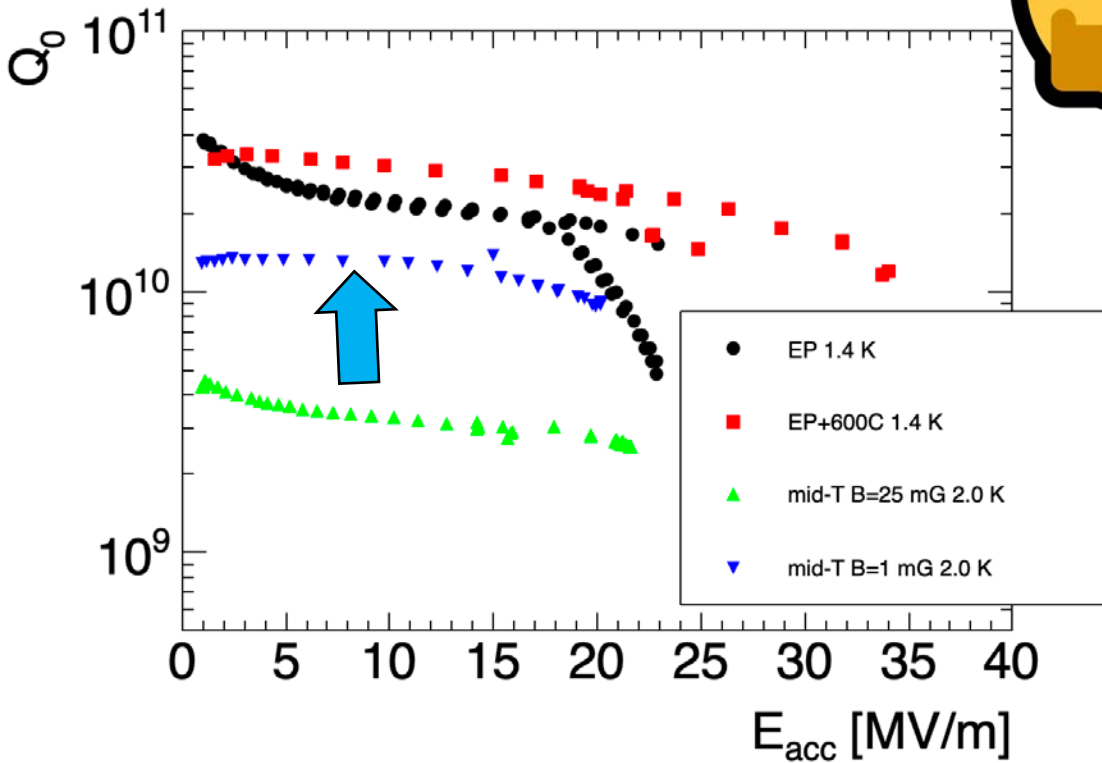

- 20 MV/m seems like a quench limit after the mid-T bake at 316C
- Maybe a small anti-Q-slope was observed
- Before mid-T bake data was taken at 1.4 K



## 2n cooling down: temperature sensors were OK (July 18 2024)

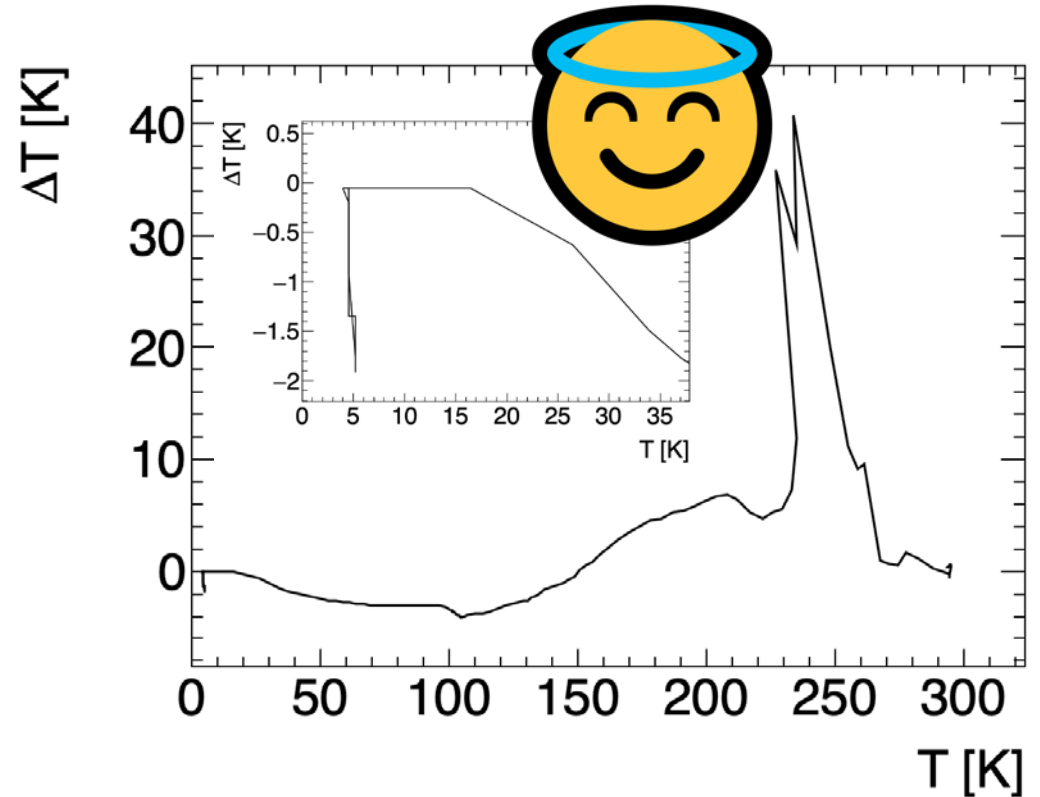
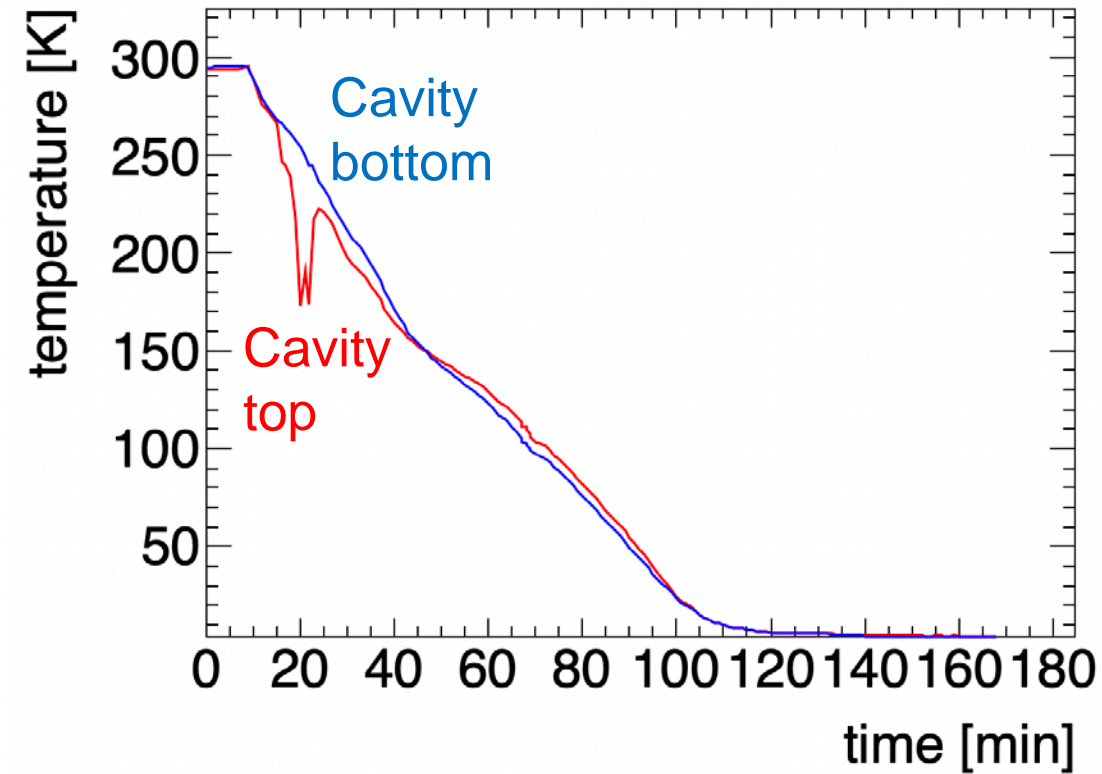

800C & 600C annealed 1.3 GHz cavity with  $\Delta T = 0$  at  $T_c = 9.25 K$   
→ No flux expulsion in the 2<sup>nd</sup> test results!



# Flux expulsion is mandatory for mid-T bake or N-doped cavities

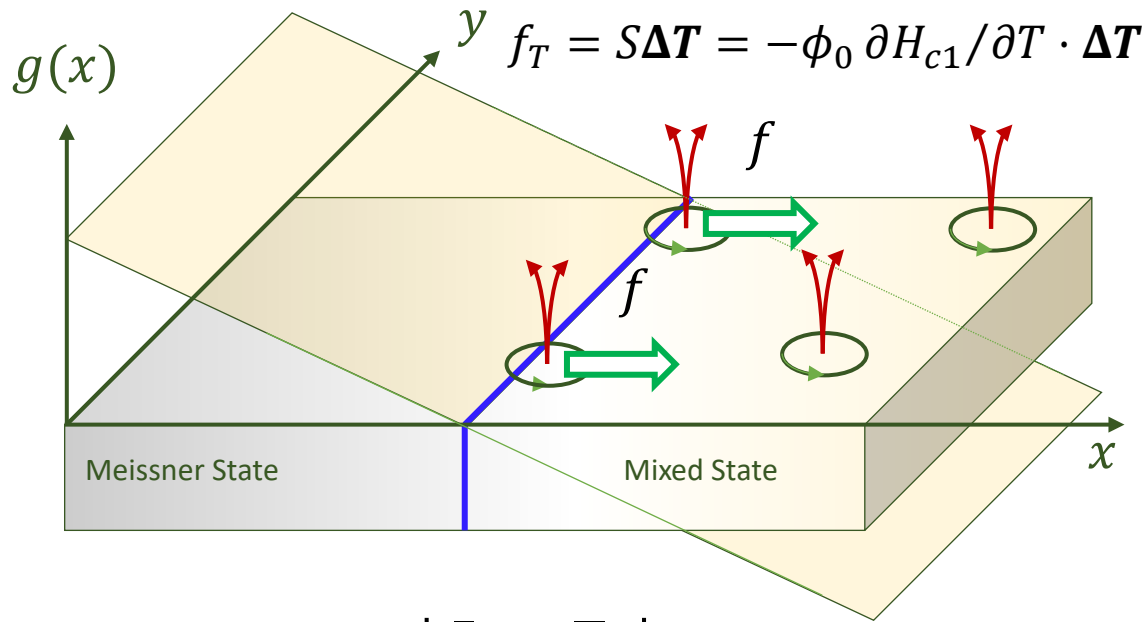

$$f_p = |\bar{J}_c \times n \bar{\Phi}_0| = J_c B$$

M. Checchin TTC topical workshop 2017

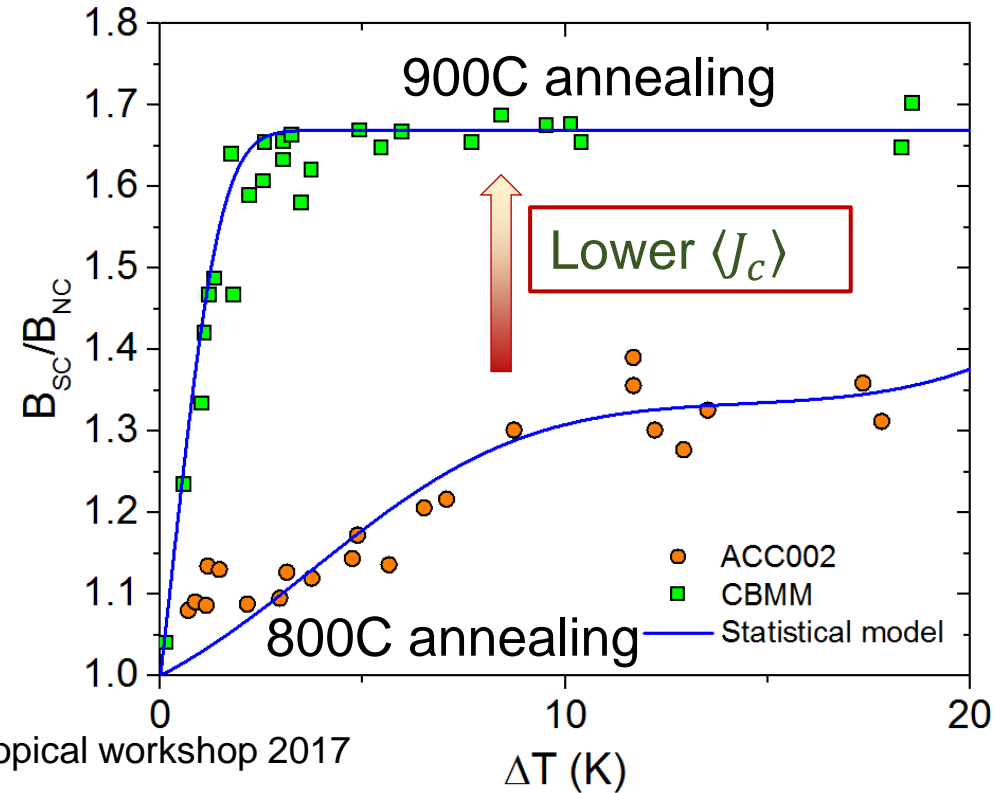

- Balance between thermodynamic force  $f_T$  and pinning force  $f_p$  in the mixed state
- Higher thermal gradient  $\rightarrow$  higher expulsion efficiency
  - $\rightarrow$  Cooling down with higher thermal gradient is a standard receipt in LCLS-II at SLAC



## 3<sup>rd</sup> test at KEK (1<sup>st</sup> week of October) being prepared

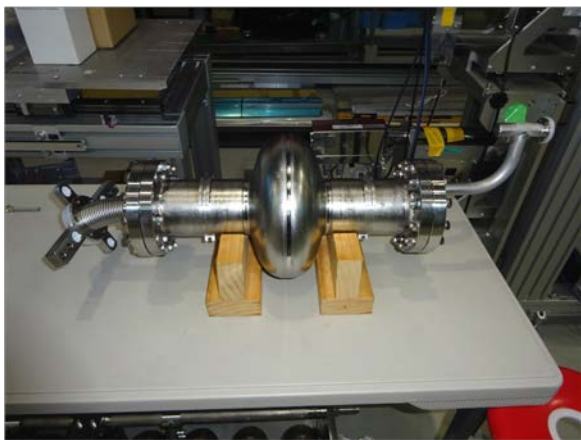
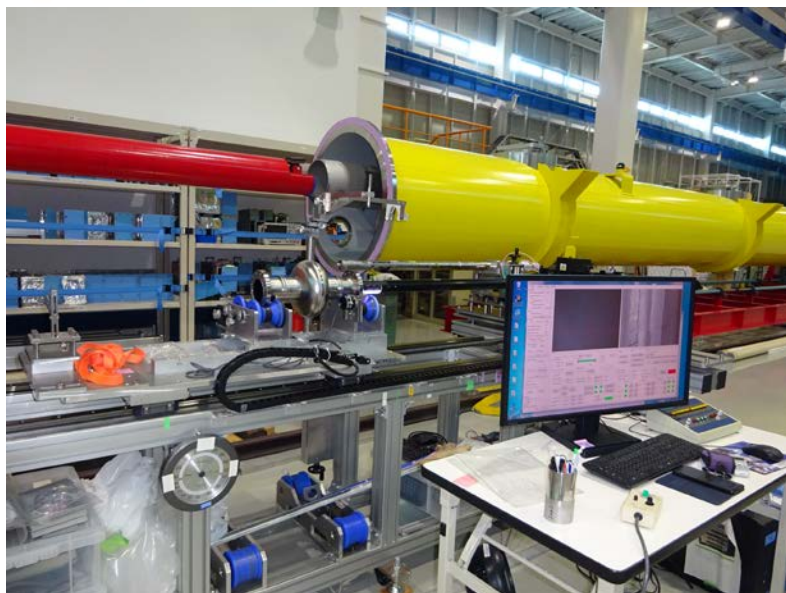

### Our results so far

- No perfect magnetic field
- No flux expulsion

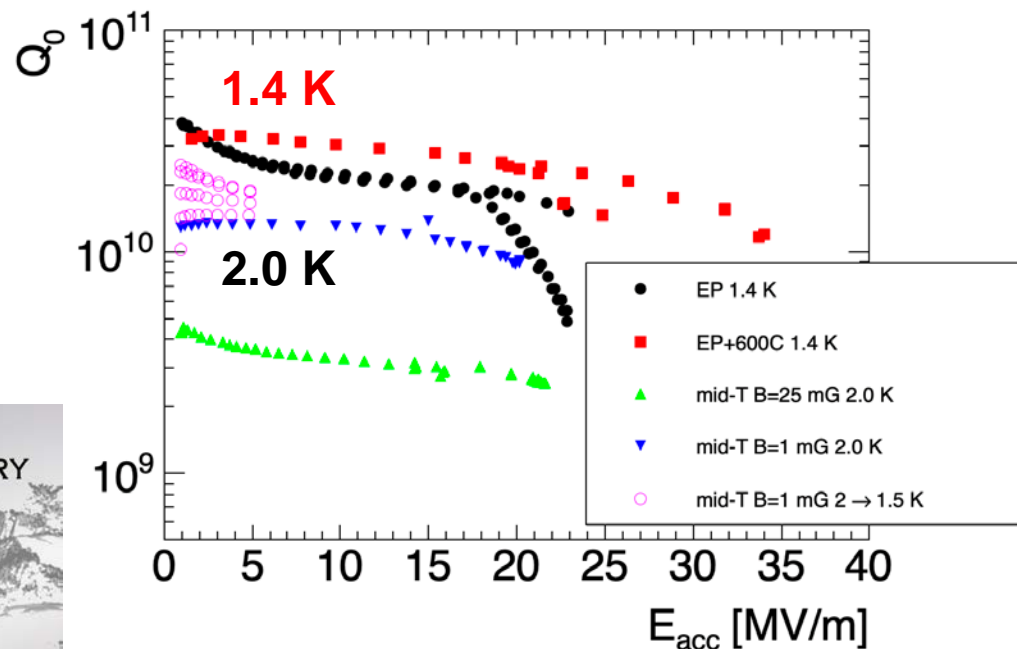

KEK have excellent reference data  
→ Cold test at KEK next week (FJPPN)



## Booster cavities: low gradient requirement: new proposal

$E_{acc} = 9.2 \text{ MV/m}$  & Single cell 800 MHz  $\rightarrow$  Nb<sub>3</sub>Sn/Nb at 4 K is realistic!

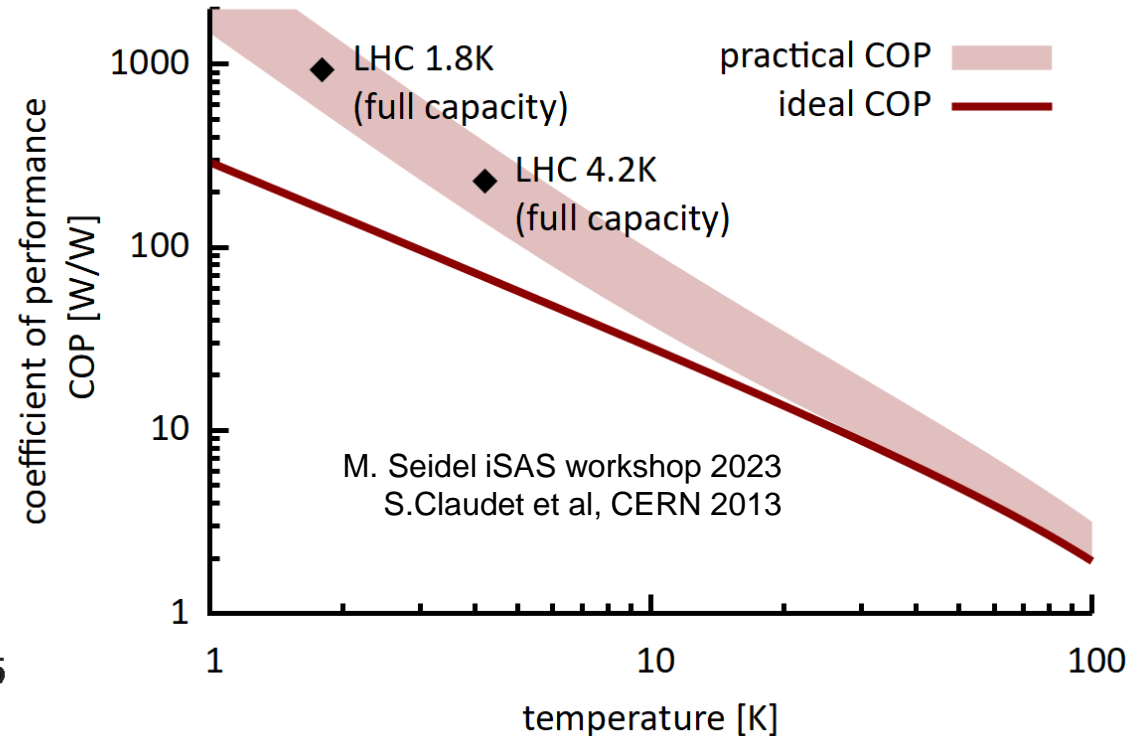
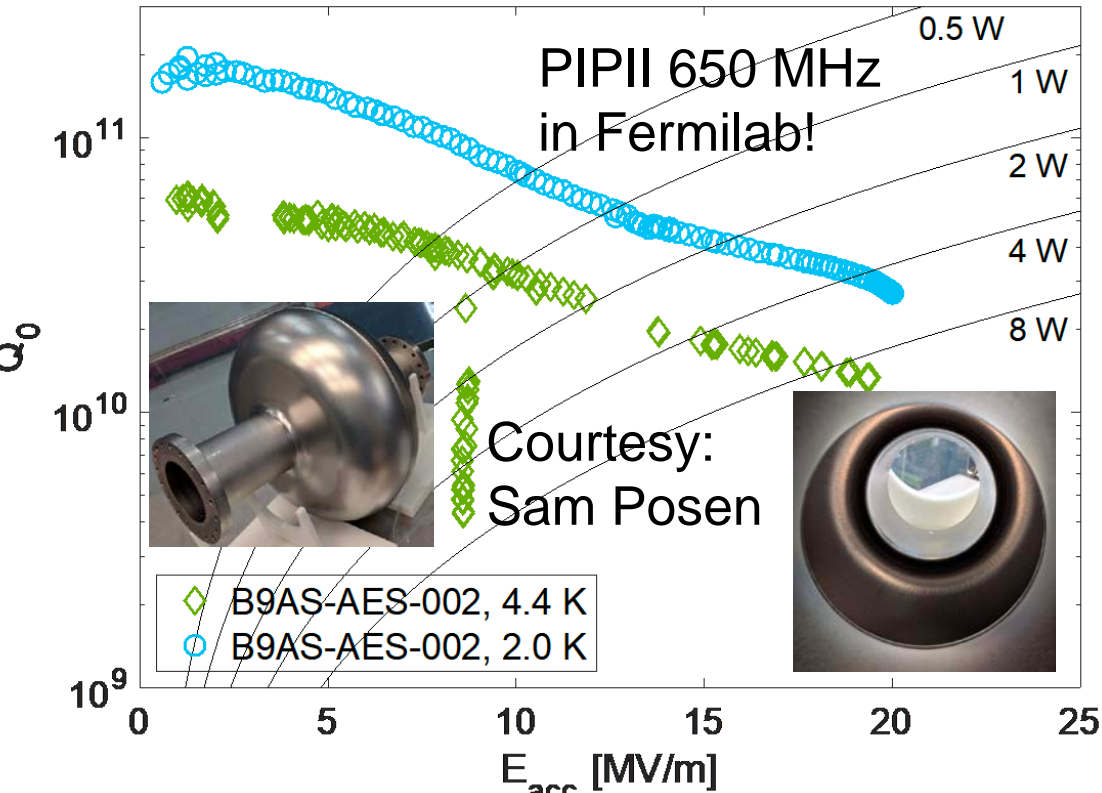

- Timeline: 4 years  $\rightarrow$  800 MHz single cell prototype for Nb<sub>3</sub>Sn test after mid-T bake
- Nb<sub>3</sub>Sn booster + mid-T bake ERF  $\rightarrow$  the most advanced SRF accelerator project!
- ~~Crycooler is probably too ambitious at this moment~~



# Conclusions

- **IJCLab has been a world-leading laboratory of SRF cavities for proton / heavy ion linear accelerators**
  - R&D of Spiral2, ESS, MYRRHA, PIP-II cavities are coming to the final phase
  - Contributions to collider projects has been in beam dynamics and nanobeams (ATF), RF couplers (Eu-XFEL), temperature sensors (LHC), etc
- **IJCLab is expanding R&D activities of SRF cavities towards future colliders**
  - Very ambitious specification (however not impossible according to the literature)
  - No sufficient R&D: time and money → international collaboration to complement it
- **Advanced heat treatment is the key R&D subject**
  - IJCLab is equipped with a clean vacuum furnace originally used for the ESS spoke cavity project
  - Mid-T baking for super high-Q
  - 1<sup>st</sup> mid-T baked results in 1.3 GHz cavity → studies on-going
- **Future prospects (end 2024 – beginning 2025)**
  - 3<sup>rd</sup> test at STF in KEK (October) with flux expulsion **next week**
  - Repairing JLAB 800 MHz prototype cavity (welding issue)
  - Procurement of Nb materials and cavities
  - Magnetic shield in the CM is being designed
- **Collaborations**
  - Collaboration with INFN-LASA / CEA Saclay via iSAS
  - ERL collaboration with KEK via FJPL
  - FCC: collaboration with CERN/FNAL
  - PERLE: collaboration with CERN/JLAB
  - Potential collaboration with IHEP (?)



# Acknowledgement: SRF cavity teams outside PERLE

Mohammed Fouaidy, Nicolas Gandolfo, David Longuevergne,  
Mael Vannson, Lê My Vogt

CNRS/IN2P3/IJCLab Université Paris-Saclay

Matthieu Baudrier, Enrico Cenni, Fabien Eozénou,  
Grégoire Jullien, Luc Maurice

CEA/IRFU/DACM Université Paris-Saclay

backup



# Introduction : Instances around SUPRAtech

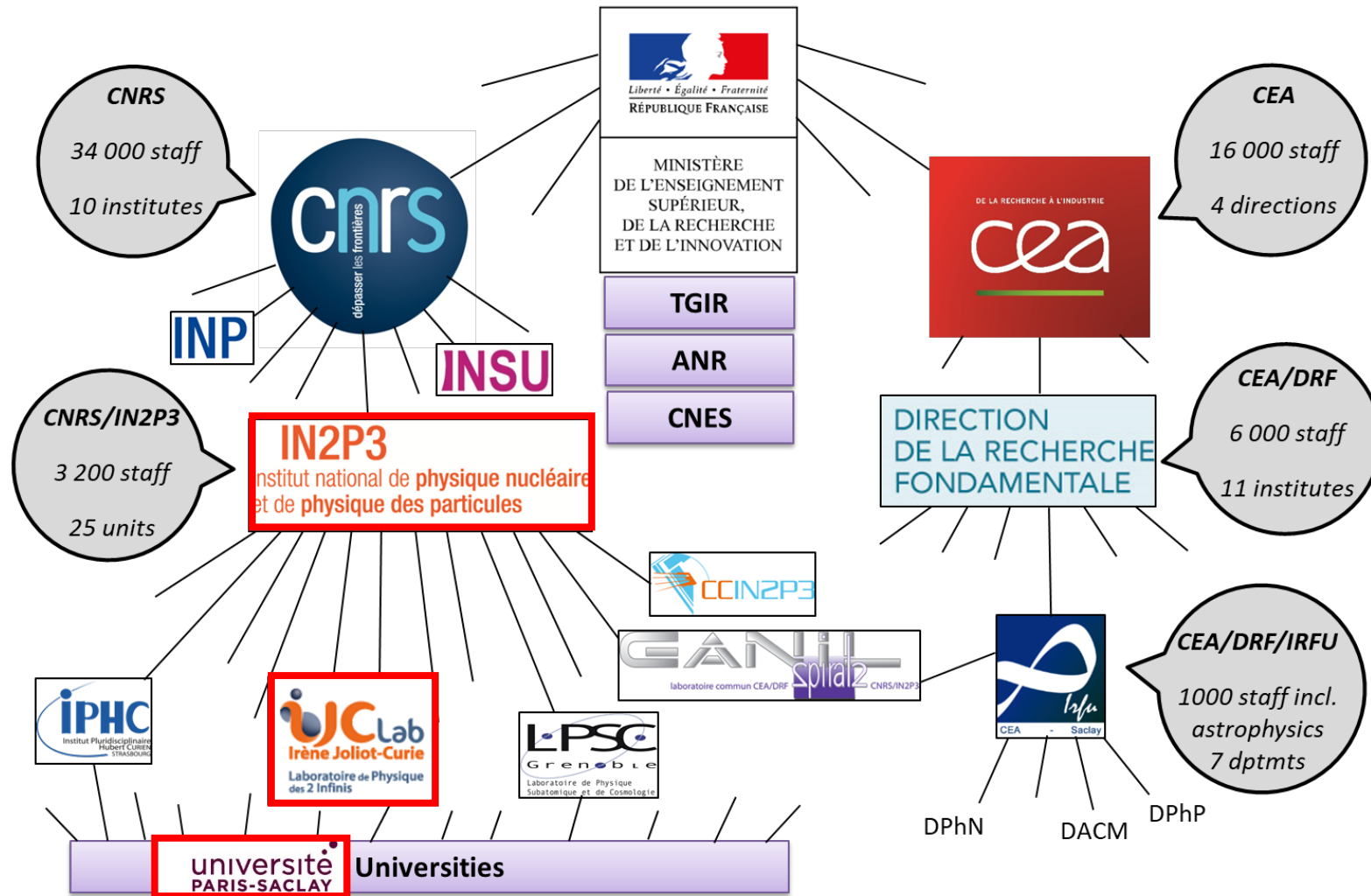

Credits :  
J.L. Biarrotte



# Introduction : History summary and series production

Prototyping Phase

Series production

R&D



**Spiral2** : Integration and test of 7 cryomodules



**ESS** : - preparation & testing of cavities, couplers and tuners  
- Integration of 14 cryomodules



**LHC** : Calibration of all Cernox thermal sensors (> 6000 units)



**EU-XFEL** : Preparation and power testing of 800 couplers

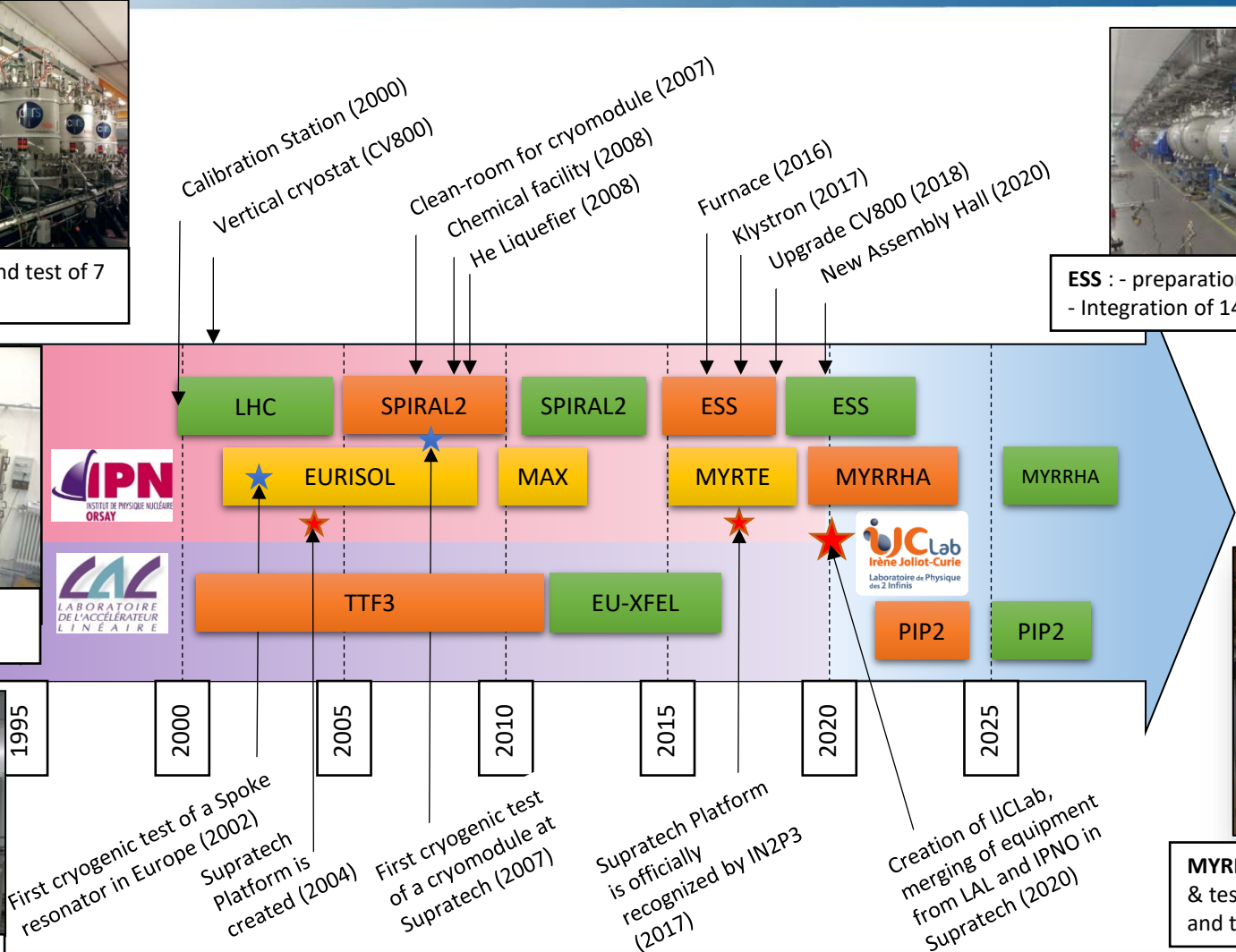

Calibration Station (2000)  
 Vertical cryostat (CV800)  
 Clean-room for cryomodule (2007)  
 Chemical facility (2008)  
 He Liquefier (2008)  
 Furnace (2016)  
 Klystron (2017)  
 Upgrade CV800 (2018)  
 New Assembly Hall (2020)

1995  
 2000  
 2005  
 2010  
 2015  
 2020  
 2025

First cryogenic test of a Spoke resonator in Europe (2002)  
 Supratech Platform is created (2004)  
 First cryogenic test of a cryomodule at Supratech (2007)  
 Supratech Platform is officially recognized by IN2P3 (2017)  
 Creation of IJCLab, merging of equipment from LAL and IPNO in Supratech (2020)

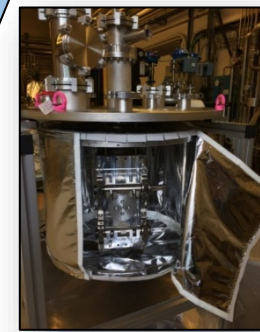

**MYRRHA** : - preparation & testing of 60 couplers and tuners

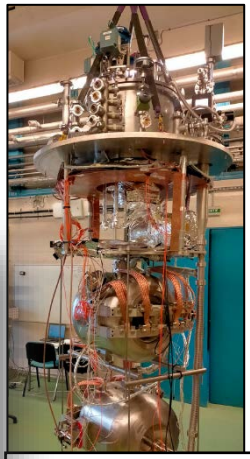

**PIP-II** : Testing of 33 Spoke cavities

## For FCC/PERLE

Duty cycle  
=100%



Extremely high-Q at relatively high gradient in large cavities (800 MHz)

## For ILC250

Duty cycle  
<1%

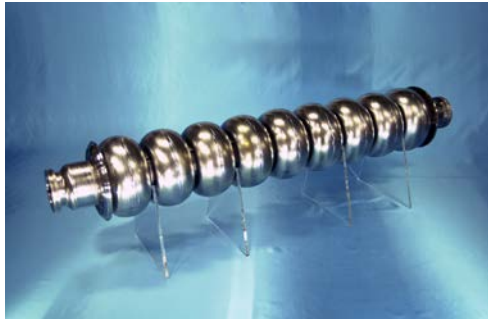

Extremely high gradient with relatively high-Q in a large # of cavities (~8000)

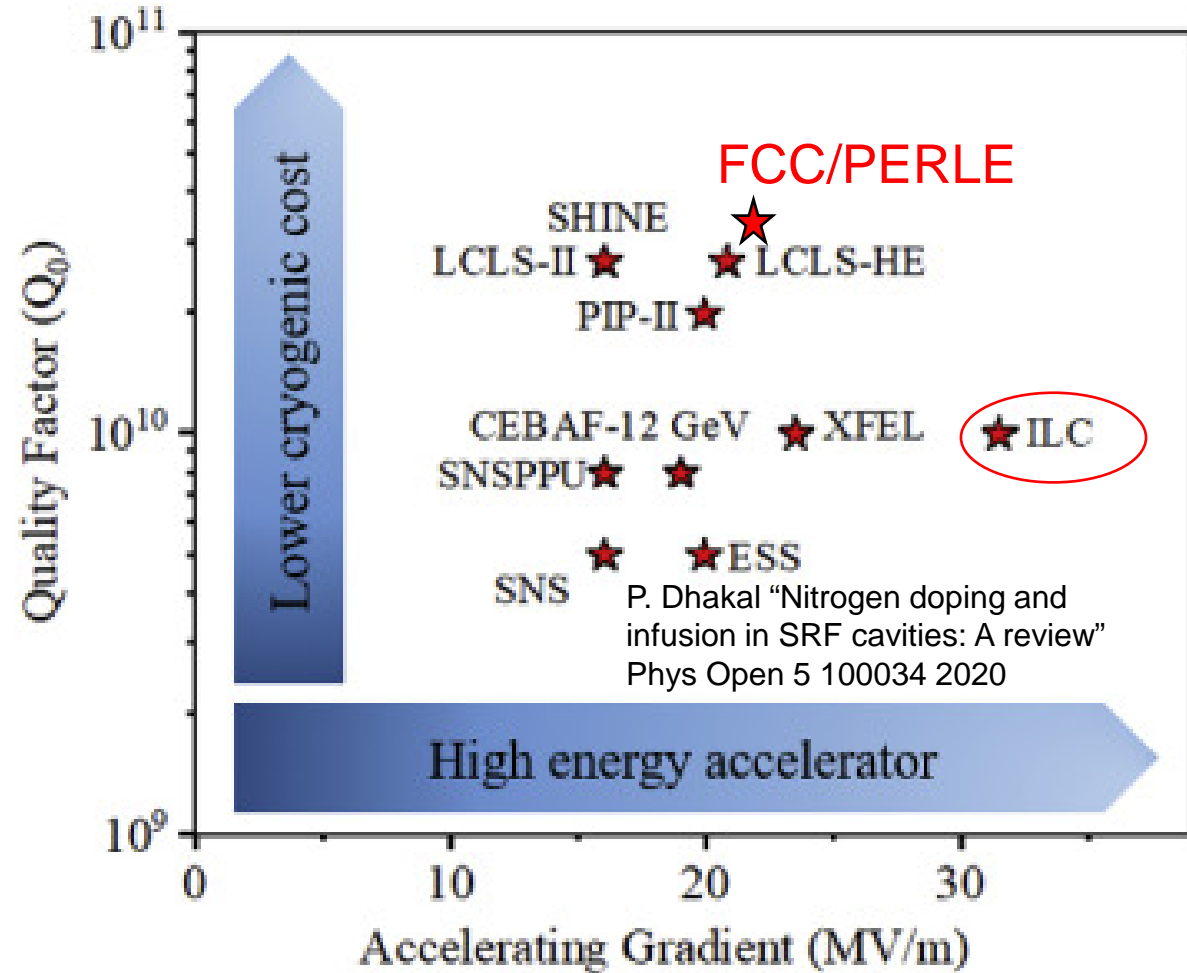



# List of the advanced recipes

## xNy doping

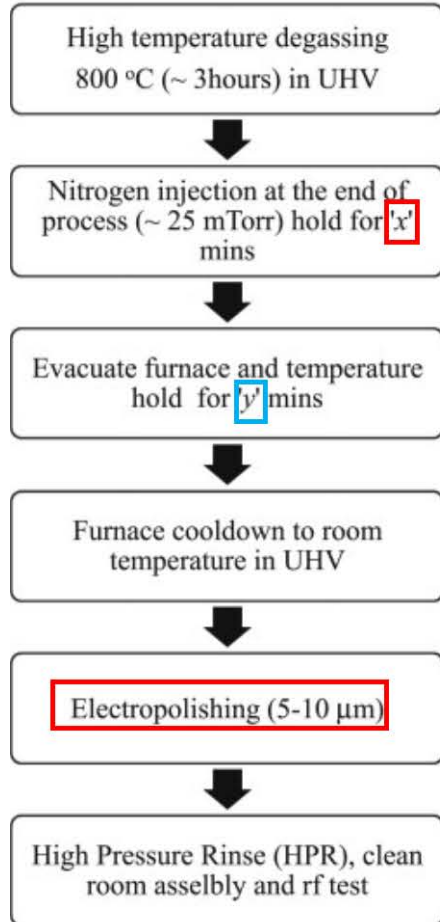

## N-infusion

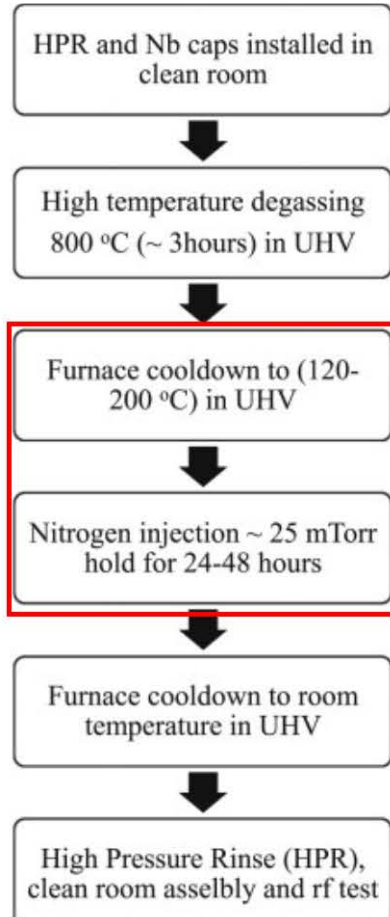

## 2-step baking (1.3 GHz)

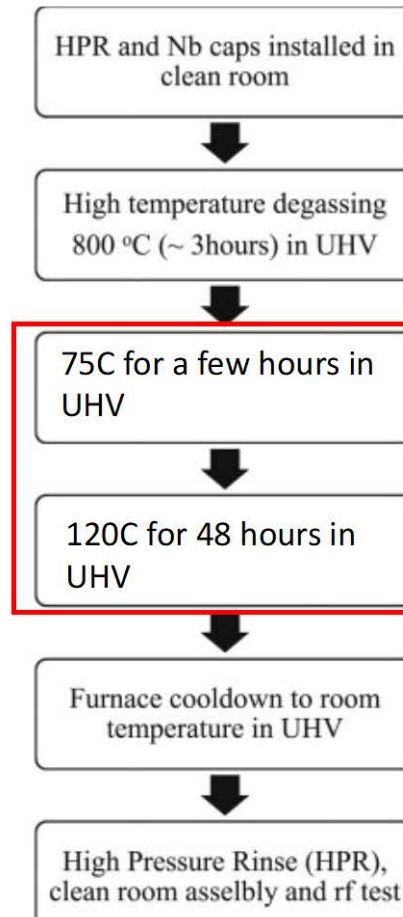

## Mid-T baking

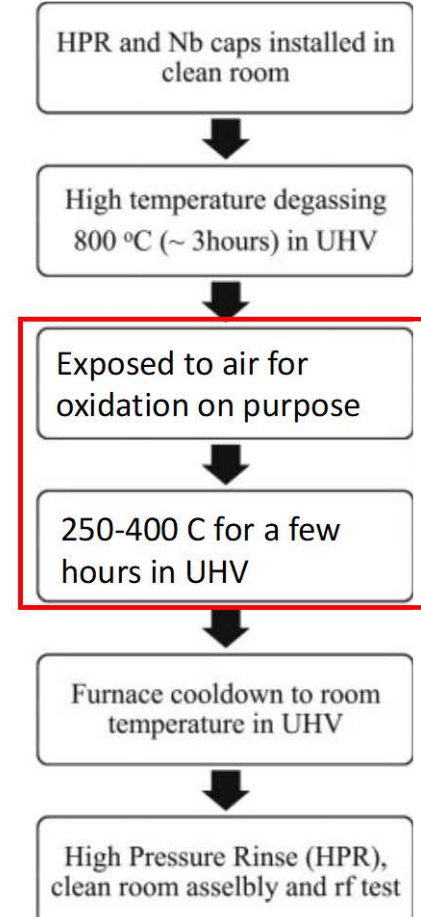



## Compare to JLAB result at 2 K: 25 mG case

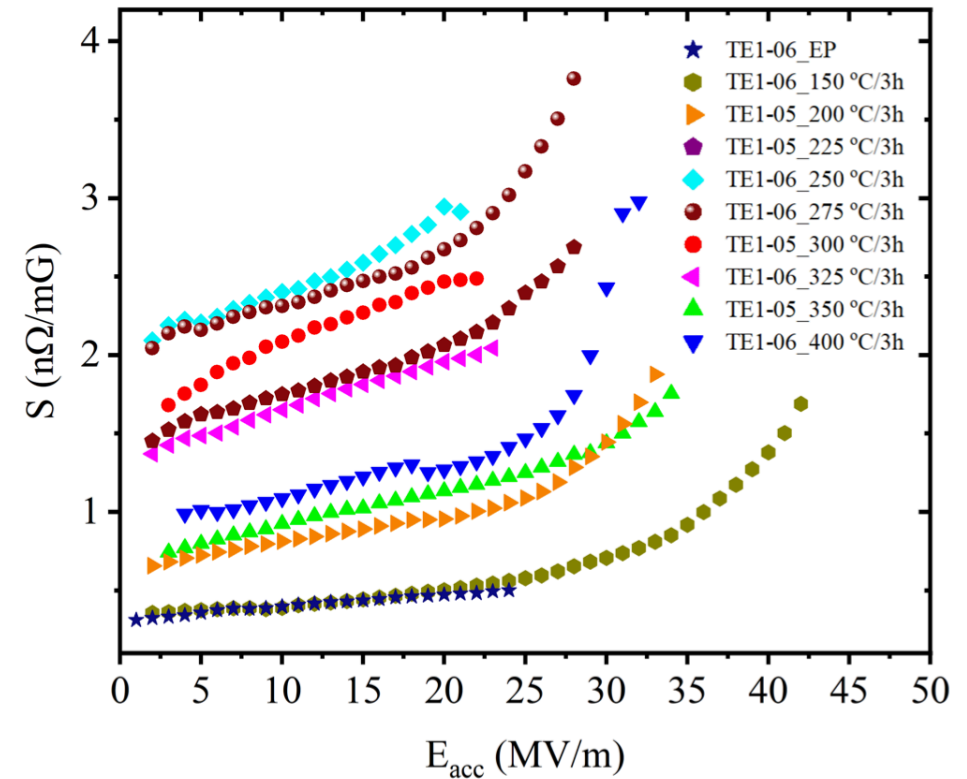
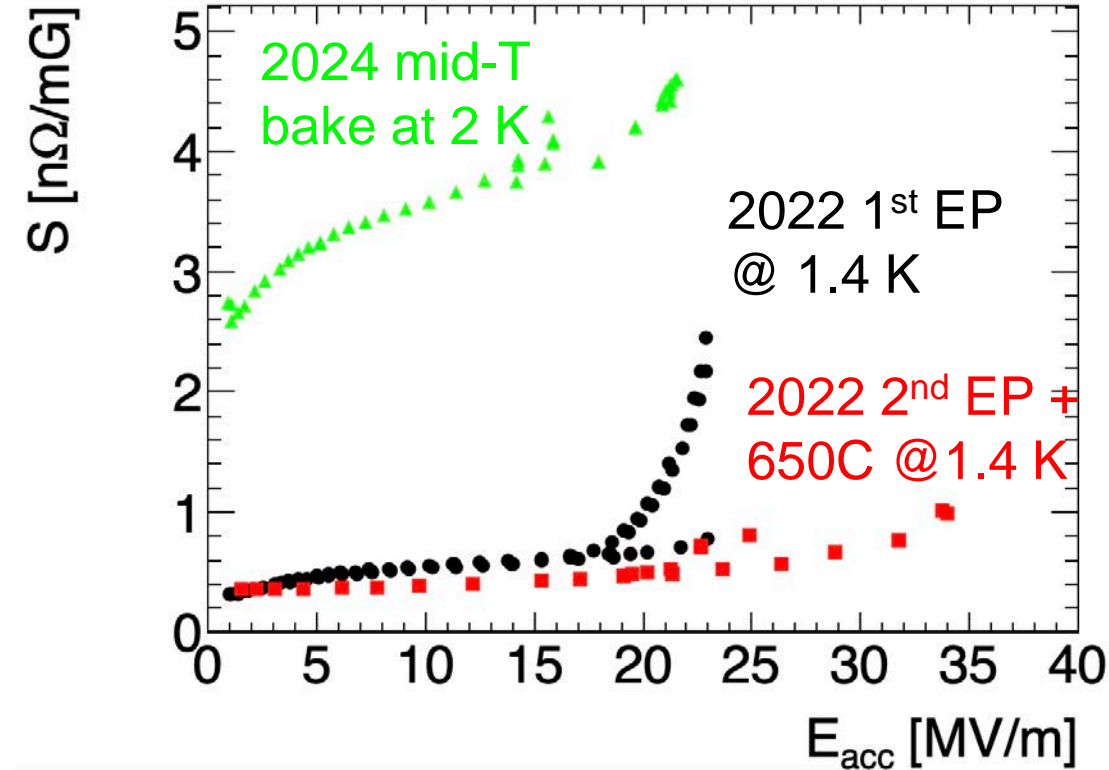

- We could explain the degradation of Q due to non-optimized magnetic shield and high sensitivity to trapped flux in mid-T baked cavities  
→ Improving magnetic shield and installing magnetic field at CEA!



## Clean vacuum furnace at IJCLab: same as the one in ZANON

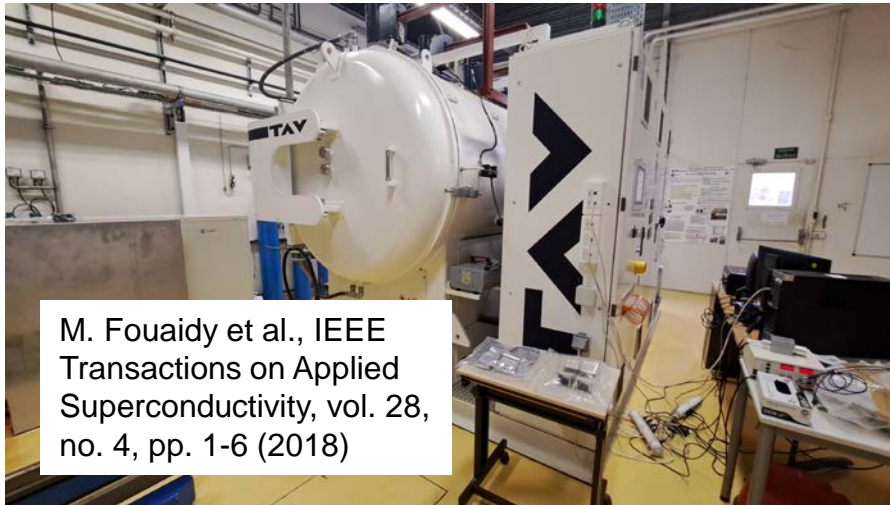

M. Fouaidy et al., IEEE Transactions on Applied Superconductivity, vol. 28, no. 4, pp. 1-6 (2018)



- Vacuum furnace originally used for 600C annealing of ESS spoke cavities
- A cryogenic pump, pure Ar for purging etc
- Never used for advanced heat treatment (mid-T bake)
- Annealing at 800C with samples to see contaminations