

Production and physics of top quark at the Large Hadron Collider, Prospects at HL-LHC

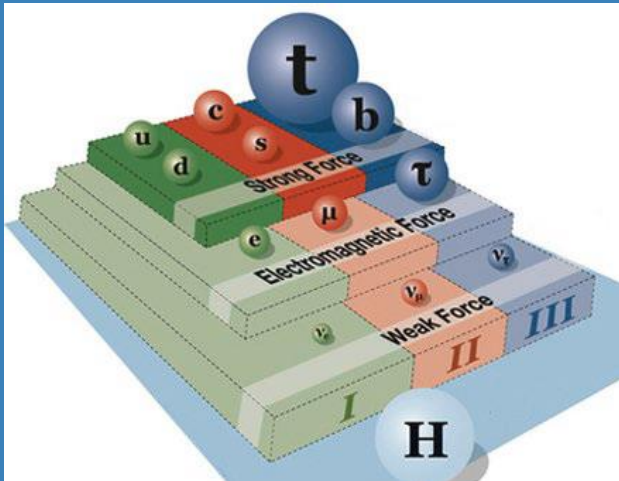

María José Costa (IFIC, CSIC-UV)
Les Rencontres de Noirmoutier, 4 June 2026

Top quark pair production

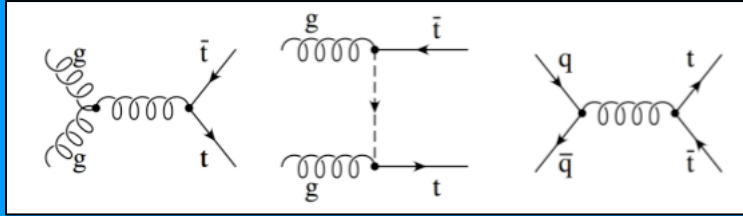
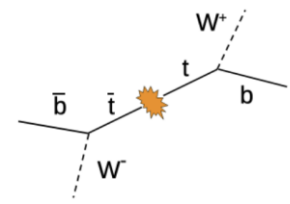

Very high production rate at the LHC:
 800 pb cross section \rightarrow $> 100M$ $t\bar{t}$ pairs (about 15 pairs/s at 13 TeV).
 Test state-of-the-art QCD predictions, extraction of fundamental parameters, potential for new physics contributions.

Covered in this talk:

- Highlights of inclusive and differential cross-section measurements
- Production at threshold
- Determination of parameters: top mass, top-Higgs Yukawa, V_{cb} CKM matrix element

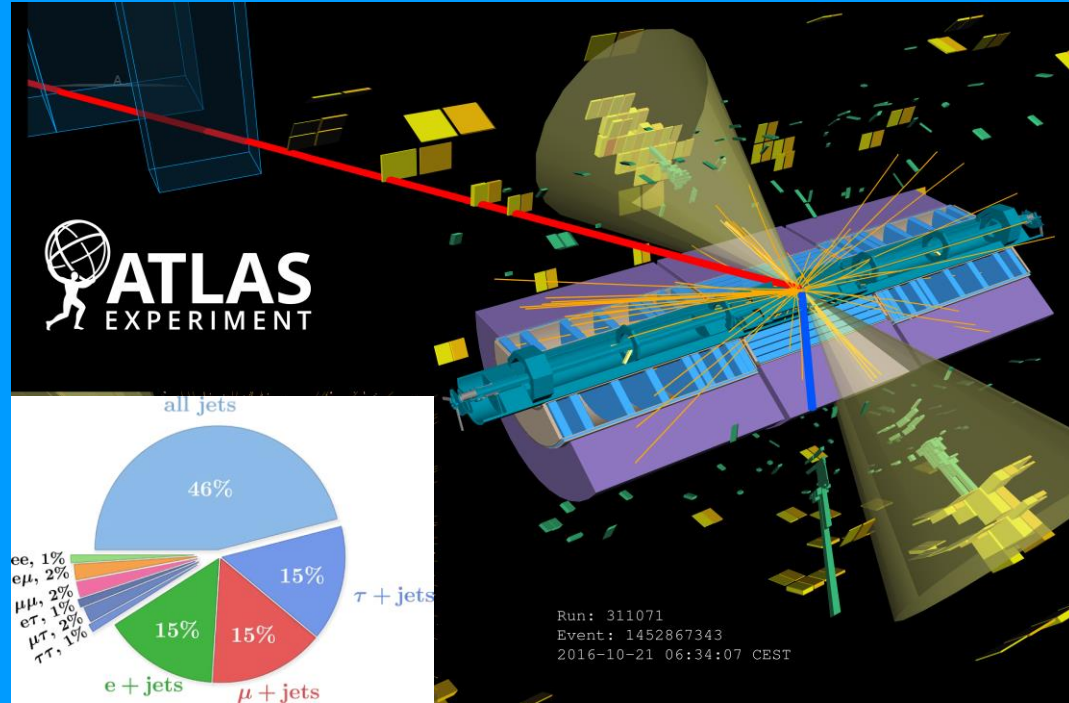

Top quark pair production: Cross section

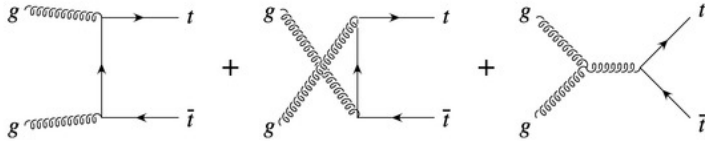

- Dominant production at the LHC: gluon fusion
- Test of perturbative QCD predictions:
 - State of the art: NNLO+NNLL QCD
- Extraction of top-quark pole mass (theoretically cleanest approach)
- Measurements in agreement with theory predictions
- Experimental precision challenges theory
- Two examples as highlight:
 - **ATLAS** (not included in the plot): Using the cleanest channel ($e\mu$ final state) with full Run-2 dataset (140 fb⁻¹) at $\sqrt{s}=13$ TeV: **Most precise measurement of inclusive cross section (1.3%)!** Higher statistics allows for differential measurements [[arXiv:2509.15066](https://arxiv.org/abs/2509.15066), submitted to EPJC]
 - **CMS**: Using a small (302 pb⁻¹), but low pile-up dataset ($\langle\mu\rangle < 2$) at $\sqrt{s}=5.02$ TeV [[JHEP 04 \(2025\) 099](https://arxiv.org/abs/2504.099)]

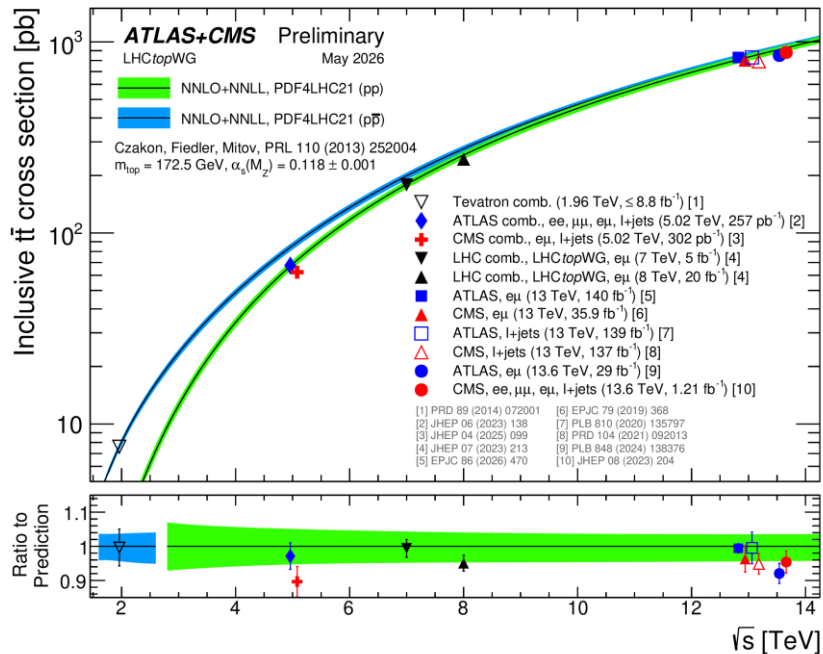

Top quark pair production – Cross section

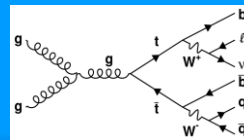

- Data collected in autumn 2017, in dedicated runs with low-energy and low-intensity conditions: $\sqrt{s} = 5.02$ TeV, 302 pb^{-1} . Profits from low pile-up but low statistics power, $O(3000)$ events.
- Measurement in the lepton+jets channel, combined with previous one in dilepton $e\mu$ channel.
- Events are classified based on lepton flavour, the number of all reconstructed jets and of b-tagged jets (90% purity in 3j2b and 4j2b regions).
- MVA used in the 3j1b region to enhance the separation between the signal and backgrounds.
- Profiled maximum likelihood fit to the MVA score and $\Delta R_{\text{med}}(j, j')$ distributions.

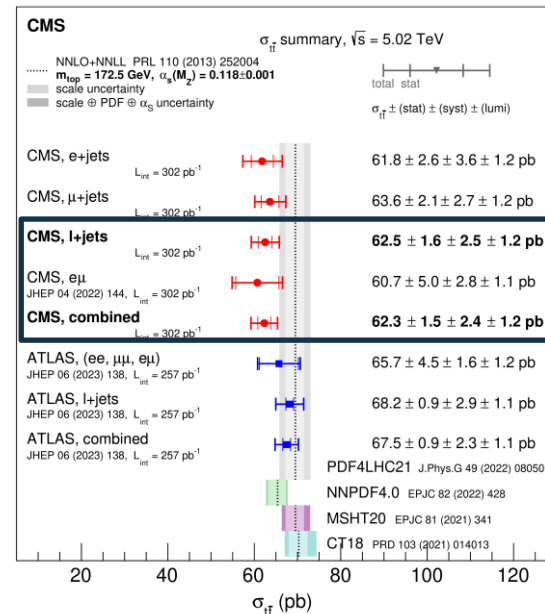

- ~5% relative overall uncertainty
- Dominant systematics uncertainties: luminosity, signal modelling and b-tagging efficiency.

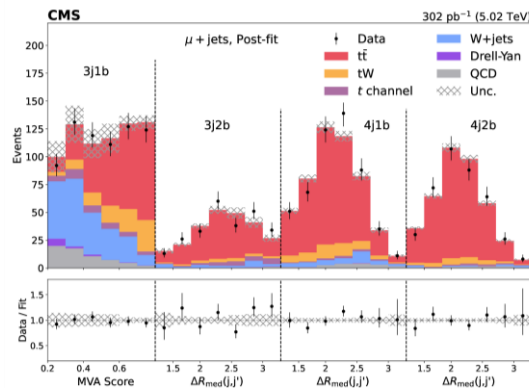
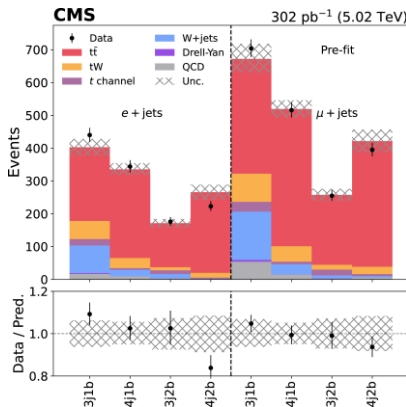

Top quark pair production – Cross section

Cut-and-count in regions of 1 and 2 b-tagged jets to measure simultaneously the cross-section and jet reconstruction and tagging efficiency (ϵ_b):

- First use of Powheg MiNNLO+PY8 to model signal (better modelling of lepton p_T)
- In-situ measurement of lepton isolation efficiency
- 1D and 2D differential cross sections as a function of lepton kinematics (limited by statistical uncertainties, also signal and tW / $t\bar{t}$ interference)

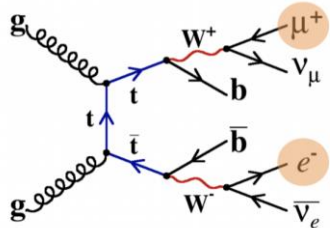

$$N_1 = L\sigma_{t\bar{t}} \epsilon_{e\mu} 2\epsilon_b (1 - C_b \epsilon_b) + N_1^{\text{bkg}},$$

$$N_2 = L\sigma_{t\bar{t}} \epsilon_{e\mu} C_b \epsilon_b^2 + N_2^{\text{bkg}},$$

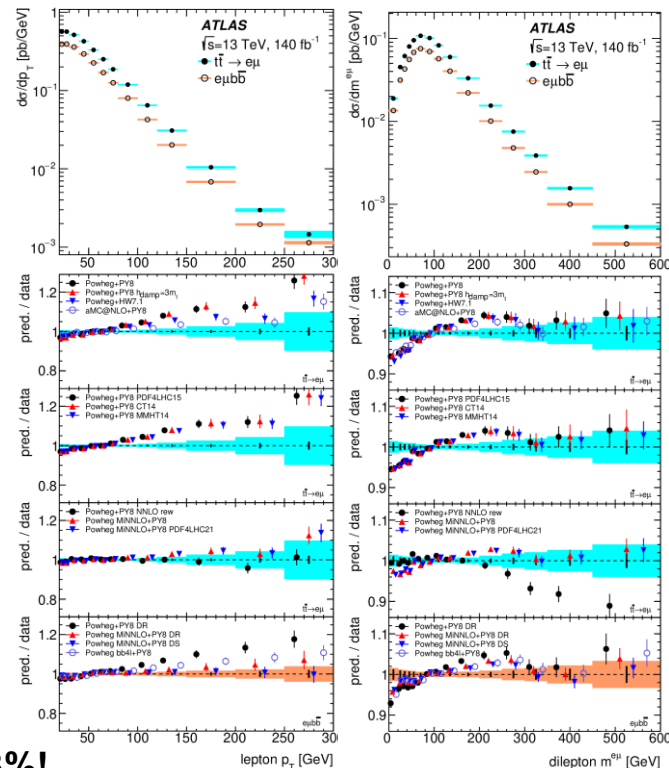
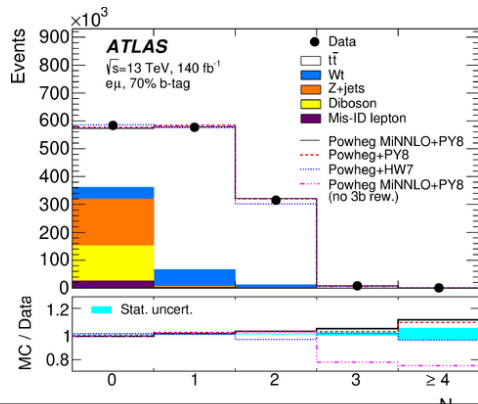

$$\sigma_{t\bar{t}} = 829.3 \pm 1.3 \text{ (stat)} \pm 8.0 \text{ (syst)} \pm 7.3 \text{ (lumi)} \pm 1.9 \text{ (beam) pb, } \mathbf{1.3\%}$$

$$m_t^{\text{pole}} = 172.8^{+1.5}_{-1.7} \text{ GeV}$$

Dominant uncertainty on measured cross section: luminosity, signal modelling
Top mass dominated by theory uncertainties.

The state-of-the art generators Powheg MiNNLO and Powheg bb4l describe data better than Powheg hvq (standard use so far)
Clear excess in the threshold region.

Top quark pair production – Threshold

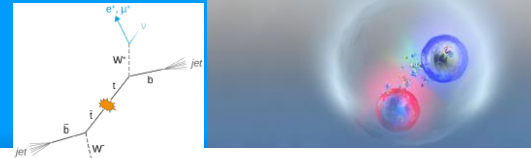

- At the production threshold ($m_{t\bar{t}} \approx 2 m_{\text{top}} = 345 \text{ GeV}$): top pairs with small relative velocities described by NRQCD (tops can exchange gluons before decaying individually)
- Quasi-bound state expected to manifest near the top production threshold as a spin singlet
- Measurements in the dilepton channel exploit spin observables and $t\bar{t}$ invariant mass

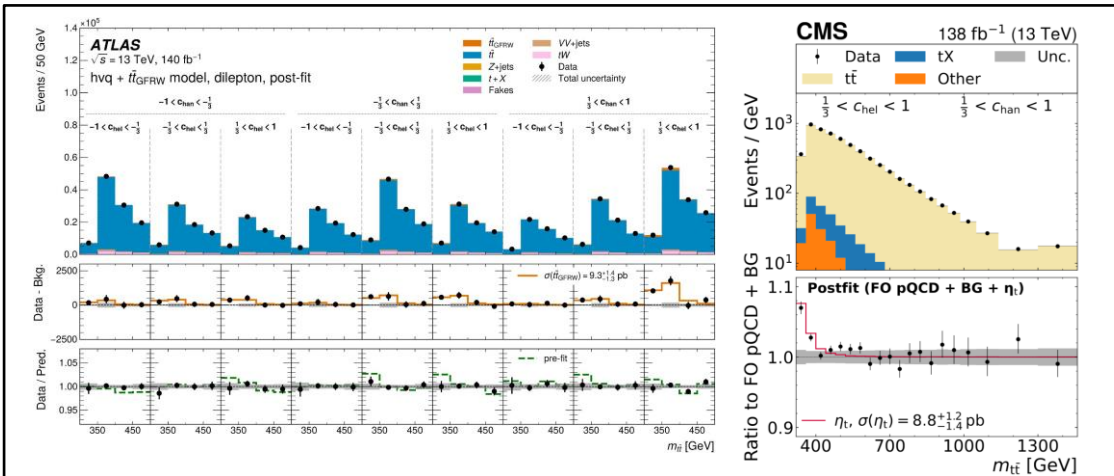
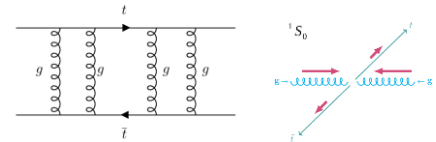

Effect not included in current pQCD models at (N)NLO, **assumed to be impossible to detect at the LHC!**

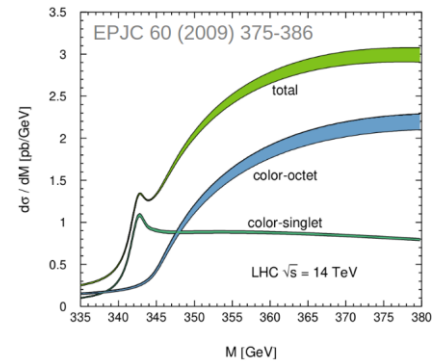

$\sigma_{\text{NR-QCD}} = 6.43 \text{ pb}$ (PRD 104 (2021) 034023)
 $\sigma_{\text{NR-QCD}} = 4.6 \pm 1.1 \text{ pb}$ (NLO+NLL NRQCD, 340-350 GeV) (arXiv:2604.09485)

[ROPP 89 \(2026\) 057801](#)
[ROPP 88 \(2025\) 087801](#)



$\sigma(t\bar{t}_{\text{GFRW}}) = 9.3^{+1.1}_{-1.0} \text{ (stat.)} \pm 0.8 \text{ (syst.) pb}$
 $\sigma(\eta_t) = 8.8 \pm 0.5 \text{ (stat.)}^{+1.1}_{-1.3} \text{ (syst.) pb}$

Both ATLAS and CMS observe pseudo-scalar excess ($>5 \sigma$) at the production threshold in the dilepton channel!

Top quark pair production – Threshold

[CMS-PAS-TOP-25-002](#)

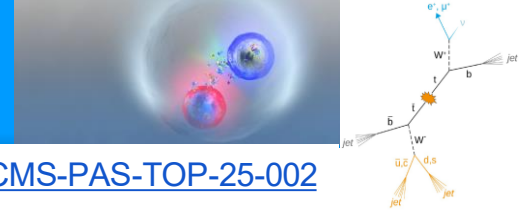

- New from CMS: **Observation of the excess in the lepton+jets channel**
- **Probe relative velocity β_t^*** : magnitude of the velocity ($|\mathbf{p}|/E$) of the leptonic top in the ZMF of the hadronic top
 - Directly related to the invariant $t\bar{t}$ mass but less sensitive to e.g. jet energy scale uncertainties.
- Combined with the angular $t\bar{t}$ system spin and parity sensible observables (lepton and down type quark have the highest spin analyser power)
- NN used to assign jets to the top quark and find the d quark: pick combination with highest score S_{NN} .
- Categorise based on the number of b-jets and S_{NN} : (1b, 2b), (S_{low} , S_{high})

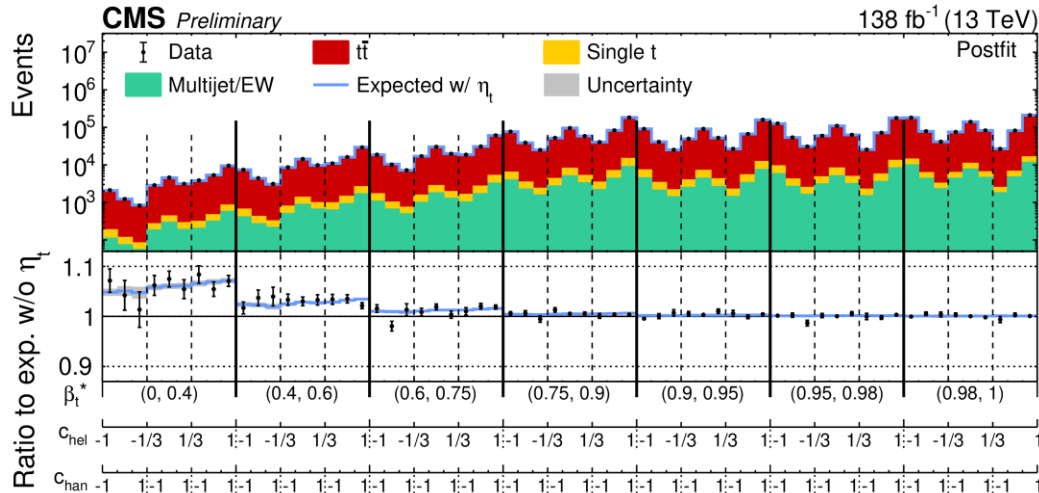

$$\frac{m^2(t\bar{t}) - m^2(t_\ell) - m^2(t_h)}{2m(t_\ell)m(t_h)} = \frac{1}{\sqrt{1 - \beta_t^{*2}}}$$

$$\sigma(\eta_t) = 5.1 \pm 0.9 \text{ pb}$$

$$\sigma(t\bar{t}_{GFRW}) = 2.8 \pm 0.5 \text{ pb}$$

Excess well compatible with SM hypothesis of quasi-bound states dominated by 1S_0
 Further improvements in signal and background modelling needed to understand the excess.

Single top production

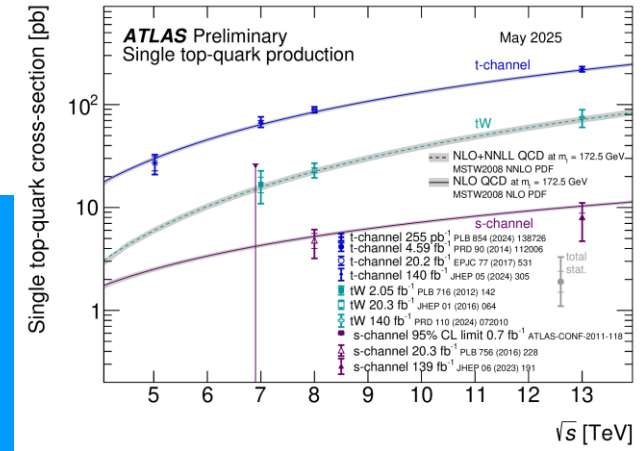
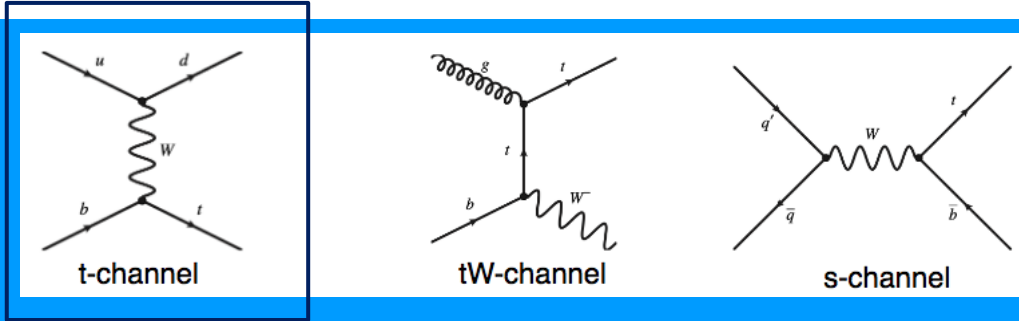

- 10-200 pb production cross section \rightarrow ~30M single top quark events (~5 events/s) at $\sqrt{s}=13$ TeV.
- Subdominant production processes when compared to $t\bar{t}$ (~1-2 orders) \rightarrow MVA techniques to extract signal
- Single top EW production allows to probe the Wtb vertex for new physics.
- Top quarks are expected to be polarised (as opposed to top-pair production).

Covered in this talk:

- Highlights on t-channel inclusive and differential cross section.
- Four-fold angular decay rate in t-channel

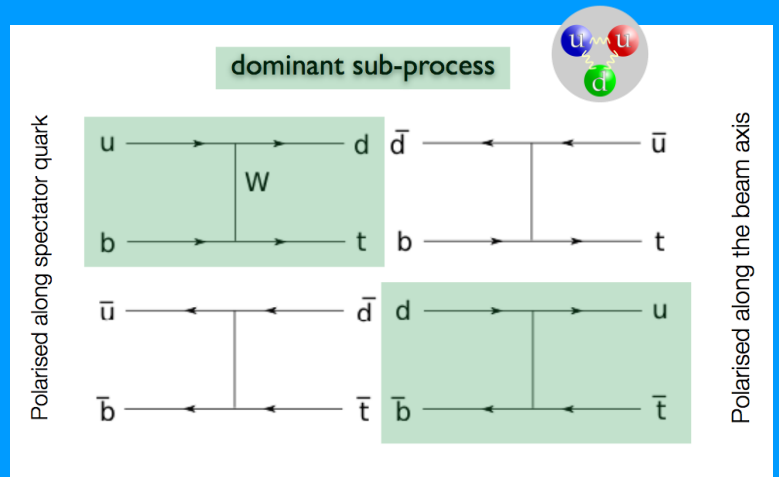

Single top production – Cross section

Single top EW production processes measured inclusively and differentially at various CM energies.

Two examples as highlight in the **t-channel** using the top leptonic decay channel:

- **CMS**: Using a small (302 pb^{-1}), but low pile-up dataset ($\langle \mu \rangle < 2$) at $\sqrt{s} = 5.02 \text{ TeV}$
- **ATLAS**: differential measurement using the full Run-2 dataset at $\sqrt{s} = 13 \text{ TeV}$

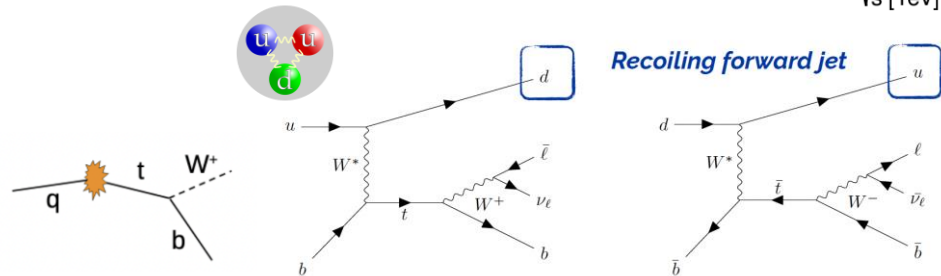
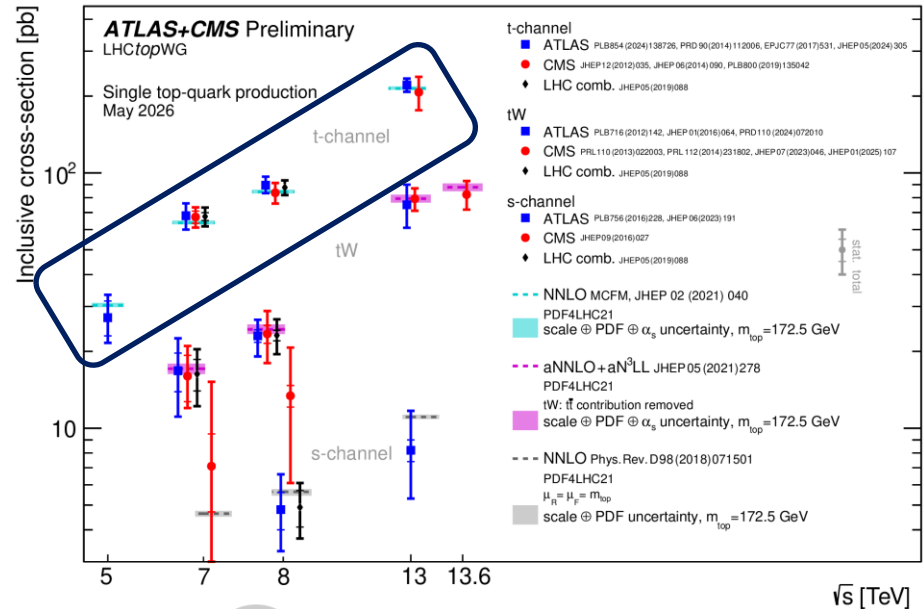
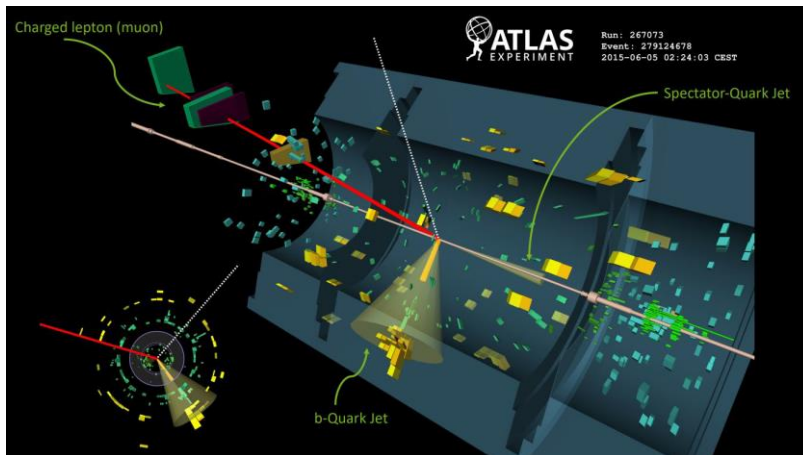

Single top production – Cross section

- $\sqrt{s} = 5.02$ TeV, $\langle \mu \rangle > 2 \rightarrow$ cleaner detector environment, and improved detection and reconstruction.
- Profiled maximum likelihood fit to observables in twelve event categories defined in terms of the number of jets, b-tagged jets, lepton flavour and electrical charge.
- MVA score used in the 2j1b categories (W+jets dominant BG), while for other categories ($t\bar{t}$ main BG) the pseudo-rapidity of the un-tagged jet is used.

$$\sigma(tq + \bar{t}q) = 30.2_{-3.6}^{+3.7}(\text{stat})_{-4.2}^{+4.4}(\text{syst}) \pm 0.6(\text{lumi}) \text{ pb}$$

standard model prediction of $30.3_{-0.5}^{+0.7}$ pb.

$$\sigma(tq) = 21.1_{-2.8}^{+3.0}(\text{stat})_{-2.7}^{+2.8}(\text{syst}) \pm 0.4(\text{lumi})$$

$$\sigma(\bar{t}q) = 8.2_{-2.3}^{+2.4}(\text{stat})_{-1.8}^{+1.9}(\text{syst}) \pm 0.2(\text{lumi}) \text{ pb}$$

$$\mathcal{R}_{t\text{-ch}} = 2.6_{-0.7}^{+1.1}(\text{stat})_{-0.2}^{+0.7}(\text{syst})$$

$$|f_{LV} V_{tb}| = 0.92 \pm 0.09(\text{exp}) \pm 0.01(\text{theo})$$



[PAS-TOP-24-011](#)

First t-channel measurement by CMS at $\sqrt{s} = 5.02$ TeV
 19% precision in inclusive measurement (12% statistical, 14% systematics).
 Dominant uncertainties: b-tagging efficiencies and W+ c jets normalisation.
 All measurements in good agreement with the SM.
 Input for PDF fits: b PDF at lower $\sqrt{s} \rightarrow$ higher x

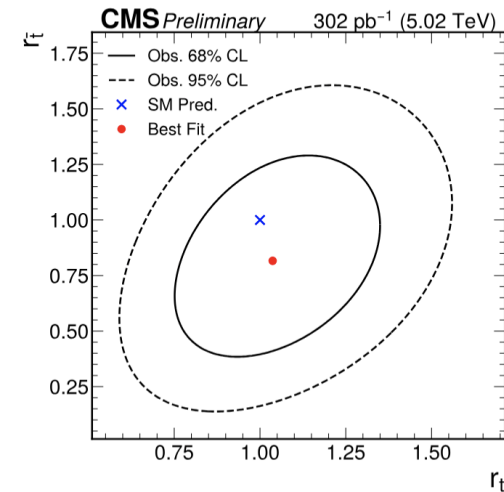
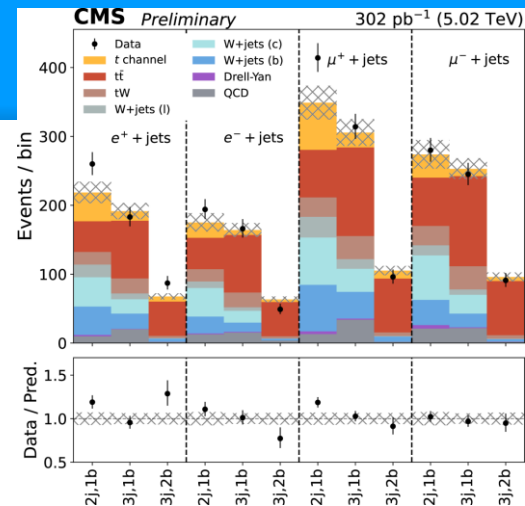

Single top production – Cross section

- First separate differential measurement for $t\bar{q}$ and $\bar{t}q$, and ratio, as a function of p_T and absolute rapidity of the anti-top/top, at parton level at $\sqrt{s}=13$ TeV: $p_T(t)$ interesting to compare event generators, $|y(t)|$ interesting for proton PDF fits.
- EFT interpretation to constrain the $C_{Qq}^{3,1}$ four-quark operator Wilson coefficient, accounting for the dependency of the selection efficiency with $C_{Qq}^{3,1}$

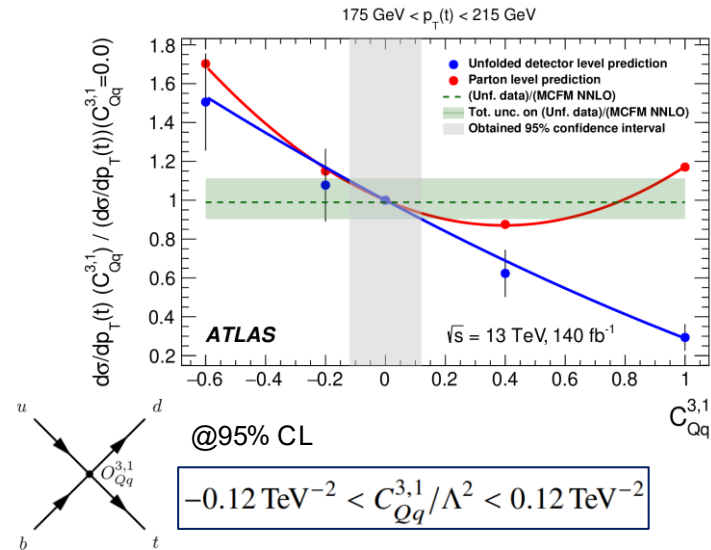
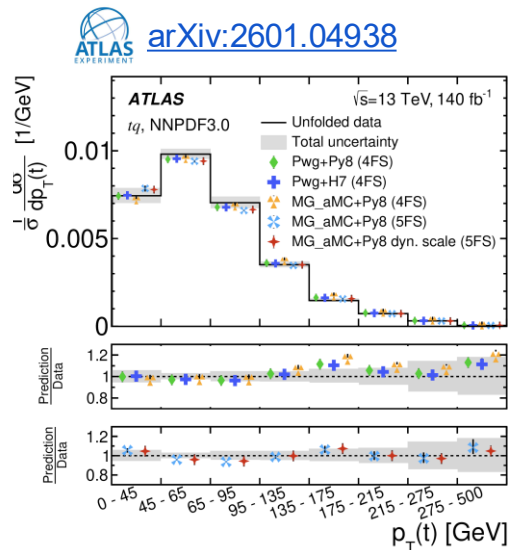
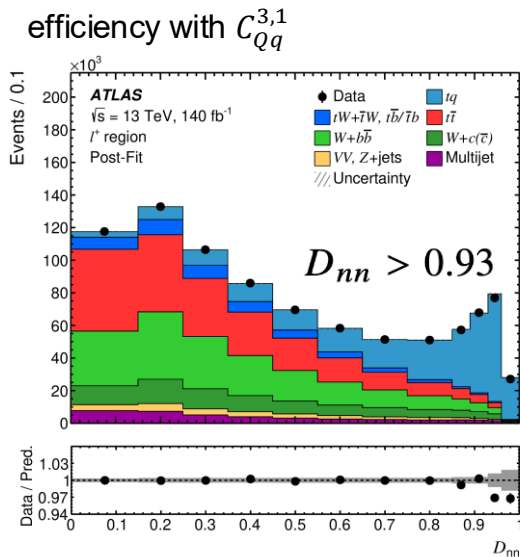

Significant reduction of uncertainties compared to the 8 TeV measurements and p_T range extended to 500 GeV.

- Uncertainty dominated by signal modelling in the absolute and normalised differential cross-sections.
- Statistical uncertainty significant in high- p_T region of absolute differential cross-sections, normalised differential cross sections and in cross section ratios.

Single top production – angular observables

- Measurement of the fourfold differential angular decay rate of single top quarks produced in the t-channel (polarisation allows to probe imaginary part of Lagrangian).
- Limits on EFT Wilson coefficients affecting the Wtb vertex and the production vertex are set.
- Innovative analysis method that employs Fourier techniques to achieve high sensitivity.

- Polar, azimuthal angle of top decay: θ, ϕ
- Polar, azimuthal angle angle of W decay: θ^*, ϕ^*

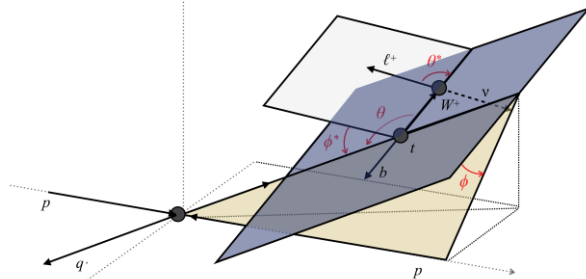
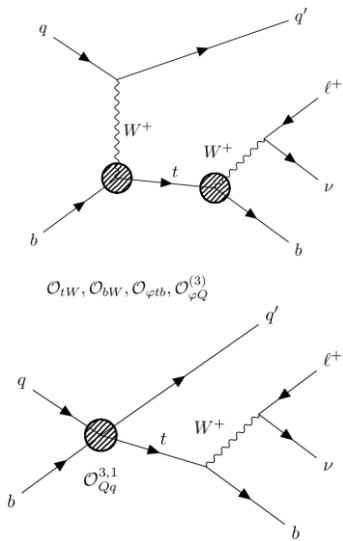

$$\frac{1}{\Gamma} \frac{d\Gamma}{d\Omega d\Omega^*} = \sum_{j_1 j_2 m' m} c_{m' m}^{j_1 j_2} M_{m' m}^{j_1 j_2}(\phi, \theta, \phi^*, \theta^*)$$

arXiv:2510.23372

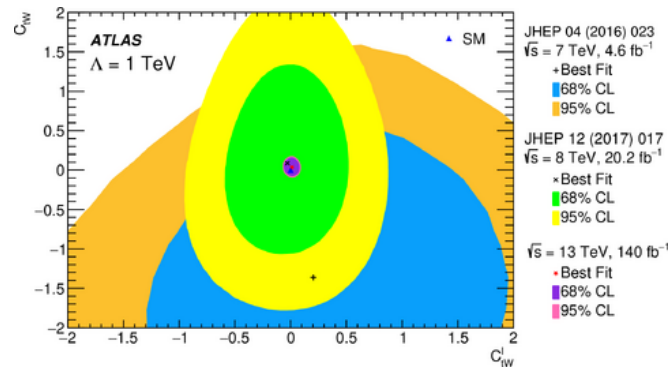
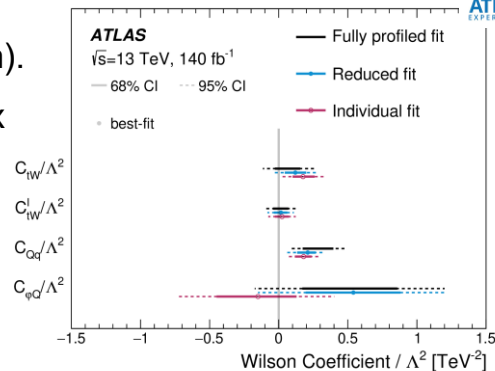

Good agreement with SM. Tightest constraints on C_{tW} (real and imaginary parts) ever.

Simultaneous measurement of $t\bar{t}\gamma$ and $tq\gamma$



CMS-PAS-TOP-25-003

- Complementary to the dedicated ATLAS $tq\gamma$ analysis reporting first observation ([PRL 131, \(2023\) 181901](#))
- Photons can originate from the initial incoming quarks, the top (direct access to top- γ coupling), or the top quark decay products.
- Events are selected by requiring one lepton, at least one photon, and at least two jets, with at least one b-tagged.
- Dedicated BDT trained to separate $t\bar{t}\gamma$ and $tq\gamma$

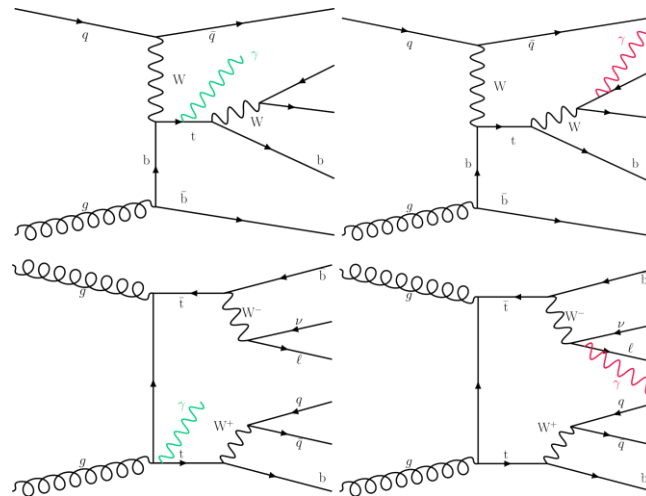

Measurements in fiducial region (high momentum and isolated photons)

	Theory:
$\sigma_{\text{tot. } t\gamma q}^{\text{mea.}} = 237_{-17}^{+17} \text{ fb,}$	$207.6 \pm 8.5 \text{ fb}$
$\sigma_{\text{tot. } t\bar{t}\gamma}^{\text{mea.}} = 1445_{-81}^{+81} \text{ fb}$	$1370 \pm 23 \text{ fb}$

Provides first differential measurements as a function of lepton, photon, light jet, and top quark kinematic observables for $tq\gamma$ at parton and particle level. Results consistent with SM predictions.

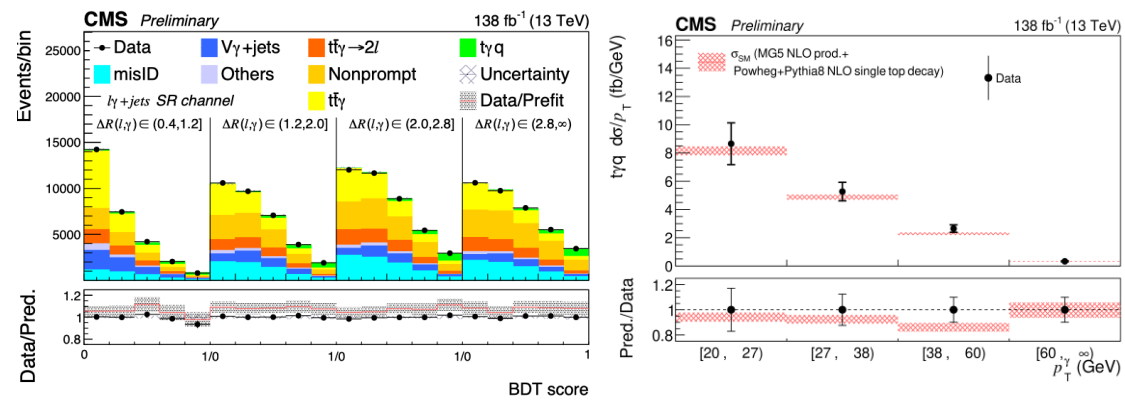

First observation of $t\bar{t}\gamma\gamma$



Phys. Lett. B 874 (2026) 140195

- A much rarer process with an expected production cross section - $O(2 \text{ fb})$ - at the per mille level compared to $t\bar{t}\gamma$.
- Relevant irreducible background for the $t\bar{t}H (H \rightarrow \gamma\gamma)$ measurements.
- Handle to further constrain the anomalous chromomagnetic and chromoelectric dipole moments. Ratio with respect to $t\bar{t}\gamma$ could further constrain anomalous dipole moments.
- Measurement provided in a fiducial region at particle level to provide a first reference measurement for future theoretical developments.
- Fiducial region: requiring exactly two photons, one electron or muon, and at least four jets, including at least one b -jet, following the kinematic requirements at reconstruction level.

$$\sigma_{t\bar{t}\gamma\gamma} = 2.42_{-0.53}^{+0.58} \text{ fb} = 2.42_{-0.38}^{+0.46} (\text{stat})_{-0.38}^{+0.35} (\text{syst}) \text{ fb} \quad \mathbf{23\% \text{ unc.}}$$

$$R_{t\bar{t}\gamma\gamma/t\bar{t}\gamma} = (3.30_{-0.65}^{+0.70}) \times 10^{-3} = (3.30_{-0.55}^{+0.63} (\text{stat})_{-0.34}^{+0.32} (\text{syst})) \times 10^{-3} \quad \mathbf{20\% \text{ unc.}}$$

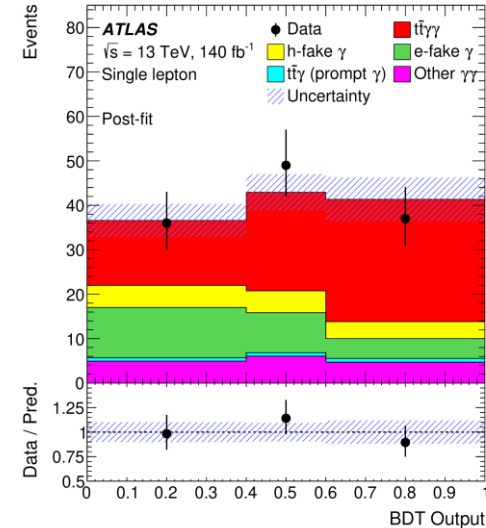
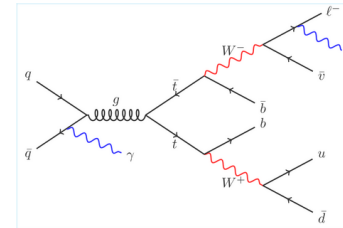
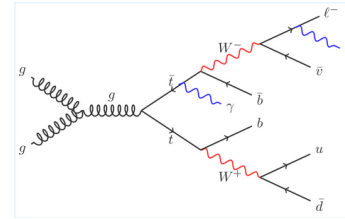

Observed (expected) significance: 5.2σ (5.7σ)
 23% relative uncert. (17% data stat, 15% syst) –
 syst. dominated by uncertainties related to jets,
 photons and fake- γ background estimation.
 The available MC prediction at LO
 underestimate the cross section as expected.

Observation of 4-tops and search for 3-tops

Four tops production

- Observation of 4-top production reported by ATLAS ([Eur. Phys. J. C 83 \(2023\) 496](#)) and CMS ([PLB 847 \(2023\) 138290](#)) with the full Run-2 dataset at $\sqrt{s} = 13$ TeV.
- Constrains on four-heavy-flavour fermion EFT operators, top yukawa and CP structure, and 3-top production also set ([CMS-PAS-TOP-24-008](#), [Eur. Phys. J. C 83 \(2023\) 496](#)).

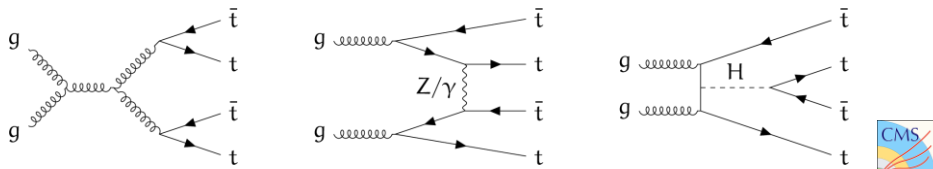

Measured cross sections:

$$\sigma(t\bar{t}t\bar{t}) = 22.5^{+4.7}_{-4.3}(\text{stat})^{+4.6}_{-3.4}(\text{syst}) \text{ fb} = 22.5^{+6.6}_{-5.5} \text{ fb}$$

$$\sigma(t\bar{t}t\bar{t}) = 18.9^{+3.7}_{-3.5}(\text{stat})^{+2.5}_{-2.1} \text{ fb} = 18.9^{+4.4}_{-4.0} \text{ fb}$$

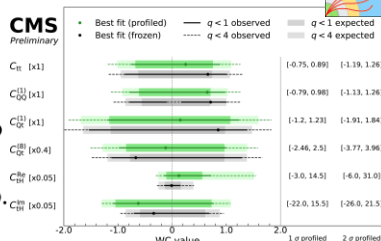

SM prediction:
 12.0 ± 2.4 fb (NLO QCD+NLO EW)
 $13.4^{+1.0}_{-1.8}$ fb (+soft gluon resummation corrections at NLL)

Processes	95% CL cross section interval [fb]	
	$\mu_{t\bar{t}t\bar{t}} = 1$	$\mu_{t\bar{t}t\bar{t}} = 1.9$
$t\bar{t}t\bar{t}$	[4.7, 60]	[0, 41]
$t\bar{t}t\bar{t}W$	[3.1, 43]	[0, 30]
$t\bar{t}t\bar{t}q$	[0, 144]	[0, 100]

Three tops production



[CMS-PAS-TOP-24-006](#)

- First dedicated analysis targeting 3-tops production
- SM: in association with a W boson (tttW) or with a light-flavor or bottom quark (tttq) $\rightarrow 2.05 \text{ fb}^{-1}$
- More rare than tttt (odd number of top quarks requiring weak interactions, and only flavor-changing charged currents at leading order).
- Observed upper limit of 25 fb at 95% CL.

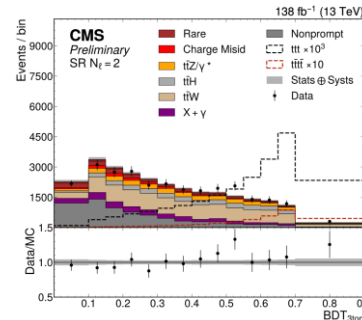
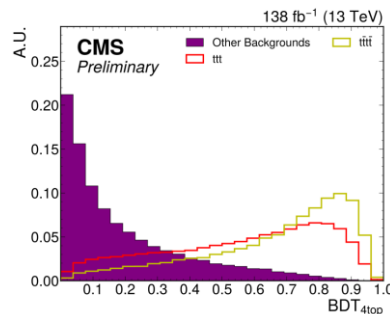
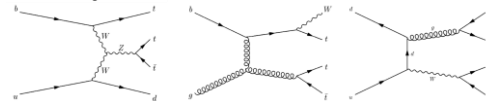

Top quark mass

A fundamental parameter of the Standard Model that can only be determined experimentally

Direct measurements

- Extraction of the mass as defined in the MC by comparing kinematic observables to MC predictions
- sub-GeV precision
- Best precision from LHC Run-1 combination: **172.52 ± 0.33 GeV**

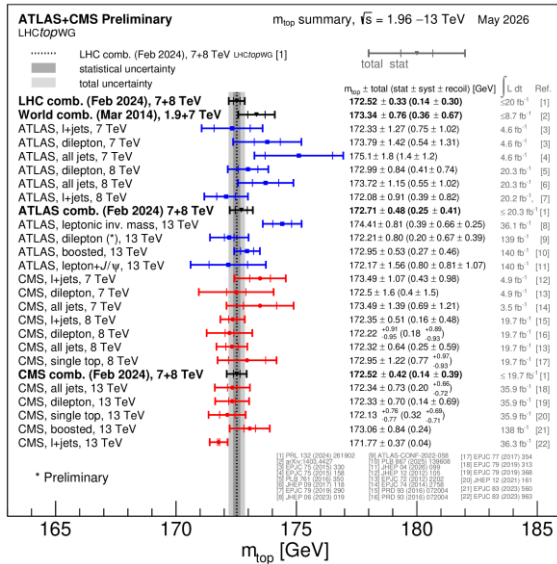

Indirect measurements

- Pole mass/ $M\bar{S}$ mass extracted by comparing inclusive or differential measured cross sections to theoretical perturbative predictions.
- Lower precision $O(1 \text{ GeV})$

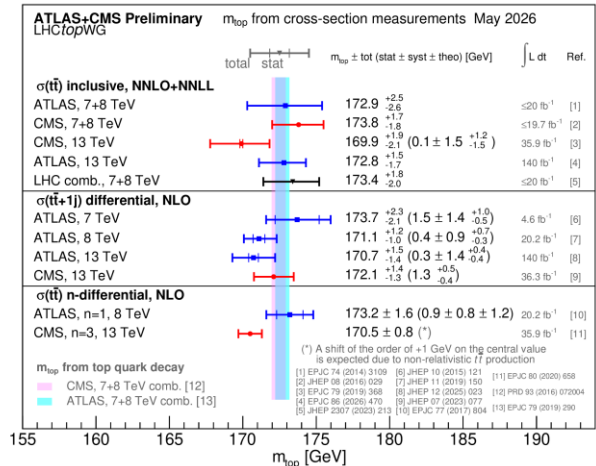

Wide variety of observables and techniques (see excellent review from CMS: [Physics Reports 1115 \(2025\) 116](#))

Top quark mass most precise direct measurements

Legacy combination of Run-1 ATLAS+CMS top mass measurement ([PRL 132 \(2024\) 261902](#)): 6 (ATLAS) and 9 (CMS) individual results:

$$m_t = 172.52 \pm 0.14 \text{ (stat)} \pm 0.30 \text{ (syst)} \text{ GeV}$$

Dominant uncertainties: b-jet energy scale, b-tagging, ME generator, jet energy scale



Most precise CMS measurement

36.3 fb⁻¹ data at $\sqrt{s} = 13$ TeV, in the lepton+jets channel

Profile likelihood fit up to four observables per event

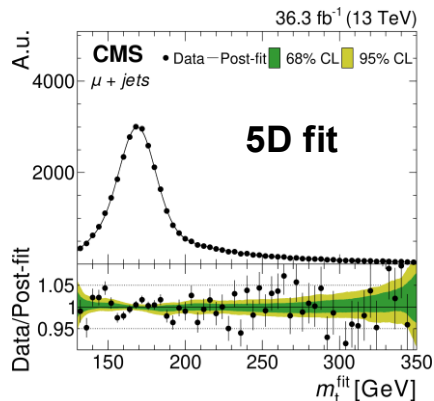

[Eur. Phys. J. C 83 \(2023\) 963](#)

$$171.77 \pm 0.37 \text{ GeV}$$

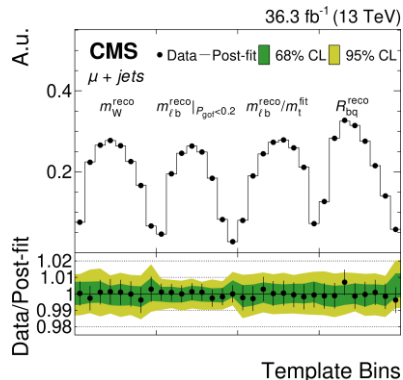

Dominant uncertainties:
Jet energy scale and
signal modelling



Most precise ATLAS measurement

Full Run-2 dataset (140 fb⁻¹, $\sqrt{s} = 13$ TeV)

Lepton+jets channel with a high energy hadronically decaying top reconstructed as a single large-radius jet (J).

Mean boosted jet mass depends linearly on top mass.

Simultaneous fit to boosted jet mass and two additional observables to reduce systematics.

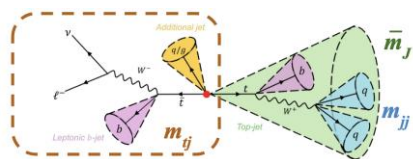

$$m_t = 172.95 \pm 0.53 \text{ GeV}$$

[Phys. Lett. B 867 \(2025\) 139608](#)

Dominant uncertainties: Jet energy
scale, signal modelling

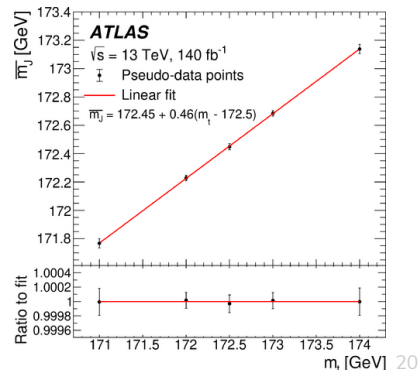

Top quark mass indirect measurements using $t\bar{t}$ +jet events

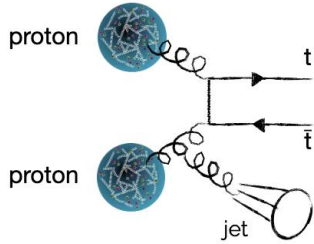

$$\mathcal{R}(\rho_s; m_t^{\text{pole}}) = \frac{1}{\sigma_{t\bar{t}+1\text{-jet}}} \cdot \frac{d\sigma_{t\bar{t}+1\text{-jet}}}{d\rho_s}$$

with $\rho_s = \frac{2m_0}{\sqrt{s_{t\bar{t}+1\text{-jet}}}} m_0 = 170 \text{ GeV}$

- Enhanced sensitivity due to additional jet
- Long history of measurements at 7, 8, 13 TeV
 - ATLAS lepton+jets (7, 8 TeV), recent dilepton (13 TeV)
 - CMS dilepton (13 TeV)

JHEP 07 (2023) 077

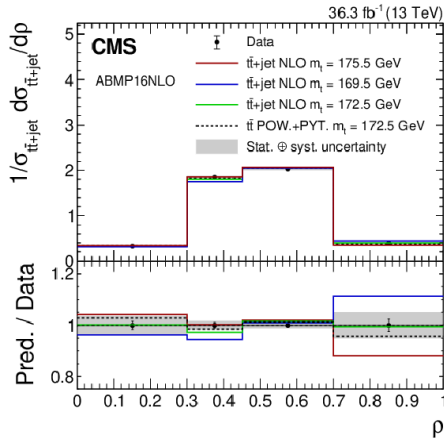

JHEP 12 (2025) 023

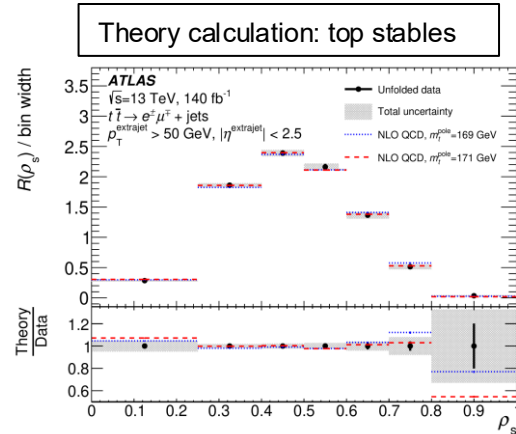

Theory calculation (cross-check): includes top decays to the dilepton final state and off-shell effects

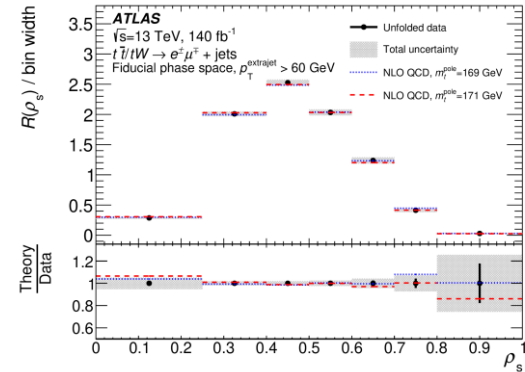

$$m_t^{\text{pole}} = 172.93 \pm 1.36 \text{ GeV}$$



$$m_t^{\text{pole}} = 170.7 \pm 1.5 \text{ GeV}$$

Dominant systematic uncertainty: signal modelling, theory, Jet energy scale

Future prospects

- Improvements on the leading experimental (jet energy scale and b-tagging) and $t\bar{t}$ modelling uncertainties can be expected in the future.
- The HL-LHC dataset ($\sqrt{s} = 14$ TeV, $3ab^{-1}$): explore rare processes in more detail and increase precision in tails of distributions.
- Joint effort from ATLAS and CMS to prepare input to the 2026 update of the European Strategy for Particle Physics ([arXiv:2504.00672](https://arxiv.org/abs/2504.00672))
- Based on Run-1/Run-2 published analyses
- Assuming a common scenario S2:
 - Increased luminosity: $3 ab^{-1}$ per experiment
 - Decreases exp. systematic uncertainties with statistical nature by \sqrt{L}
 - 50% decrease in theoretical + modelling uncertainties by theory community
 - MC statistical uncertainties negligible.

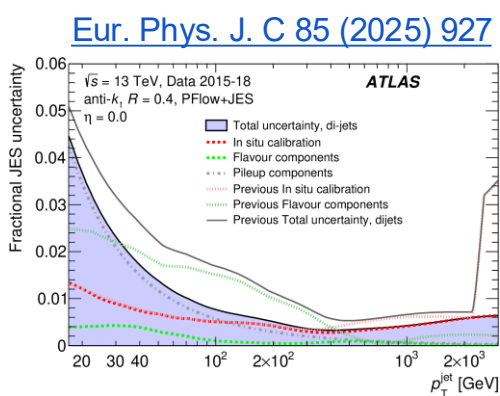

Improved JES from single-particle measurements

CMS-DP-2024-066

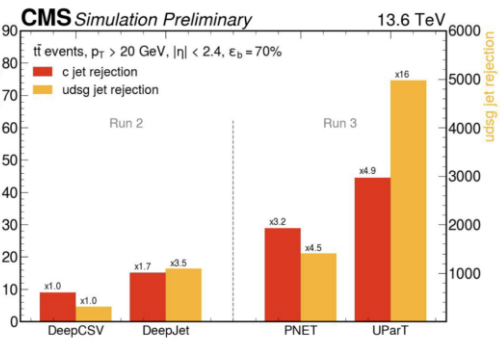

Unified Particle Transformer model applied to Run-3 data

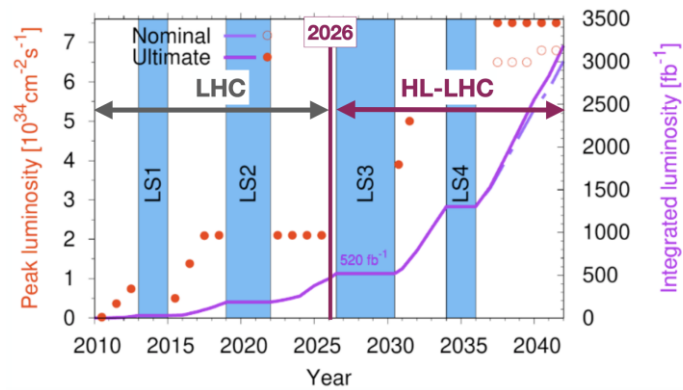

Top mass projections

- In the long term, the precision of m_{top} will be driven by the technique with the greatest theoretical improvement

Extrapolations based on $t\bar{t}$ +jet

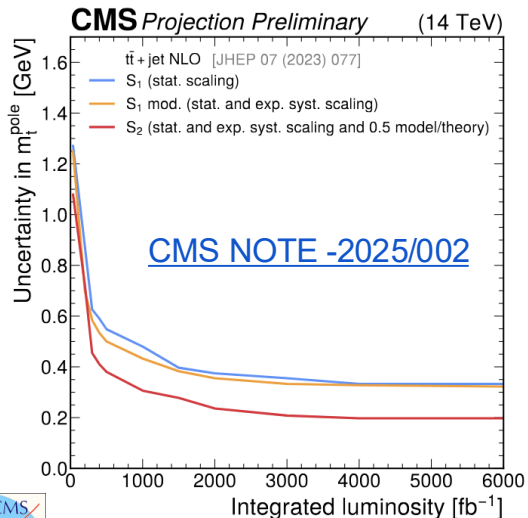

Profiling \rightarrow ~ 200 MeV



Without profiling \rightarrow ~ 600 MeV

[ATL-PHYS-PUB-2025-019](#)

Extrapolations based on boosted $t\bar{t}$

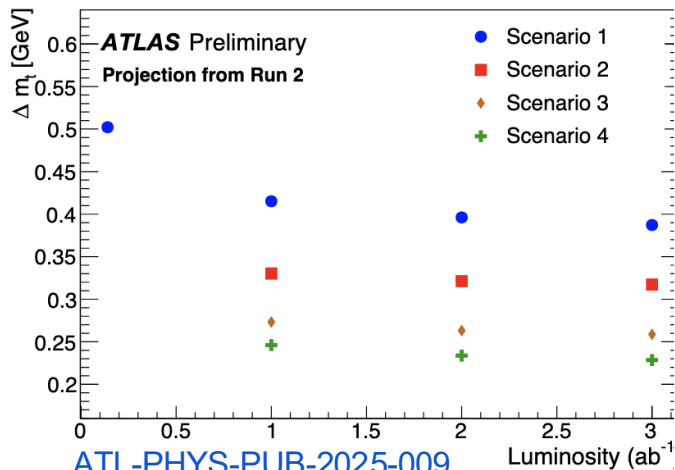

200-300 MeV



~ 400 MeV

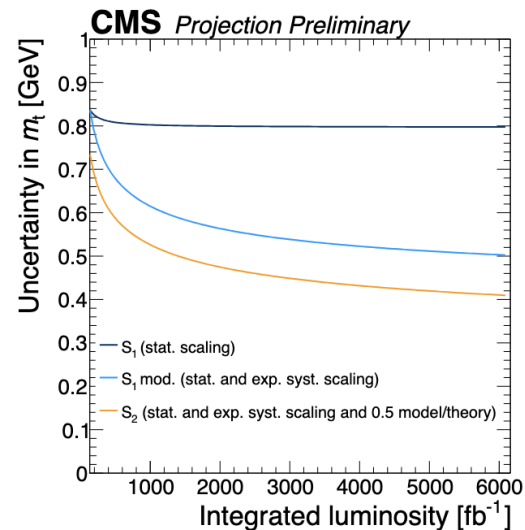

Rare processes projections

Four-top production

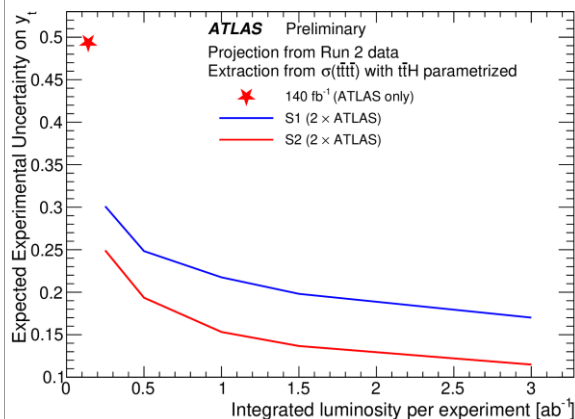
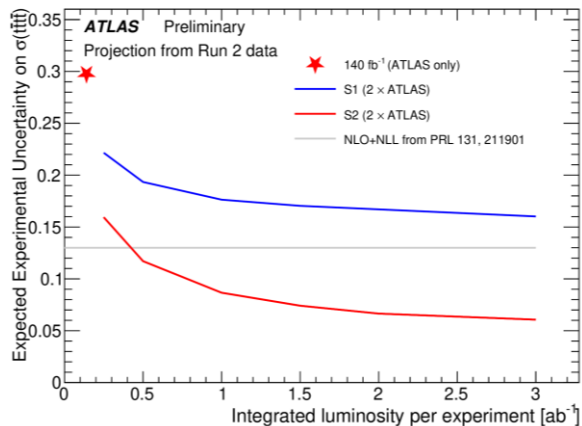

- 6% precision on four-top cross section expected (significantly smaller than current theory uncertainty)

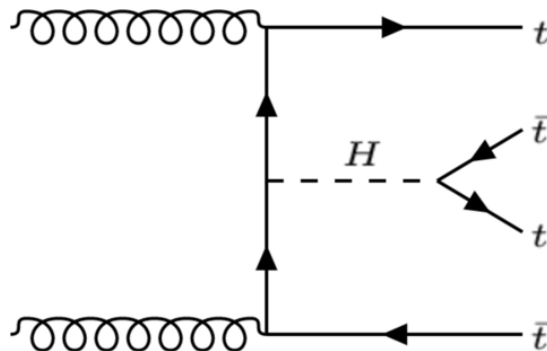

[ATL-PHYS-PUB-2025-017](#)

Top pair production in association with photon/Z

Sensitivity on probing the EFT operators related to the electroweak dipole moments of the top quark from $p_T(\gamma/Z)$ in $t\bar{t}(\gamma/Z)$ production

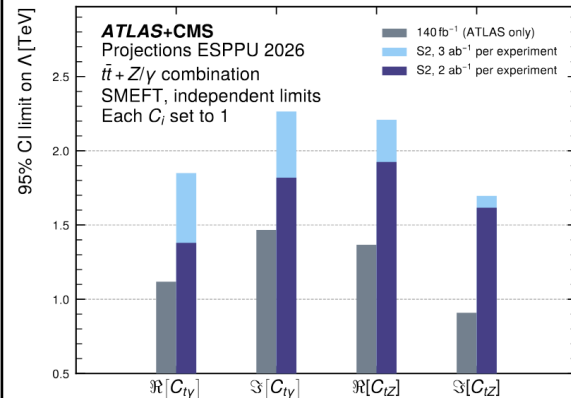

[ATL-PHYS-PUB-2025-015](#)

Outlook

- The understanding of the top quark has come a long way since its first observation at Tevatron more than 30 years ago.
- The LHC offers a rich and diverse top quark physics program including precise tests of the SM as well as studies sensitive to new physics.
- Measurements are now so precise that are sensitive to subtle effects.
- Many legacy Run-2 results available and Run-3 analyses coming along.
- The upcoming HL-LHC data will allow us to explore rare processes in more detail and increase precision in tails of distributions.



Backup

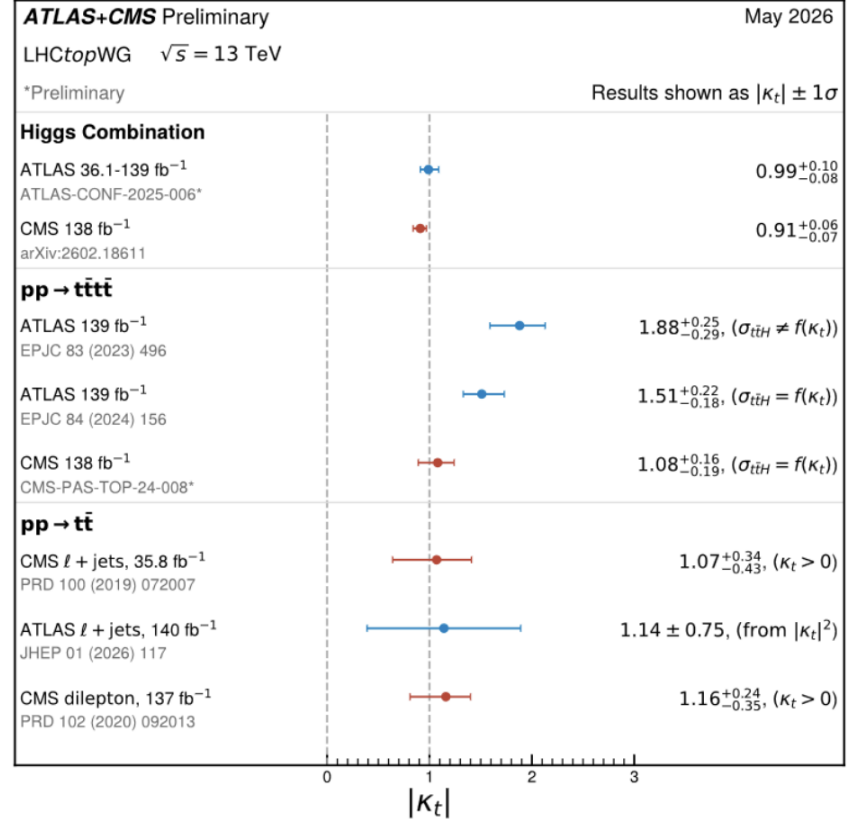
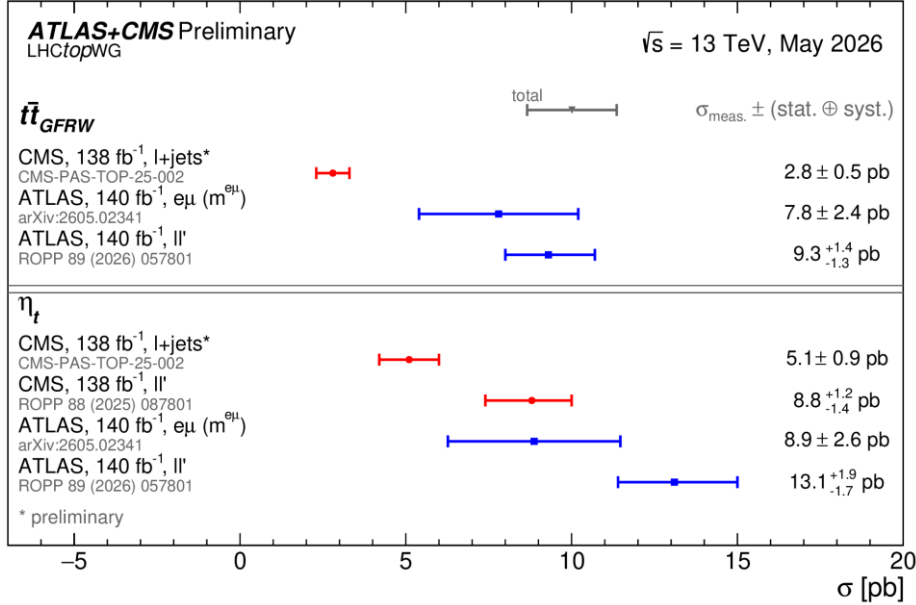

Top quark pair production – Quantum properties

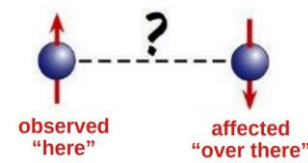

- The spins of the tops produced at the LHC can also be interpreted as a pair of qubits
- The spin density matrix is the ingredient to measure all quantum state properties.
- There are specific entanglement witness ($D < -1/3$, $\tilde{D} > 1/3$)
 - Spin correlation and top quark polarisation already measured with Run 1 data (by CMS (PRL 112 (2014) 182001) and ATLAS (PRL 108, 212001 (2012) in dilepton channels).
 - Quantum entanglement more recently observed with Run 2 data.

$$\rho = \frac{1}{4} \left(I \otimes I + \sum_i P_i \sigma_i \otimes I + \sum_j \bar{P}_j I \otimes \sigma_j - \sum_{ij} C_{ij} \sigma_i \otimes \sigma_j \right)$$

Spin polarisation and correlation coefficients

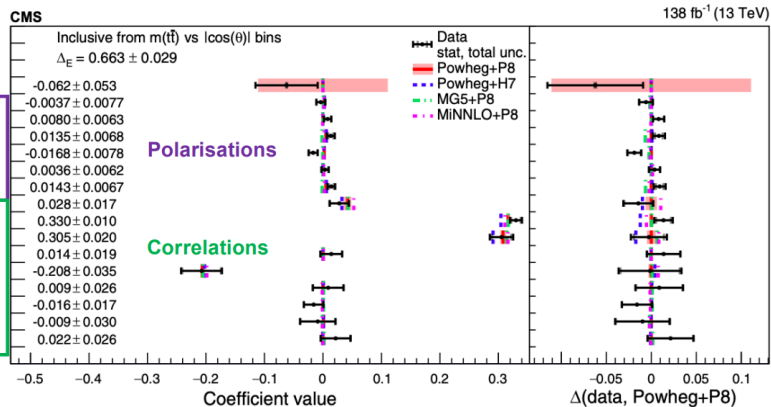

Extraction of all 15 coefficients in the lepton+jets channel [PRD 110(2024)112016]]

Entanglement

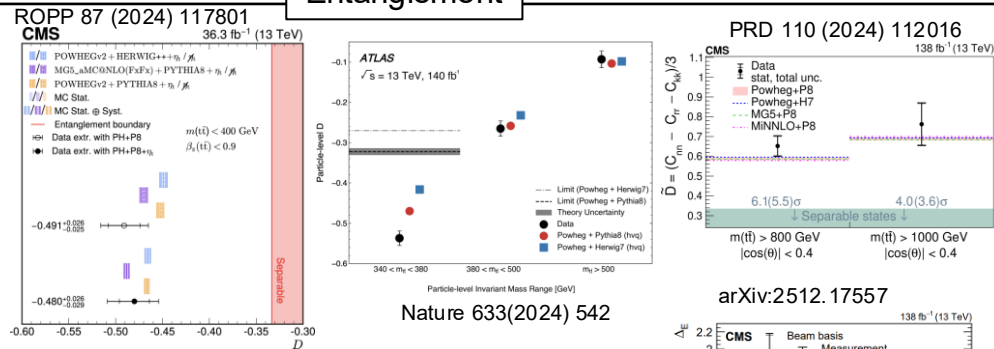

A stronger entanglement is observed in data compared to nominal predictions at threshold (better agreement when accounting for the pseudo-scalar production).
Measurements using helicity basis (relative to top direction of flight) now also extended to beam basis by CMS.

First observation of tWZ



PRL 136 (2026) 081802

- Direct access to top-boson EW couplings and additional sensitivity to BSM effects.
- Evidence (3.4σ) by CMS in 2024 ([Phys. Lett. B 855 \(2024\) 138815](#)).
- 200 fb⁻¹: Combination of Run 2 (2016-18, 138 fb⁻¹) and Run 3 (2022-23, 62 fb⁻¹) data.
- Sensitivity increased by advanced ML and reconstruction techniques.
- At NLO, interference with ttZ process.
- Enhanced ttZ/tWZ separation wrt Run 2 analysis thanks to the usage of transformers.

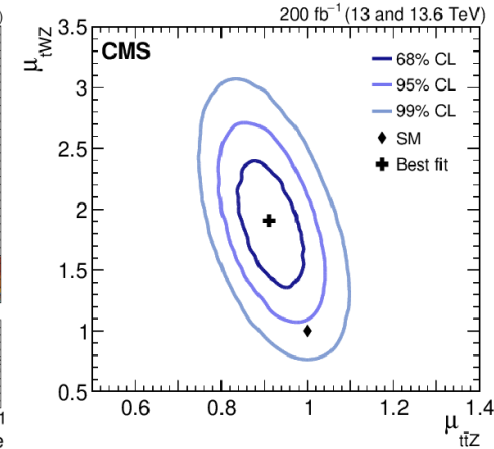
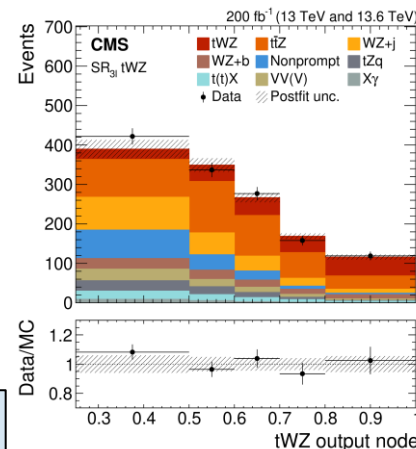
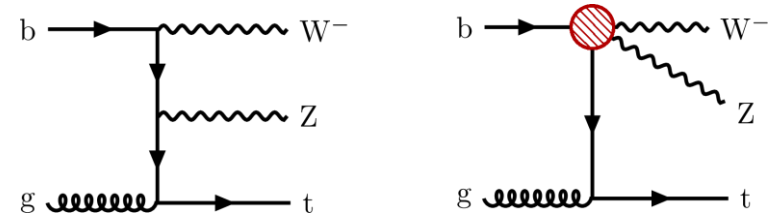

Observed significance for tWZ: 5.8σ (3.5σ expected).
 Signal strength agrees with the SM within 2.3σ
 Uncertainty dominated by statistics, major systematics: Normalisations of $t\bar{t}Z$ (14%), $WZ+b$ (9%) and jet energy corrections (6%).

$\sqrt{s} = 13 \text{ TeV: } \sigma_{tWZ} = 248 \pm 38 \text{ (stat)} \pm 35 \text{ (syst) fb}$
 $\sqrt{s} = 13.6 \text{ TeV: } \sigma_{tWZ} = 242 \pm 62 \text{ (stat)} \pm 46 \text{ (syst) fb}$