



**Cristian Pira** (INFN LNL) on behalf of ISAS WP3 Collaboration

# WP3: $\text{Nb}_3\text{Sn}$ on Cu films for 4.2K cavity operation



**Second Annual Meeting @HZB, April 23, 2026**

All information contained in this presentation and any accompanying documents is for iSAS project only, and must be treated as strictly confidential.  
Any dissemination, distribution or other use of this information without the consent of its owner is prohibited.



Funded by the European Union. Views and opinions expressed are however those of the authors only and do not necessarily reflect those of the European Union or the European Commission. Neither the European Union nor the granting authority can be held responsible for them.

**Energy saving** is mandatory for **next generation accelerators**...

...**cryogenics** is one of the **larger energy cost** in modern SRF accelerators

➔ **Move from bulk Nb @2K to Nb<sub>3</sub>Sn @4.5 K**  
**reduces cryogenic power by a factor of 3**

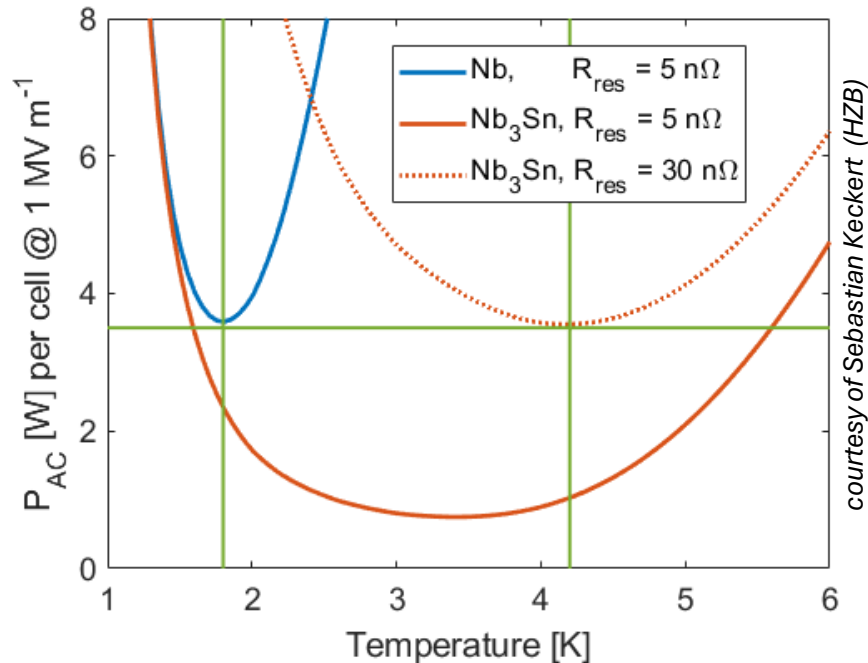

**Goal of iSAS WP3 is optimization of Nb<sub>3</sub>Sn on Cu technology**  
 focusing on **minimizing trapped flux** and increasing coating mechanical strength to allow **cavity tunability**

## Any Project a step forward in TRL

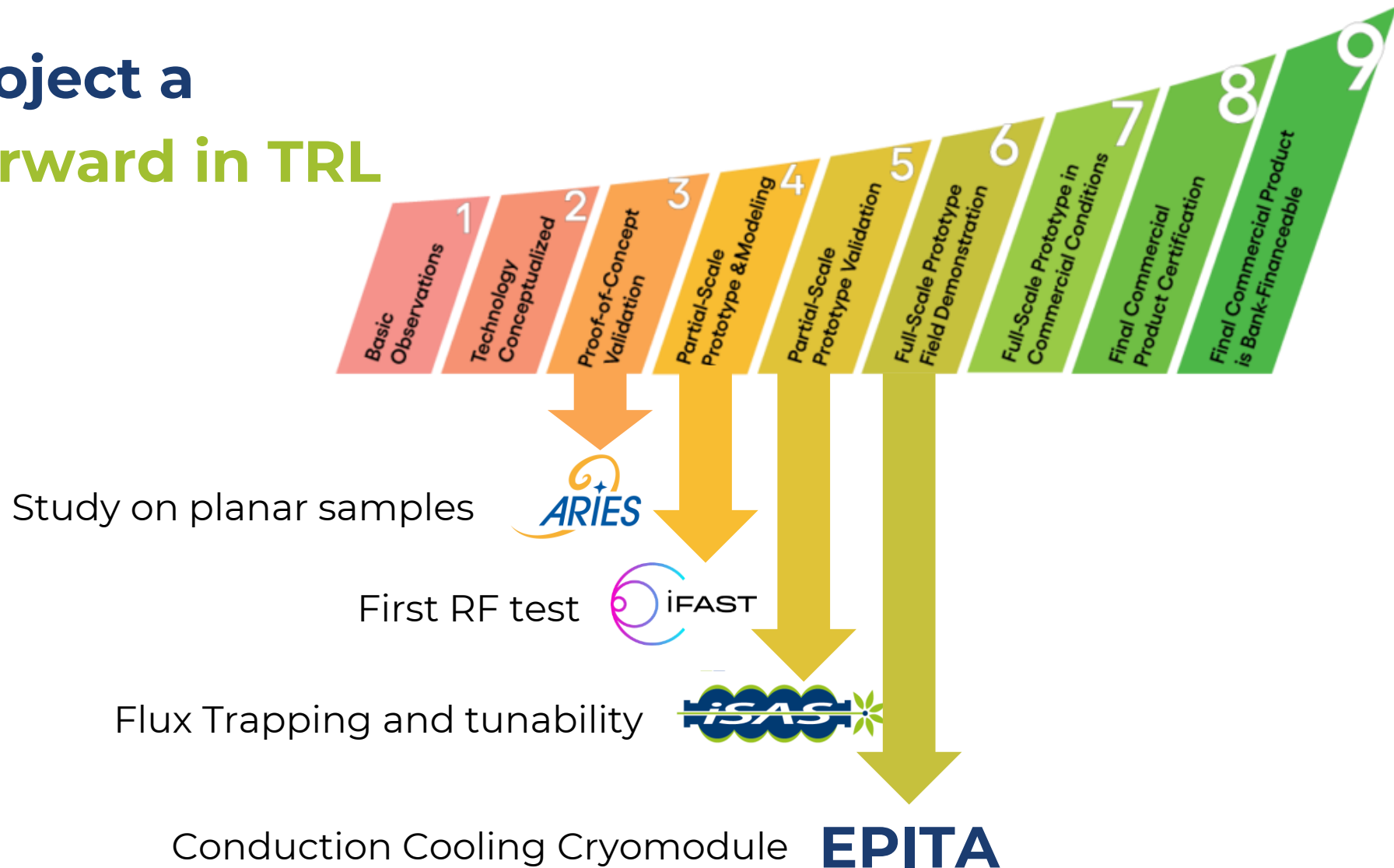

# Trapped Flux

$$Q_0 \propto \frac{1}{R_{BCS} + R_{res} + \eta S B}$$

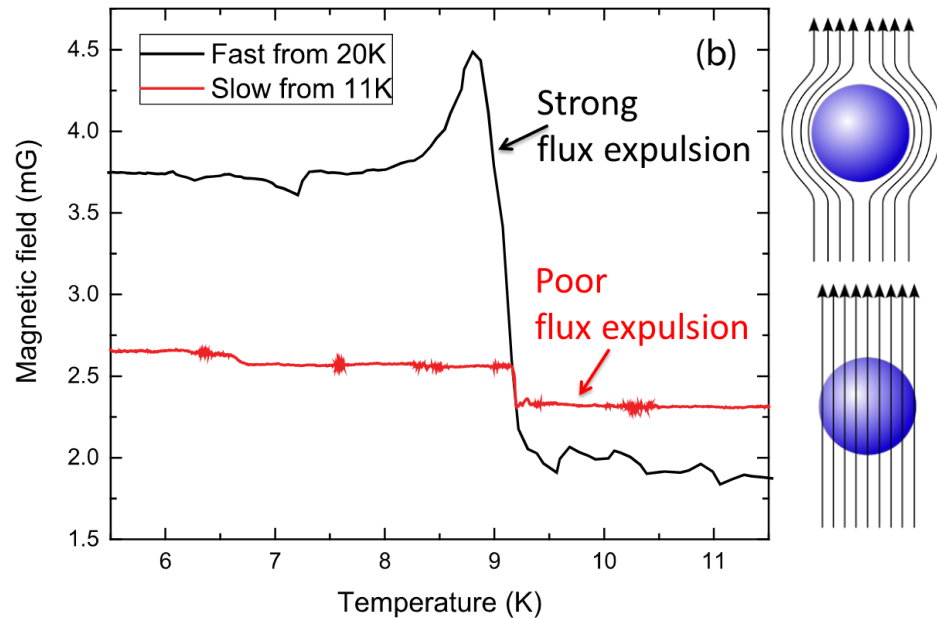

A. Romanenko, A. Grassellino, O. Melnychuk, D. A. Sergatskov, *J. Appl. Phys.* 115, 184903 (2014)

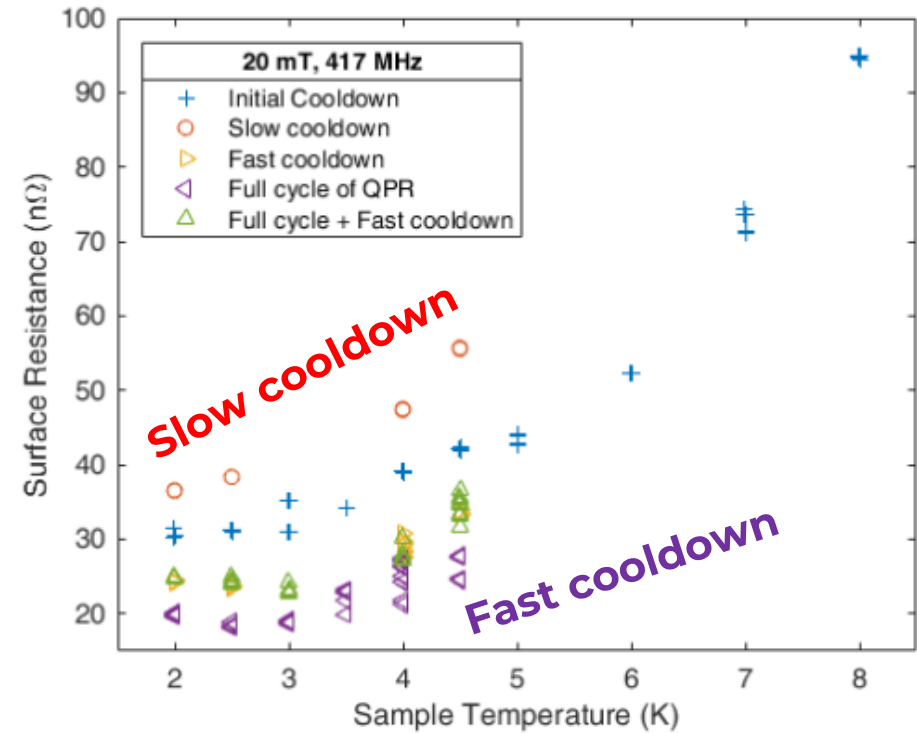

- ▶ Nb<sub>3</sub>Sn coating suffer flux trapping
- ▶ **Cooldown procedure influence R<sub>s</sub>**

# Cavity Tunability

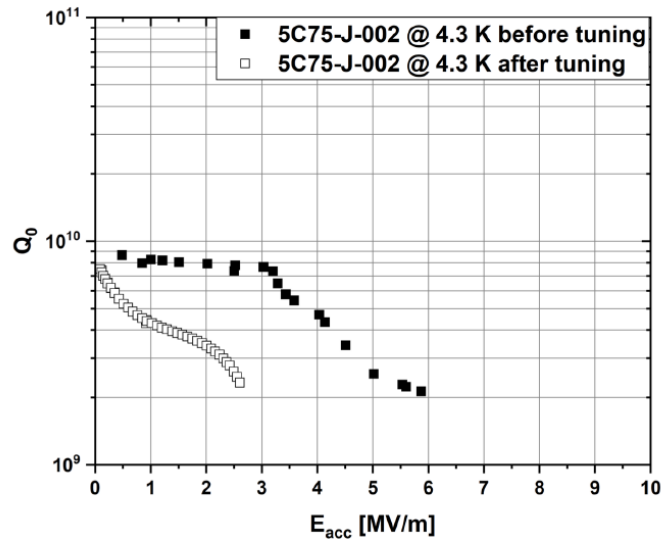

**Strong performance degradation** after **room temperature** tuning for 200 kHz

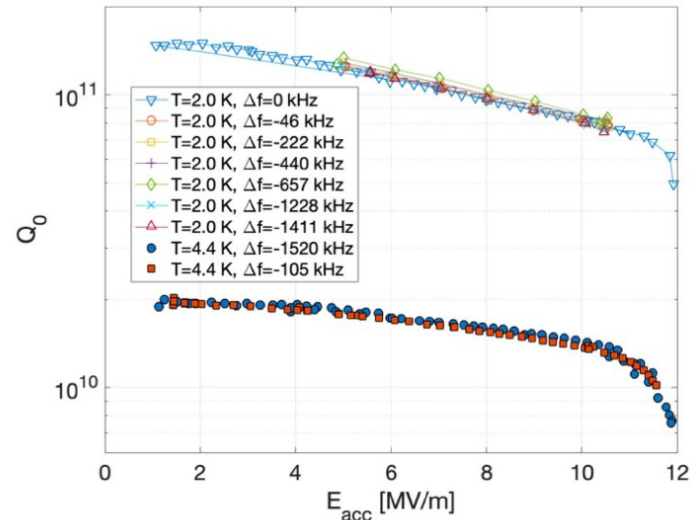

**Little change** in the coated cavity performance after tuning up to 1400 kHz at **cryogenic temperatures**

**Nb<sub>3</sub>Sn is extremely brittle**

*neev, G. (2023). Tunability/robustness of Nb3Sn (No. MILAB-SLIDES-23-402-TD). Fermi National Accelerator oratory (FNAL), Batavia, IL (United States).*

- ▶ **Vapor Tin Diffusion Nb<sub>3</sub>Sn on Nb cavities can be tuned only at cryogenic T**
- ▶ **An interlayer in Nb<sub>3</sub>Sn on Cu coatings can be added to enhance film mechanical stability and tunability**

# WP3: Nb<sub>3</sub>Sn on Cu films for 4.2K cavity operation

Institutes participating: INFN, CEA, HZB, UKRI

Convener: Cristian Pira (INFN LNL)

**INFN**  
**UKRI** Improve Nb<sub>3</sub>Sn coating performances  
(Task 3.5)

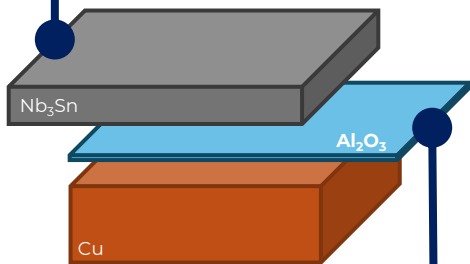

**cea** Develop an Adaptive Layer to insert between Nb<sub>3</sub>Sn coating and Cu substrate  
(Task 3.4)

**UKRI**  
**HZB** Helmholtz Zentrum Berlin flux trapping test on planar samples  
(Task 3.2)

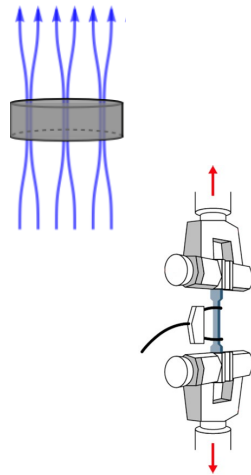

**cea** mechanical strength test on planar samples and cavities  
(Task 3.3)

**INFN**  
**UKRI** Coat a 1.3 GHz cavity with optimized recipe  
(Task 3.5)

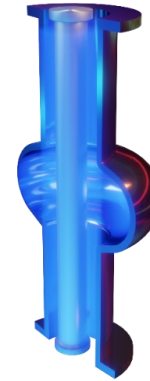

**HZB** Helmholtz Zentrum Berlin 4.2 K SRF vertical test of Nb<sub>3</sub>Sn on Cu optimized cavity  
(ISAS WP3 final goal)  
(Task 3.5)





## **WP3: Nb<sub>3</sub>Sn on Cu films for 4.2K cavity operation**

Institutes participating: INFN, CEA, HZB, UKRI

Convener: Cristian Pira (INFN LNL)

### **Task 3.1: Coordination of R&D on SC cavities – M1-M48 (INFN, CEA, HZB, UKRI) – Cristian Pira**

*This task aims to coordinate the different task activities and organize the periodic WP meetings.*

### **Task 3.2: Flux Trapping – M1-M32 (INFN, CEA, HZB, UKRI) – Oleg Malyshev**

*This task aims to minimize flux trapping in Nb<sub>3</sub>Sn thin films studying and optimizing coating parameters and cooling procedure*

### **Task 3.3: RF Tunability – M1-M32 (INFN, CEA, HZB, UKRI) – Oliver Kugeler**

*This task aims to study and improve mechanical properties of SC thin films to assess the impact of future cavity tuning during normal 4.2 K operation*

### **Task 3.4: Adaptive Layers – M1-M40 (INFN, CEA, HZB, UKRI) – Thomas Proslie**

*This task aims at developing suitable adaptive layers synthesized by Atomic Layer Deposition (ALD) to reduce the detrimental effect of mechanical deformation on the superconducting properties of Nb<sub>3</sub>Sn*

### **Task 3.5: Working Cavity – M1-M48 (INFN, CEA, HZB, UKRI) – Reza Valizadeh**

*This task encompasses the main outcome of WP3: to optimize the SC cavity coating procedure at 1.3 GHz using the experience and knowledge gained in Tasks 3.2-3.4. and demonstrate suitability for operation at 4.2 K.*

### Coordination (INFN, CEA, HZB, UKRI) – Cristian Pira

- Periodic meeting (in person and online) every 2-3 months (possibly in collaboration with I.FAST → EPITA)
- Zanon is joining WP3 meetings as industrial reviewer

**WP3 Meeting 01** - Task leaders Pre-Kick-Off remote meeting on 21/02/2024 <https://agenda.infn.it/event/40107/>

**WP3 Meeting 02** - Kick-Off meeting in Paris (hybrid) on 16/04/2024 (in collaboration with I.FAST WP9) <https://indico.cern.ch/event/1357302/sessions/528505/#20240416>

**WP3 Meeting 03** - Task Leaders remote meeting on 17/07/2024 (in collaboration with I.FAST WP9) <https://indico.cern.ch/event/1437516/>

**WP3 Meeting 04** - Hybrid meeting in Berlin on 02-03/12/2024 (in collaboration with I.FAST WP9) <https://events.hifis.net/event/1875/>

**WP3 Meeting 05** - Annual meeting in LNL (hybrid) on 12/03/2025 <https://indico.ijclab.in2p3.fr/event/11291/timetable/#20250312>

**WP3 Meeting 06** - I.FAST Annual meeting in Cracow (hybrid) on 08/04/2025 <http://indico.cern.ch/event/1464979/timetable/#20250408.detailed>

**Informal update** during SRF2025 Conference in Tokyo (21-26/09/2025)

**WP3 Meeting 07** - Online meeting on 24/11/2025 <https://indico.ijclab.in2p3.fr/event/12433/>

**WP3 Meeting 08** - Online meeting on 20/03/2026 <https://indico.ijclab.in2p3.fr/event/13566/>

**WP3 Meeting 09** - Annual meeting in HZB (hybrid) on 22/04/2026 <https://indico.ijclab.in2p3.fr/event/11960/timetable/#20260422>

## Coordination (INFN, CEA, HZB, UKRI) – Cristian Pira

✓ Milestone 39 Impact Risk Analysis WP3 – INFN – Presentation/report M24 **Completed**

Critical risks & risk management strategy					
Risk No	Description	Probability (scale 1<4)	Severity (scale 1<4)	Criticality (PxS)	Mitigation measures
1	Beneficiary leaves the project	1	3	3	Pro-actively: documentation, collaboration, strong coordination; Post-facto: redistribute tasks
2	Lack of candidates for temporary positions	1	4	4	Maximize job advertisements as early as possible and as wide as possible (professional networks), leverage on the iSAS consortium
3	<b>Appearance of small defects on the superconducting layers dramatically affecting the RF performance</b>	3	4	12	<b>Test the coatings on smaller prototypes before depositing on the 1.3 GHz prototype; thermometry measurements will identify defects and help improving deposition (Task 3.5)</b>
4	Scaling the SC coatings from planar samples to 3D geometry more difficult than expected	2	3	6	Additional R&D on small 3D structures to find and solve technical issues in advance (Task 3.2, Task 3.4)
5	<b>Fragility of A15 film may results in reduced tunability of the coated cavity</b>	3	4	12	<b>Initial test on small sample in Task 3.3 to optimize thin-film coating procedure, followed by coating on a 1.3 GHz cavity in Task 3.2</b>
6	Delamination of ALD layers on Cu at high Temperature	1	1	1	Test of multilayers and different alloys to mitigate this risk
7	Further increase of costs for Helium and/or power	1	3	3	Proportional reduction of number of tests or test duration

# Flux Trapping (INFN, CEA, HZB, UKRI) – Oleg Malyshev

## Objectives

- ▶ Explore new coating parameters for planar samples and small resonators to minimize flux trapping in SC A15 films.
- ▶ Upgrade the STFC choke cavity and the HZB QPR to support detailed flux trapping analyses of coated superconducting films.
- ▶ Characterize trapped flux, flux viscosity and the interaction with the RF field with SC A15 films in small resonators and samples with the upgraded systems.

 **Deliverable 3.2** Flux trapping Report on flux dynamics study in Nb<sub>3</sub>Sn on Cu samples - *HZB - Report M30* **On track**

 **Milestone 3.1** Modification of choke cavity for flux trapping study - *Engineering report M12* **Completed**

# 4 Characterization Facilities Updated during ISAS



**Choke Cavity Field Penetration Facility**  
( $R_S$  measurements with 7.8 GHz cavity)

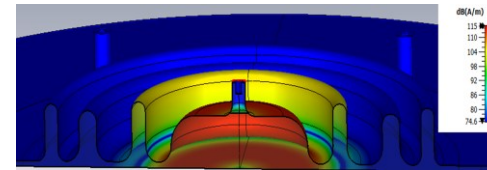

**Magnetic Field Penetration Facility**

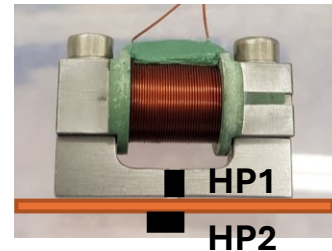

**CRAFT Facility** (Measurement of flux trapping and flux dynamics)



**Quadrupole Resonator (QPR) Facility**

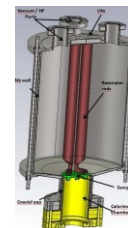

## Choke Cavity Facility

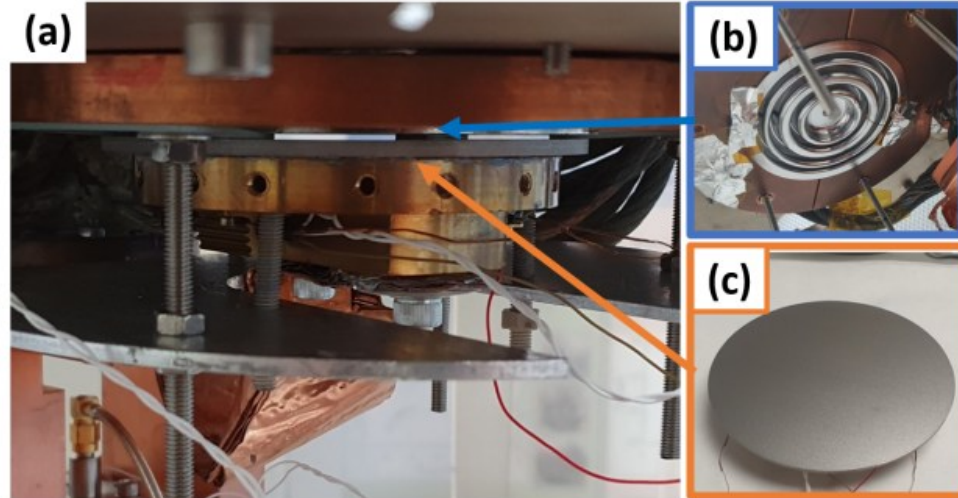

Measuring  $R_s$  and  $T_{c-RF}$  of these samples with the choke cavity facility of samples

### SAMPLES

**Substrates:** 100 mm diameter disks with thickness of 2-3 mm made of Cu or Nb

**Coating: Nb and Nb<sub>3</sub>Sn** (different deposition parameters explored: temperature, time, power, DC, HIPIMS, etc.)

## Full magnetic field penetration facility

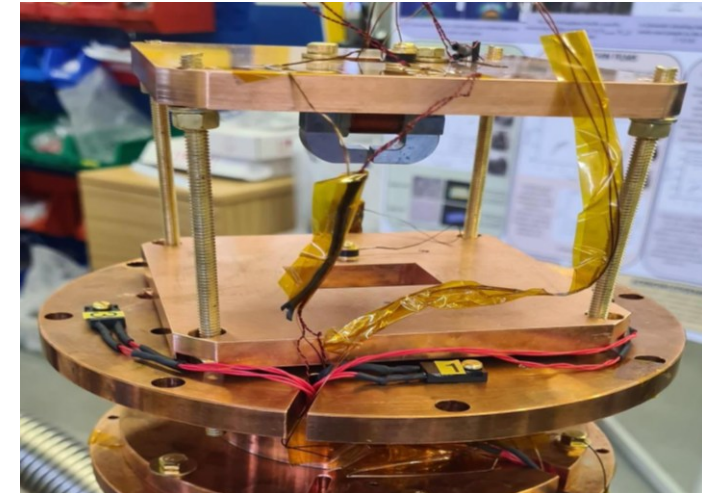

Testing the same samples with magnetic field penetration facility for full penetration magnetic field  $B_{fp}(T)$ , residual magnetisation  $B_{res}(T)$  and  $T_{c-dc}$

Relation between  $R_s(7.8 \text{ GHz})$  and  $B_{fp}$  measured at 4.2 K

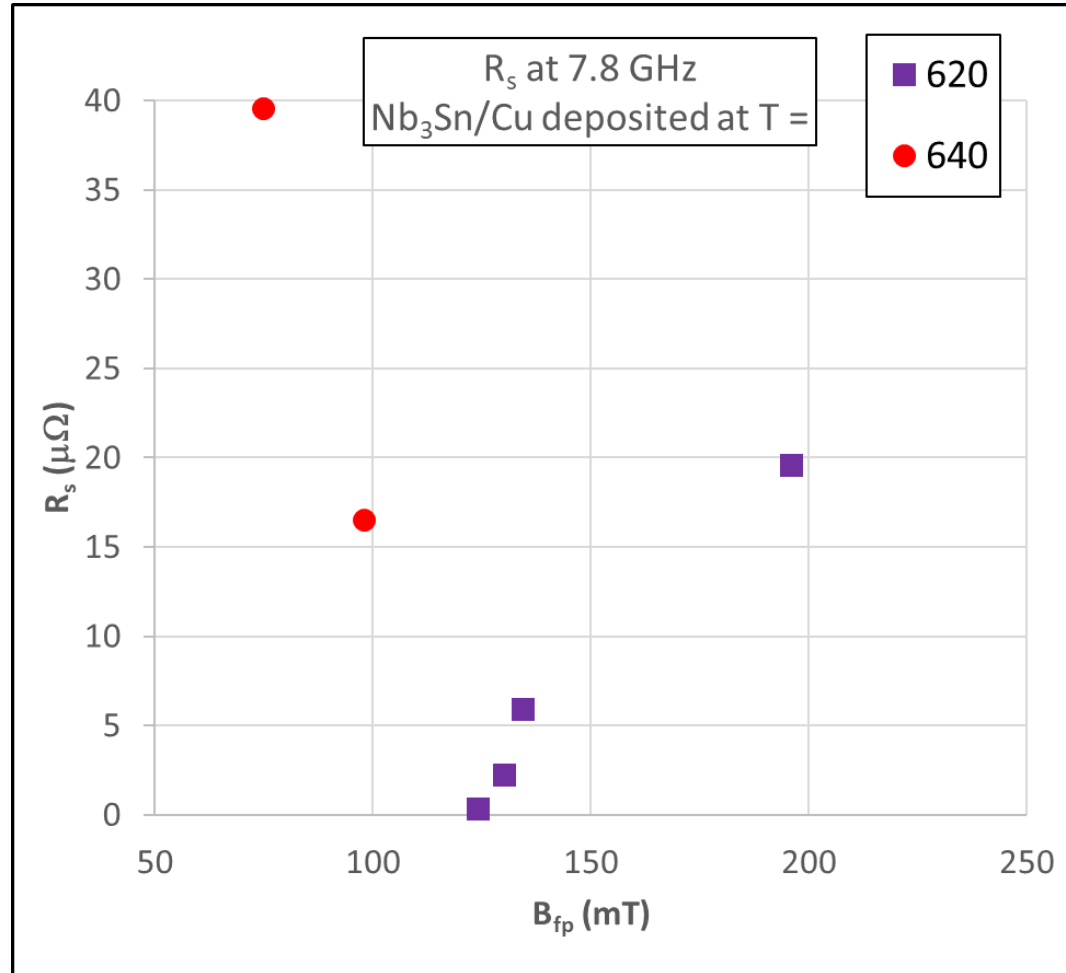

Corelation between  $T_c$ ,  $B_{fp}$  measured at 4.2 K and  $B_{res}$  measured at 4.2 and 10 K

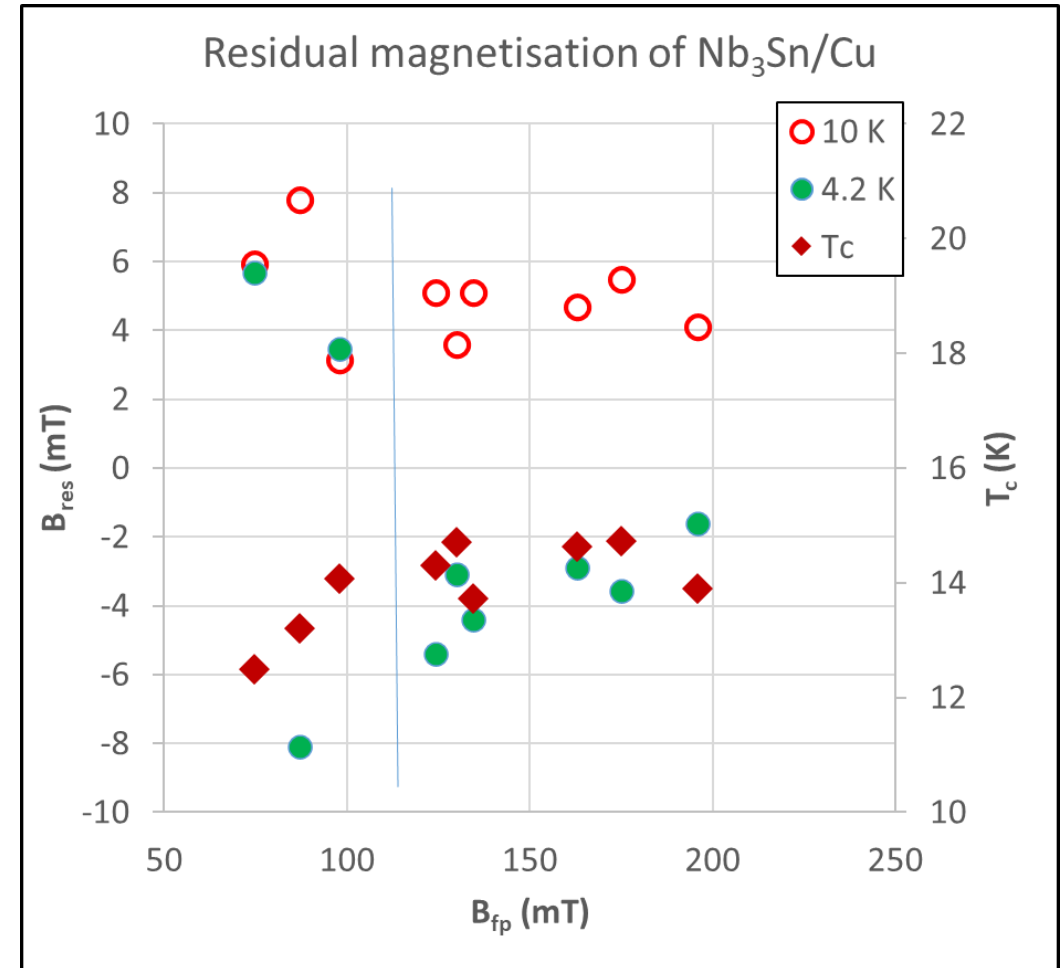

Relation between  $T_c$  and  $B_{fp}$  measured at 4.2 K as a function of deposition temperature

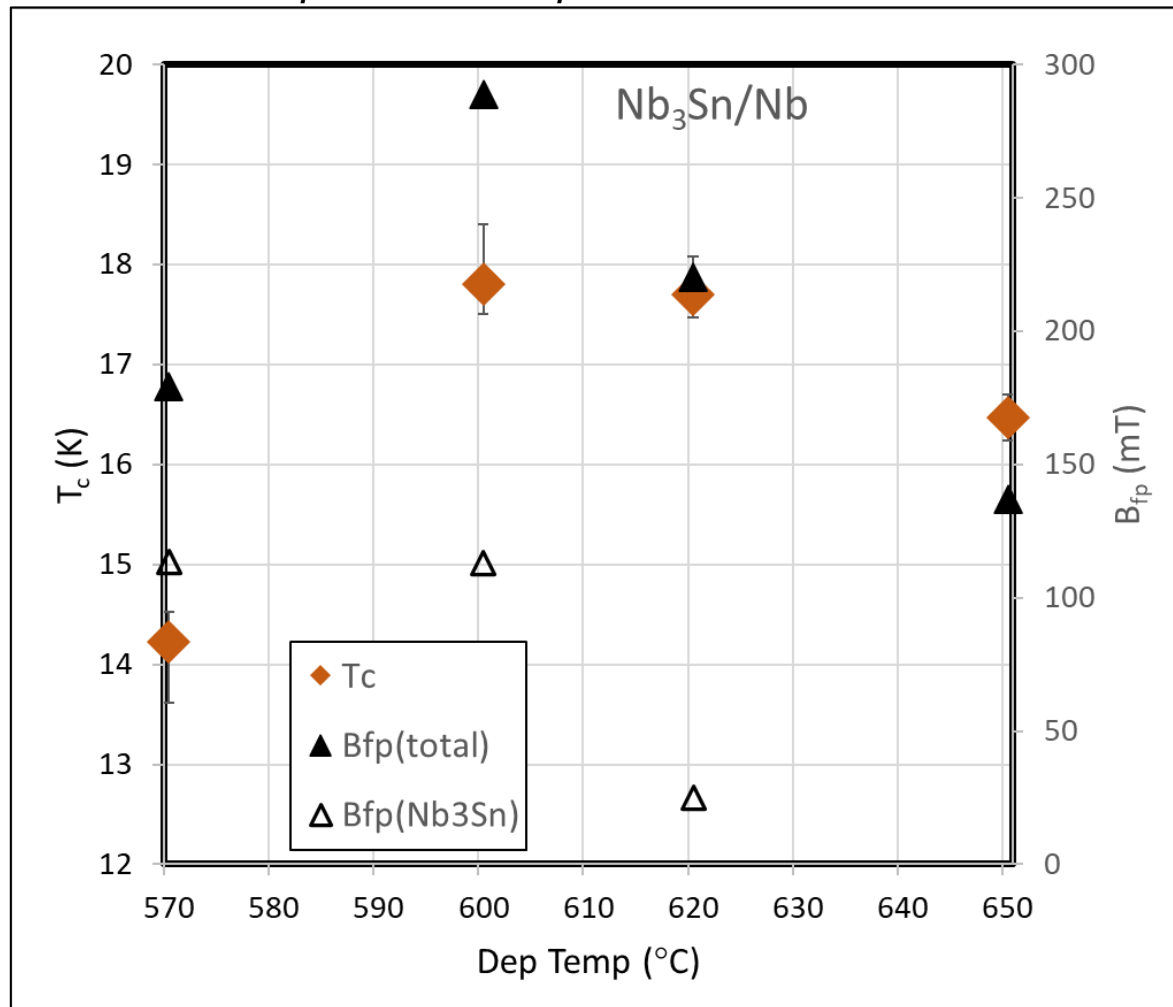

Corelation between  $T_c$ ,  $\Delta B_{fp}$  measured at 4.2 K and  $B_{res}$  measured at 4.2 and 10 K

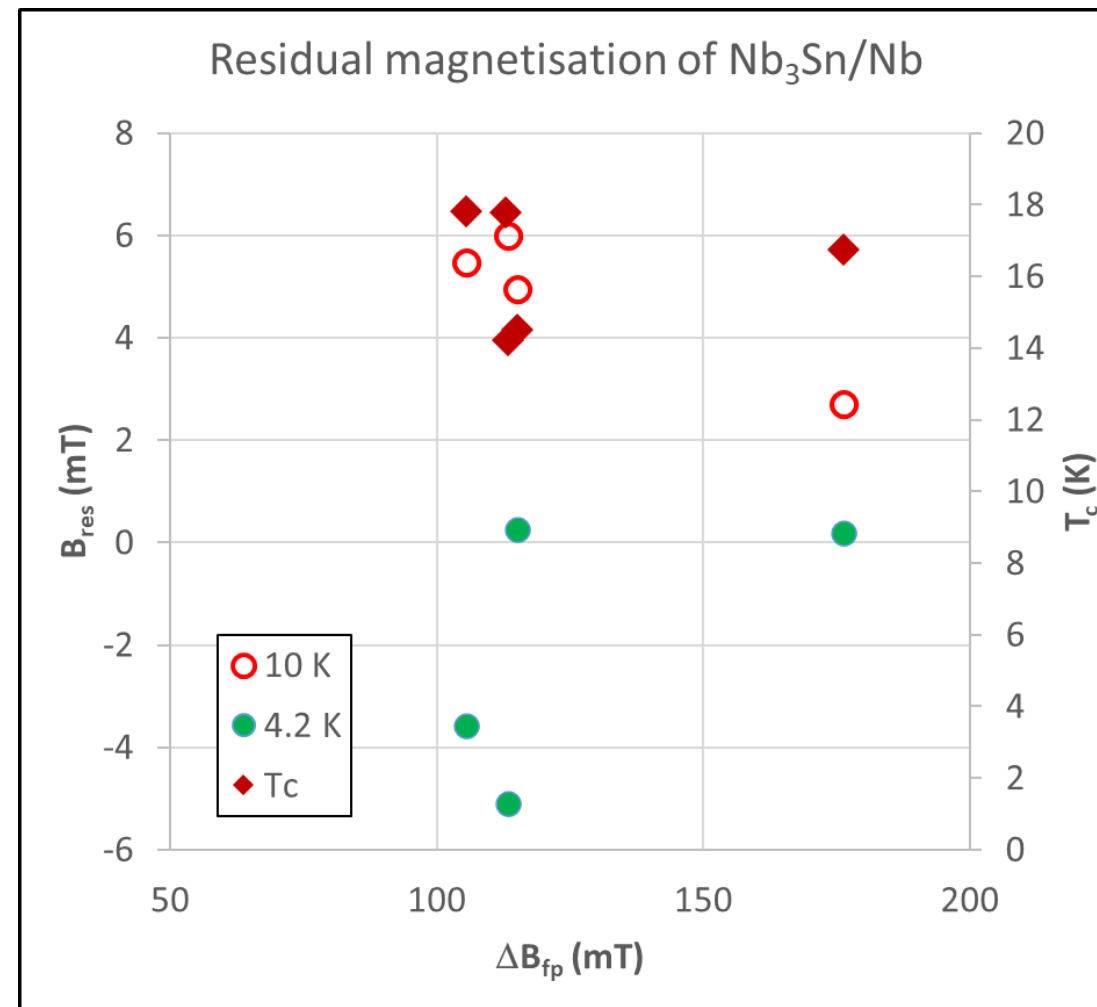

## CRAFT Facility

- 2 cryocoolers to cool down sample
- Sample (100x60x3)mm<sup>3</sup>, clamped in copper blocks at either end
- Two heaters at the end of the blocks allow for precise control of temperature gradient and cool down rate
- Multiple AMR sensors for magnetic field measurements
- grouping of 3 sensors to measure field vector in 3d
- 15 AMR sensor groups measure magnetic field just above the sample
- 2 Cernox sensors measure temperature gradient across sample
- Active field compensation with three Helmholtz-coils
- Minimum flux density at location of reference sensors < 30nT
- Maximum flux density 220μT

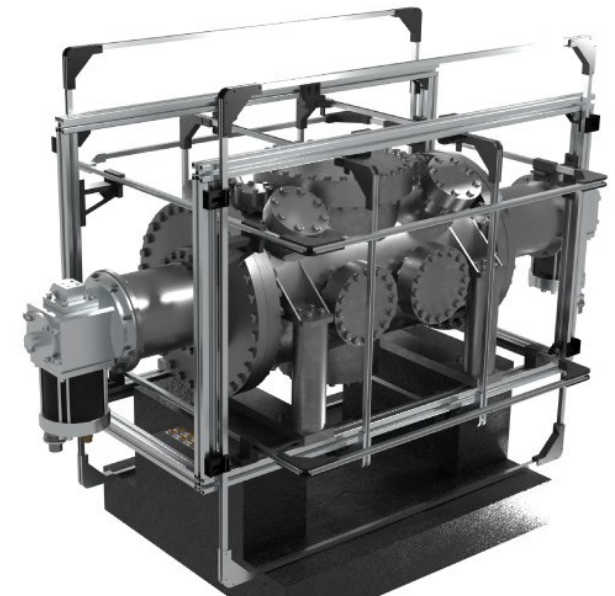
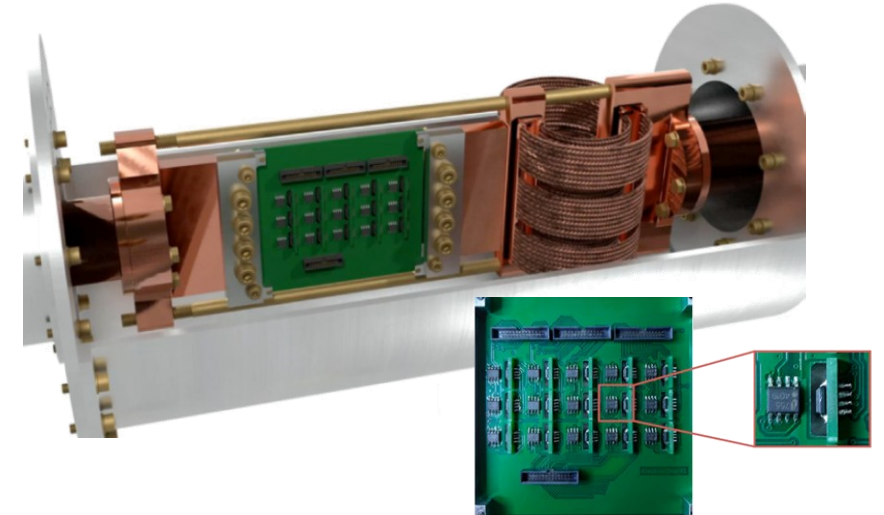

## CRAFT Facility

### Good agreement between simulation and experimental results

- Simulate flux density generated by the current density
- Extract flux density at sensor positions
- Compare to measurement
- Nb/Cu (10 μm) Sample
- Partially superconducting
- Good qualitatively agreement
- Magnitude can change drastically by changing conductivity of the copper

Measurement

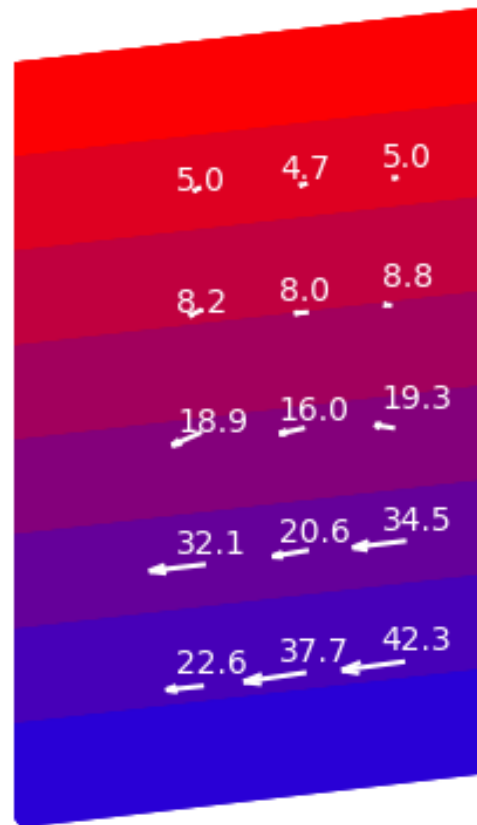

Simulation

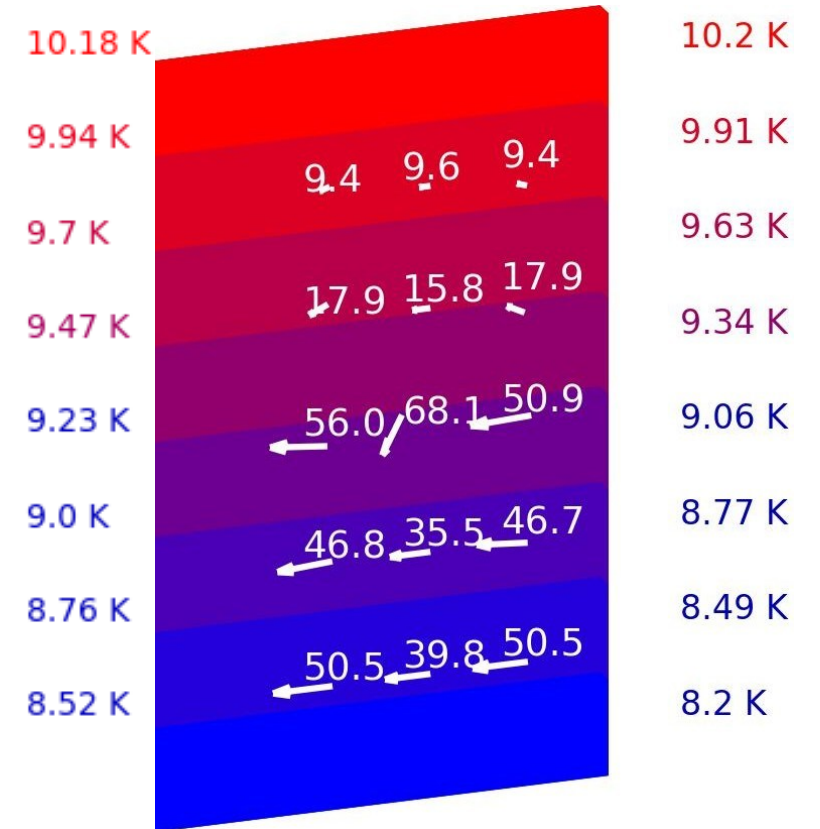

## CRAFT Facility

### TRAPPING EFFICIENCY

- Cool down samples different external fields with constant temperature gradient
- Plot trapped flux versus external field
- Slope of linear fit is trapping efficiency
- **No dependency on temperature gradient**

This is in contrast with bulk samples where the trapping efficiency decreases with increasing temperature gradient

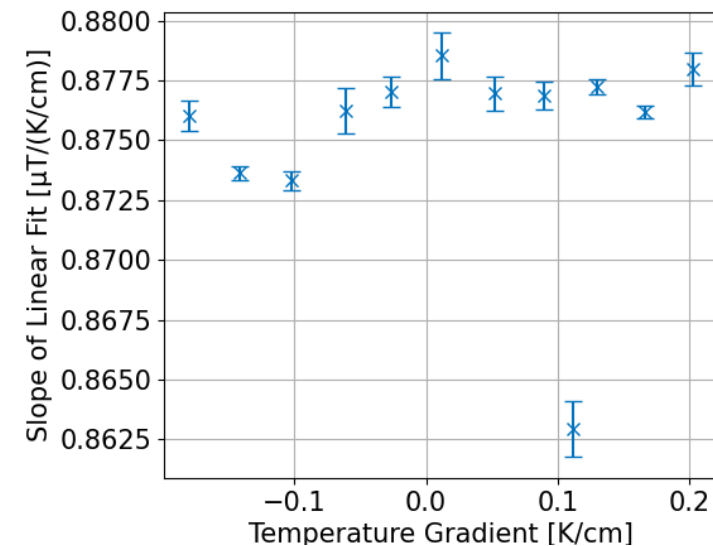
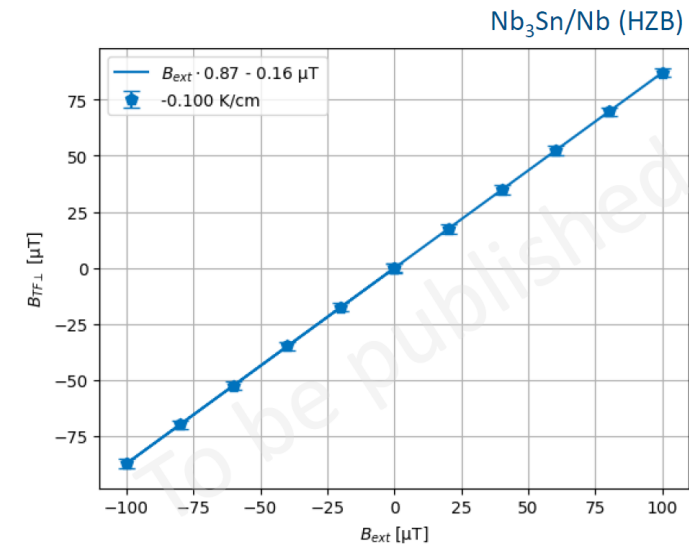

## CRAFT Facility

### Measurement overview

- All Nb<sub>3</sub>Sn samples on copper substrate created large fields during cooldown
- Sample on niobium substrate did not show this behavior
- **Low T<sub>c</sub> Nb<sub>3</sub>Sn samples present Trapped Flux inhomogeneity → non uniform SC phases**

Name	TF Orientation	Uniform T <sub>c</sub>	T <sub>c</sub> [K]
Nb <sub>3</sub> Sn BL (INFN)	inhomogeneous	no	14.7 ± 0.2
Nb <sub>3</sub> Sn (INFN)	inhomogeneous	no	13.2 ± 0.8
Nb <sub>3</sub> Sn/Cu (HZB)	inhomogeneous	no	14.5 ± 0.6
Nb <sub>3</sub> Sn/Nb (HZB)	homogeneous	yes	17.7 ± 0.3
Nb/Cu (10μm)	homogeneous	yes	9.2 ± 0.1
Nb/Cu (4μm)	homogeneous	yes	9.2 ± 0.1

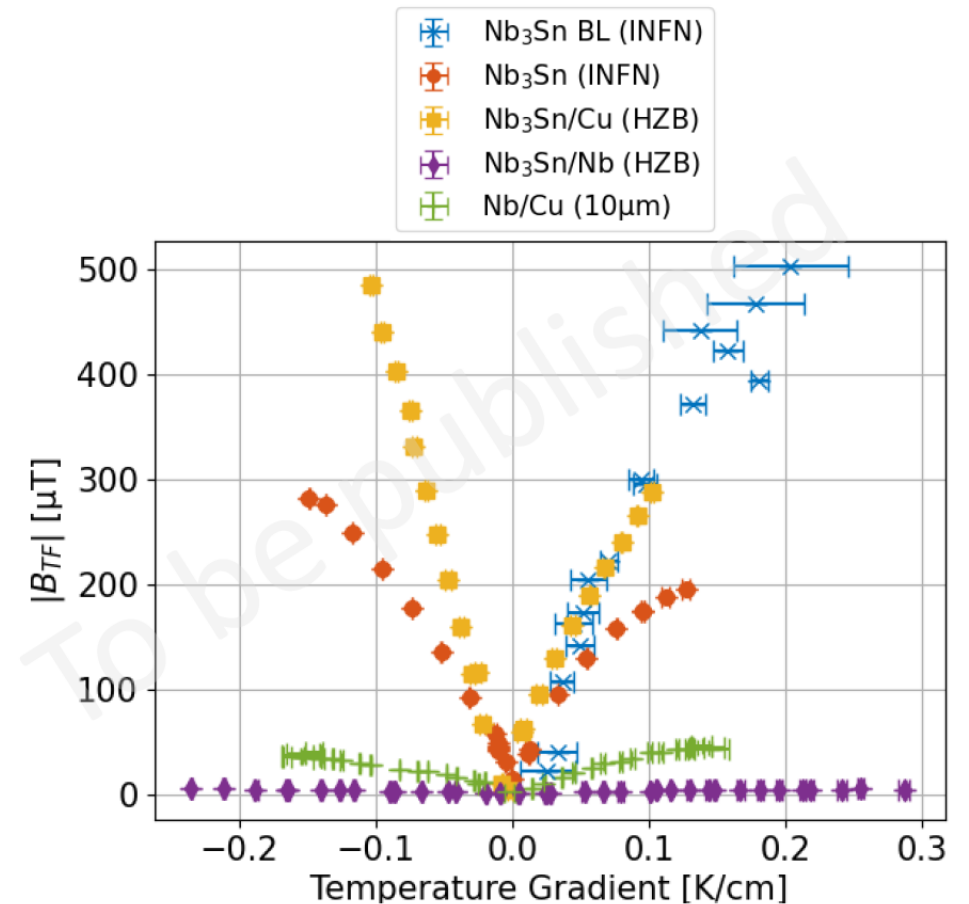

### Next steps

✓ **Milestone 3.1** Modification of choke cavity for flux trapping study - *Engineering report M12* **Completed**

🕒 **Deliverable 3.2** Flux trapping Report on flux dynamics study in Nb<sub>3</sub>Sn on Cu samples - *HZB - Report M30* **On track**

- New samples from INFN and STFC in preparation
- Search for correlation between deposition parameters and the initial penetration field is currently in progress

# RF Tunability (INFN, CEA, HZB, UKRI) – *Oliver Kugeler*

## Objectives

- ▶ Explore new coating parameters on planar samples and small resonators to enhance the mechanical strength in SC A15 films.
- ▶ Mechanical film-stability tests with planar samples.
- ▶ Build cavity tuning system and perform vertical cryo-tests of coated cavities to explore RF performance limits and acceptable tuning without incurring film damage.
- ▶ Devise cavity tuning schemes for Nb<sub>3</sub>Sn cavities fulfilling the required tuning parameters while taking into account the constraints of Nb<sub>3</sub>Sn. The implementation of FE-FRT to assist will be considered.

✓ **Deliverable 3.1** Cavity tuning Report on implementation of cavity Q vs F tuning tool - *HZB - Report M24*

Completed

🕒 **Milestone 3.3** Report on mechanical strength test of SC coatings - *Test report M30*

On track

✓ Deliverable 3.1 Cavity tuning Report on implementation of cavity Q vs F tuning tool

Completed

### Background

- Nb<sub>3</sub>Sn-coated copper cavities must be mechanically tuned to adjust resonant frequency
- Tuning causes deformation that can damage the coating (e.g., cracks, delamination, ageing)
- TESLA-type 1.3 GHz cavities require ~1 MHz tuning range, corresponding to ~2 mm length change ( $\sim 8 \times 10^{-4}$  relative frequency change)
- Coarse tuning is slow (minutes) using a motor-driven lever system with high mechanical advantage
- Cavities also experience fast, small oscillations (0–300 Hz) from piezos for microphonics and compensation
- Deformation is **non-uniform**: local bending, stress concentrations (geometry, welds, tuner contact)
- **A prototype setup with a blade tuner and copper cavity is used to study coating stability under realistic conditions**

## What happen during cavity tuning?

### From Macroscopic to Atomic Scale

Strain translates to:

**picometer-scale lattice changes**

Affects both:

**Substrate (Cu/Nb) & Nb<sub>3</sub>Sn coating**

### Superconducting Consequences

Strain modifies:

**Lattice spacing → electronic structure**

Possible effects:

**Shift in T<sub>c</sub>, Change in critical current, Altered flux pinning**

RF impact:

**Increased surface resistance, Local hot spots at high fields**

### Impact on Nb<sub>3</sub>Sn Coating

Nb<sub>3</sub>Sn is **brittle vs. ductile** substrate

Strain induces:

**Tensile + shear stress, Stress at interface**

Real coatings:

**Grain boundaries, defects → stress concentrators**

Can lead to:

**Microcracks, Delamination, Damage accumulation over cycles**

## Blade Tuner Facility

- Copper prototype cavities provided by **INFN** with **TESLA-shaped geometry**, formed by spinning
- Ends equipped with **horn-shaped „flanges“**  
→ vacuum-tight via CF-100 adapters
- Permanent vacuum connections (not removed after assembly)
- **Blade tuner design:**
- Three concentric rings along cavity axis  
→ connected via **titanium blades (spring elements)**
- Middle ring split  
→ converted into **axial cavity deformation**
- Lateral motion  
→ converted into **axial cavity deformation**
- Challenge: Standard tuners attach to **LHe tank**, not bare cavity, to be used in bath cryostat
- Solution: Custom **groove + adapters (HZB)** to connect tuner directly to cavity

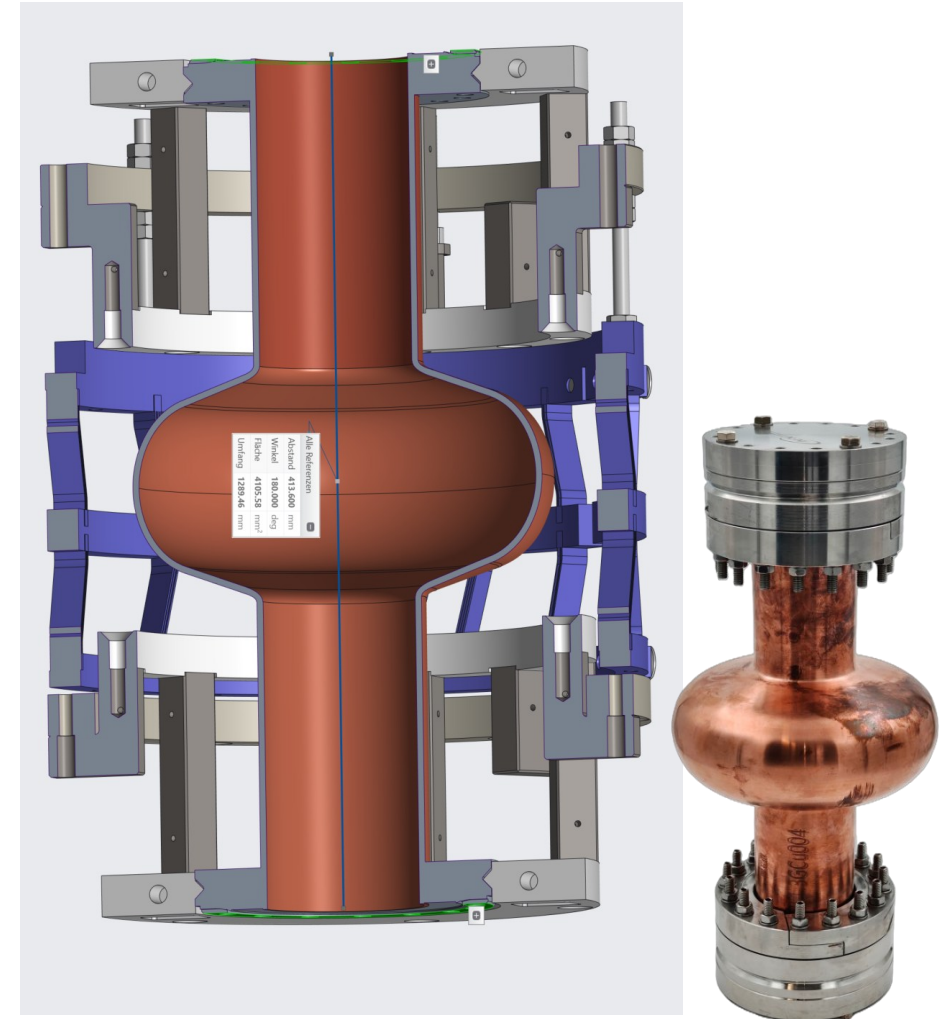

## Blade Tuner Facility

### Actuation & RF Measurement

- **Stepper motor (Phyton) + harmonic drive**  
→ precise, reproducible cavity length control
- Two antennas:
  - One **strongly coupled**
  - One **weakly coupled**
- **Vector Network Analyzer (VNA):**
- Measures S-parameters  
→ resonance frequency & bandwidth
- Automated via **Python GUI (ChatGPT-assisted)**

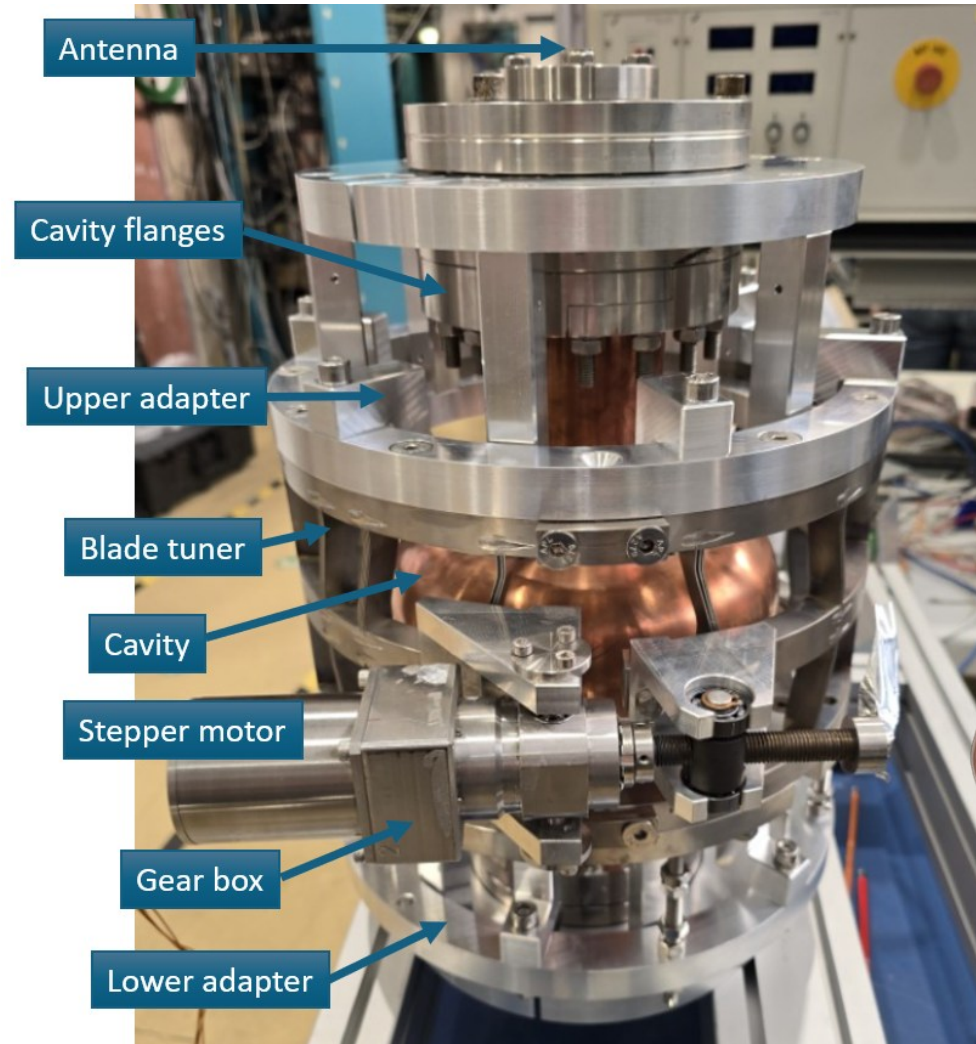

## Blade Tuner Facility

### Prompt engineered DAQ tool

1000 lines of python code entirely generated by AI

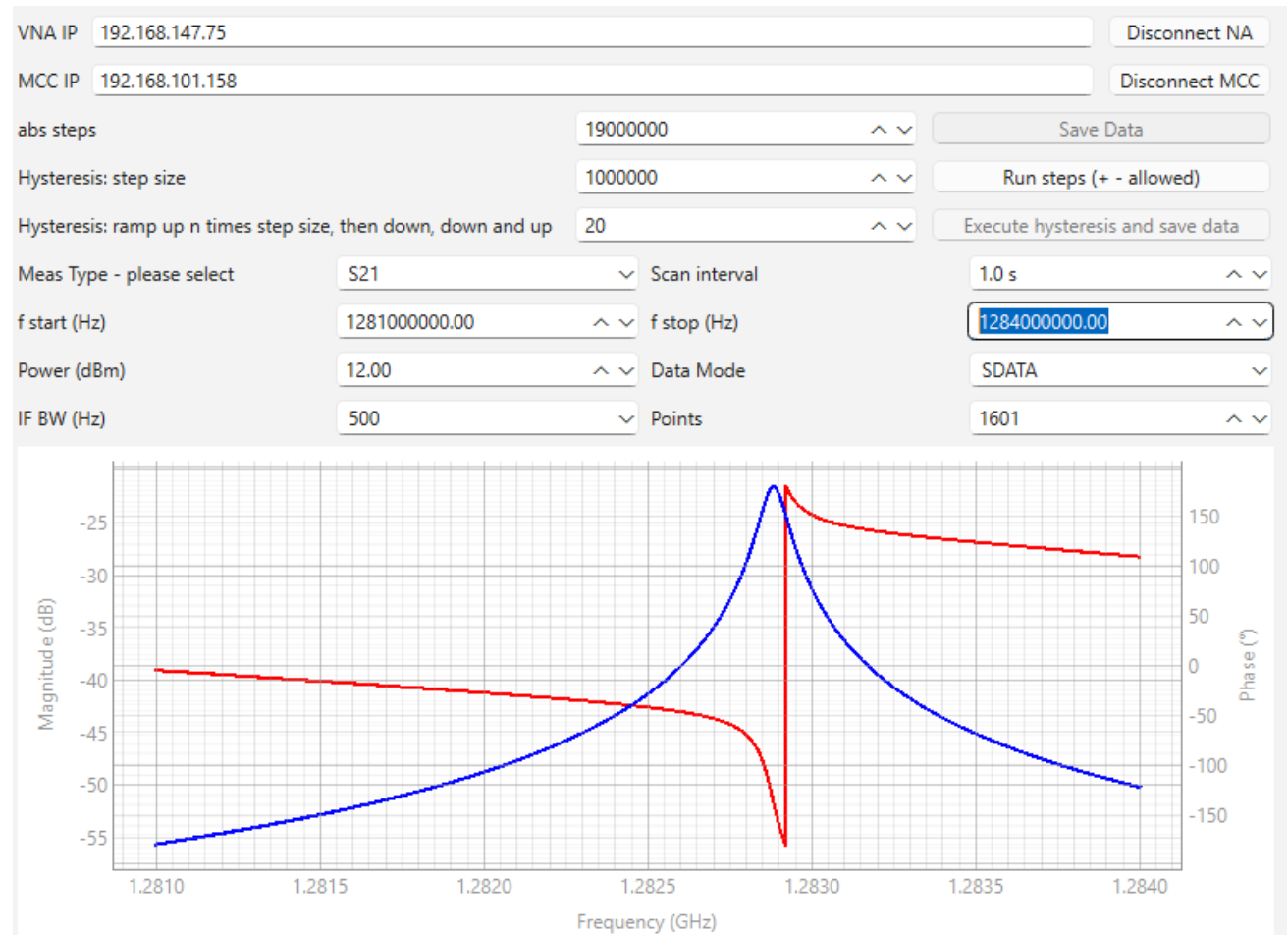

## Blade Tuner Facility

### Results:

- Range ok
- Linearity ok
- Small hysteresis
- Small plastic deformation at >1MHz elongation (can be healed)

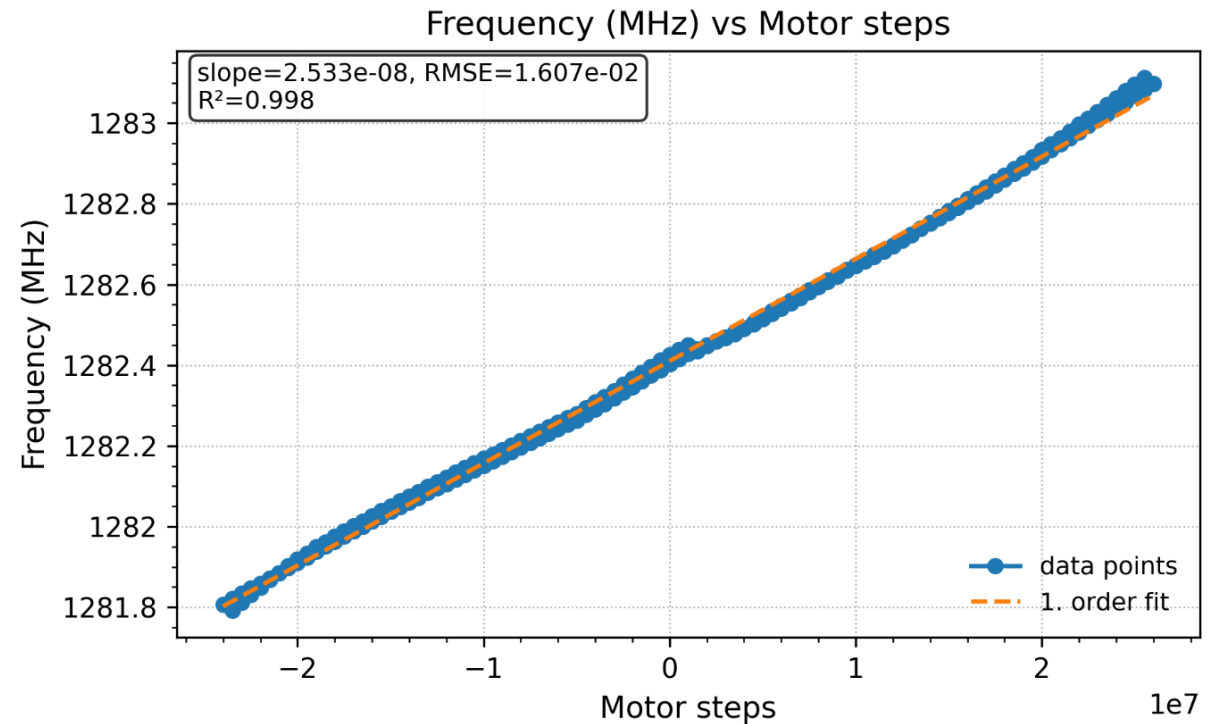

🕒 Milestone 3.3 Report on mechanical strength test of SC coatings - *Test report M30*

On track

## Mechanical Strength Test on Planar Samples

### 4 Probe T<sub>c</sub> measurement during sample elongation

- Design of traction test Cu C2 (OFHC) samples were elaborated at **CEA** and sent for production
- The Cu traction samples will be electropolished, half will be coated by ALD and sent to **INFN** and **UKRI** for Nb<sub>3</sub>Sn/Nb deposition

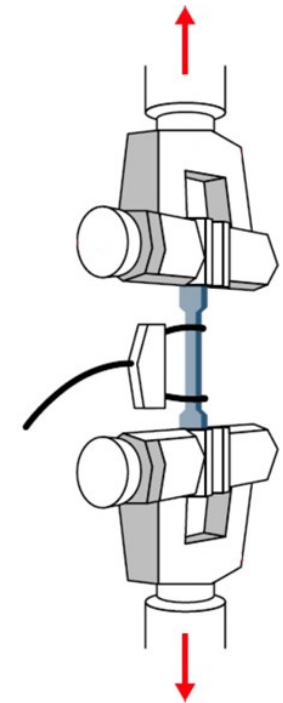
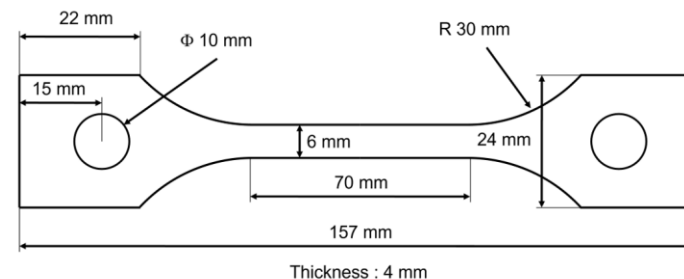

### Next steps

✓ **Deliverable 3.1** Cavity tuning Report on implementation of cavity Q vs F tuning tool - *HZB - Report M24*

Completed

- Confirm vacuum tightness upon tuning
- Use better antenna
- Operate with Nb<sub>3</sub>Sn coated cavity in bath cryostat (above lambda point)
- Optional: equip HRD (movable antenna tool)

🕒 **Milestone 3.3** Report on mechanical strength test of SC coatings - *Test report M30*

On track

- The Cu traction samples will be electropolished, half will be coated by ALD and sent to **INFN** and **UKRI** for Nb<sub>3</sub>Sn/Nb deposition

## Adaptive Layers (INFN, CEA, HZB, UKRI) – *Thomas Proslie*

### Objectives

- ▶ Develop adaptative layers by atomic layer deposition on Cu that are stable up to 650 °C.  
*Insulating oxides layer: Al<sub>2</sub>O<sub>3</sub>, ZrO<sub>2</sub>, ZrAlO<sub>x</sub> as diffusion barriers*
- ▶ Compare performance Nb<sub>3</sub>Sn on Cu with and without adaptive layers on planar samples and QPR.

✓ **Deliverable 3.3** Adaptive Layer Report on QPR study of Nb<sub>3</sub>Sn on Cu & adaptive layers - *CEA - Report M38*

On track

🕒 **Milestone 3.2** Developed ALD adaptive layers on Cu - *Test report M24*

Completed

✓ Milestone 3.2 Developed ALD adaptive layers on Cu - M24 **Completed**

## MAIN RESULTS ACHIEVED

Developed several insulating ALD layers:  
Al<sub>2</sub>O<sub>3</sub>; ZrO<sub>2</sub>, AlZrO<sub>x</sub>, bilayers Al<sub>2</sub>O<sub>3</sub> - ZrO<sub>2</sub>

- stable up to 700°C for 2 hrs in high vacuum  
(Nb/Nb<sub>3</sub>Sn deposition conditions)
- High Pressure Rinsing (HPR) test passed

Studied the influence of the film structure and chemical composition on the superconducting film growth

- The presence of an **ALD Al<sub>2</sub>O<sub>3</sub> layer does not affect the structural and superconducting properties** of Nb films deposited on top (XRD, Tunneling spectroscopy, TEM).

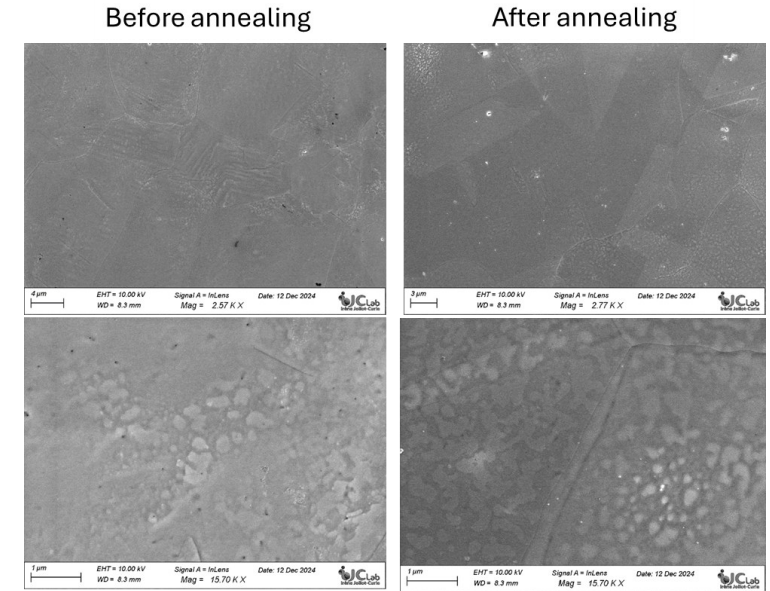

## FIRST IMPLEMENTATIONS

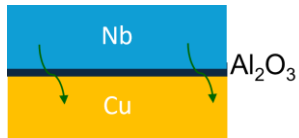

Coated a 1.3 GHz Cu cavity (deposition system built in IFAST) from **CERN** with 20 nm thick Al<sub>2</sub>O<sub>3</sub> layer – sent back to CERN for **Nb deposition by HiPIMS**  
→ *problem of Nb delamination after HPR*

Coated EP Cu samples from **INFN-LNL** with several oxide ALD layers alloys sent back to INFN for Nb and **Nb<sub>3</sub>Sn deposition**

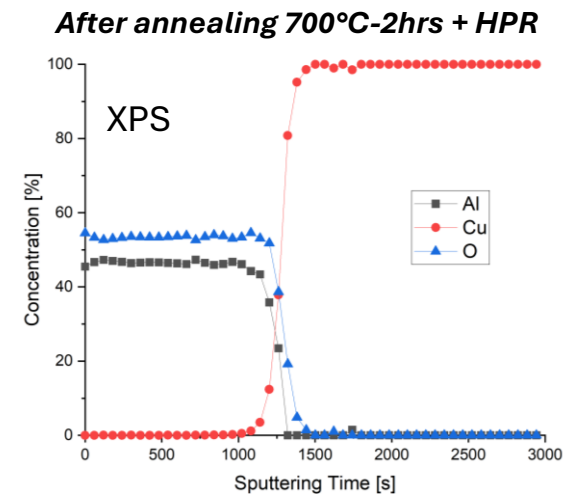

🕒 **Deliverable 3.3** Adaptive Layer Report on QPR study of Nb<sub>3</sub>Sn on Cu & adaptive layers - *M38*

**On track**

## Current developments (1)

- **Coated a second 1.3 GHz Cu cavity from CERN** with modified deposition parameters with 20 nm thick ALD layers -> sent back to CERN for Nb deposition by HiPIMS
- **No delamination after HPR**
- **RF test showed a ten time reduction in thermo-currents intensities !**
- Exploring the thickness dependence of the ALD interface layer on the thermo-current suppression capabilities and RF tests performances.

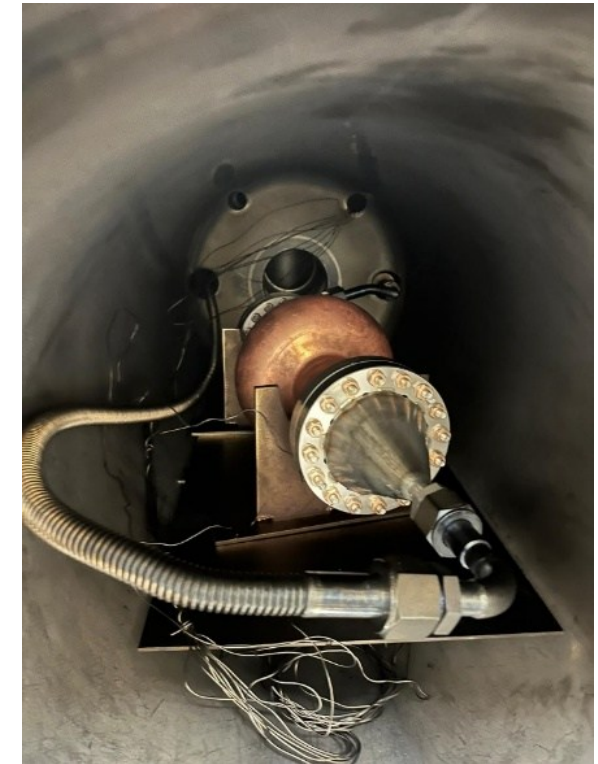

**Deliverable 3.3** Adaptive Layer Report on QPR study of Nb<sub>3</sub>Sn on Cu & adaptive layers - *M38*

**On track**

## Current developments (2)

- Deposition of Nb and Nb<sub>3</sub>Sn at INFN-LNL on ALD coated Cu coupons
- Transport measurements done at INFN-LNL showed that the **T<sub>c</sub> (~ 16 K) is not affected by the presence of a ~ 20-25 nm thick ALD layer**. Further characterization is underway.
- Other EP Cu and EP Cu with Nb coatings sent to CEA for ALD coating. *In progress*
- R&D on planar coupons evaluating different configurations:

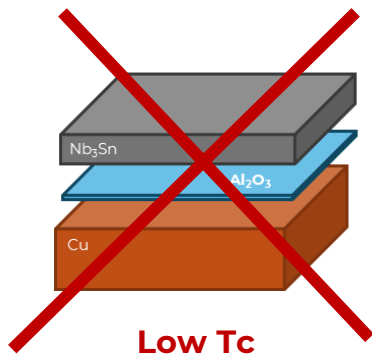
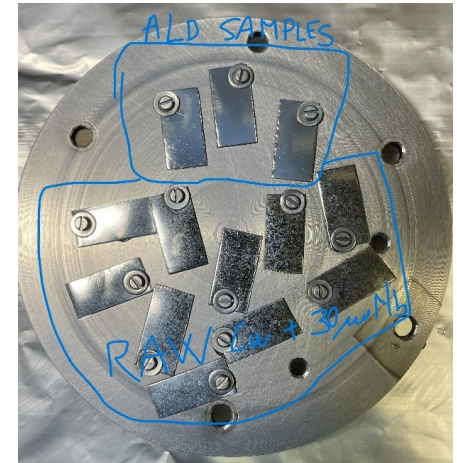

Low T<sub>c</sub>

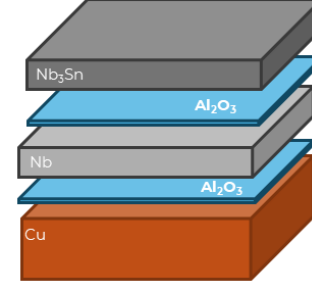
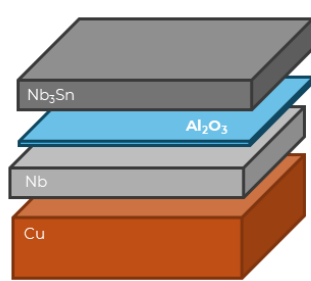
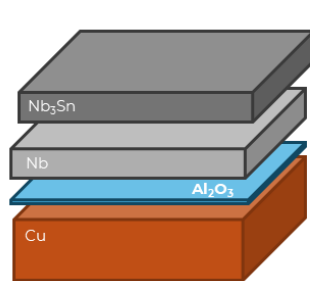

T<sub>c</sub> ~ 17 K

Buffer Layer	T <sub>c</sub>	ΔT <sub>c</sub>
No buffer layer	13.8 K	0.3 K
16 μm Nb	16.5 K	0.6 K
30 μm Nb	16.7 K	0.5 K
<b>30 μm Nb + 18 nm Al<sub>2</sub>O<sub>3</sub></b>	<b>16.3 K</b>	<b>0.5 K</b>
<b>30 μm Nb + 25 nm AlZrO<sub>x</sub></b>	<b>16.9 K</b>	<b>0.2 K</b>
<b>30 μm Nb + 5 nm Al<sub>2</sub>O<sub>3</sub> + 22 nm ZrO<sub>2</sub></b>	<b>16.8 K</b>	<b>0.2 K</b>

## Next steps

✓ **Milestone 3.2** Developed ALD adaptive layers on Cu - *M24* **Completed**

🕒 **Deliverable 3.3** Adaptive Layer Report on QPR study of Nb<sub>3</sub>Sn on Cu & adaptive layers - *M38* **On track**

- Continue R&D on planar coupons trying different configurations
- Coat and test QPR with optimized configuration

## Working Cavity (INFN, CEA, HZB, **UKRI**) – *Reza Valizadeh*

### Objectives

- ▶ Improve I.FAST 1.3-GHz superconducting coating recipe based on Tasks 3.2-3.4 results.
- ▶ Prepare 1.3-GHz thin film cavities with an optimized coating recipe.
- ▶ Perform full cavity characterization @4.2 K (Q vs E, Q vs F, and flux trapping in the VTS@SupraLab vertical test stand).

🕒 **Deliverable 3.4** 4.5-K Cavity Report on 4.5-K Cavity performance & tunability tests - INFN - *Report M46* **On track**

🕒 **Milestone 3.4** Characterization of Nb<sub>3</sub>Sn reference cavity - *Test report M34* **On track**

## Optimized coating recipe

1. Low cathode Power  
≤ 250 mW/cm<sup>2</sup>
- +
2. High deposition Pressure:  
2 x 10<sup>-2</sup> mbar
- +
3. Deposition Temperature:  
600 °C – 650 °C
- +
4. No post Annealing
- +
5. Nb buffer layer ≥ 30 μm

**T<sub>c</sub> > 17 K**

**scientific reports**

OPEN [Recipe optimization and SRF test of Cu-compatible Nb<sub>3</sub>Sn films by DC magnetron sputtering from a stoichiometric target](#)

D. Fomesu<sup>1,2</sup>, D. Ford<sup>1</sup>, E. Chyhyrynets<sup>1</sup>, S. Keckert<sup>2</sup>, J. Knobloch<sup>2,3</sup>, O. Kugeler<sup>2</sup>, M. Lazzari<sup>1</sup>, G. Marconato<sup>1</sup>, A. Salmasso<sup>1</sup>, A. Zubtsovskii<sup>1</sup> & C. Pira<sup>1</sup>

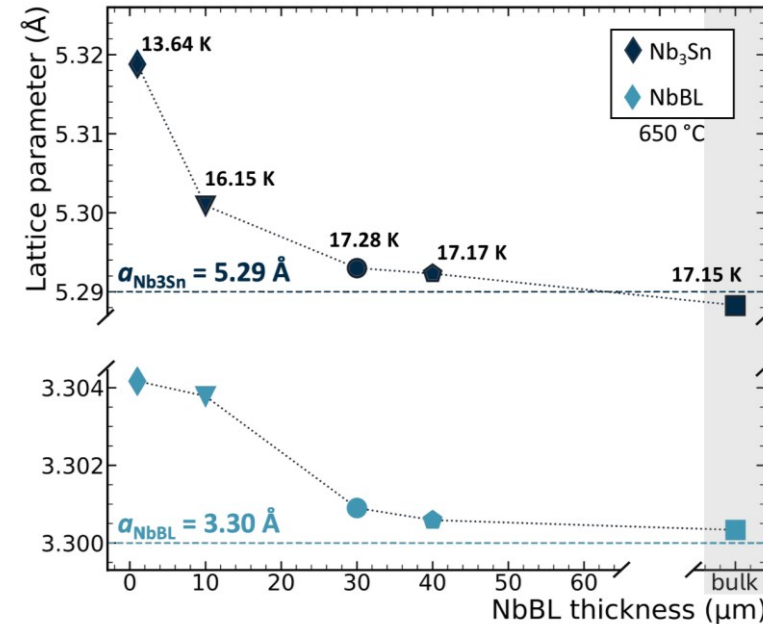

**Barrier Layer against Sn and Cu diffusion**

**Accommodation layer (release thermal stress)**

## RF Test on QPR (*recipe validation*)

### Sample #2 on Nb<sub>3</sub>Sn on Nb bulk (State of the art)

- $T_c = 17.45$  K
- Quench > 85 mT extrapolated @ 0 K
- $R_s < 9$  n $\Omega$  @ 4 K, 20 mT
- Better than VTD sample up to 50 mT

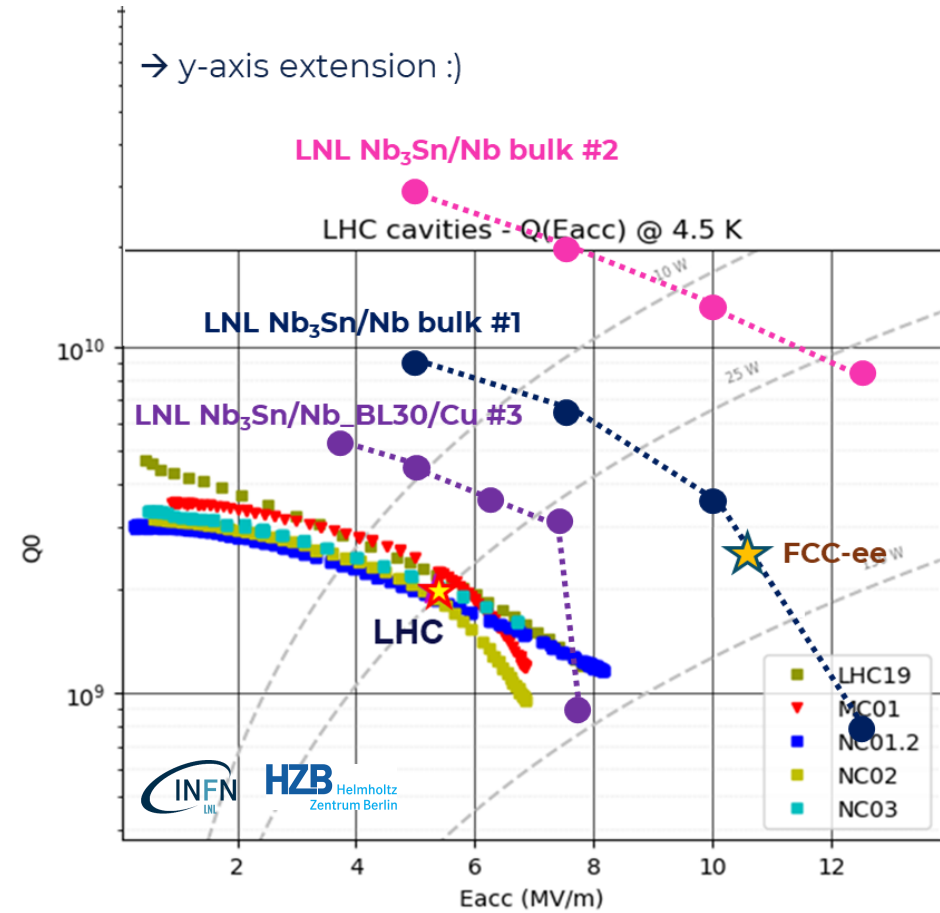
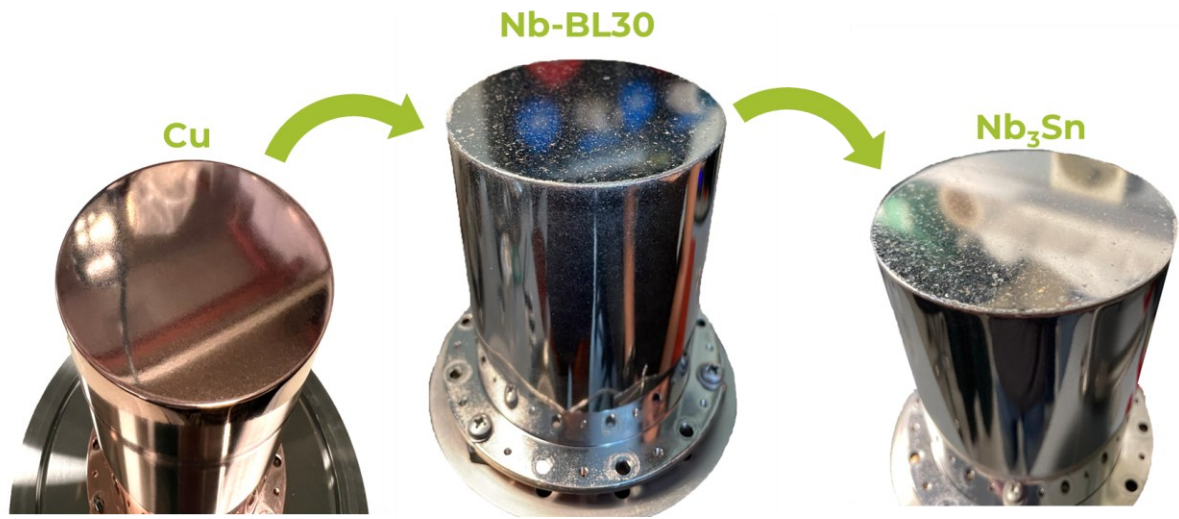

**Q value 10 times > LHC!**

## 2 Different 1.3 GHz coating system ready (testing phase)



Rectangular magnetron  
Rotating Cavity

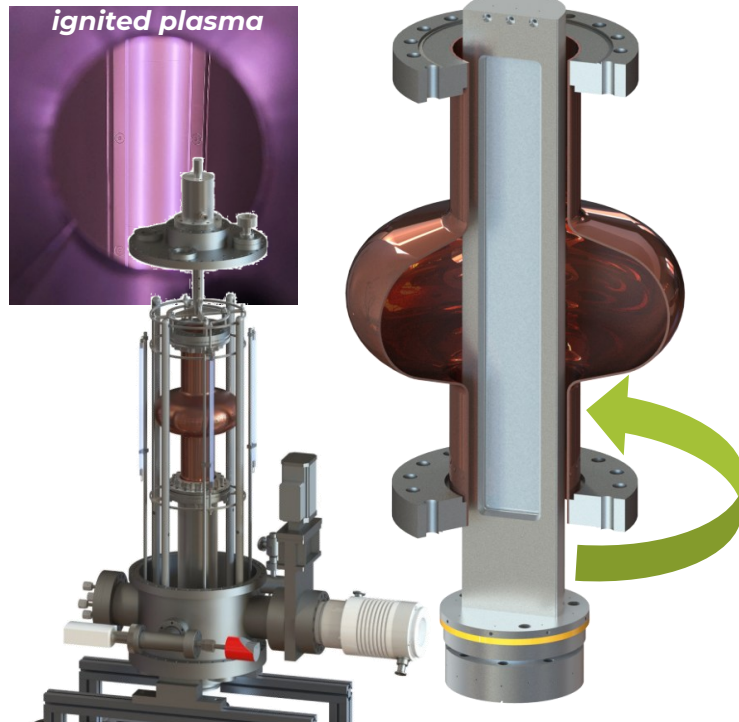

[M. Lazzari et al., "Development of a new system for Nb<sub>3</sub>Sn thin film deposition on 1.3 GHz cavities", in Proc. SRF2025, Tokyo, doi:10.18429/JACoW-SRF2025-TUP31](#)



Double movable magnetrons  
Fixed cavity

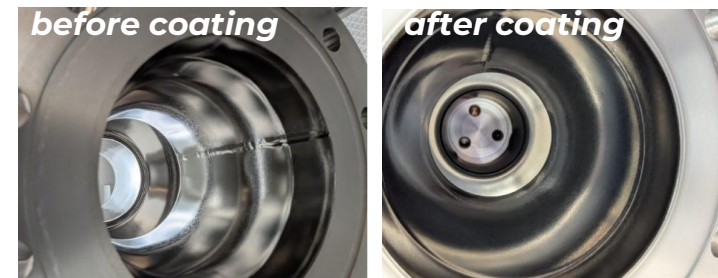
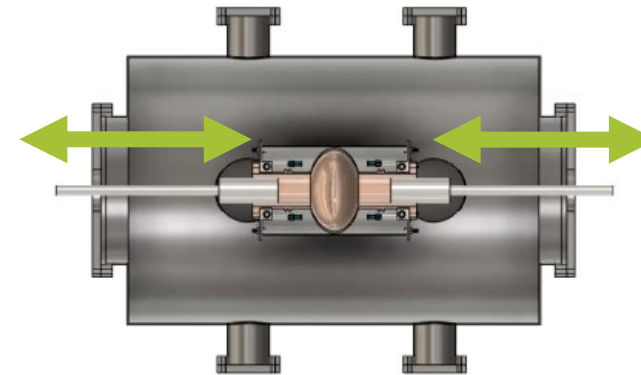

[N. Leicester et al., "Development of a 1.3 GHz longitudinally split RF research cavity for use in testing of superconducting thin films", in Proc. SRF2025, Tokyo, doi:10.18429/JACoW-SRF2025-TUP19](#)

# 1.3 GHz coating system @ LNL

Custom fixed rectangular planar magnetron with **rotating cavity system**

## Current Status:

- **vacuum system** assembled and tested
- **heating system** completed and tested
- **magnetron test** ongoing
- **first Nb cavity coating** planned for late 2026
- **Coating on Cu cavity** planned for 2027

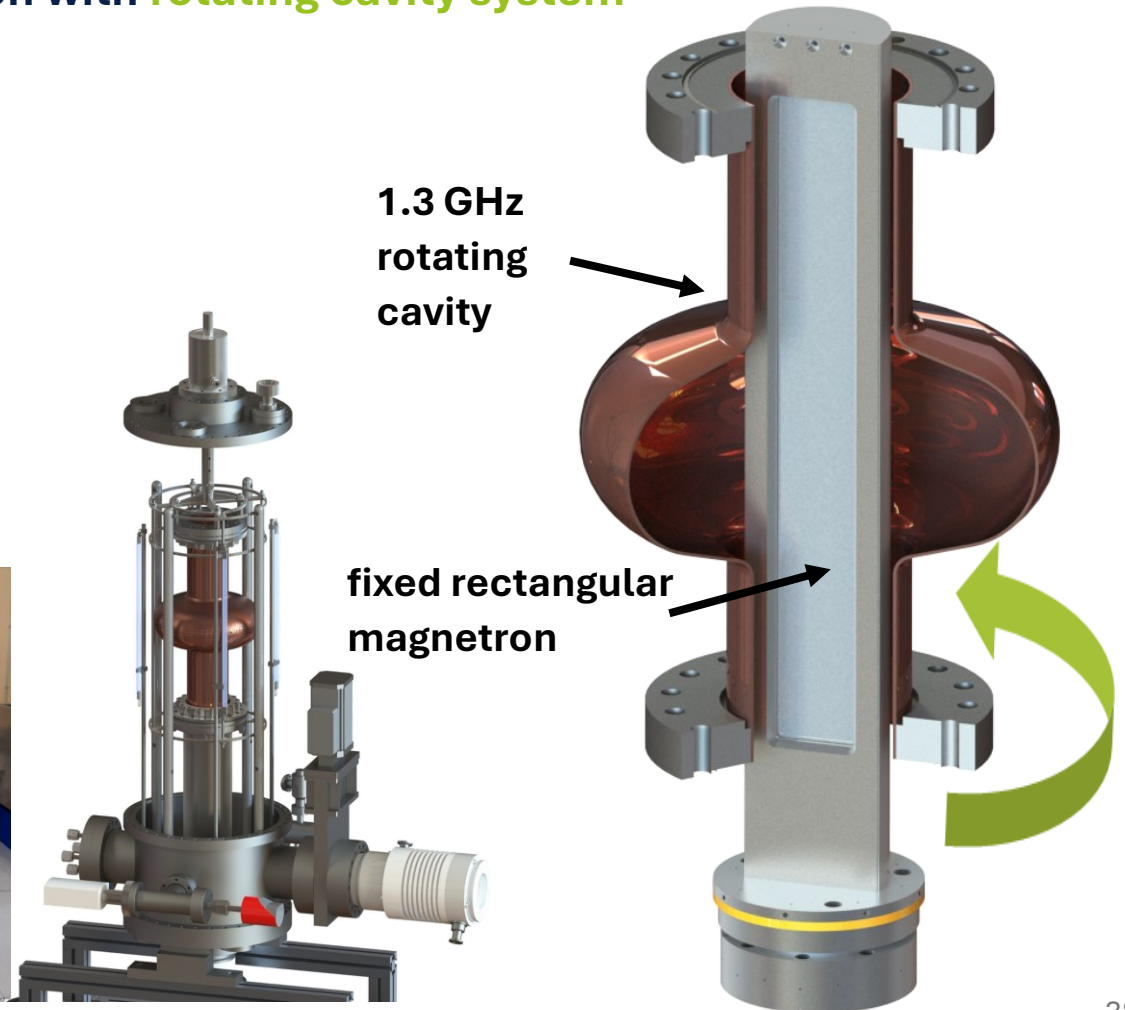
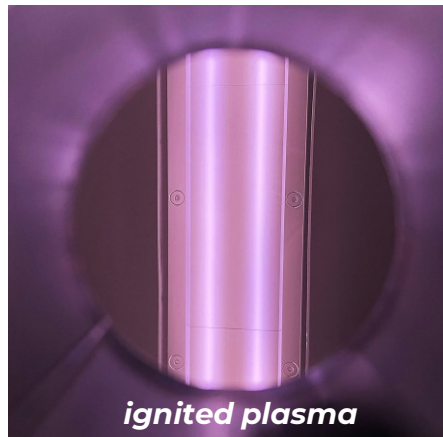

# 1.3 GHz coating system

Custom fixed rectangular planar magnetron with **rotating cavity system**

## Rectangular Magnetron

- Test with Nb target
- 3 sets of magnets to be tested (0.68 T, 0.92 T, 1.02 T)
- Tested 0,92T and 1.02 T configuration up to 1 A

→ classical power law obtained

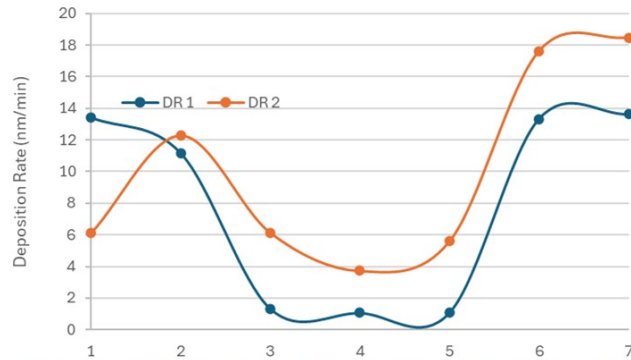

$$DR2_{equator} \sim 4 \times DR1_{equator}$$

$$DR1_{equator} / = DR1_{cut-off} \sim 13$$

$$DR2_{equator} / = DR2_{cut-off} \sim 5$$

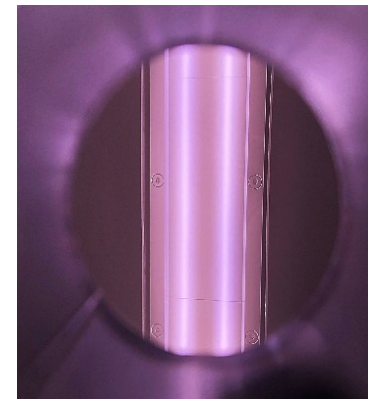
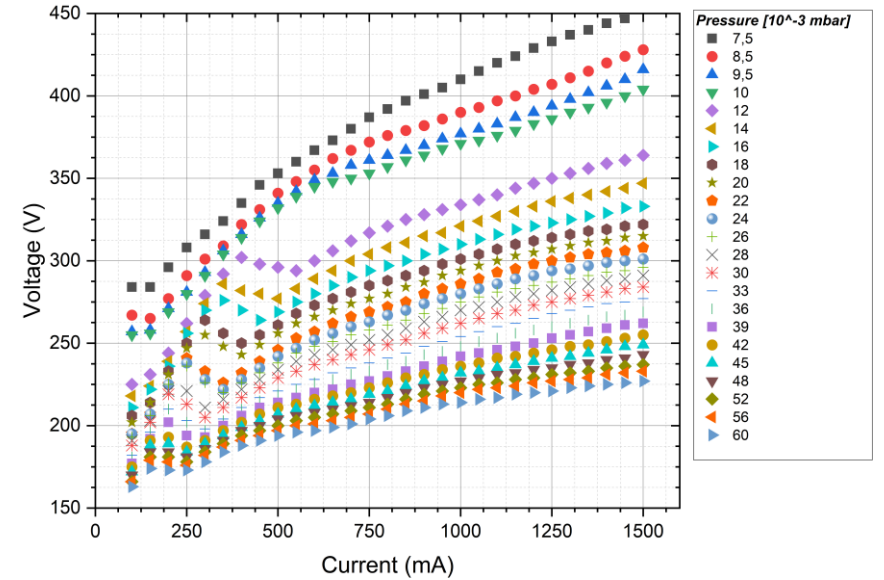

## First Cavity Coated @UKRI

### Nb<sub>3</sub>Sn on Nb bulk (reference cavity)

- Tested at HZB
- No HPR after Deposition
- Fixed RF couplers (designed for Q<sub>o</sub> of 10<sup>9</sup>)
- Manually slow cool Down
- No thermo-currents were recorded with the azimuthally placed sensors.
- **T<sub>c</sub> = 18.1 K**
- No T<sub>c</sub> of Nb was detected: Possibly cavity fully coated
- RF surface resistance of 8 x 10<sup>6</sup>
- **Poor Q factor:**
  - Cu contamination at surface layer due to diminishing target
  - Present of other normal conducting material due to poor cavity handling.
  - Or other reasons to be determined.

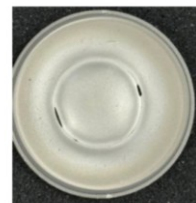
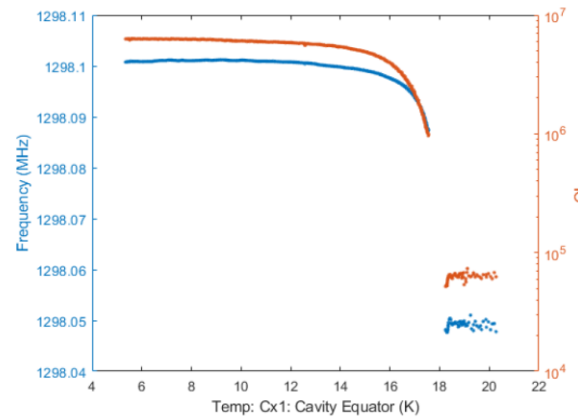
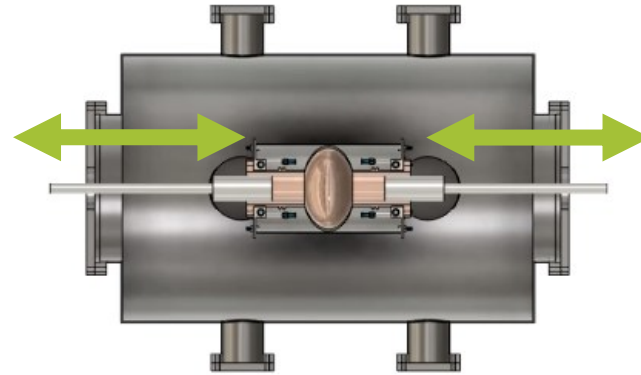

After target removed

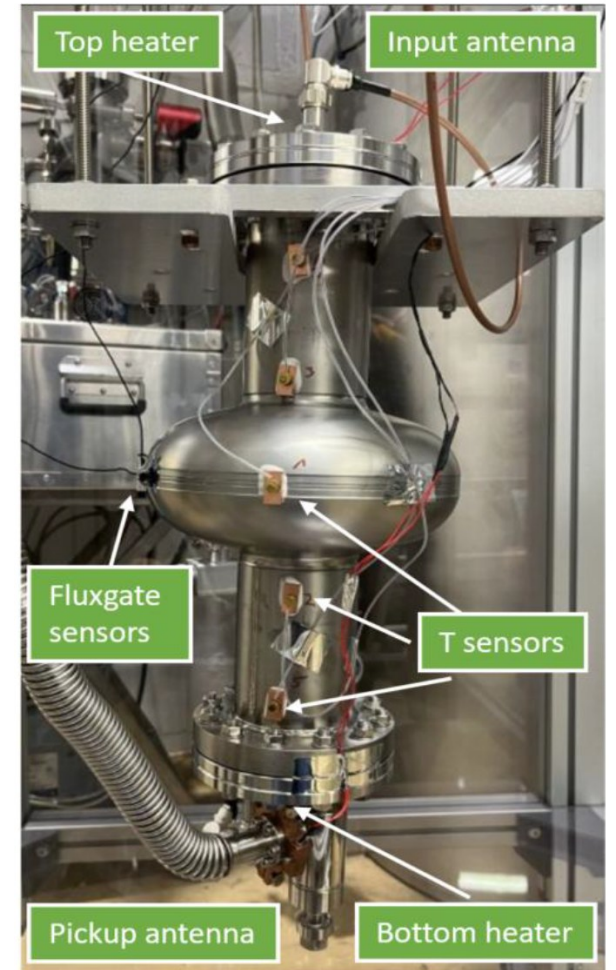

# 1.3 GHz coating system @ STFC

Double movable magnetrons with **fixed cavity**

## Current Status:

- Chamber already mounted
- Manipulators for each magnetron are delivered and mounted
- Few modification is on the way before full assembling

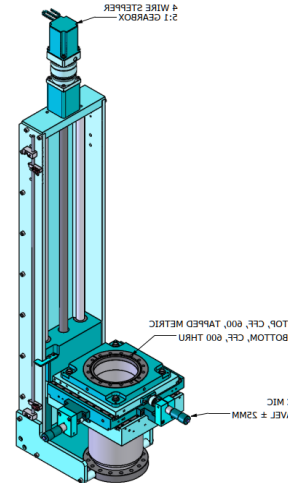
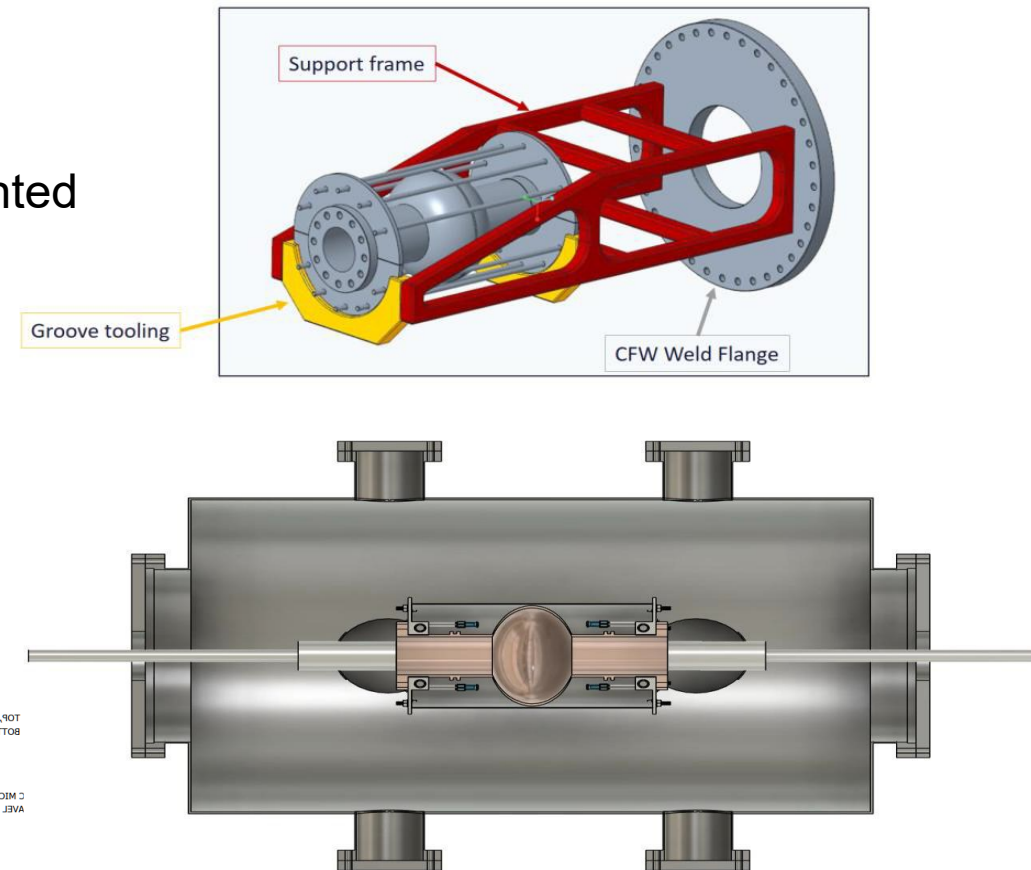
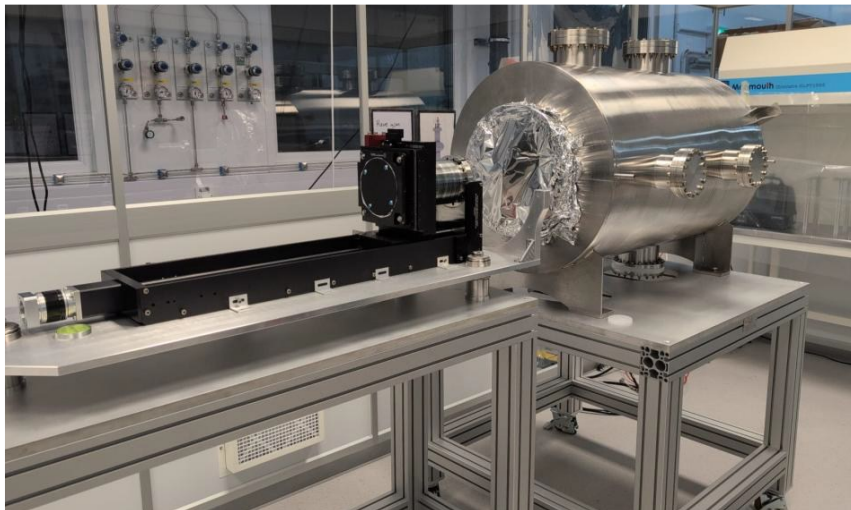

# Deposition of Nb on Cu cavity

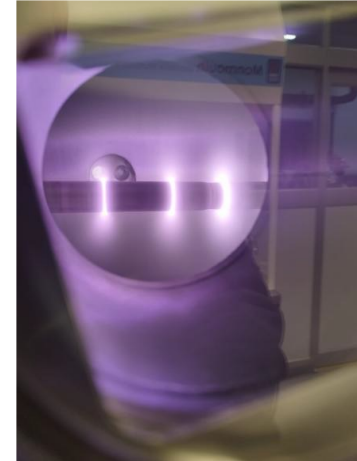
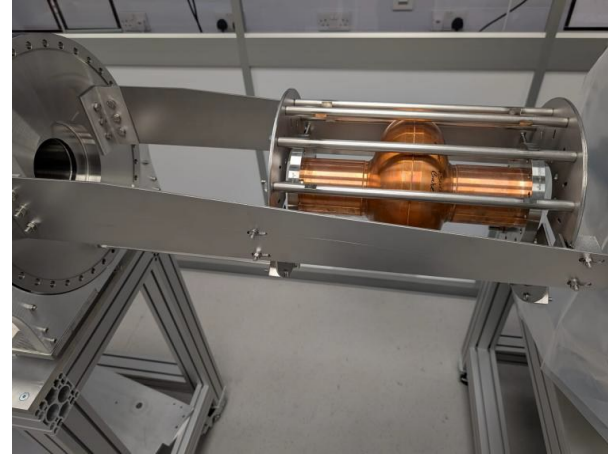
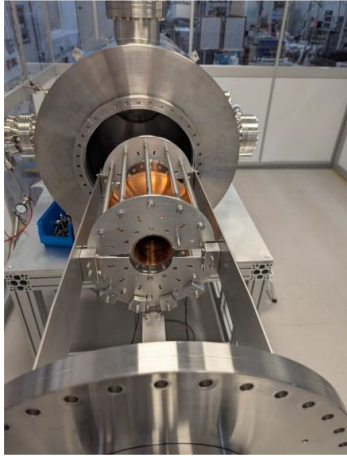

## PROGRAM

1. Optimisation and design of deposition facilities
2. Nb deposition on copper cavity soon
3. 1.3 GHz Nb<sub>3</sub>Sn cavity prototyped by PVD using Nb cavity as substrate

A few problems keep persisting at STFC and delaying the progress:

- In-house surface polishing & HPR
- Cylindrical target for Nb<sub>3</sub>Sn (may be)

## Next Steps

1. Characterize the Reference Cavity with Blade Tuner and flux trapping probe @HZB to complete milestone 3.4 (M34)
2. Continue test on coupons to optimize SC film quality along the cavity and and ensure performance reproducibility
3. Coating Nb<sub>3</sub>Sn on Bulk Nb cavity first + RF test
4. Coating Nb<sub>3</sub>Sn on Cu cavity + RF test (deliverable 3.4, M46)

# WP3 Nb<sub>3</sub>Sn on Cu: plans to achieve milestones & deliverables

Milestones & deliverables  
**on track**

- ✓ M3.1 Modification of choke cavity for flux trapping study - *Engineering report M12*
- ✓ M3.2 Developed ALD adaptive layers on Cu - *Engineering report M24*
- ✓ M39 Impact risk analysis WP3 – *Presentation/report M24*
- ⌚ M3.3 Report on mechanical strength test of SC coatings - *Test report M30*
- ⌚ M3.4 Characterization of Nb<sub>3</sub>Sn reference cavity - *Test report M34*

- ✓ D3.1 Cavity tuning Report on implementation of cavity Q vs F tuning tool - *Report M24 - HZB*
- ⌚ D3.2 Flux trapping Report on flux dynamics study in Nb<sub>3</sub>Sn on Cu samples - *Report M30 - HZB*
- ⌚ D3.3 Adapt. Layer Report on QPR study of Nb<sub>3</sub>Sn on Cu & adaptive layers - *Report M38 - CEA*
- ⌚ D3.4 4.5-K Cavity Report on 4.5-K Cavity performance & tunability tests - *Report M46 - INFN*

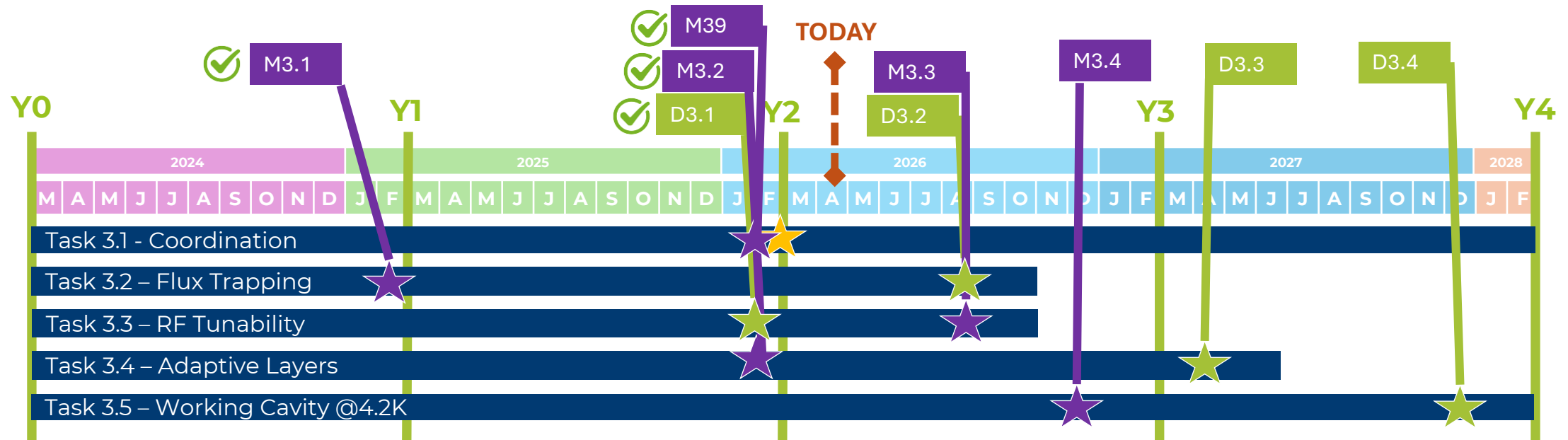

## Advanced characterization facilities

(task 3.2 and 3.3)

### Flux trapping

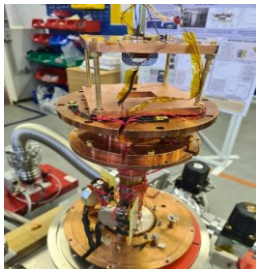

Choke cavity and field penetration facility upgrade done



CRAFT Facility built and tested



Milestone 3.1 completed

### Tunability

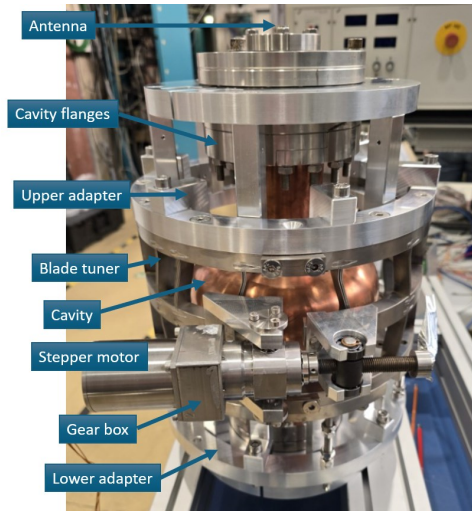

Blade Tuner built and tested



Deliverable 3.1 completed

## Adaptive layers

(task 3.4)

Al<sub>2</sub>O<sub>3</sub>, ZrO<sub>2</sub> and AlZrO<sub>x</sub> oxides successfully coated by ALD and stable up to 750 °C

Mitigation of thermo-electric currents proved on Nb

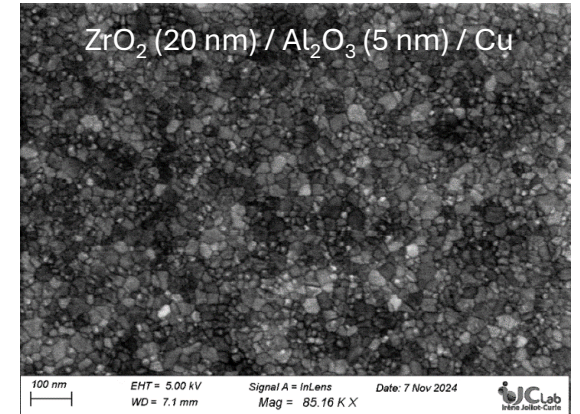

Milestone 3.2 completed

(task 3.5)

**Coating recipe optimized and validated on small planar resonator (QPR)**

**Q value 10 times > LHC!**

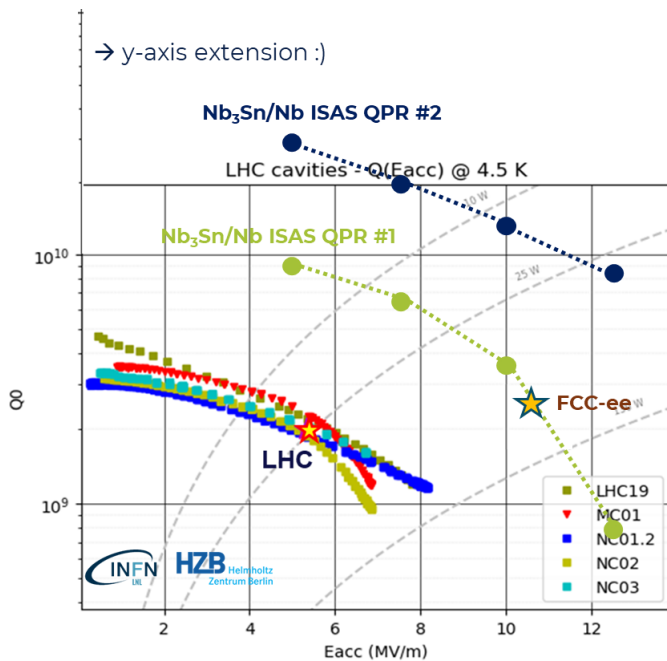

D. Fonnesu et al., "Recipe optimization and SRF test of Cu-compatible Nb<sub>3</sub>Sn films by DC magnetron sputtering from a stoichiometric target. Sci Rep 16, 3539 (2026)

**2 Different 1.3 GHz coating system ready (testing phase)** (task 3.5)



Rectangular magnetron  
Rotating Cavity



Double movable magnetrons  
Fixed cavity

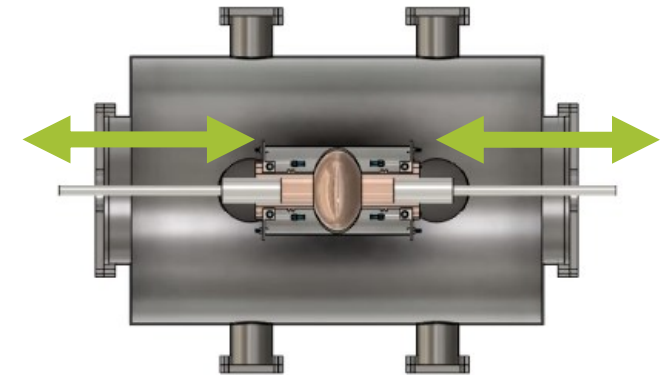

M. Lazzari et al., "Development of a new system for Nb<sub>3</sub>Sn thin film deposition on 1.3 GHz cavities", in Proc. SRF2025, Tokyo, doi:10.18429/JACoW-SRF2025-TUP31

N. Leicester et al., "Development of a 1.3 GHz longitudinally split RF research cavity for use in testing of superconducting thin films", in Proc. SRF2025, Tokyo, doi:10.18429/JACoW-SRF2025-TUP19

### Conclusion

- Milestone and deliverables on track
- During Period 1, the individual components of the puzzle were produced (*coating facilities, characterization facilities, optimized coating recipes, ...*)
- During Period 2, these pieces will be combined to produce the 1.3 GHz cavity





**Thank You!**