



Science and  
Technology  
Facilities Council

# STFC Thin Films Cavity production Program

Reza Valizadeh  
on behalf of STFC Thin Film Group

# RF Test At HZB

- No HPR after Deposition
- The RF couplers were designed for  $Q_0$  of  $10^9$
- Manually slow cool Down
- No thermo-currents were recorded with the azimuthally placed sensors.
- While the  $T_c$  was at 18.1 K this did not help with the RF surface resistance of  $8 \times 10^6$
- No  $T_c$  of Nb was detected: Possibly cavity fully coated.
- Poor Q factor:
  - Cu contamination at surface layer due to diminishing target
  - Present of other normal conducting material due to poor cavity handling.
  - Or other reasons to be determined.

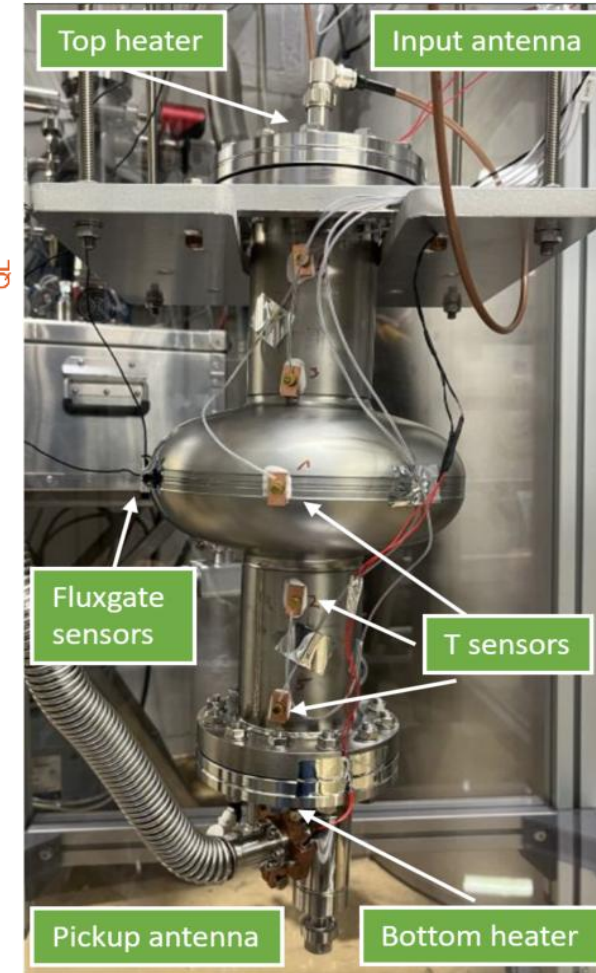
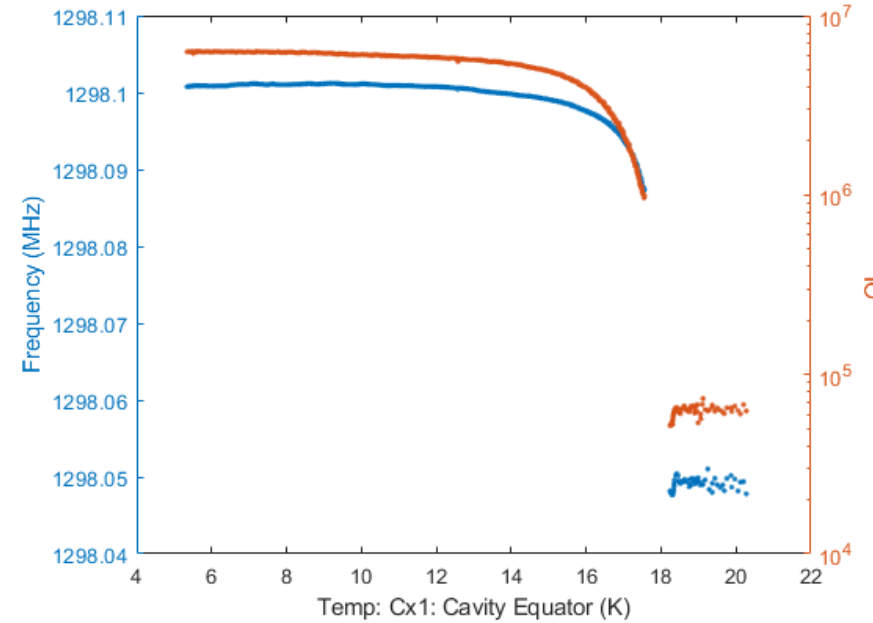

Just after venting chamber



After target removed

# Nb Disk deposition inside segmented Nb Cavity C

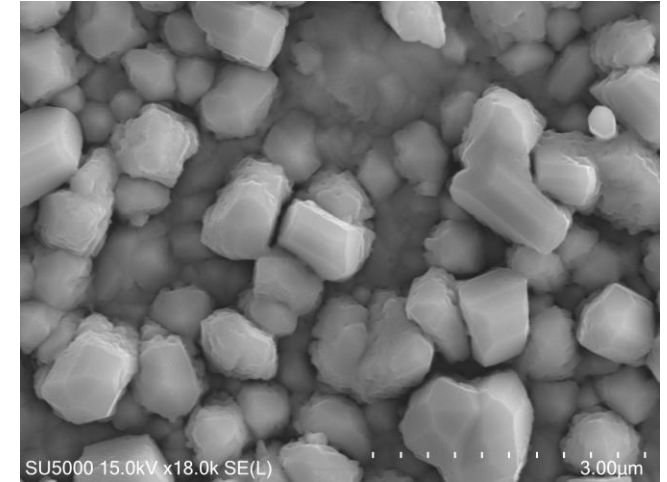
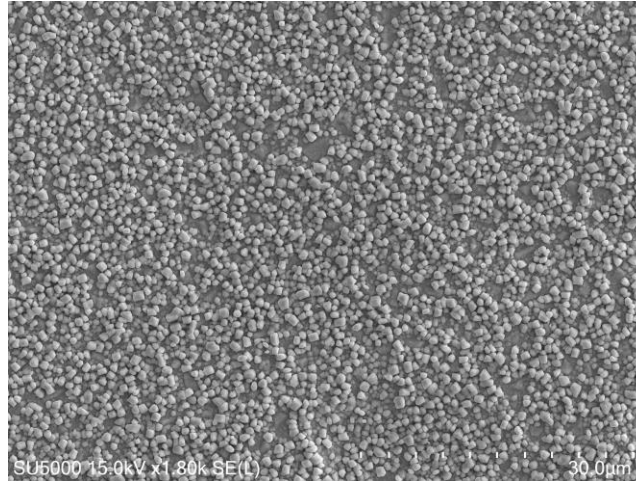
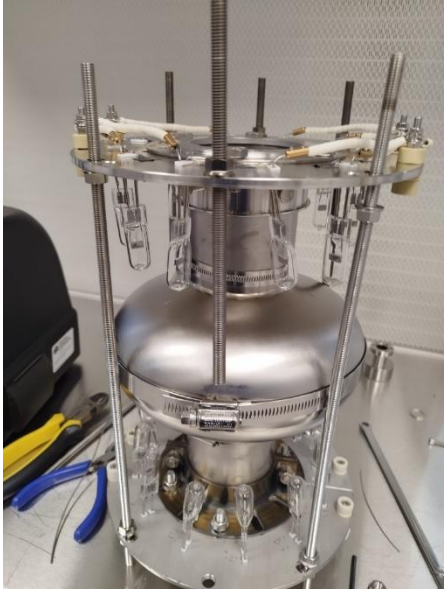

- Unfortunately, this resulted in mixed composition and non superconducting phase (high Sn content)
- May be caused:
- By higher temperature deposition
- Or target non homogeneity

# Comparison of two different target deposition

New target

Old target

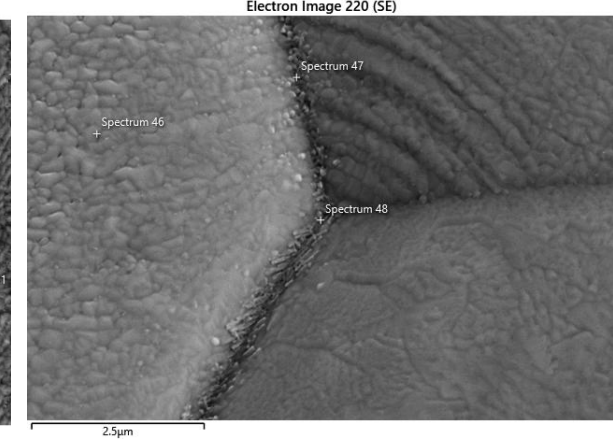
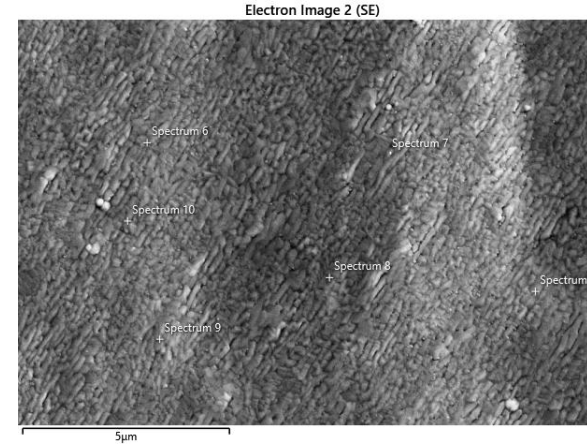
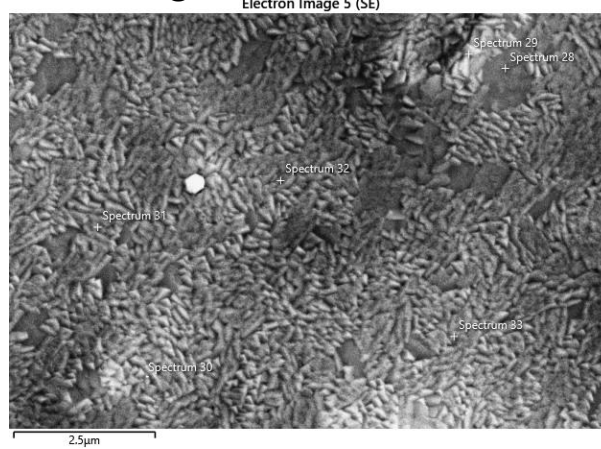
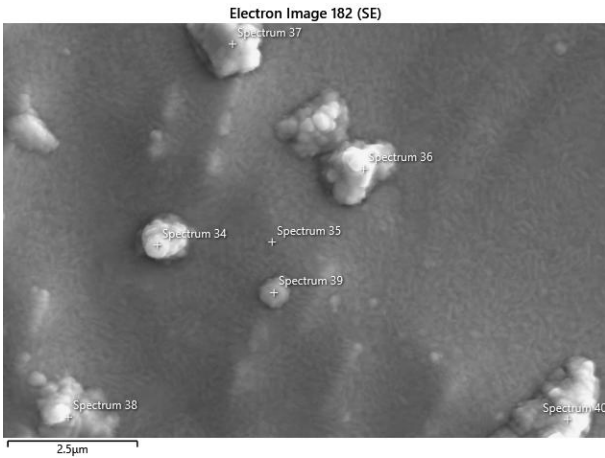

Statistic	Nb	Sn
Max	76.43	26.83
Min	73.17	23.57
Average	75.38	24.62
Standard Deviation	0.76	0.76

Statistic	Nb	Sn
Max	78.05	24.11
Min	75.89	21.95
Average	76.93	23.07
Standard Deviation	0.72	0.72

# Designated 1.3 GHz deposition new facility

- Chamber already mounted
- Manipulators for each magnetron are delivered and mounted
- Few modification is on the way before full assembling.

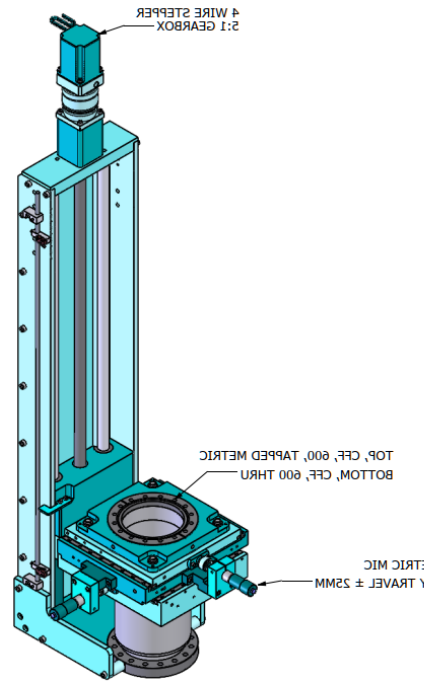
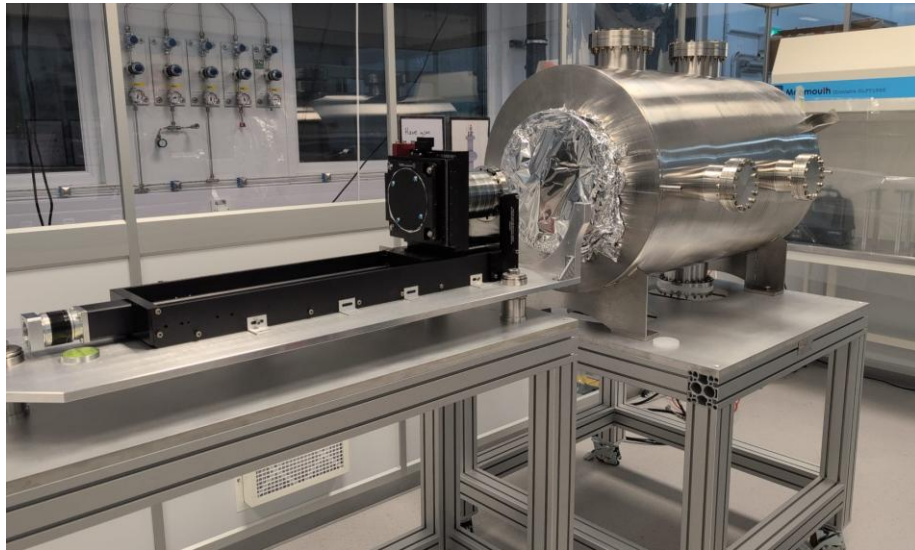

art 2

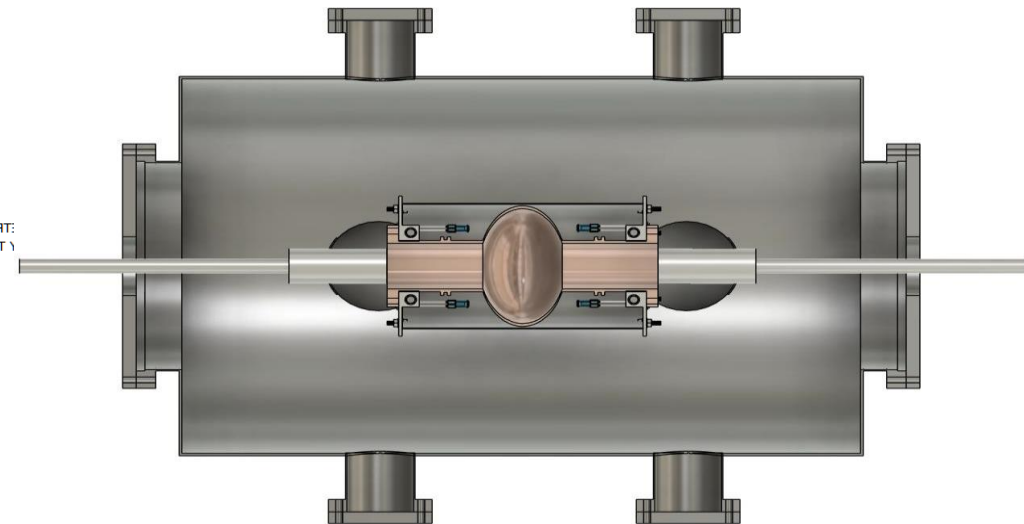
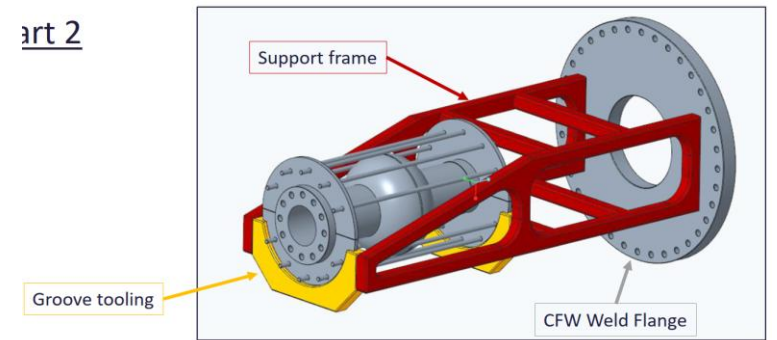

# Nb Deposition of Copper Cavity

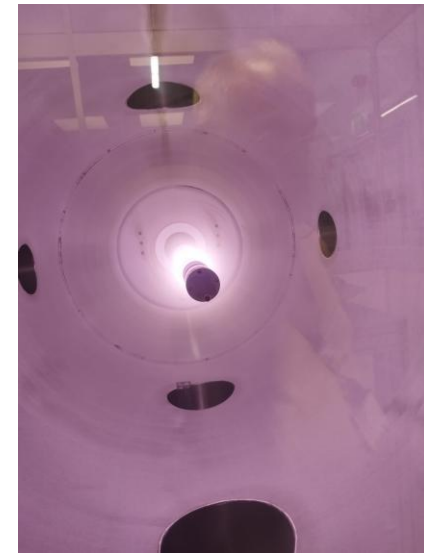
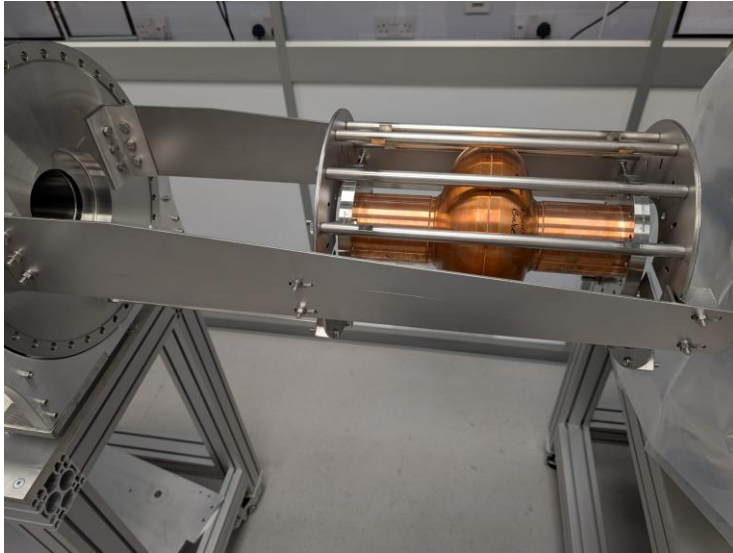
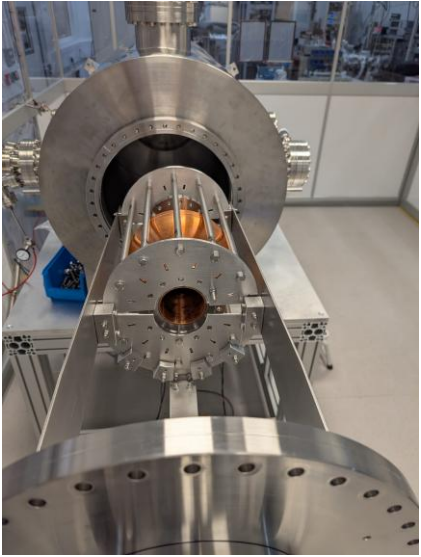

- 1.3 GHz cavity development
  - Optimisation and design of deposition facilities
  - **First 1.3 GHz Nb<sub>3</sub>Sn cavity prototyped by PVD using Nb cavity as substrate**
  - **First Nb deposition on copper cavity soon**
- **A few problems keep persisting at STFC and delaying the progress:**
  - In-house surface polishing & HPR
  - Cylindrical target for Nb<sub>3</sub>Sn (may be)