



WP4: High-Order Mode (HOM) dampers & Fundamental Power couplers (FPC)

Berlin meeting, April 23, 2025

All information contained in this presentation and any accompanying documents is for iSAS project only, and must be treated as strictly confidential.

Any dissemination, distribution or other use of this information without the consent of its owner is prohibited.



Funded by the European Union. Views and opinions expressed are however those of the authors only and do not necessarily reflect those of the European Union or the European Commission. Neither the European Union nor the granting authority can be held responsible for them.



WP4 – HOM dampers and FPC

CERN, CNRS (IJCLab, LPSC), INFN

Convener: Y. GOMEZ MARTINEZ (CNRS/ LPSC)

Main contacts with other partners: V. PARMA (CERN), P. DUCHESNE (CNRS/IJCLab), D. GIOVE (deputy INFN)

Task 4.1: General coordination of WP4

March 24 – March 28

CNRS, INFN

Task 4.2: HOM coupler design

March 24 – August 25

INFN, CNRS, CERN

At 800MHz with the goal to minimize static and dynamic heat loads on the cryogenic circuits of the cryomodule

Task 4.3: Fabrication of HOM couplers

May 25 – December 2026

CERN, CNRS, CERN

4 HOMs 800 MHz with the goal of employing cost and production-time reduction techniques

Task 4.4: Test of HOM couplers

Nov 25 – (March 27)- September 27

CNRS, INFN

On mono-cell and multi-cell 800 MHz at 300 K

Task 4.5: FP coupler design

March 24 – June 25

CERN, CNRS

With the goal to improve sustainability

Task 4.6: Fabrication of FP couplers

July 25 – January 27

CERN, CNRS

4 new 800 MHz FPC with the goal of employing cost and production-time reduction techniques.

Task 4.7: Test of FP couplers

Feb 26 – (June 27) – December 27

CERN, CNRS

Preparation & RF conditioning 800 MHz, 50 kW CW

Task 4.8: BLA design

January 26– May 26

INFN, CNRS

With the goal to cover a very significant gap in the sector

Task 4.9: Fabrication of BLA

May 26 – August 26

INFN, CNRS

Build 1 prototype of the 1,3 GHz BLA with the goal of employing cost and production-time reduction techniques

Task 4.10: Test of ceramics of BLA

Jan 26 – (March 27)- Dec 27

INFN, CNRS, CERN

At room and cryogenic temperature

Only 800 MHz HOMC

New tasks about BLA (replace 1.3 GHz HOMC)



WP4 – HOM dampers and FPC: status/evolution of Task 4.1

General coordination of WP4

- **Past developments**

- 22 WP4 meetings organised, participation to the WP5 meetings
- 2 technical review (800 MHz HOMC & FPC)
- 2 tasks finished (4.2 ‘800 MHz coupler design’ and 4,5 ‘FPC design’)
- 2 milestones (FPC and HOMC design report) sent in time
- Participation to impact risk analysis, 1st periodic report, workplan, amendment

- **Current developments**

- **With WP6 :** Post doc position transfert INFN to IJCLab on progress
- **With WP7:** Interaction with RI (Research Instruments)

- HOMC scheme (CNRS, CERN):**

Configurations studied: 2 probe and 2 hook & 4 hook & 2 hook couplers per cavity

→baseline proposed@5mA : **2 Hook/cav** (IJC Lab)

- It ensures the HOM damping requirements (the longitudinal and transversal impedance thresholds) according to the machine configuration
- It damps better the dangerous mode that are confined within the cavity, exhibit a high (R/Q) (shunt impedance)* QL(loaded quality factor) and are close to a beam harmonic because they can present a risk of resonant effects: TM110 & TE111

Monopole modes: TM010, TM011, TM020, TM021, TM012

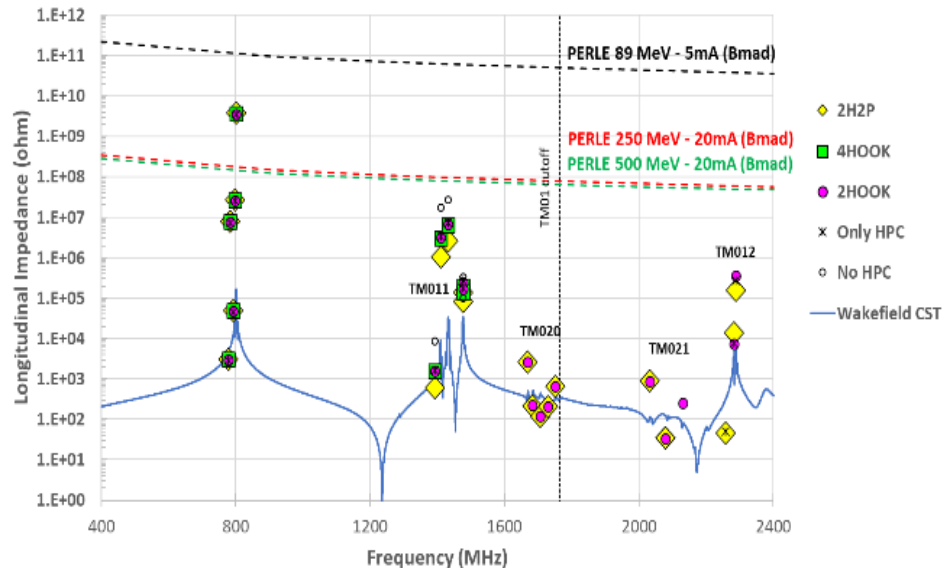

Dipole modes: TE111, TM110, TM111

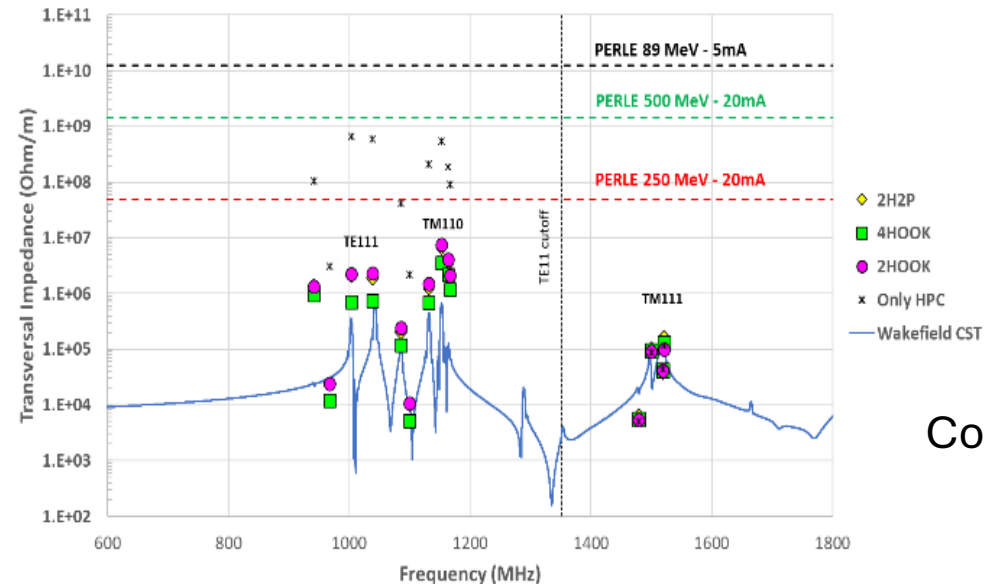

Task finished

Courtesy of P. Duchesne

WP4 – HOM and FPC: status/evolution of Task 4.2

HOM coupler design

- HOOK HOMC optimization (CNRS/IJCLab):**

Based on the RF design of 800 MHz HOOK coupler for HL-LHC (CERN), the coupler was optimized by CNRS

- **RF simulations** (P.Duchesne/IJC Lab) to obtain the best transmission at dangerous mode (TE111 & TM110) and ensuring an effective rejection of the Fundamental mode (TM010)
- **Mechanical integration** (S. Blivet and G. Olivier/IJC Lab) compatible with the WP6 cryomodule
- **Mechanical and thermal calculations** (P. Duchesne/IJC Lab) to minimize static and dynamic heat loads on the cryogenic circuits of the cryomodule, to verify the mechanical strength
- **Multipacting simulations** (A. Placais/LPSC) to check multipacting
- Taking into account the feedback from M. Garlasche & S.Barriere (CERN) about feasibility fabrication

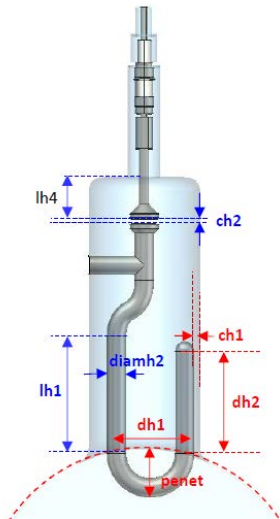

Parameters considered for the RF sensitivity studies

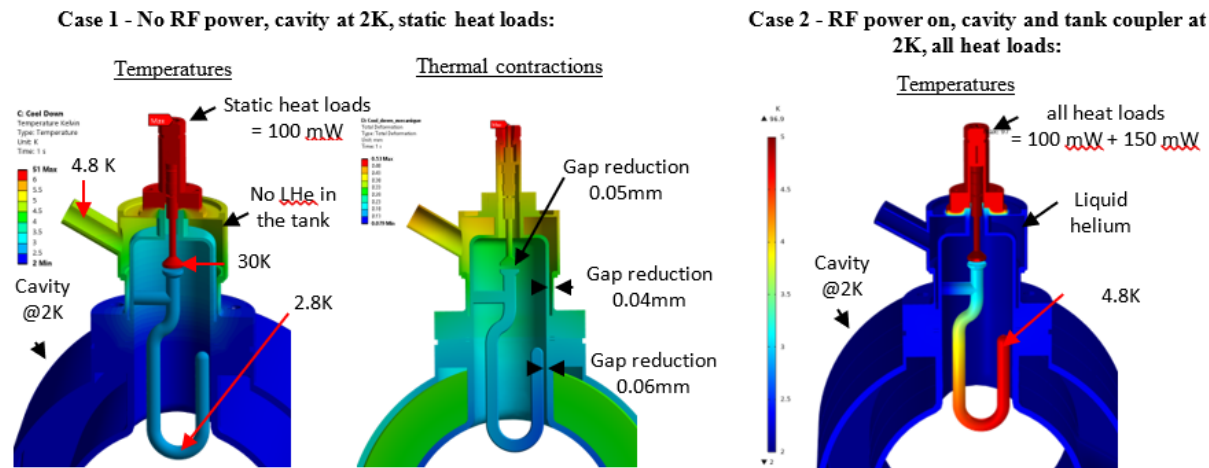

Thermal studies - Case 1: no RF power, cavity at 2K, static heat load s; Case 2: RF power on, cavity and tank coupler at 2K, all heat loads

Courtesy of P. Duchesne

Task finished

WP4 – HOM and FPC: status/evolution of Task 4.3 Fabrication of 800 MHz HOM couplers

- **Past developments**

- CERN has finalised preparation activities for fabrication, based on requests and functional specification from IJC Lab, with fabricability input from CERN
- A detailed manufacturing sequence has been established
- Raw materials have been ordered and received, based on the same specification as the HL-LHC WP4 couplers (316LN stainless steel, OFE copper, RRR300 niobium)

(M.Garlasche & S.Barriere / CERN)

- **Current developments**

- The fabrication of the 4 HOM couplers has started
- Tooling design for final welding steps is ongoing
- Estimated completion date (before final acceptance tests) for 4 prototypes is end Q3-2026

(M.Garlasche & S.Barriere / CERN)

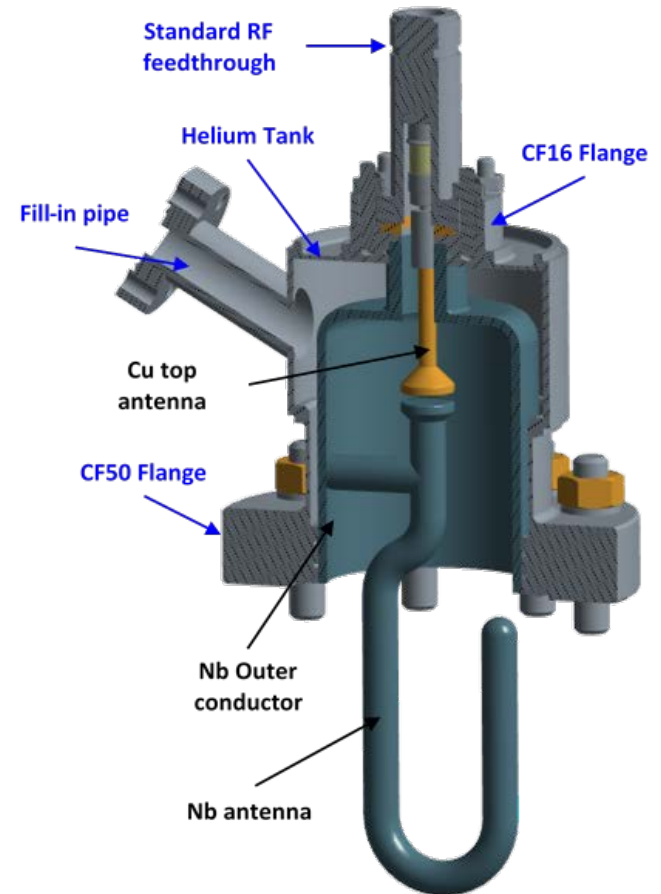

Courtesy of S. Blivet

Hook coupler



WP4 – HOM dampers and FPC : status/evolution of Task 4.4

Test of HOM couplers for WP6

- Start of the task planned for October 2026
- 1 month required to have the HOM test bench operational

Courtesy of J. Angot

Mechanical and RF studies (CNRS/CERN):

- FPC based on the RF design of the 704 MHz SPL (Superconducting Proton Linac) coupler developed at CERN
 - Made **compatible in the mechanical integration** in the WP6 cryomodule and ESS test bench (S. Blivet and G. Olivier)
 - RF simulations** to adapt it to the RF characteristics of the iSAS WP6 Cryomodule (J. Angot and P. Duchesne)

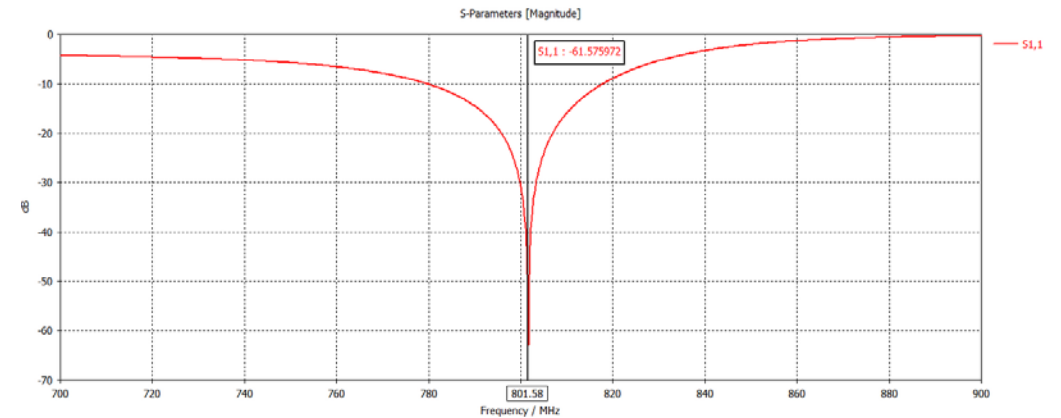

Adaptation of the coupler (S11 parameter)

Parameter	Value	Unit
Operating frequency	801.58	MHz
S ₁₁ parameter at operating frequency	< -30	dB
Required bandwidth at -20 dB	10 MHz	MHz
Maximal power for travelling wave and standing wave, continuous wave	50 CW	kW
External quality factor (Q _{ext}) range	$7 \times 10^6 < Q_{ext} < 1 \times 10^7$	-

- Preliminary multipacting simulations** carried out with results similar to those of SPL FPC (A.Placais and Y. Gómez)

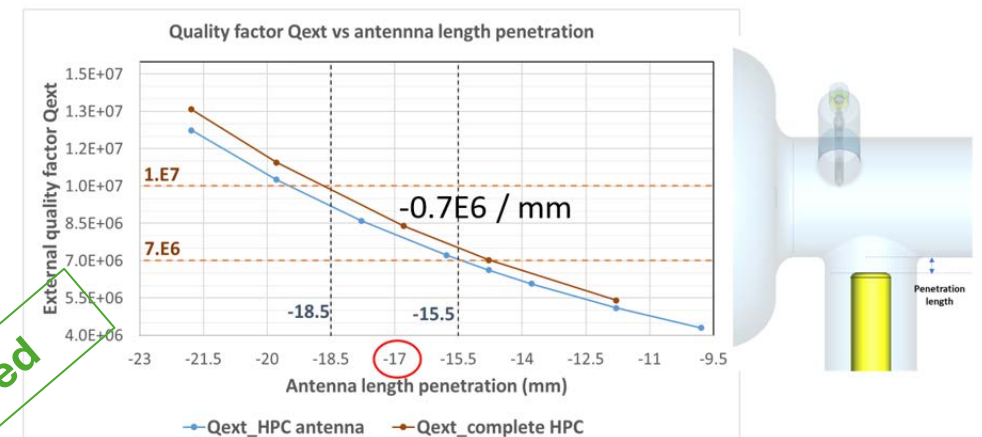

Courtesy of P. Duchesne

Quality factor Qext versus antenna penetration length)

Task finished

- Thermal studies (CERN):**

- Antenna and window air cooling (C. Sharp)**

Goal : to maintain temperatures everywhere in an acceptable range, minimize antenna deformation, prevent condensation on the window, avoid induced stresses in the window and reduce radiation heat loads to the cavity in all operational configuration

Thermo-structural finite element studies on antenna/window assembly.

→Air cooling of at least 400 l/min in antenna circuit (Re 10000 strong turbulent flow)

→Electrical heaters installed on the window to mitigate the risk of condensation if the air supply is interrupted.

Courtesy of C. Sharp

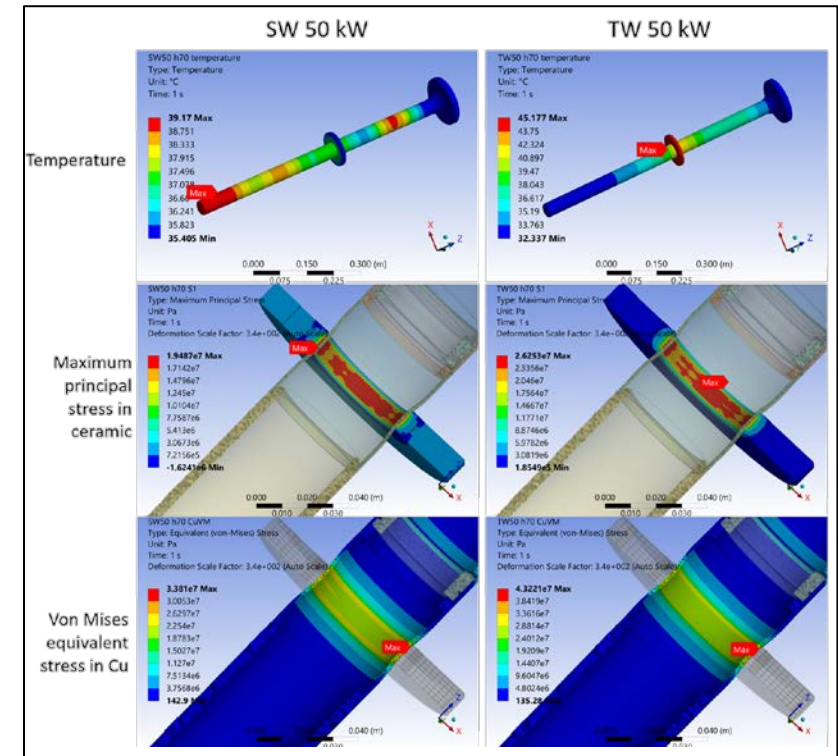
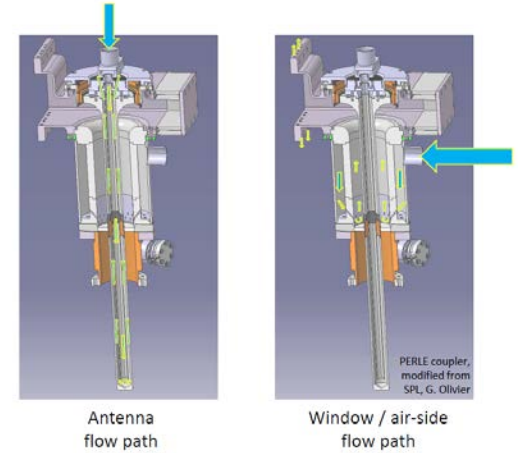

- **Thermal studies (CERN):**

- **Outer conductor cooling (K. Canderan)**

ESS cylindrical double walled tube cooled with supercritical helium flowing

Studies were performed with a numerical model to:

- estimate the heat loads in the outer conductor (conduction, convection, radiation), temperature profiles and RF dissipation according to the position of the maximum magnetic field

→To be considered electrical heaters at warm flange and outlet He pipe don't drop below the dew point

- the equivalent cost to the cryogenic plant in operation
- the helium mass flowrate to minimize the heat loads to the cavity helium bath at 2K
- Impact of the He inlet temperature on cryogenic costs

→Lower the inlet temperature lower the heat loads

- Comparison heat intercepts versus Helium flowing

→Up to 65% energy saving with He flow (0,9 kWel@inlet 5K vs 2kWel@intercepts 5 & 50 K)

Courtesy of K. Canderan

Task finished

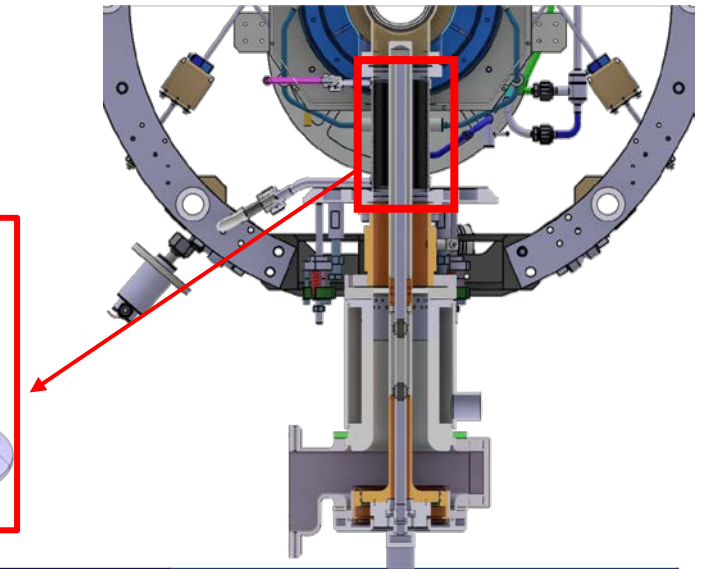
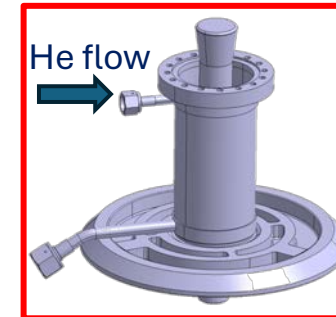

	RF on (full reflection)
Heat released to the He bath @2K	0.5 W (inlet 5.1K) – 1.8W (inlet 9K)
RF power dissipated in the DWT	6.25 W
Radiation heat load to the DWT	0.77 W
Radiation heat load to the He bath @2K	0.5 W
Input heat required	34 W (at warm flange) – 8,2 W (at He outlet pipe)
Liquefaction capacity	23.1 mg/s
Total cryogenic cost [W _{el}] (*)	0,96 kWel (inlet 5,1 K) -2.2 kWel (inlet 9K)

(*) W_{el} calculated assuming 15% of the Carnot efficiency

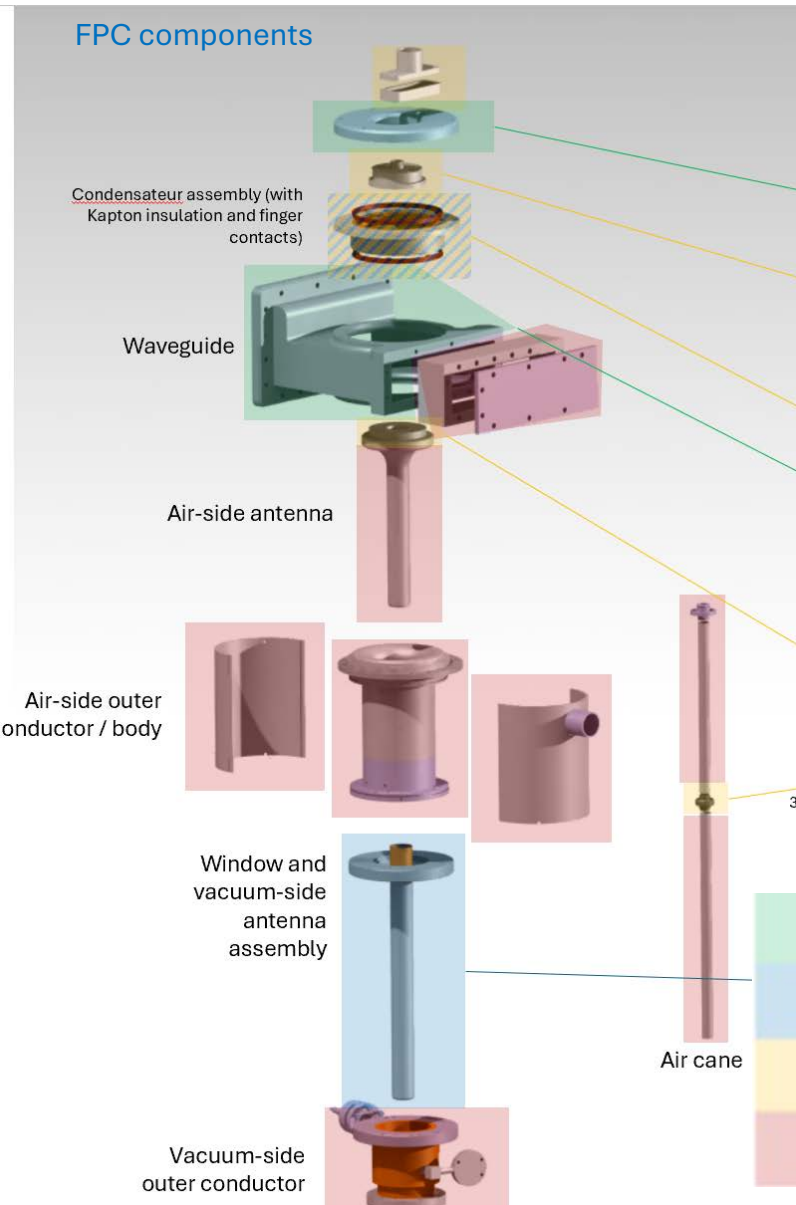

• Past developments

- Inventory of existing components completed
- Vacuum leak tightness of 4x existing SPL antenna/window assemblies verified to 10^{-10} mbar.l.s⁻¹ with He sprayed around ceramic, braze joints, flange and antenna air volume

Courtesy of C. Sharp

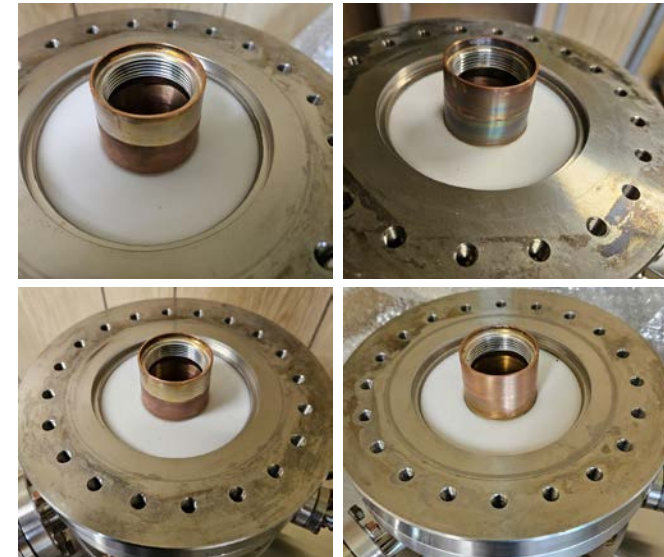

Existing antenna/window assemblies

• Current developments

- Drafting of detailed production drawings is nearing finalisation
- An assembly issue was found with the antenna air supply cane being too long to insert as planned in the WP6 cryomodule
 - An alternative assembly manoeuvre was proposed but challenging due to space constraints.
 - Options to split air cane in two parts were explored but presented risk to FPC function
 - Decision was taken to keep single-part design, at least for tests at ESS.
 - Assembly process is being reviewed, with N. Elias proposing to prepare a raised cryomodule support stand to facilitate insertion in the preparation area at ESS
 - CERN, ESS and CNRS to participate in finding a handling/assembly solution and prepare any required tooling
- Manufacturing plan in preparation pending drawing finalisation.
- Design and preparation of transport cases for handling of existing antenna/window assemblies
 - Extreme care required (only 4 exist – zero contingency)
 - To then allow antenna extraction and inspection to determine modification steps for cutting, re-machining and EB welding while protecting ceramics

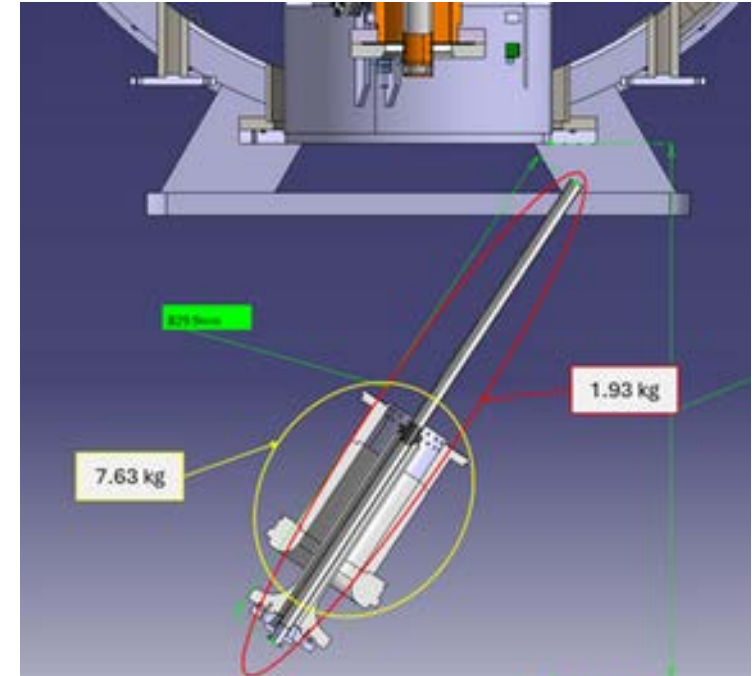

Air cane assembly issue

Courtesy of C. Sharp

- **Past developments**

- Strategy chosen: Do the FPC conditioning up to 50 kW@800MHz
- Studied done to utilize the CERN 704 MHz test box at 800 MHz (S. Gorgi Zadeh /CERN)

- **Current developments**

- Checking the availabilities of electricity and water networks at CERN. Alternative : move the test bench at IJC Lab
- Test cavity external conductor modifications to be prepared
- Cooling requirements to be verified (C. Sharp)

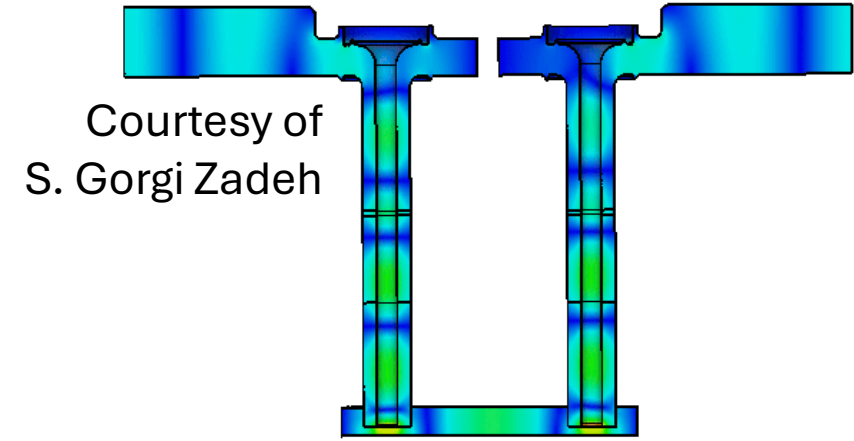

Courtesy of S. Gorgi Zadeh

$$f = 801 \text{ MHz}, d_{\text{tip}} = 18.5 \text{ mm}, P_{\text{in}} = 0.5 \text{ W}$$

Test bench with 704 MHz test box

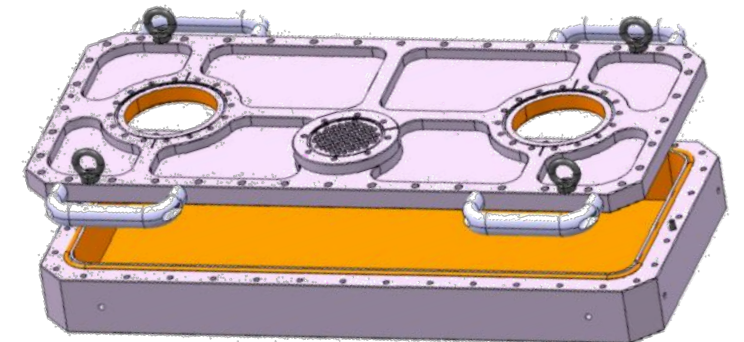

Courtesy of C. Sharp

Goal : to study a BLA at 1,3 GHz dedicated to BriXSino projet and study the feasibility of the technology chosen for the requirements of the iSAS WP6 cryomodule so covering a very significant gap in the sector

• Past developments

- BLA design chosen (INFN)
 - XFEL/ LCLS II design
 - Cooling technology : convey the heat load by conduction through copper stubs directly at the cryogenic temperature (40 – 70 K thermal shield intercept of the cryomodule)
- Baseline ceramic chosen : STL-150D14 from Sienna Technologies (INFN)

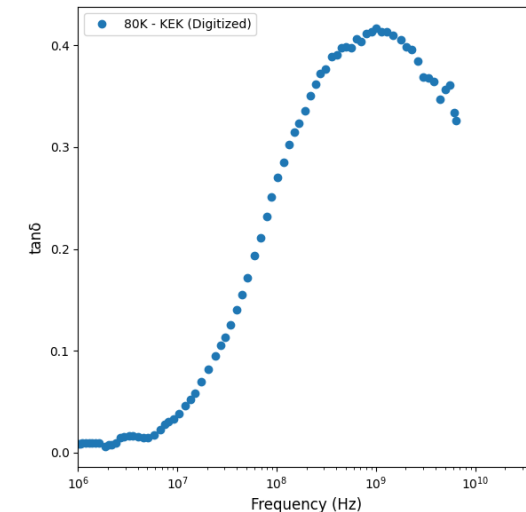
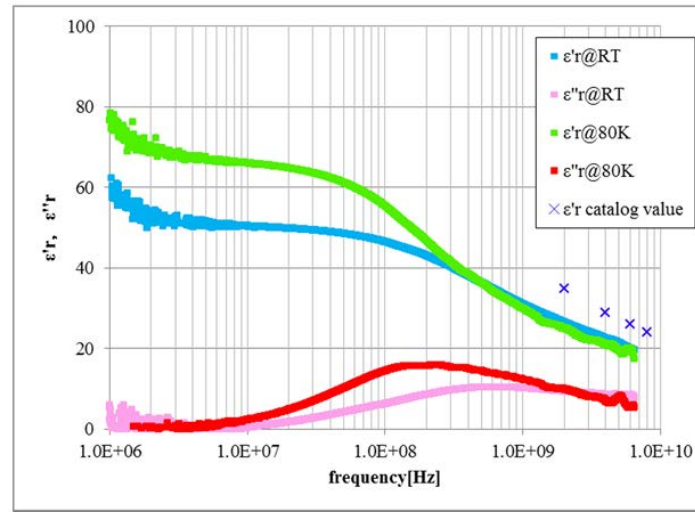
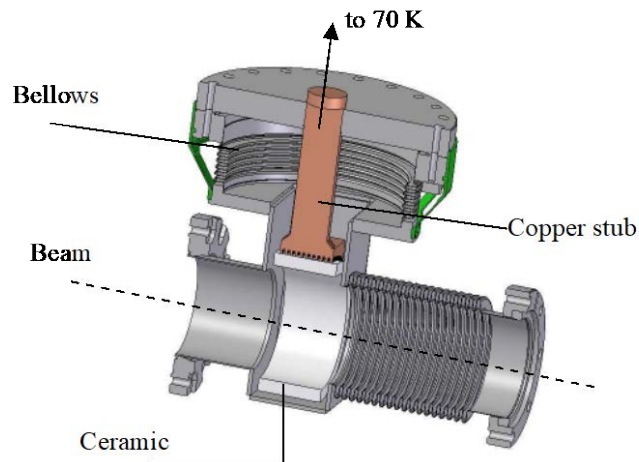

European X-FEL BLA

Courtesy of D. Giove

SiennaTech STL150D14 specifications. from T. Ota et al., Development of HOM dampers for superconducting cavities”, in Proc. PASJ2016, Chiba, Japan, August 2016.

Courtesy of A. Perez Ruiz

• Past developments

- For a 1,3 GHz BLA (INFN, CNRS):
 - Mechanical studies to adapt for BriXSino configuration (INFN)
 - Thermal analysis and a cryogenic design appropriate for 20 W (larger than BriXSino requirements) and 100 W (INFN)
 - Power absorption simulation for different HOM for SiennaTech STL150D ceramic (A. Perez Ruiz, IJC Lab)

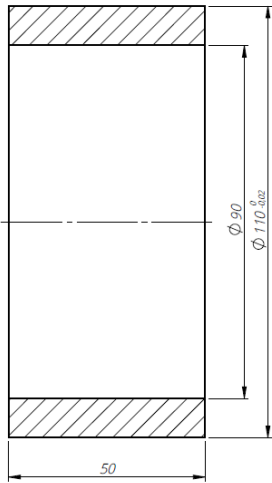

Ceramic size for BriXSino BLA

Courtesy of D. Giove

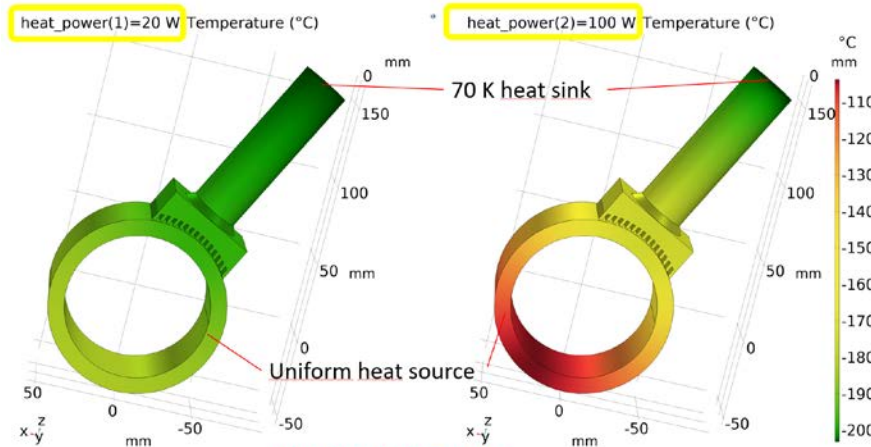

INFN-LASA specific studies

Static load

Thermal analysis

TE₁₁: Linked to dipole HOMs ($f_{\text{cutoff}} = 1.5972$ GHz)
TM₀₁: Linked to monopole HOMs ($f_{\text{cutoff}} = 2.0862$ GHz)

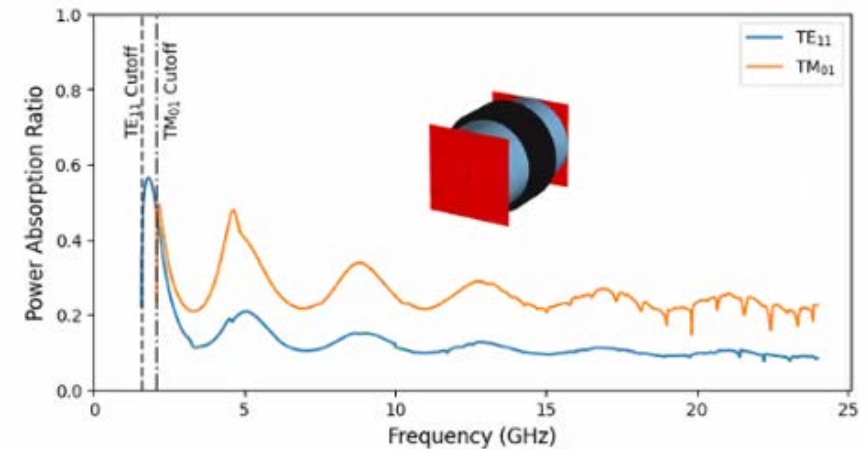

RF simulation

Courtesy of A. Perez Ruiz

- **Past developments**

- For 800 MHz BLA (IJCLab/ CNRS)
 - Power absorption simulation for SiennaTech STL150D and Kyocera SC1000 ceramics (A. Perez Ruiz)

TE₁₁ mode

TM₀₁ mode

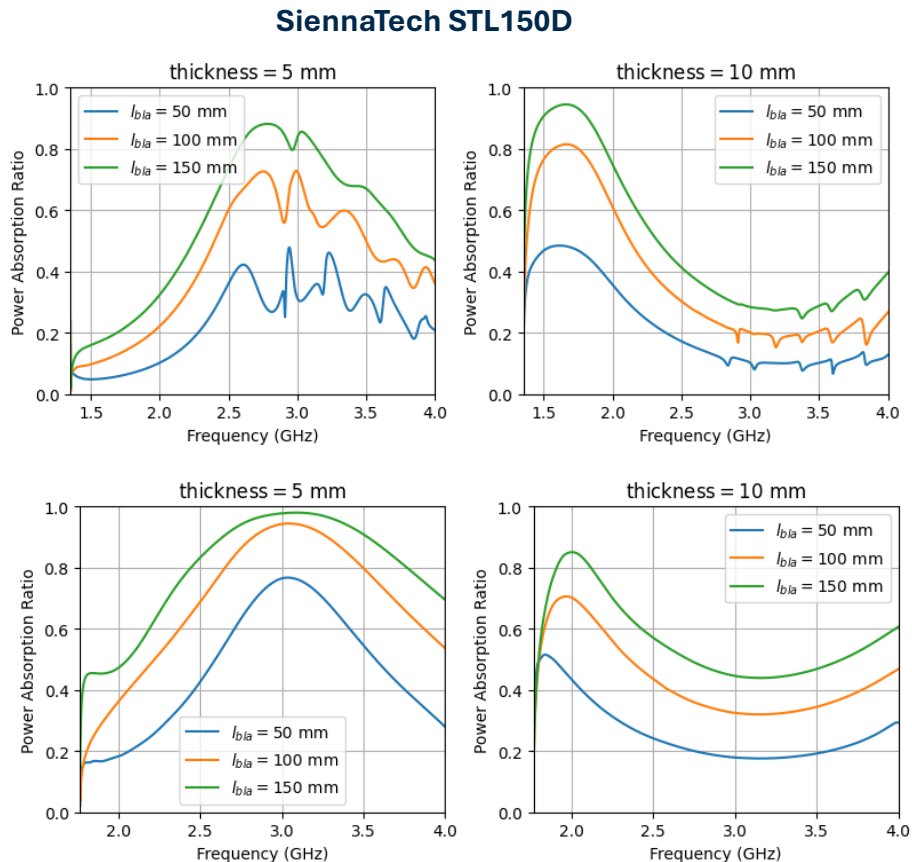

Kyocera SC1000

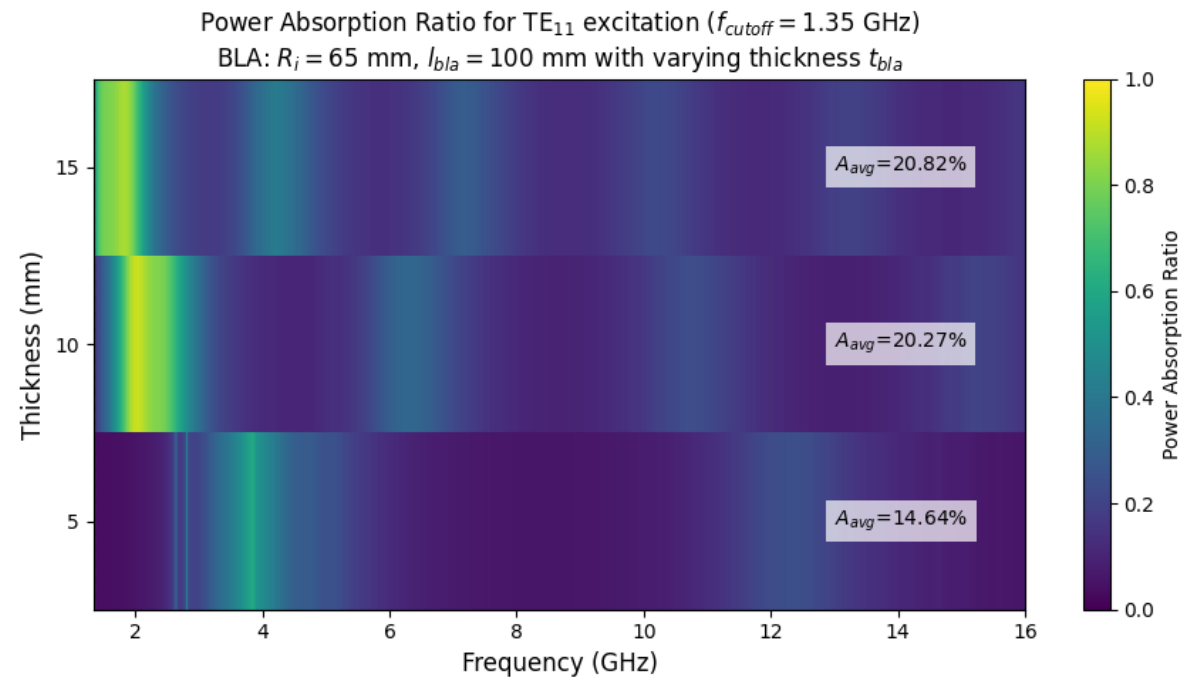

Courtesy of A. Perez Ruiz



WP4 – HOM dampers and FPC : status/evolution of Task 4.8 BLA design

- **Current developments**

- Last CNRS – INFN exchanges to determine last simulations to perform



WP4 – HOM dampers and FPC : status/evolution of Task 4.9 Fabrication of BLA

Goal : *Manufacture one prototype of the 1,3 GHz BLA for BriXSino requirements*

- **Current developments**

- Orders prospect to (D.Giove/ INFN)
 - Sienna Technology (ceramic)
 - Kubara Lamina (full BLA w/wo ceramic)
 - Rial Saes Getters (alternative supply of full BLA (except ceramic and copper)

Goal : Explore various ceramic materials for the BLA applications testing them at room temperature (at CLIC test stand at CERN) and at cryogenic temperature (at new test stand at IJCLab)

• Past developments

- Experimental setup at cryogenic temperature (IJC Lab)
 - Design finished
 - Samples dimensions, sample holder have been defined (A. Miyazaki/ IJC Lab)

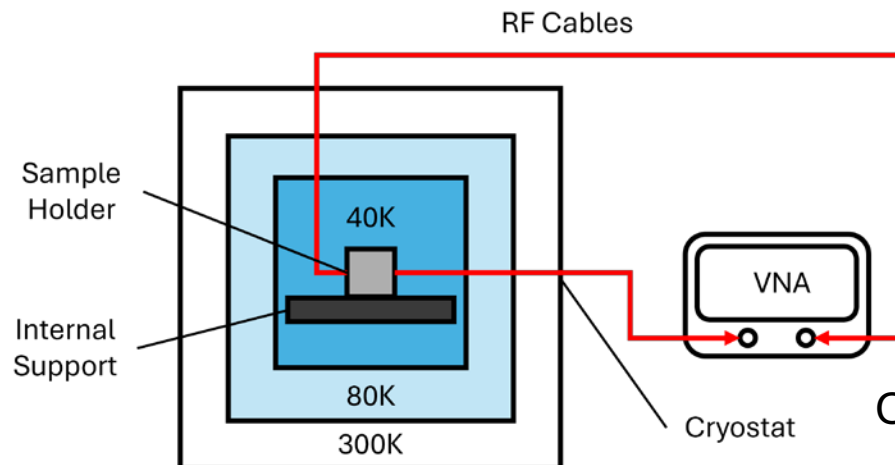

Courtesy of A. Perez Ruiz

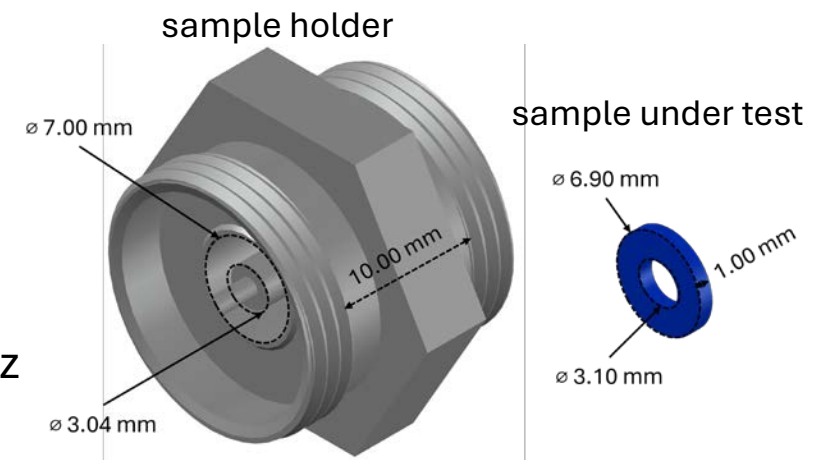

- Past developments**

- Reconstruction algorithm for retrieving (ϵ', ϵ'') from S parameters 'S11, S21' (A. Miyazaki & A. Perez Ruiz / IJC Lab)

$$(\text{Re}S_{11}, \text{Im}S_{11}, \text{Re}S_{21}, \text{Im}S_{21}) \rightarrow (\epsilon', \epsilon'', \mu', \mu'')$$

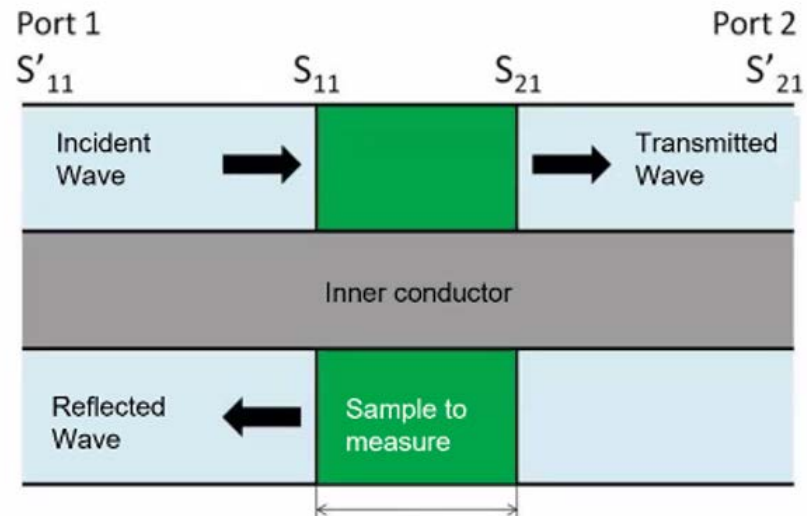

Courtesy of A. Miyazaki



NRW : Nicolson Ross Weir



WP4 – HOM dampers and FPC : status/evolution of Task 4.10

Test of ceramics of BLA

$R_a \approx 1-3 \mu\text{m}$

- **Current developments**

- Fabrication of experimental setup at cryogenic temperature (IJC Lab/ CNRS)
- Buying APC-7 calibration kit, the samples ceramic (IJCLab/ CNRS)



WP4 – HOM dampers and FPC : plans to achieve milestones & deliverables

Timeline in project months (M)				M/D	Related WP	Related task	Description	Status	Risk level
Y2	M16	June	2025	M	WP4	4.5 RF coupler design	Design of FPC coupler	Done	On track
Y2	M18	August	2025	M	WP4	4.2 HOM coupler design	Design of HOM coupler	Done	On track
Y2	M24	Feb	2026	M	WP4	4.1 Coordination of R&D on couplers	Impact risk analysis WP4	Done	On track
Y3	M27	May	2026	M	WP4	4.8 BLA design	Design of BLA	In progress	On track
Y3	M30	August	2026	M	WP4	4.9 Fabrication of BLA	Fabrication of BLA	In progress	On track
Y3	M34	Dec	2026	M	WP4	4.3 Fabrication of HOM couplers	Fabrication of HOM couplers	In progress	On track
Y3	M35	January	2027	M	WP4	4.6 Fabrication of RF couplers	Fabrication of FPCs	In progress	On track
Y4	M37	March	2027	M	WP4	4.10 Test of ceramics for BLA	Test of ceramics for BLA	In progress	On track
Y4	M37	March	2027	M	WP4	4.4 Test of HOM couplers	Test of HOM couplers	Not started	On track
Y4	M40	June	2027	M	WP4	4.7 Test of RF couplers	Test of FPC couplers	Not started	On track
Y4	M43	Sept	2027	D	WP4	4.4 Test of HOM couplers	Report qualification HOM couplers on cavities at 300 K	Not started	On track
Y4	M43	Sept	2027	D	WP4	4.10 Test of ceramics of BLA	Test of ceramics for BLA	In progress	On track
Y4	M46	Dec	2027	D	WP4	4.7 Test of RF couplers	Report on RF test of 800-MHz FPC at 50 kW CW	Not started	On track



WP4 – HOM dampers et FPC : plans to achieve milestones & deliverables

Nom de la tâche	Début	Fin	2024				2025				2026				2027				2028							
			Tri 1	Tri 2	Tri 3	Tri 4	Tri 1	Tri 2	Tri 3	Tri 4	Tri 1	Tri 2	Tri 3	Tri 4	Tri 1	Tri 2	Tri 3	Tri 4	Tri 1	Tri 2	Tri 3	Tri 4				
To Demarrage ISAS projet	Ven 01/03/24	Ven 01/03/24	◆ 01/03																							
FPC	Lun 03/06/24	Ven 17/12/27	-----																							
Design	Lun 03/06/24	Lun 30/06/25	03/06 [blue bar] 30/06																							
Manufacturing (qty 4)	Mar 01/07/25	Lun 30/11/26	01/07 [blue bar] 30/11																							
M	Ven 29/01/27	Ven 29/01/27	◆ 29/01																							
Test / RF Conditioning (qty 4)	Mar 01/12/26	Ven 30/04/27	01/12 [blue bar] 30/04																							
M	Mer 30/06/27	Mer 30/06/27	◆ 30/06																							
D	Ven 17/12/27	Ven 17/12/27	◆ 17/12																							
800 MHz HOM coupler	Jeu 30/05/24	Jeu 30/09/27	-----																							
Design	Jeu 30/05/24	Mer 23/07/25	30/05 [green bar] 23/07																							
Manufacturing (qty 4)	Jeu 24/07/25	Ven 30/10/26	24/07 [green bar] 30/10																							
M	Ven 18/12/26	Ven 18/12/26	◆ 18/12																							
Test (qty 4)	Lun 02/11/26	Mer 27/01/27	02/11 [green bar] 27/01																							
M	Mer 31/03/27	Mer 31/03/27	◆ 31/03																							
D	Jeu 30/09/27	Jeu 30/09/27	◆ 30/09																							
1,3 GHz BLA	Lun 15/09/25	Jeu 30/09/27	-----																							
Design	Lun 15/09/25	Ven 29/05/26	15/09 [hatched bar] 29/05																							
M	Ven 29/05/26	Ven 29/05/26	◆ 29/05																							
Manufacturing (qty 1)	Lun 01/06/26	Lun 31/08/26	01/06 [hatched bar] 31/08																							
M	Lun 31/08/26	Lun 31/08/26	◆ 31/08																							
Tests (Qty 1)	Lun 31/08/26	Mer 31/03/27	31/08 [hatched bar] 31/03																							
M	Mer 31/03/27	Mer 31/03/27	◆ 31/03																							
D	Jeu 30/09/27	Jeu 30/09/27	◆ 30/09																							
tf	Mer 01/03/28	Mer 01/03/28	◆ 01/03																							

today



WP4 – HOM dampers and FPC : Points of attention

- For risk analysis :

Critical risks & risk management strategy					
Risk No	Description	Probability (on a scale 1<4)	Severity (on a scale 1<4)	Criticality (PxS)	Mitigation measures
	Cost increase on cryomodule components	2	2	4	Major components will be manufactured by iSAS partners, additional funds will be covered by partners of the consortium
	Delay in delivery of cryomodule components	2	2	4	Major components will be manufactured by iSAS partners, adaptation/simplification of components possible
	Test benches not available	3	3	9	Search for alternative test benches
	Performances not achieved	1	4	4	Extensive studies have been carried out and controls of each stage (manufacturing, preparation and assembly) will be implemented
	Lack of candidates for post doc position	1	2	2	Maximize job advertisements

- To add:

- For FPC, there are only 4 SPL antennas/windows (zero contingency) → Extreme care is required for transport, cutting, new machining and EB welding
- For HOM, the next milestone 'BLA design report' due in a month, last exchanges ongoing



Thank-you for your attention

Yolanda Gómez Martínez on behalf of the WP4 team:

- **CERN** : Simon Barriere, Sebastien Calvo, Karin Canderan, Marco Garlasche, Vittorio Parma, Calum Sharp
- **INFN** : Dario Giove (deputy)
- **CNRS / IJCLab** : Sebastien Blivet, Patricia Duchesne, Akira Miyazaki, Gilles Olivier, Guillaume Olry, Axel Perez Ruiz
- **CNRS / LPSC** : J. Angot, Yolanda Gómez Martínez (convener), Adrien Plaçais