

# **Development, commissioning and high-current CW operation of 166.6 MHz HOM-damped SRF modules at HEPS**

**Pei Zhang**

**(Institute of High Energy Physics, CAS)**



# Outline

---

- Introduction to HEPS
- Introduction to HEPS RF system
- Development of 166.6 MHz SRF modules
- Installation, commissioning & operation
- Summary

# **Introduction to HEPS**

# Landscape of the 4<sup>th</sup>-gen SR facilities

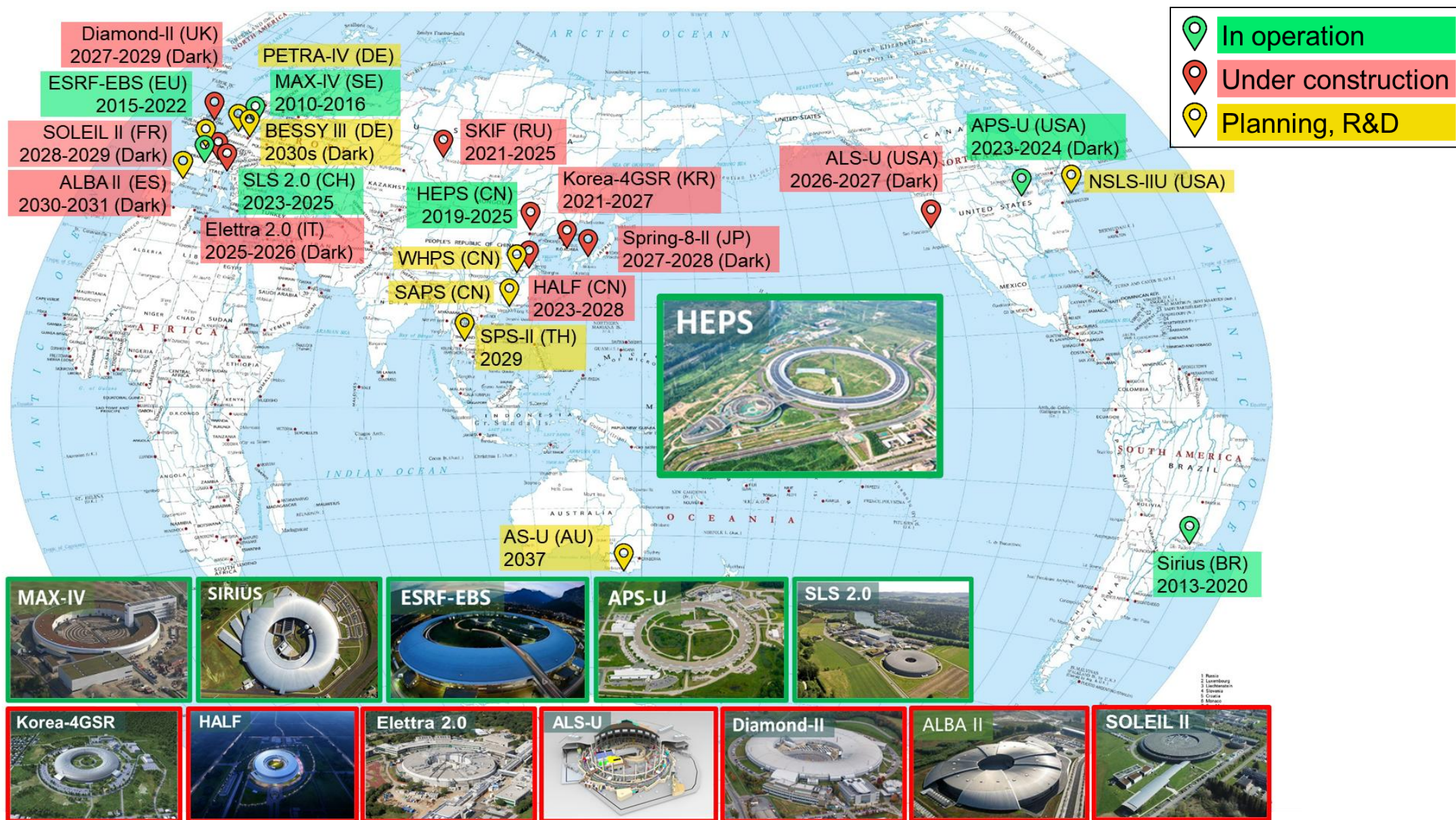

# High-energy 4<sup>th</sup>-gen SR facilities



**ESRF-EBS**  
6 GeV  
In op. since 2020

**ESRF-EBS (EU)**  
2018-2020 (Dark)



**6 GeV**

**PETRA-IV (DE)**  
2020s

**HEPS (CN)**  
2019-2025



**HEPS**  
6 GeV  
In op. since 2026

**SPring-8-II (JP)**  
2027-2028 (Dark)



**SPring-8: 8 GeV**  
**SPring-8-II: 6 GeV**

**APS-U (USA)**  
2023-2024 (Dark)



**APS-U: 6 GeV**  
In op. since 2024

	In operation
	Under construction
	Planning, R&D

**LEGEND**

- Capital
- Other city
- Continental boundary
- International boundary
- Regional boundary
- Military demarcation line

比例尺: 1:141 000 000  
图例号: GSC20115446号  
自然资源部 编绘

- 1 Russia
- 2 Luxembourg
- 3 Liechtenstein
- 4 Slovenia
- 5 Croatia
- 6 Monaco
- 7 San Marino
- 8 Bosnia and Herzegovina
- 9 Serbia
- 10 Montenegro
- 11 Vatican City
- 12 Albania
- 13 North Macedonia
- 14 Moldova
- 15 Armenia
- 16 Azerbaijan
- 17 Lebanon
- 18 Palestine
- 19 Israel
- 20 United Arab Emirates
- 21 Qatar
- 22 St. Kitts and Nevis
- 23 Antigua and Barbuda
- 24 Dominica
- 25 St. Lucia
- 26 St. Vincent and the Grenadines

# High Energy Photon Source (HEPS)

- **Project outline**

- A diffraction-limited SR light source (4<sup>th</sup>-gen)
- **The 1<sup>st</sup> high-energy SR light source in China**
- **Location:** Huairou Science City, Beijing
- **Construction time:** 06.2019 – 12.2025
- **Land:** 650,667 m<sup>2</sup>, **Building:** 125,000 m<sup>2</sup>
- **Budget:** 4.76B CNY (~\$652M)(incl. materials, civil constr. & commissioning, **excl. labor costs**)
- **Funding:** Central government + Local government + Chinese Academy of Sciences

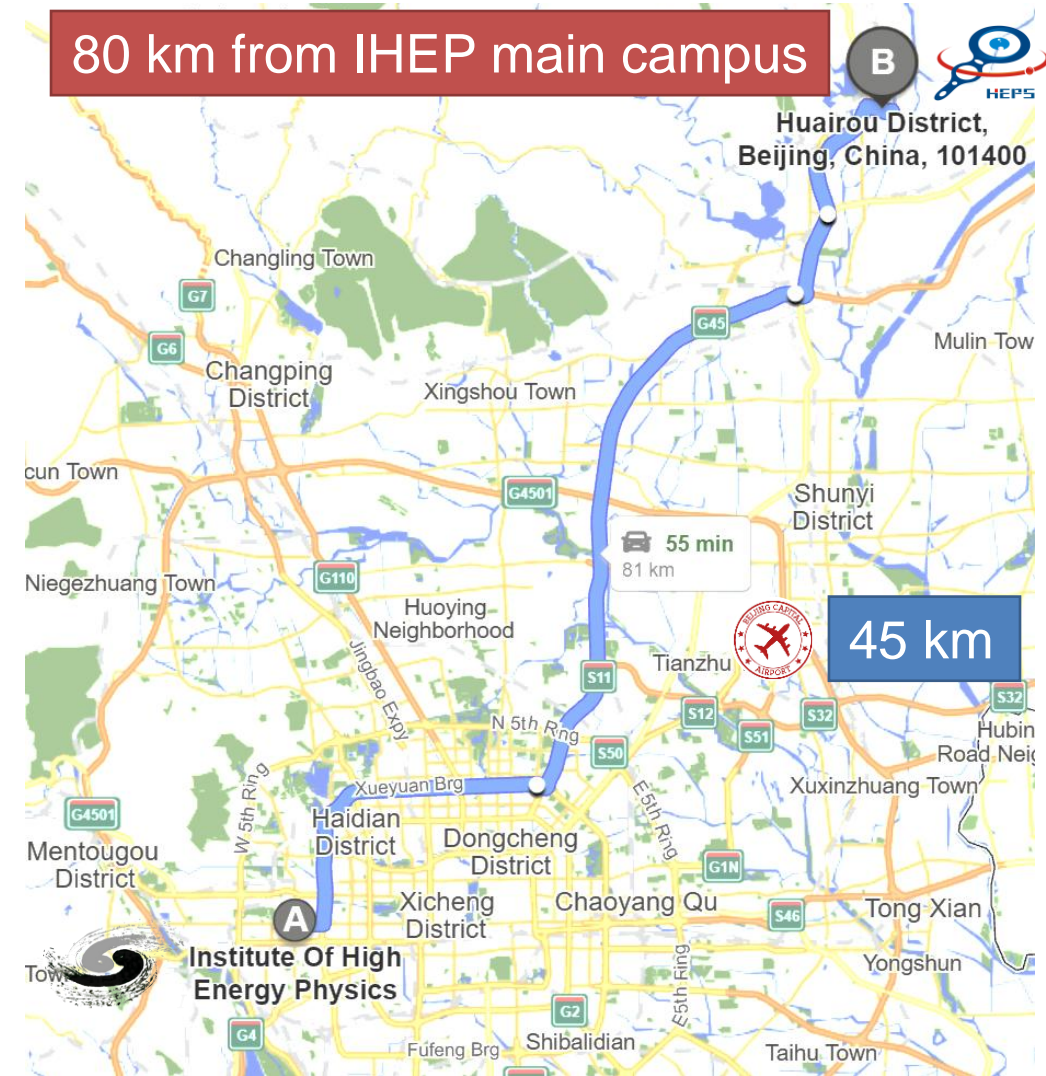

# HEPS in Huairou Science City (Beijing)

100.9 km<sup>2</sup>

5 large science facilities



# HEPS in general

- **HEPS accelerator complex**

- Linac: 500 MeV, 49 m
- Booster: 500 MeV to 6 GeV, 1 Hz, 454 m
- Storage ring: 6 GeV, top-up, 1360 m

Commissioned in 2025, currently in pilot runs

Parameter	Value	Unit
Beam energy	6	GeV
Circumference	1360.4	m
Lattice type	Hybrid 7BA	
Hori. Natural emittance	34.2	pm·rad
Brightness	$> 1 \times 10^{22}$	*
Beam current	200	mA
Injection mode	Top-up	-

\*: phs/s/mm<sup>2</sup>/mrad<sup>2</sup>/0.1%BW

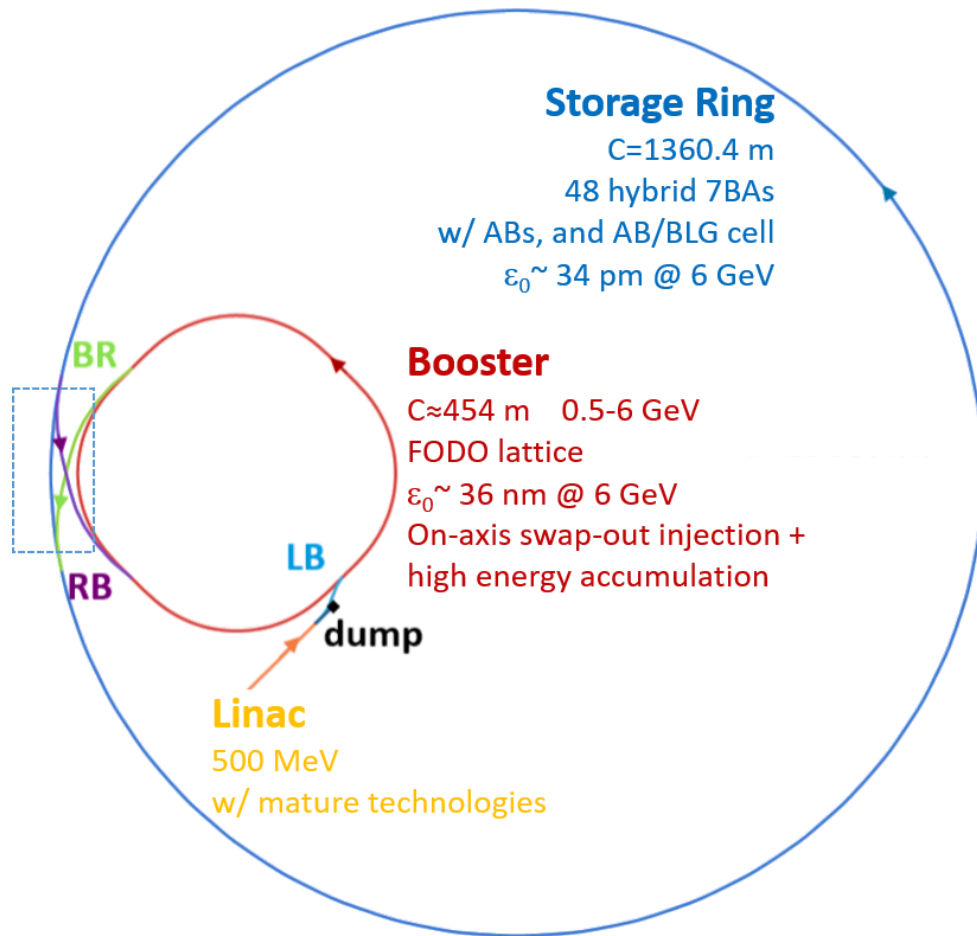

[1] Y. Dong *et al.*, *IPAC2026*, TUI2M02.  
 [2] H. Xu *et al.*, *RDTM 7*, 279–287 (2023).  
 [3] Y. Peng *et al.*, *RDTM 4*, 425–432 (2020).  
 [4] C. Meng *et al.*, *RDTM 4*, 497–506 (2020).

# Milestones: construction



**May 12, 2022**  
The Linac Vacuum-sealing in the tunnel completed



**Jan. 13, 2023**  
The Booster Vacuum-sealing in the tunnel completed



**Feb. 1, 2023**  
The first girder was installed in the storage ring tunnel



**Mar. 14, 2023**  
The first electron beam

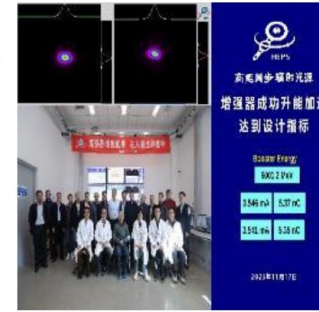

**Nov. 17, 2023**  
Electron Beam Ramped Up to 6 GeV



**Aug. 18, 2024**  
Electron beams with currents higher than 10mA were successfully stored.



**Oct. 12, 2024**  
the SR X-ray emitted from the R21 wiggler was successfully transmitted to the end station.



**June 29, 2019**  
Groundbreaking ceremony



**July 1, 2020**  
The first steel beam was installed

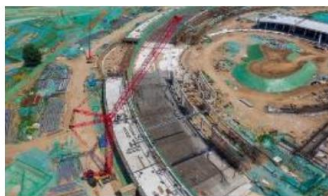

**Apr. 13, 2021**  
Utility installation in NO.2 Hall commenced



**June 27, 2021**  
Roof-sealing work for the main ring building completed



**June 28, 2021**  
HEPS Installs First Piece of Accelerator Equipment in Linac Tunnel.



**Nov. 3, 2023**  
Civil Construction for ancillary buildings completed



# Milestones: commissioning

- 2024.07, commissioning of SR started
- 2025.03 ~ 2025.05, joint commissioning of accelerator and beamlines
- 2025.05 ~ 2025.08, installation of SRF cavities and IDs, re-alignment of BS and SR
- 2025.08 ~ 2025.10, beam current ramped up to 100mA, KPPs delivered

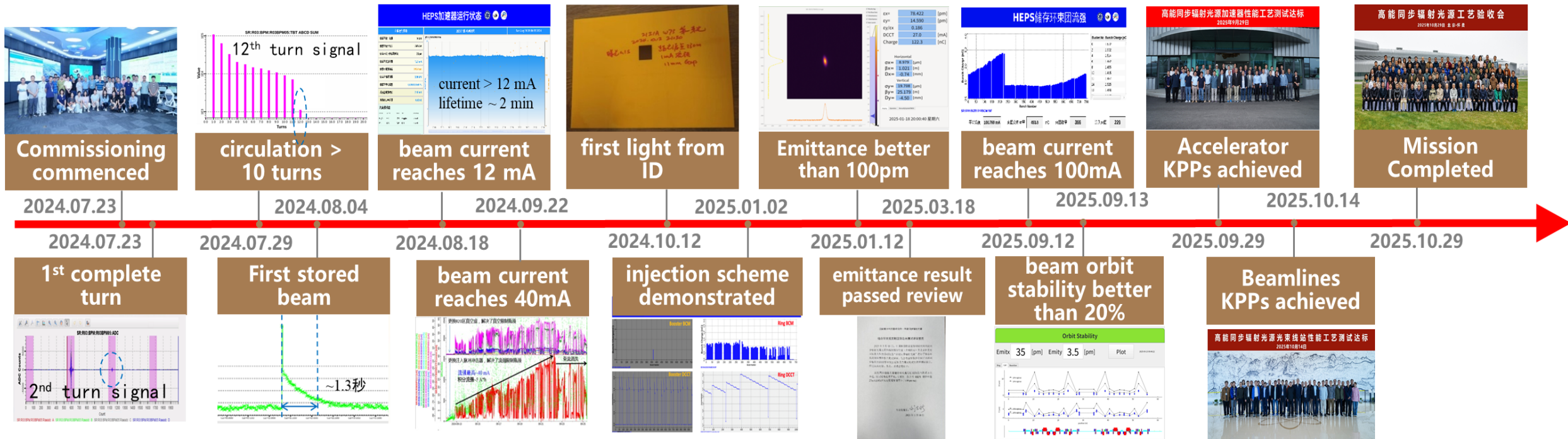

# **Introduction to HEPS RF system**

# RF work package: definition

- **Goal:** The design, construction and commissioning of the radio frequency system for the **booster ring** and the **storage ring** of the High Energy Photon Source (HEPS).
- **Objectives**
  - Complete the development, integration and commissioning of 6 sets of 499.8 MHz normal-conducting RF systems, 5 sets of 166.6 MHz SRF systems and 2 sets of 499.8 MHz SRF systems with the following specifications fulfilled.

## Design specification of the HEPS RF System

Parameter	BS	SR (main)	SR (HC)
RF frequency	499.8 MHz	166.6 MHz	499.8 MHz
Number of cavities	6	5	2
RF technology	NCRF	SRF	SRF
RF voltage per cavity ( $V_c$ )	$\geq 1.35$ MV	$\geq 1.1$ MV	$\geq 1.7$ MV
Cavity $Q_0$ (at $V_c$ )	$\geq 29000$	$\geq 5 \times 10^8$	$\geq 1 \times 10^9$
Cavity field amplitude stability (pk-pk)	$\pm 1\%$	$\pm 0.1\%$	$\pm 0.1\%$
Cavity field phase stability (pk-pk)	$\pm 1^\circ$	$\pm 0.1^\circ$	$\pm 0.1^\circ$
RF power per transmitter	$\geq 90$ kW	$\geq 200$ kW	$\geq 200$ kW
HOM control	Inlet water T.	Heavy damping	Heavy damping

# RF work package: scope

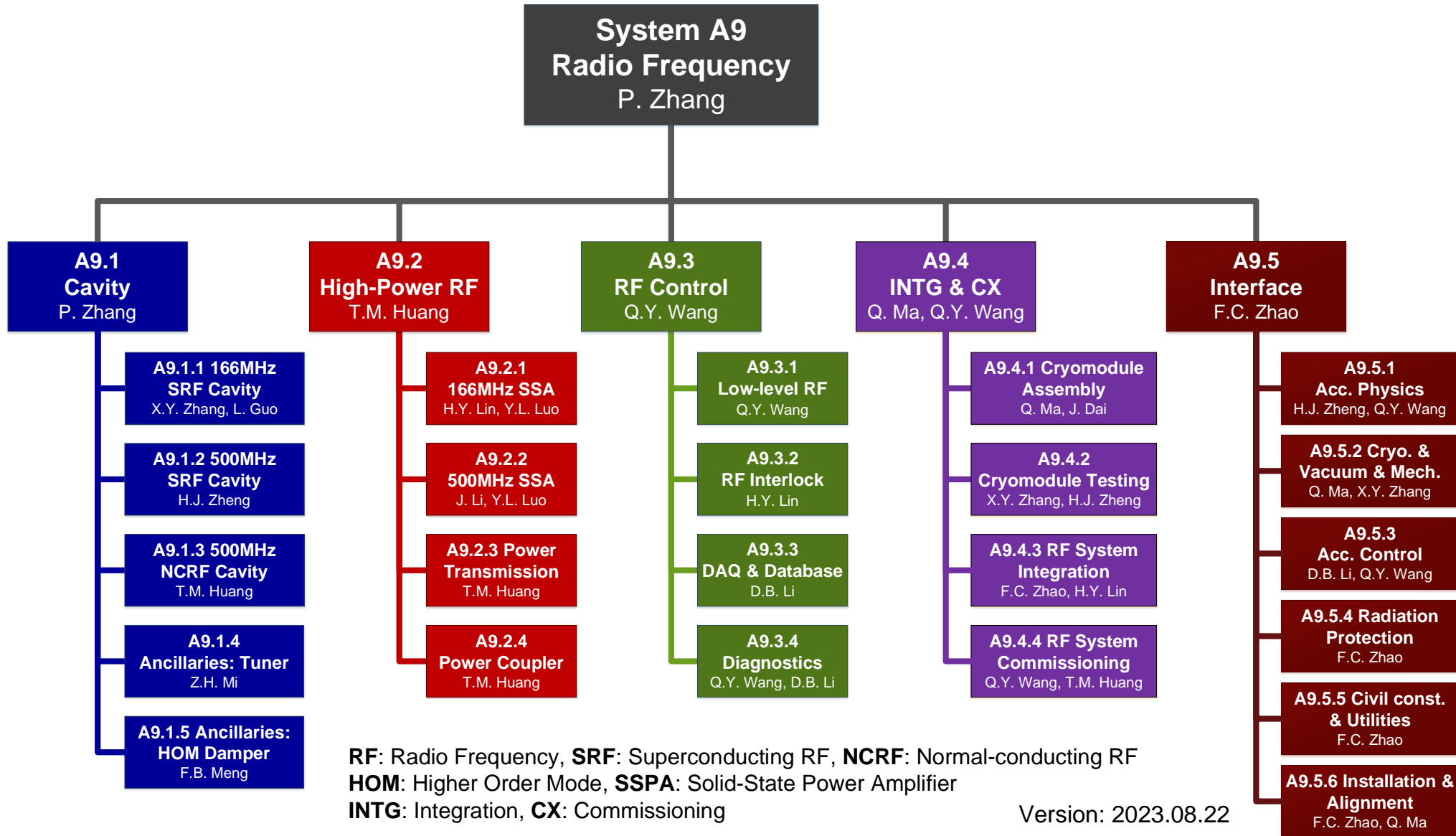

P. Zhang, "HEPS RF System Project Management Plan", *IHEP Internal Note*: IHEP-HEPS-AC-RF-TR-2018-003-V3, 2023.

# RF work package: main deliverables

---

- **RF cavities**

- 5 sets of 166.6 MHz SRF cavity modules
- 2 sets of 499.8 MHz SRF cavity modules
- 6 sets of 499.8 MHz NCRF cavities

- **High-power RF**

- 5 sets of 166.6 MHz 260 kW solid-state power amplifiers
- 2 sets of 499.8 MHz 260 kW solid-state power amplifiers
- 6 sets of 499.8 MHz 100 kW solid-state power amplifiers

- **RF controls**

- 5 sets of 166.6 MHz RF control systems
- 8 sets of 499.8 MHz RF control systems

**7 SRF modules**  
**6 NCRF cavities**  
**2.4MW CW SSAs**  
**13 RF controls**

# Main features of HEPS RF system

- Double-frequency RF system: 166.6 MHz + 499.8 MHz
- Active harmonic RF for bunch lengthening, compatible w/ on-axis swap-out & on-axis accumulation injections
- SRF for storage ring, normal-conducting RF for booster ring
- Heavy damping of higher order modes for storage-ring SRF cavities
- Solid-state amplifiers (SSAs) for all RF transmitters, digital low-level RF control

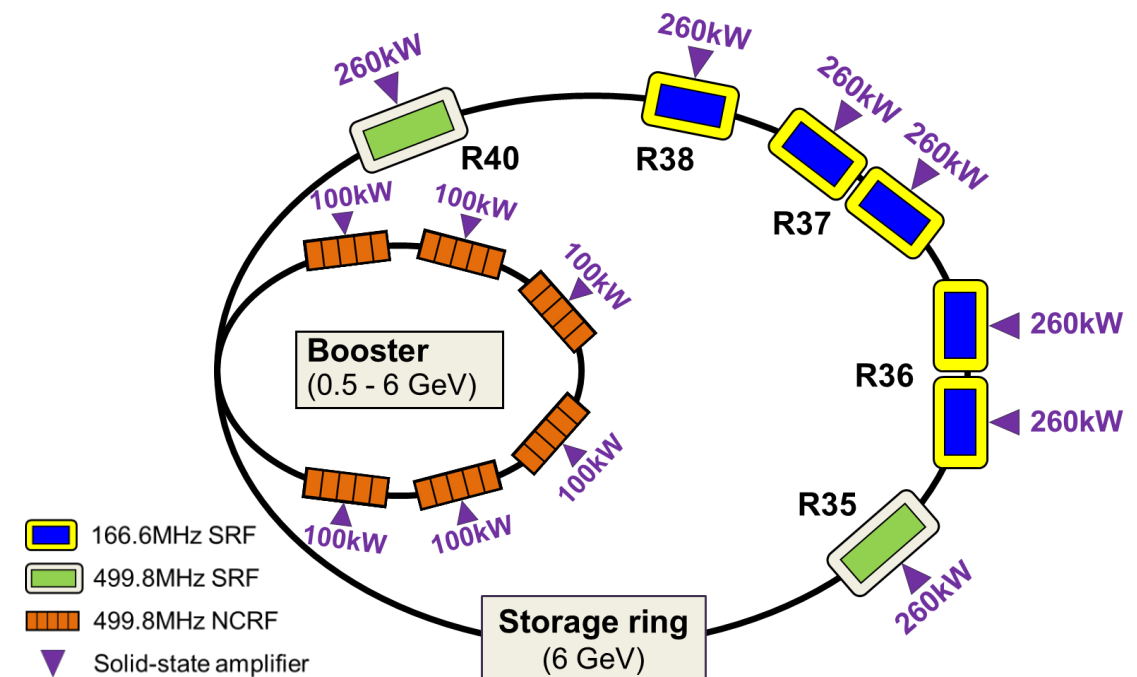
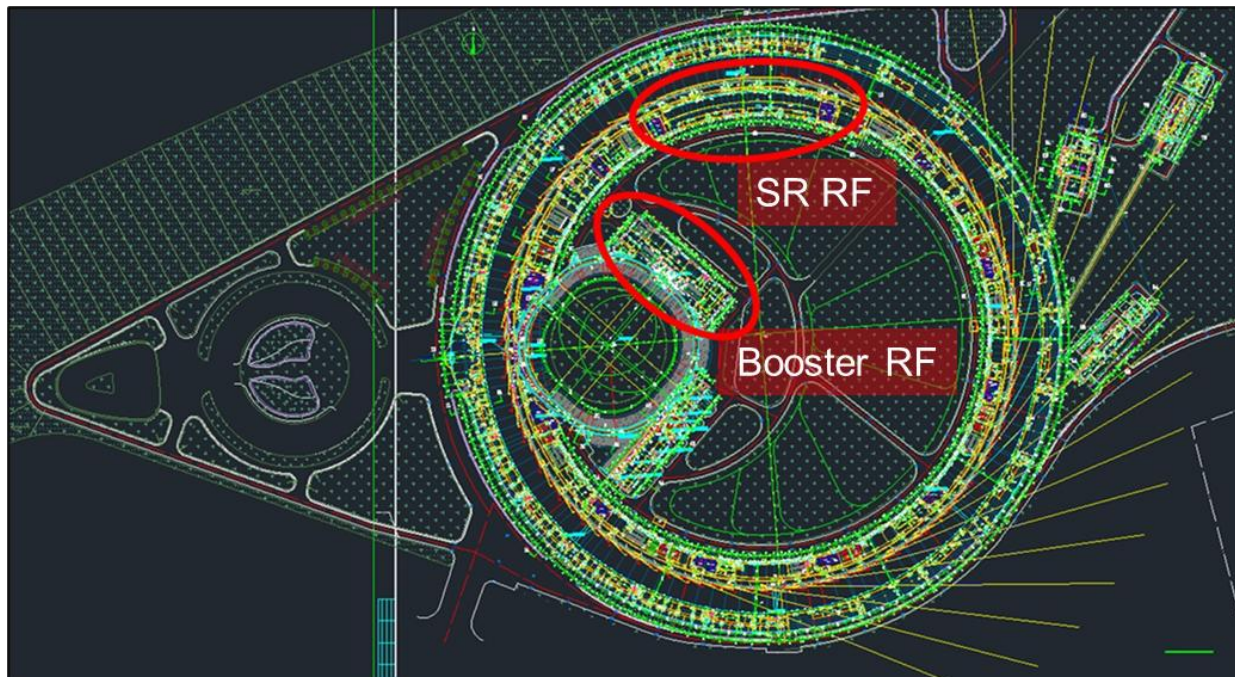

P. Zhang *et al.*, "Radio-frequency system of HEPS", *Radiation Detection Technology and Methods* 7, 159-170 (2023).

# Main RF parameters

Parameter	Booster	SR (main)	SR (HC)	Unit
RF frequency	499.8	166.6	499.8	MHz
Total RF voltage	2 – 8	5.4	0.91	MV
Cavity technology	Normal-conducting	Superconducting	Superconducting	-
Cavity type	5-cell	$\beta=1$ quarter-wave	1-cell elliptical	-
Technology readiness	Mature product	In-house new dev.	In-house dev.	-
No. of cavities	6	5	2	-
RF voltage per cavity	1.35 (op.) 1.9 (design)	1.2 (op.) 1.5 (design)	0.91 (op.) 1.75 (design)	MV
RF power per cavity (max)	70 (61 cav. + 9 beam)	191	105	kW
No. of transmitters	6	5	2	-
RF power per transmitter	100 (c.w.)	260 (c.w.)	260 (c.w.)	kW
Transmitter technology	SSA	SSA	SSA	-
LLRF control stability (p-p)	$\pm 1\%$ , $\pm 1^\circ$	$\pm 0.1\%$ , $\pm 0.1^\circ$	$\pm 0.1\%$ , $\pm 0.1^\circ$	-
LLRF technology	Digital LLRF (in-house dev.)			-

# RF cavities

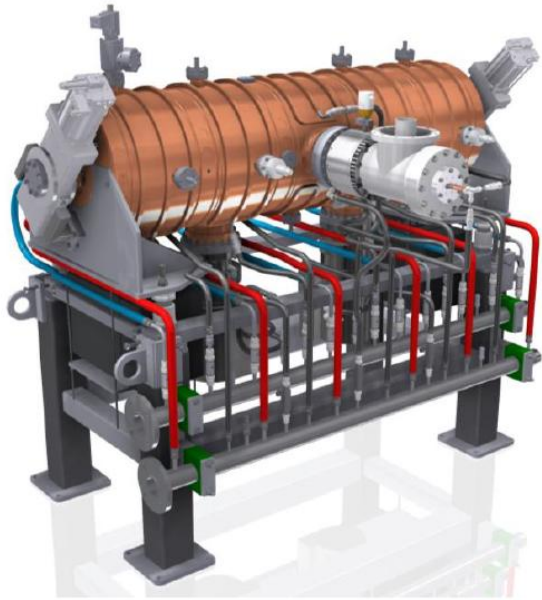

500MHz PETRA-type  
5-cell copper cavity  
(Booster)

Procured from RI  
(Minor modifications)

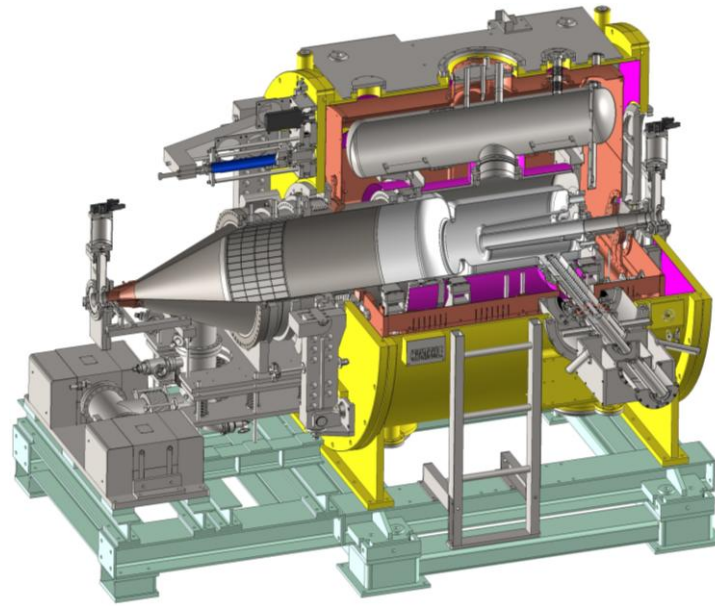

166MHz quarter-wave  
 $\beta=1$  **SRF** cavity  
(Storage ring)

In-house development  
(**New design**)

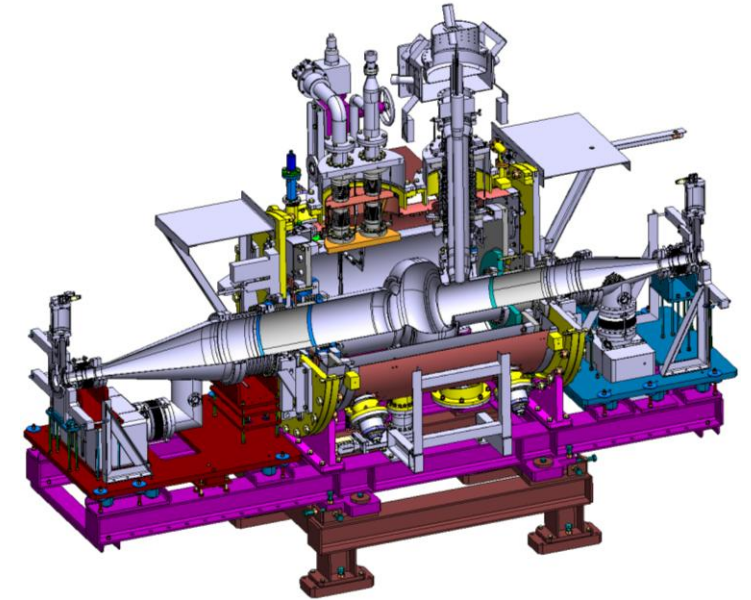

500MHz KEKB-type  
1-cell elliptical **SRF** cavity  
(Storage ring)

In-house development  
(Mechanically-improved)

- [1] T. Huang *et al.*, "Design modification and high-power tests of the 500 MHz normal-conducting 5-cell cavities for HEPS", *JINST* 19, P06031 (2024).
- [2] P. Zhang *et al.*, "Development and high-current cw operation of 166.6 MHz high-power, HOM-damped  $\beta = 1$  quarter-wave SRF modules at HEPS", *Phys. Rev. Accel. Beams* 29, 032002 (2026).
- [3] H. Zheng *et al.*, "Development and tests of the 499.8 MHz srf cryomodules for HEPS", *JINST* 19, P10031 (2024).

# High-power RF

- Transmitter type: SSA
- Power transmission
  - 9-3/16" coaxial rigid lines for 166MHz
  - WR1800 rectangular waveguide for 500MHz
- High-power circulator for each SR RF station

## Booster RF

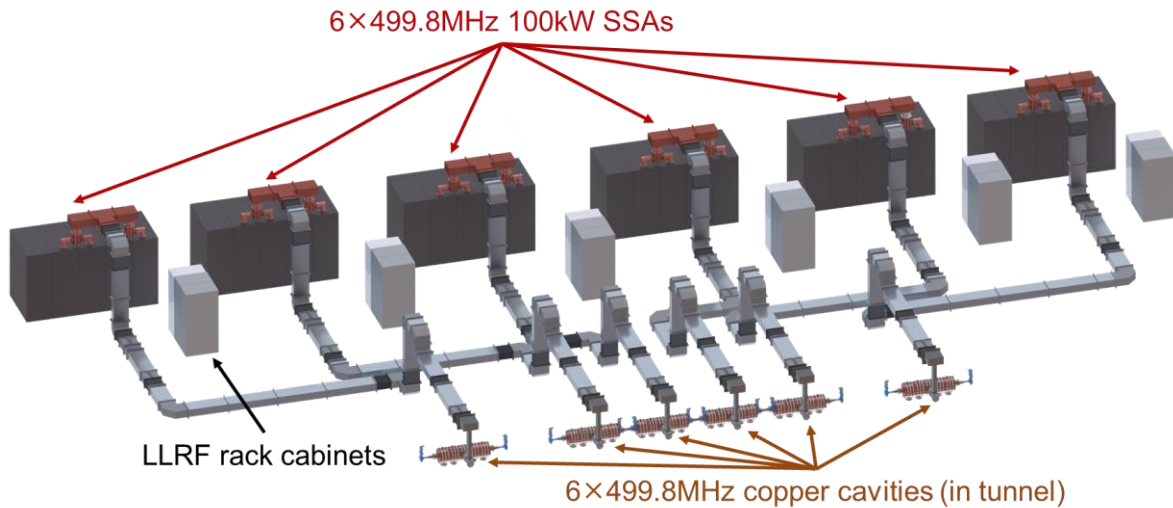

RF hall surface area: 1600 m<sup>2</sup>

## Storage-ring RF

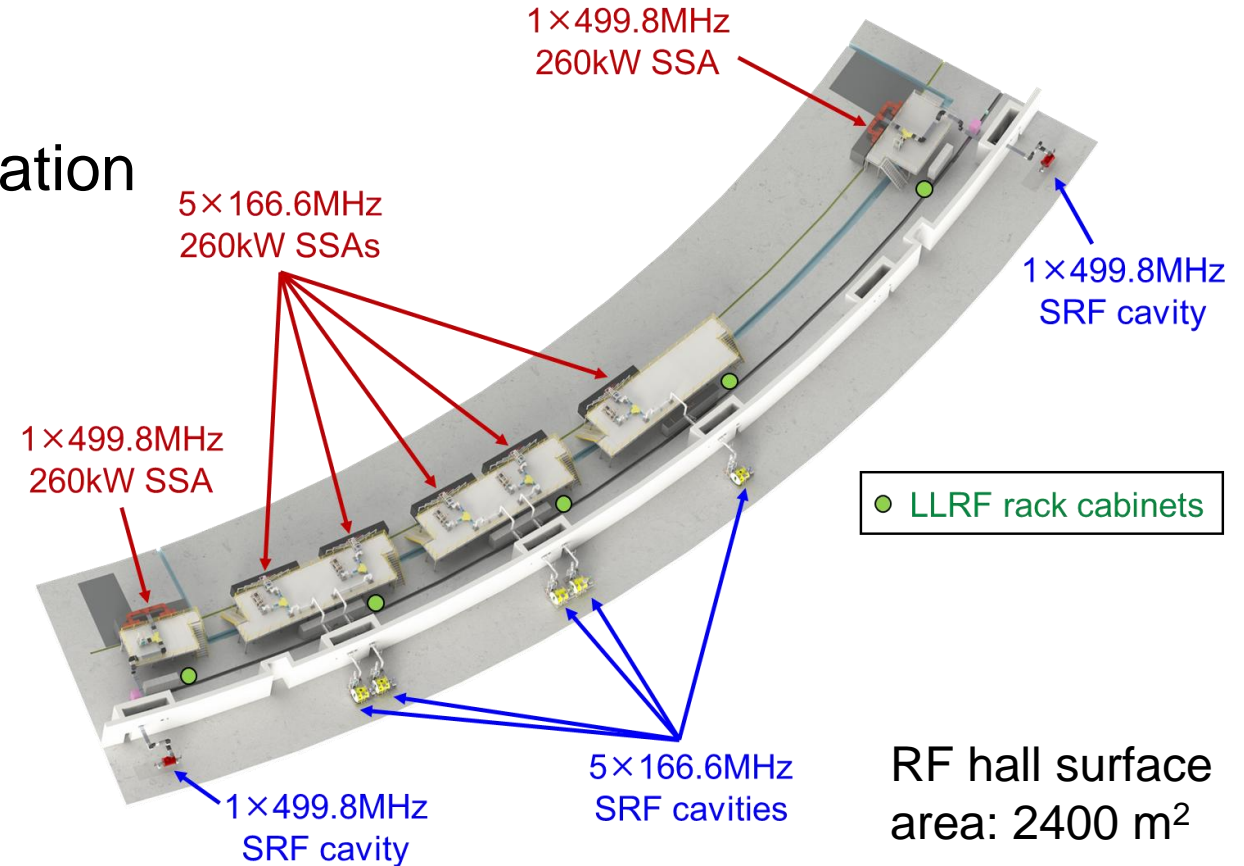



# High-level schedule of RF WP

HEPS RF System	2019		2020				2021				2022				2023				2024				2025			
Sub-system	Q3	Q4	Q1	Q2	Q3	Q4	Q1	Q2	Q3	Q4	Q1	Q2	Q3	Q4	Q1	Q2	Q3	Q4	Q1	Q2	Q3	Q4	Q1	Q2	Q3	Q4
500MHz NCRF cavities																										
Booster SSAs																										
Booster LLRF																										
Booster RF instl. (S1, S1b)																										
Booster beam CX (S1, S1b)																										
166MHz SRF modules																										
500MHz SRF modules																										
SR SSAs																										
SR LLRF																										
SR RF instl. (S1c)																										
SR beam CX (S1c)																										
SR RF instl. (S2)																										
SR beam CX (S2)																										

# Milestones of RF WP

---

- Oct. 2021, prototype SSAs passed SAT
- Nov. 2021, first 166MHz SRF cavity developed and exceeded specifications
- Oct. 2022, all normal-conducting cavities passed SAT
- Oct. 2023, Booster RF system commissioned
- Nov. 2023, first 166MHz CM developed and exceeded specifications
- Jun. 2024, all 500MHz CMs developed and exceeded specifications
- Sep. 2024, all SR SSAs passed SAT
- Jun. 2025, all 166MHz CMs assembled and tested, exceeded specifications
- Jul. 2025, all 166MHz and 500MHz SRF cavities installed in SR
- Aug. 2025, storage-ring SRF system commissioned
- Sep. 2025, 166MHz + 500MHz SRF cavities accelerated 100mA beam
- Oct. 2025, HEPS commissioned and passed acceptance tests



# **Development of 166.6 MHz SRF modules**

# Choice of RF frequency

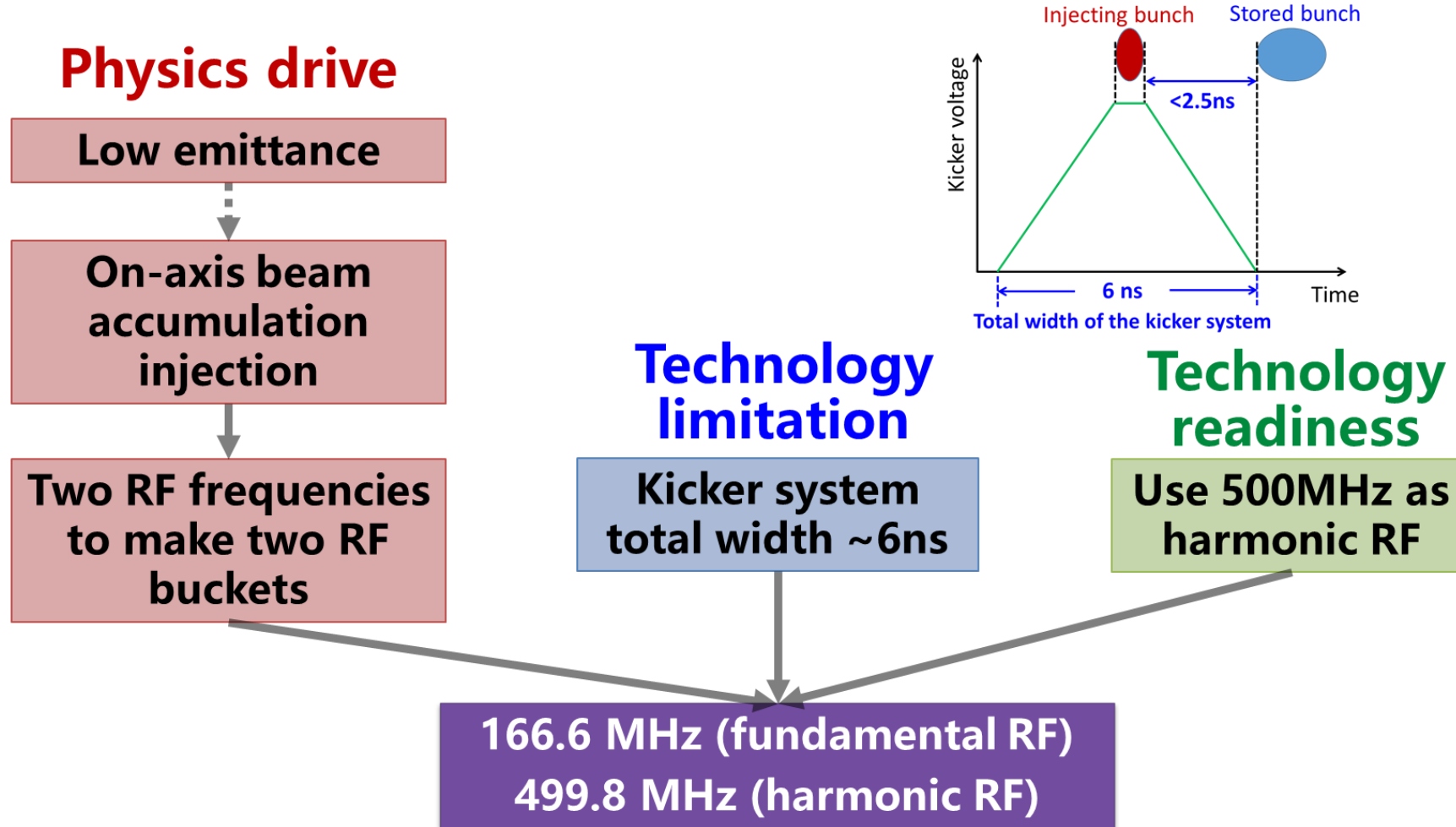

- [1] G. Xu *et al.*, "On-axis Beam Accumulation Enabled by Phase Adjustment of a Double-frequency RF System for ...", *IPAC2016*, WEOAA02.
- [2] Z. Duan *et al.*, "Top-up injection schemes for HEPS", *eeFACT2016*, TUT2H4.
- [3] S. Jiang and G. Xu, "On-axis injection scheme based on a triple-frequency rf system for ...", *Phys. Rev. Accel. Beams* 21 (110701) 2018.

# 166MHz cavities: demanding requirements

## Design challenges

- **Low frequency SRF: 166.6MHz,  $\beta=1$ , SRF**
- High current: 200mA → **heavy HOM damping:**  $Q_L < 1000$
- **High RF power:** 190kW c.w. per cavity
- **Compact:** limited straight section space (6 meters for 2 cavities)
- **Reasonable cryogenic heat load** and **acceptable loss factor**
- Stable operation (user facility): **large margin** in RF parameters

## Specifications

Parameter	Value	Unit
RF frequency	166.6	MHz
No. of cavities	5	-
Operating temperature	4.2	K
Design voltage ( $V_d$ )	1.5	MV
Design gradient	12.5	MV/m
$Q_0$ at $V_d$ (VT)	$>1 \times 10^9$	-
$E_{peak}$ at $V_d$	$<40$	MV/m
$B_{peak}$ at $V_d$	$<65$	mT
Operating voltage ( $V_{op}$ )	1.2	MV
$Q_0$ at $V_{op}$ (HT)	$>5 \times 10^8$	-
RF power	190	kW
Loaded Q	$5 \times 10^4$	-

# 166MHz SRF cavities for electron acceleration

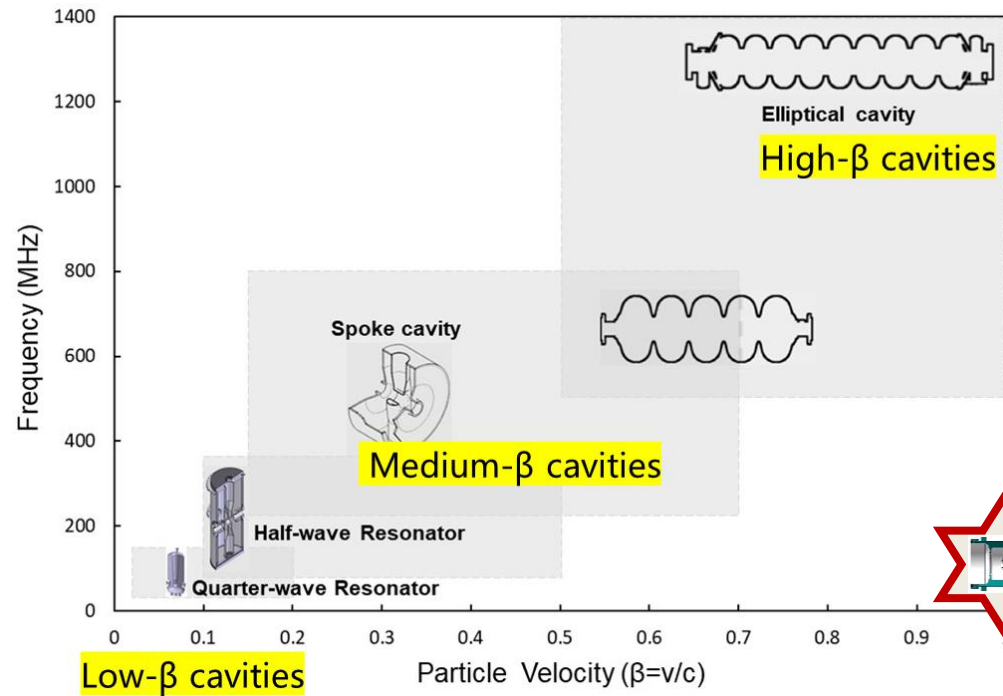

**β=1 elliptical cavities**

2.6GHz   1.3GHz   500MHz   L=2m, Φ1.4m   200MHz

Elliptical cavity length:  $\sim \beta \lambda = \beta \frac{c}{f}$

- Elliptical cavity of 166.6 MHz becomes prohibitively large ( $\lambda$  of 166.6MHz:  $\sim 1.8\text{m}$ )

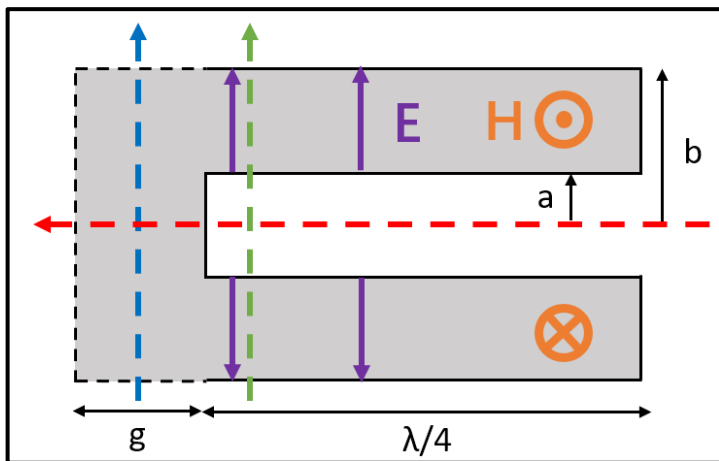

- QWR: unconventional acceleration path
- New application of SC QWRs as main acc. cavities

→ Low-β QWR

→ Crab cavity

→ 166MHz β=1

First of its kind

New development

# 166MHz SRF cavities: new development

- **First of its kind in the world:** low-frequency,  $\beta=1$ , high input power, heavy HOM damping, quarter-wave structure, compact geometry -> **require new design**
- In-house, two-step approach, **9 years of continuous development**
- A total of 8 bare cavities and 5 jacketed cavities produced and tested, met specifications

## Proof-of-Principle (PoP) cavity, 2016-2019, demonstrate prod. technics and surface treatment

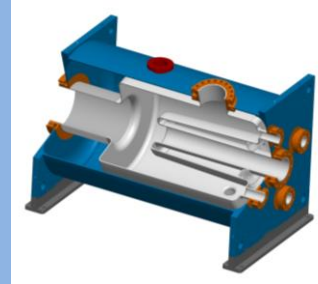
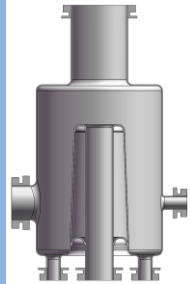
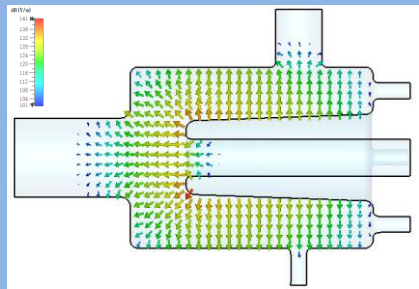

- **Optimization proposed**
  - Repl. pin pickup w/ loop
  - Elongate FPC Nb tube
  - Improve FPC cooling
  - Strengthen HPR ports

## HOM-damped cavity, 2019-2025, prototyping of complete module prior to series production

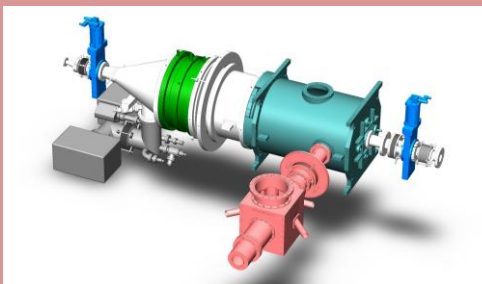
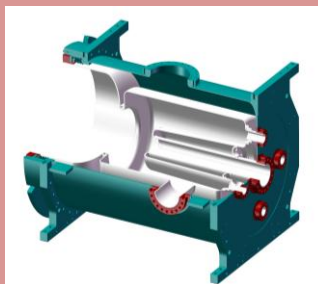
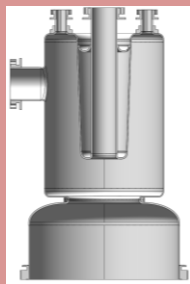
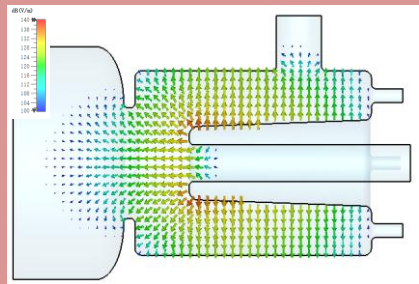

[1] P. Zhang *et al.*, *Rev. Sci. Instrum.* 90, 084705 (2019). [2] L. Guo *et al.*, *Rev. Sci. Instrum.* 95, 074702 (2024).

# Cavity RF design

- RF design focused on manageable cavity size, minimized peak fields
- A slope on inner conductor cone (2.07°) to improve LHe flow & increase HOM frequencies for HOM extraction and damping
- Quantity and location of ports optimized to ensure HPR efficacy and geometry integrity

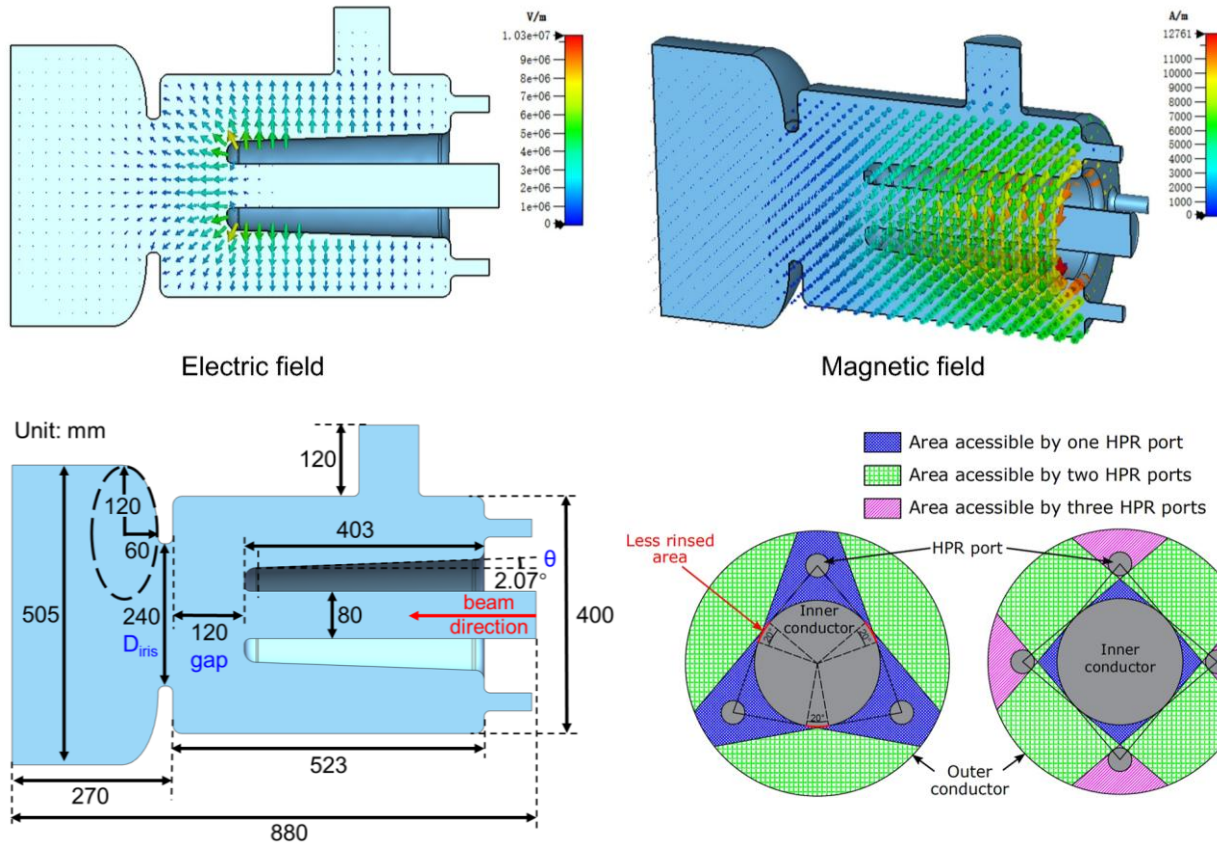

TABLE II. Rf parameters of the 166.6 MHz HOM-damped cavity.

Parameter	Value	Unit
Frequency	166.6	MHz
Operating voltage $V_{op}$	1.2	MV
Designed voltage $V_d$	1.5	MV
Designed gradient $E_{acc}$	12.5	MV/m
Peak surface electric field $E_p$ at $V_d$	39.7	MV/m
Peak surface magnetic field $B_p$ at $V_d$	62.1	mT
$B_p/E_p$	1.56	mT/(MV/m)
Stored energy $U$	15.6	J
$R/Q (= V ^2/\omega U)$	138.9	$\Omega$
Geometry factor $G (=R_s \cdot Q_0)$	56.1	$\Omega$

[1] P. Zhang *et al.*, *Rev. Sci. Instrum.* 90, 084705 (2019).

[2] L. Guo *et al.*, *Rev. Sci. Instrum.* 95, 074702 (2024).

# RF design: HOM damping options

Petal + HOMC

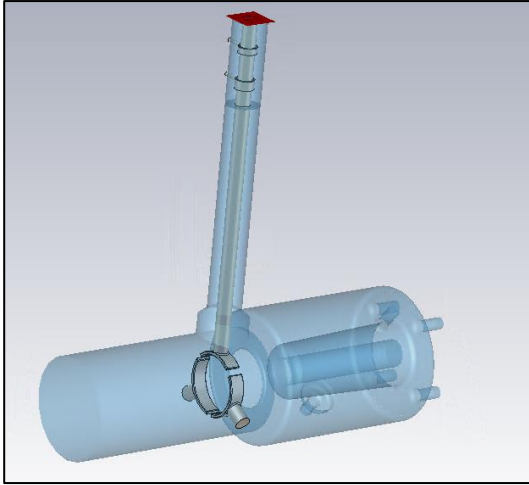

CWG + FPC

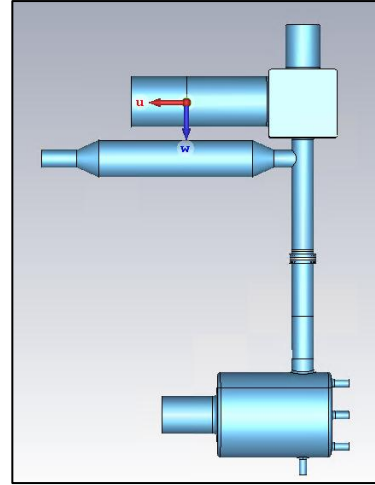

CWG

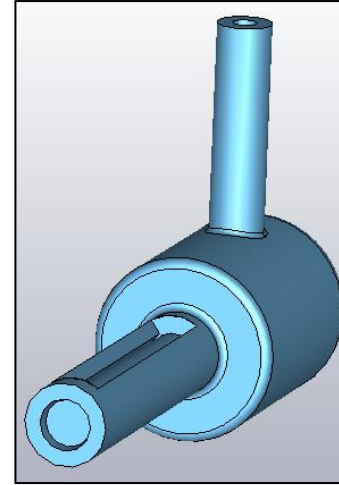

Damper + HOMC

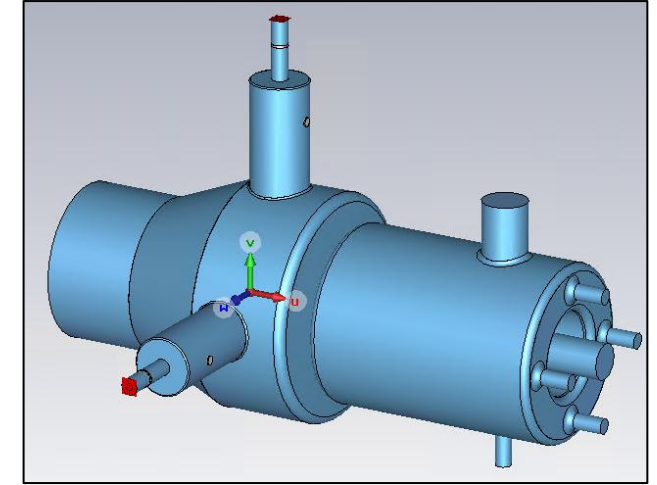

RT beamline absorber (LBP)

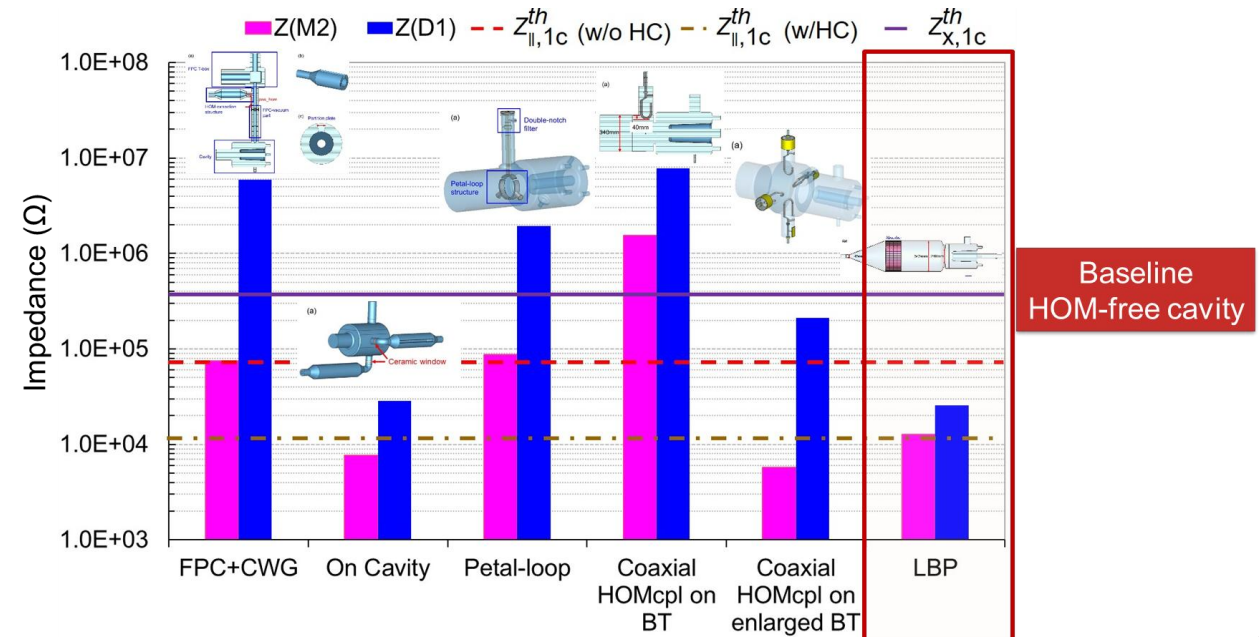
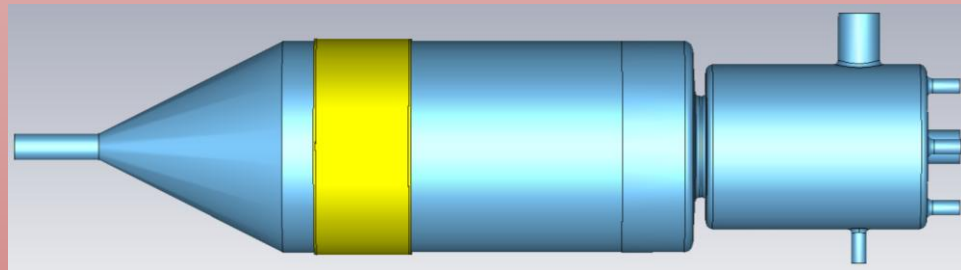

H. Zheng *et al.*, *IEEE Trans. Appl. Supercond.* 34, 3500309 (2024).

# RF design: HOM damping

All HOMs satisfy the impedance requirements.

Parameter	High charge	High brightness
Bunch rms length (mm)	5.06	5.06
$k_{HOM}$ (V/pC)	2.54	2.54
Beam current (mA)	200	200
Bunch number	63	680
Bunch charge (nC)	14.41	1.33
Average HOM power (kW)	<b>7.32</b>	0.68

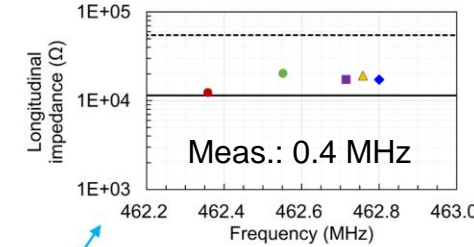
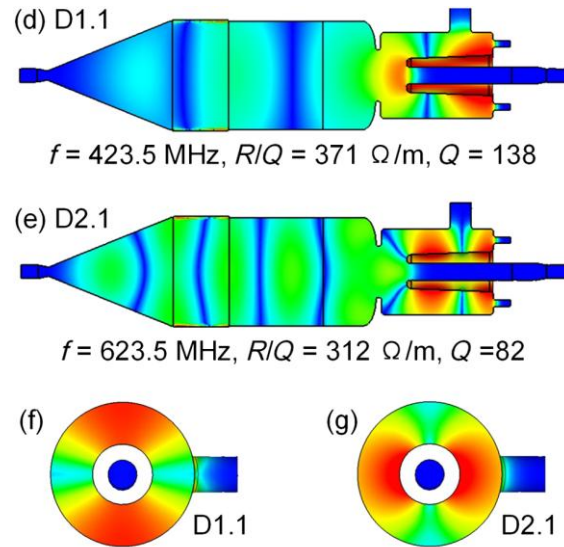
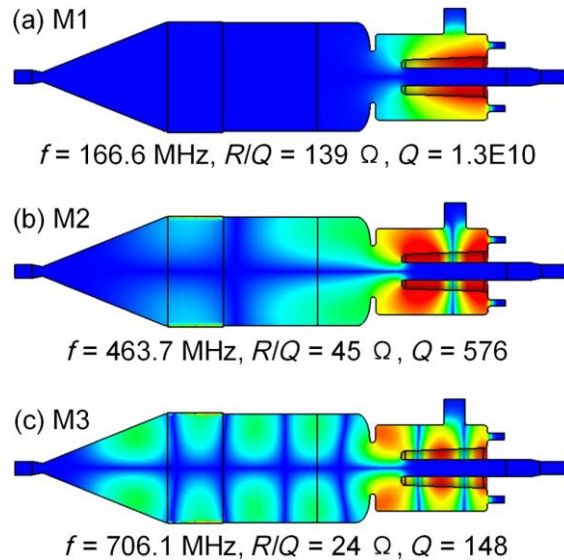

0.2 MHz freq. spread will increase the  $Z_{//}$  threshold by 1.7 times

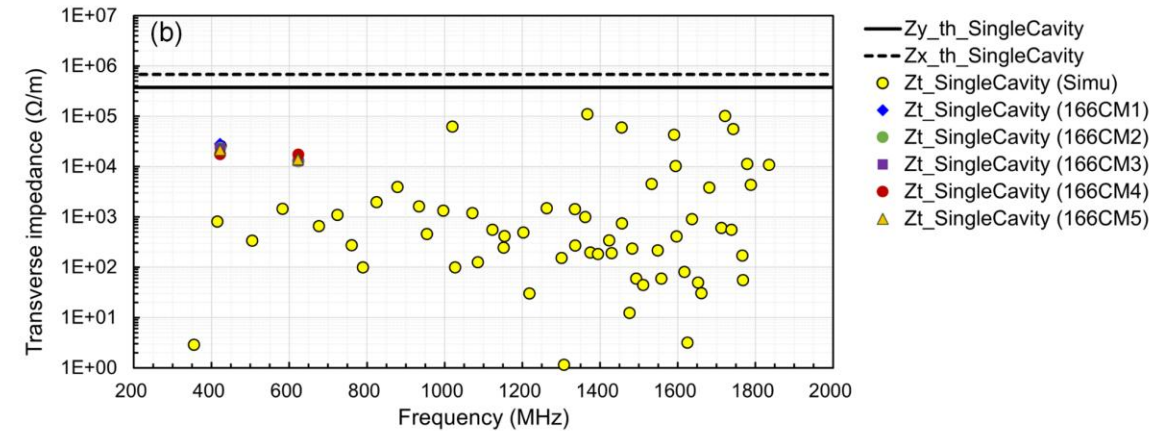
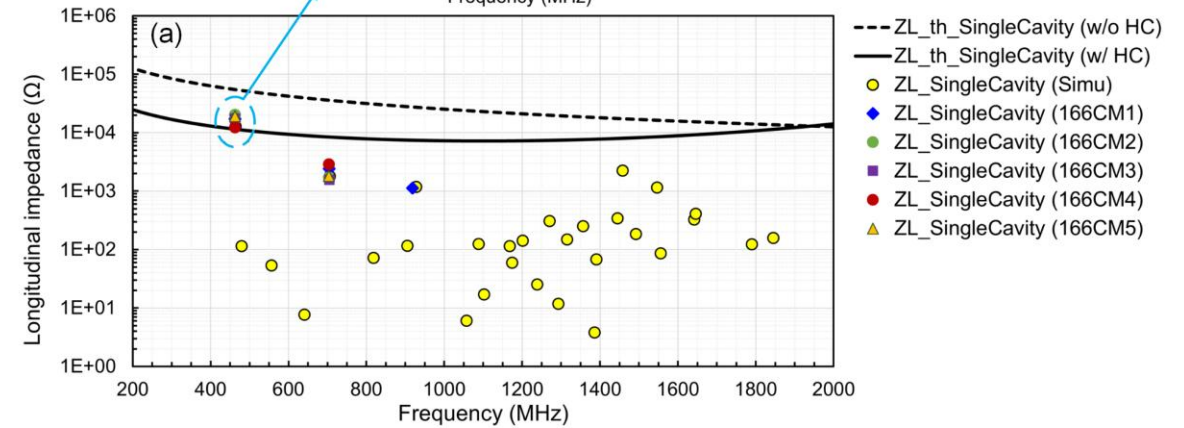

[1] H. Zheng *et al.*, *IEEE Trans. Appl. Supercond.* 34, 3500309 (2024).  
 [2] P. Zhang *et al.*, *Phys. Rev. Accel. Beams* 29, 032002 (2026).

# RF design: Multipacting

- Three soft MP bands, easy to clean by RF conditioning during VT and HT

Normalized SEY curves after different surface treatments

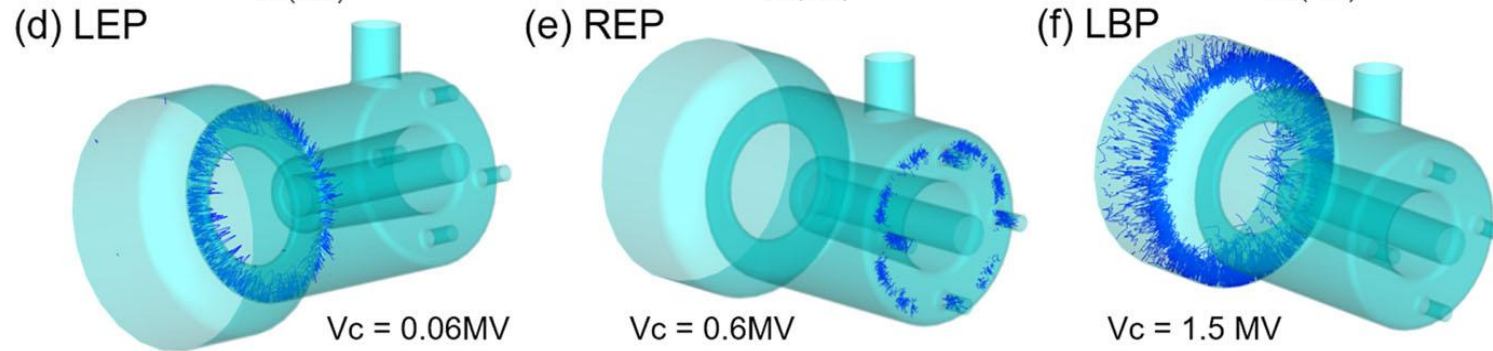
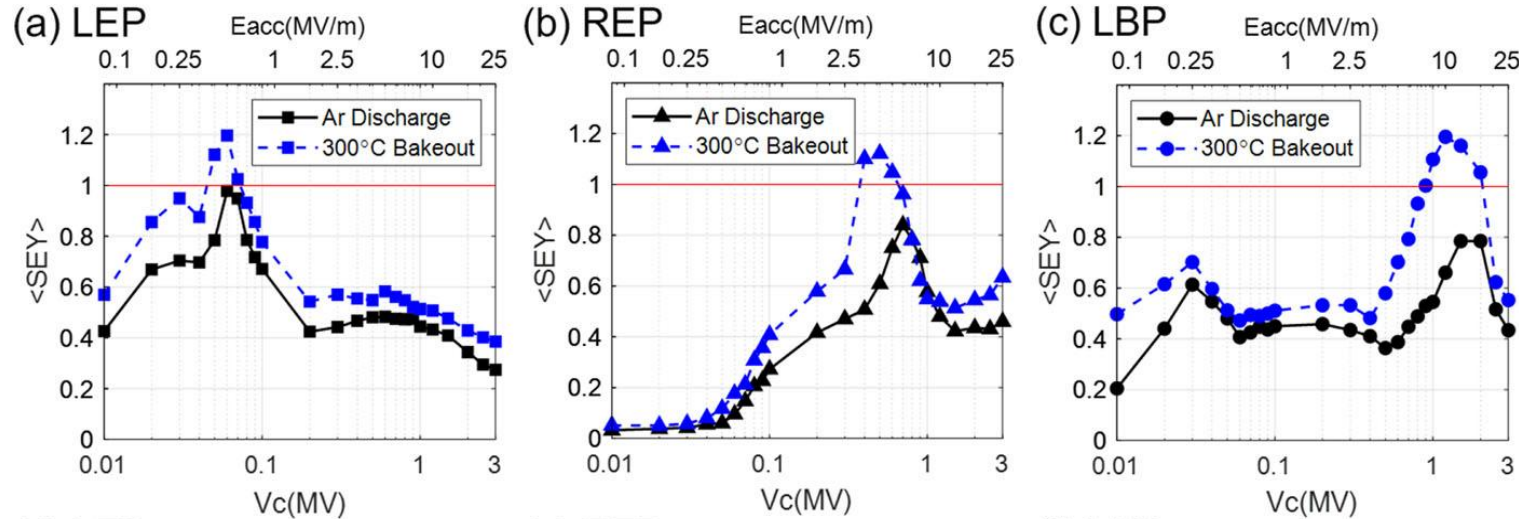

MP during VT compared with simulation

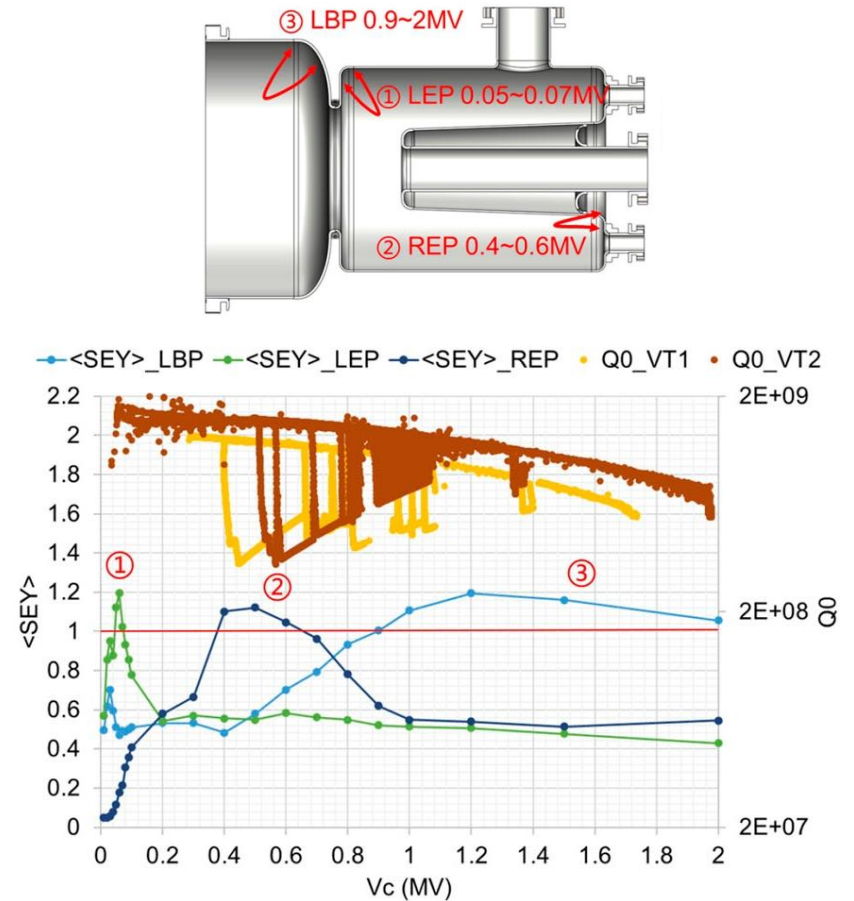

[1] L. Guo *et al.*, *Rev. Sci. Instrum.* 95, 074702 (2024).

[2] L. Guo *et al.*, *JINST* 16, P11003 (2021).

# Cavity mechanical design

- **Design challenges introduced by LBP enlargement (170 mm -> 505 mm)**
  - Low gap tuning sensitivity (reduced capacity due to large iris of 240mm)
  - Excessive tuning stiffness: large bellows required
  - Significantly increased peak stress: optimize cavity geometry, add stiffeners & supports

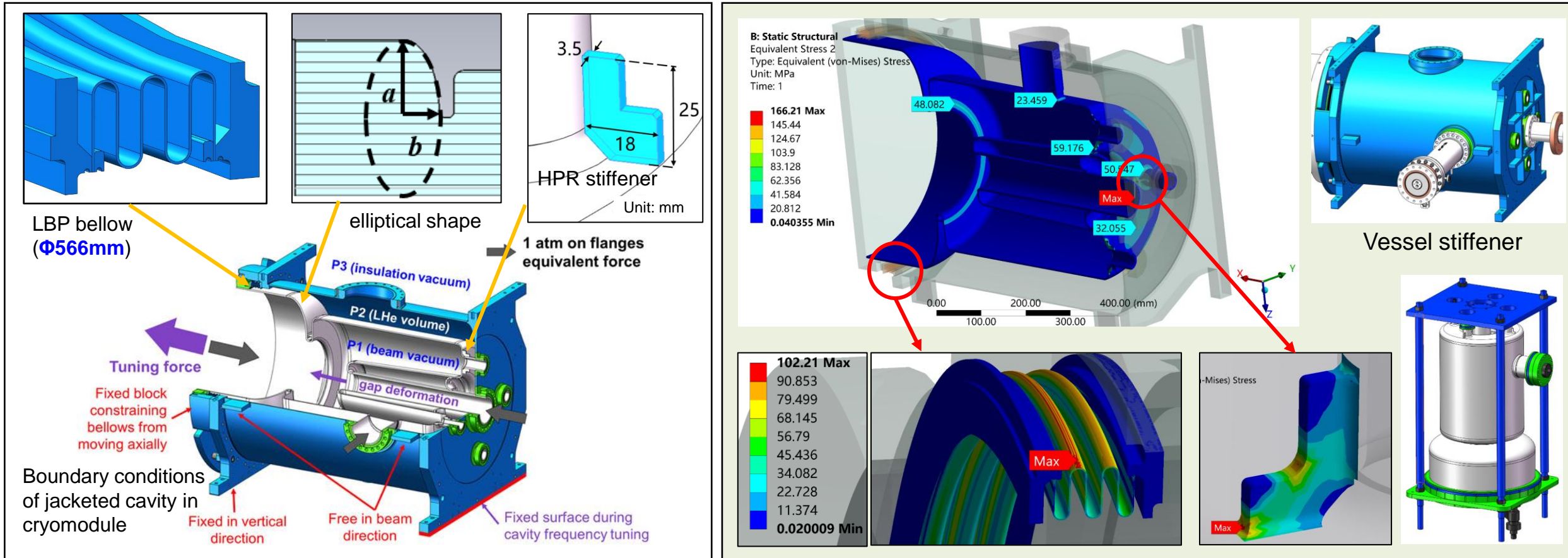

# Cavity mechanical design

- In all working conditions, the stress on cavity/string meet safety requirements
- All mechanical parameters satisfy design specifications

\* Freq. shift from He pressure < 5% BW  
 \*\* Lorentz detuning freq. shift < 1% tuning range

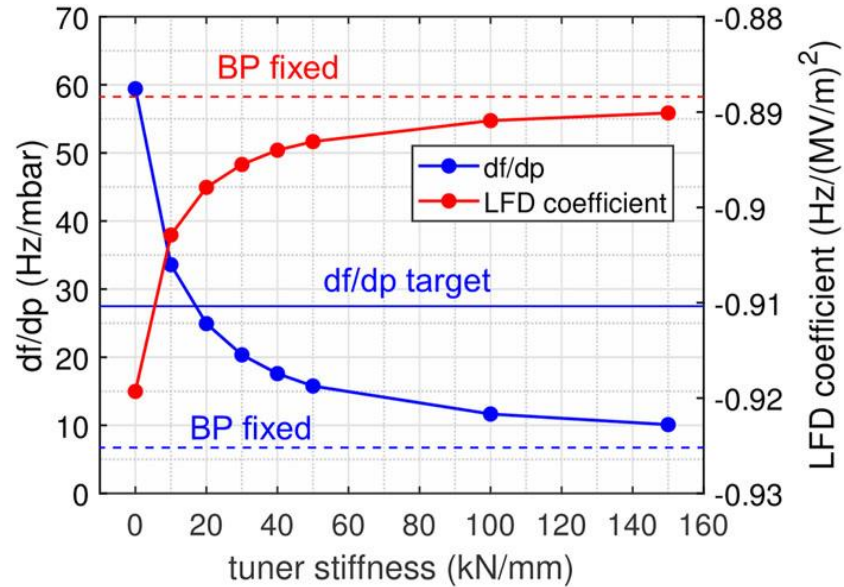

Buckling

Type: Total Deformation  
 Load Multiplier (Linear): 11.616  
 Unit: mm

1 Max  
 0.88889  
 0.77778  
 0.66667  
 0.55556  
 0.44445  
 0.33334  
 0.22222  
 0.11111  
 0 Min

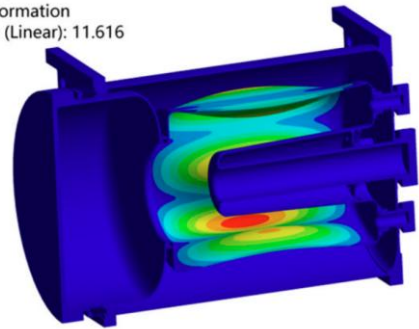

Microphonics: >100Hz

Type: Total Deformation  
 Frequency: 108.2 Hz  
 Unit: mm

14.634 Max  
 13.008  
 11.382  
 9.7562  
 8.1302  
 6.5042  
 4.8781  
 3.2521  
 1.626  
 0 Min

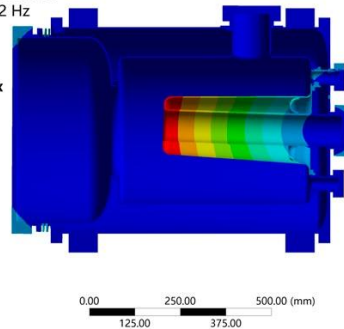

Parameter	Condition	Value	Spec.	Unit
Tuning sensitivity	/	34.1		kHz/mm
Tuning stiffness	/	9.4	<10	kN/mm
Tuning range at 4 K	/	0-76.6		kHz
Tuning force at 4K	/	0-19.3		kN
Pressure sensitivity	BPs fixed	6.7	<27.5*	Hz/mbar
	Kt=30kN/mm	20.3		
$\Delta f$ ( $\pm 3$ mbar)	BPs fixed	$\pm 20$	<82.5	kHz
	Kt=30kN/mm	$\pm 60.9$		
LFD coefficient	BPs fixed	-0.89	<5**	Hz/(MV/m) <sup>2</sup>
	Kt=30kN/mm	-0.90		
LFD at $V_d$ (1.5 MV)	BPs fixed	-114	<781	Hz
	Kt=30kN/mm	-139		

# Cavity fabrication

- **Strict quality control implemented**

RF surface: 1.72 m<sup>2</sup>

- Nb material inspection, RF surface quality management, welding deformation correction



# Cavity surface treatment

- Established BCP recipes for bare cavities, no chemistry required for jacketed cavities, all ports protected by SS shields during welding → **VT performance: jacketed cavity = bare cavity**

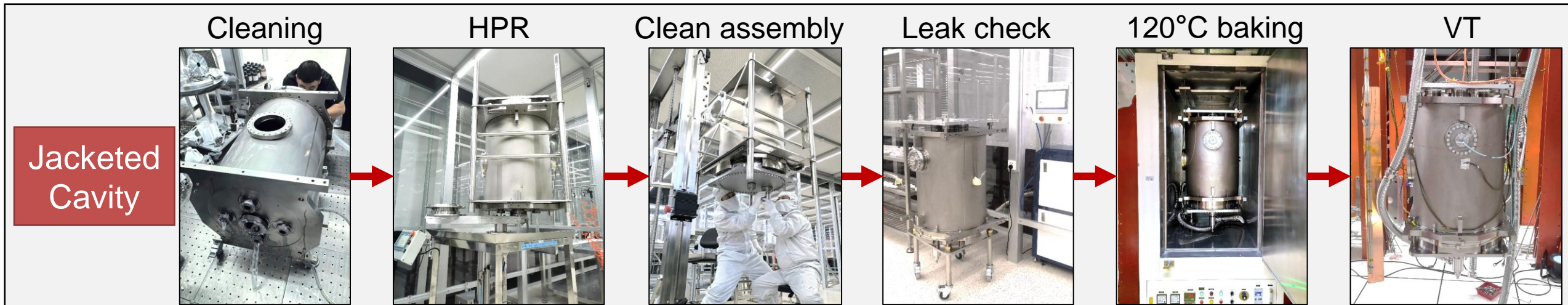
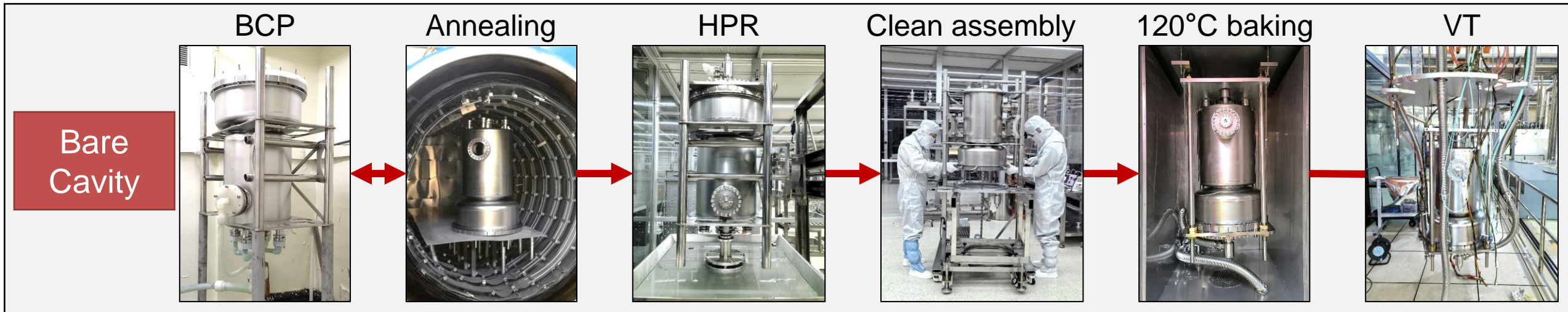

# BCP improvement

- Enlarged LBP leads to extreme diameter ratio (max/min ~17x), significantly affecting acid flow direction and distribution, making uniform etching difficult, surface features observed & removed

Issue	Solution
Streak features in LBP transition region	Modified BCP setup to increase acid flow velocity in LBP transition region guided by fluid simulation
Non-uniform cavity etching	Optimize etching time in different orientations, thickness monitoring
Uneven etching amount on right end plate	Increase monitoring points, use cavity inclination angle to fine tune etching uniformity
Air-chamber on FPC port Nb tube	Modify BCP fixture, adjust position of flow guide tube
Acid residue	Wipe or light BCP for 5 minutes

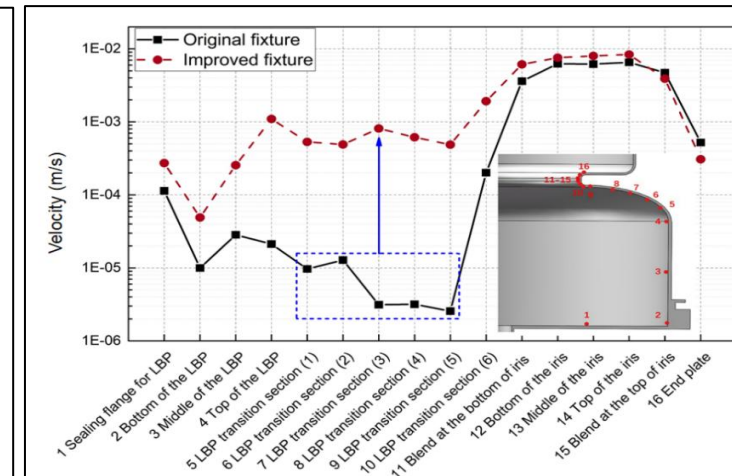
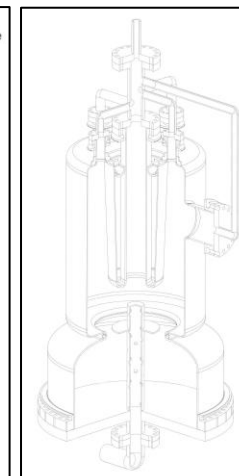
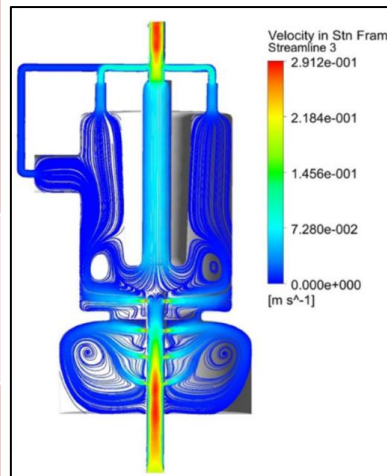
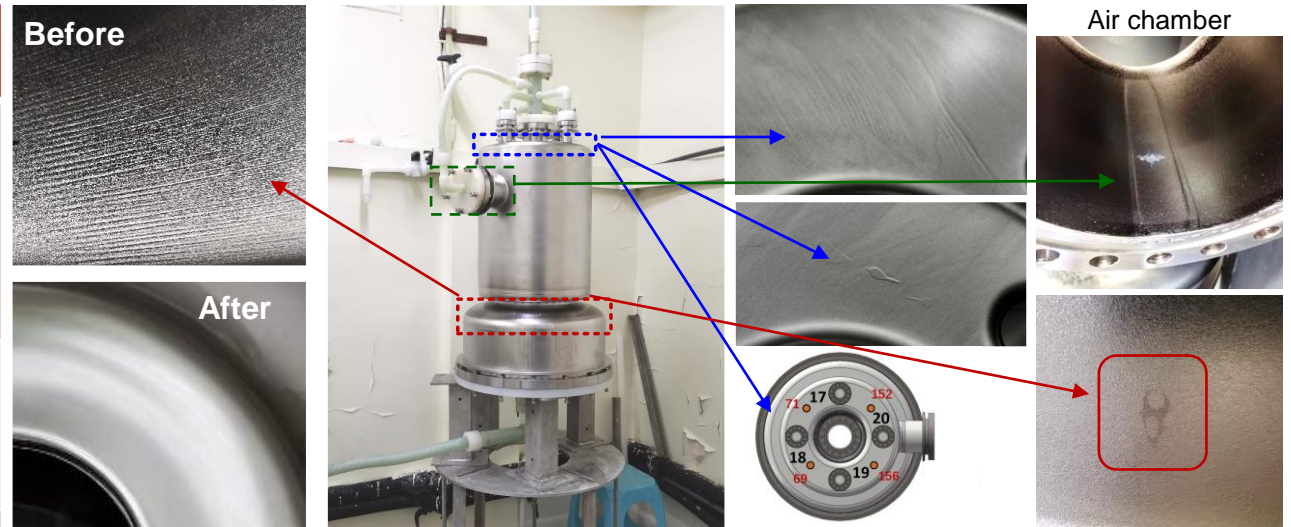

# Cavity vertical tests

- **Excellent cryogenic performance achieved:** optimized procedure ensuring no field-emission onset & considerably reduced multipacting occurrence
- Good performance preserved from bare to jacketed cavities (no chemistry after jacketing)
- **Series cavities outperformed qualification criteria (6 out of 7)**

Vertical test results of 166MHz SRF cavities

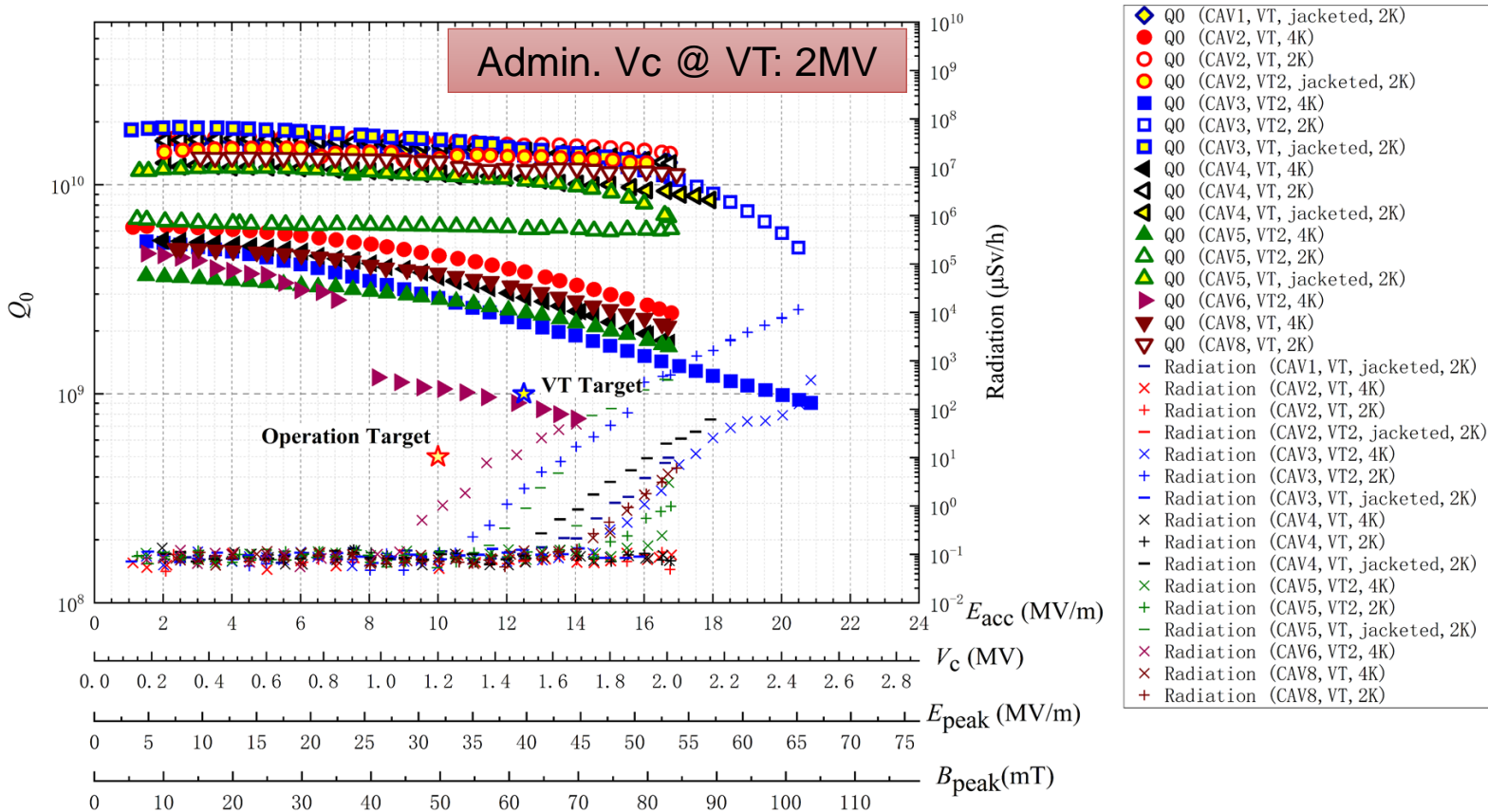

- CAV06: welding defect, degraded cavity performance degraded
- CAV02J: drop dent, **no impact on cavity performance**



Welding defect

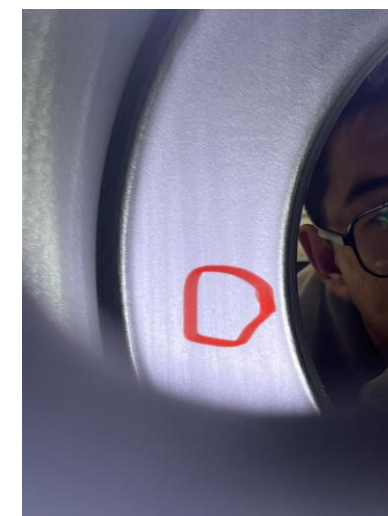

Drop dent

# Single-cavity module or two-cavity module?

- Requirements: avoid direct synchrotron light irradiation on cavity surface, bellows, RF-shielded gate valves; Acceptable loss factor; Interchangeability; Ease of maintenance.

**< 6.086 m**

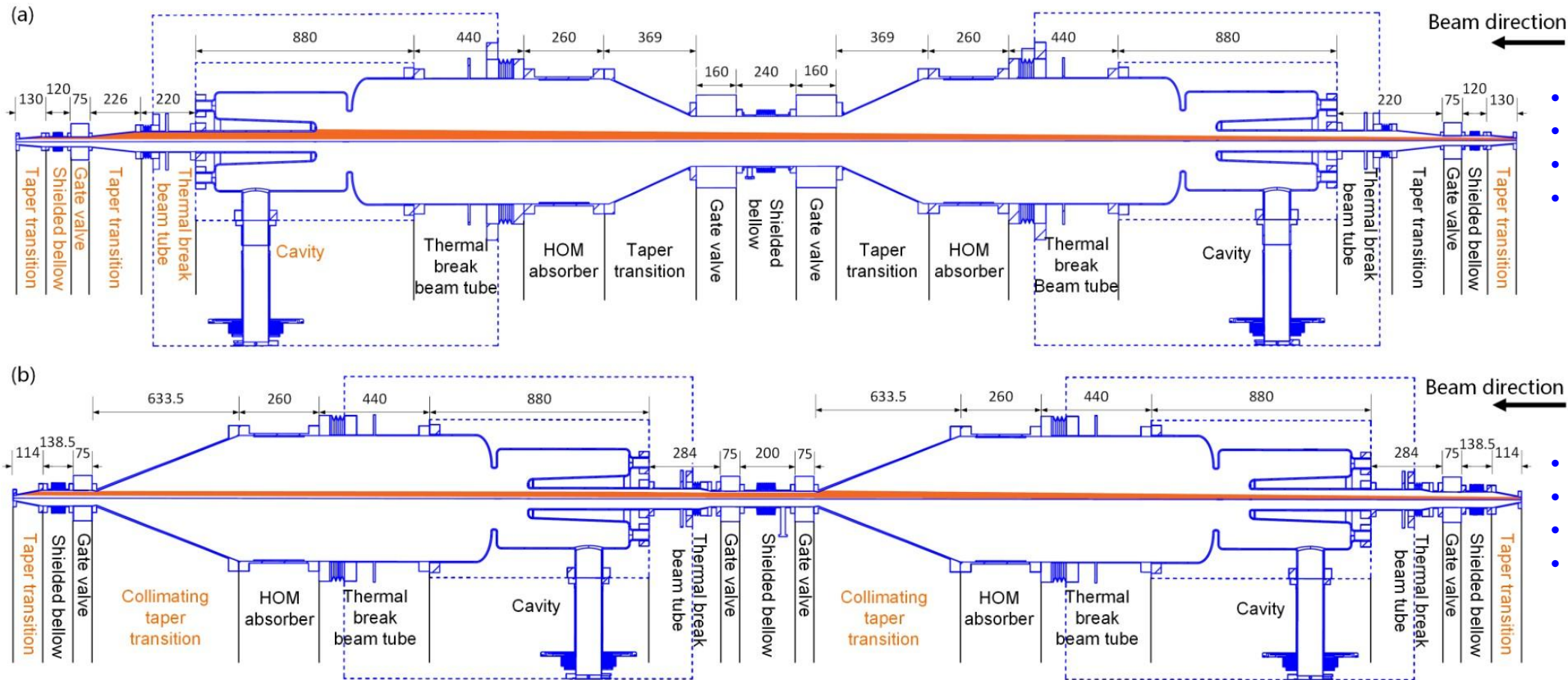

- SR check ✓
- Interchangeability ✗
- Compact ✓
- 3.345 V/Pc ✓

- SR check ✓
- Interchangeability ✓
- Compact ✓
- 5.2 V/Pc ✓



# Cavity string

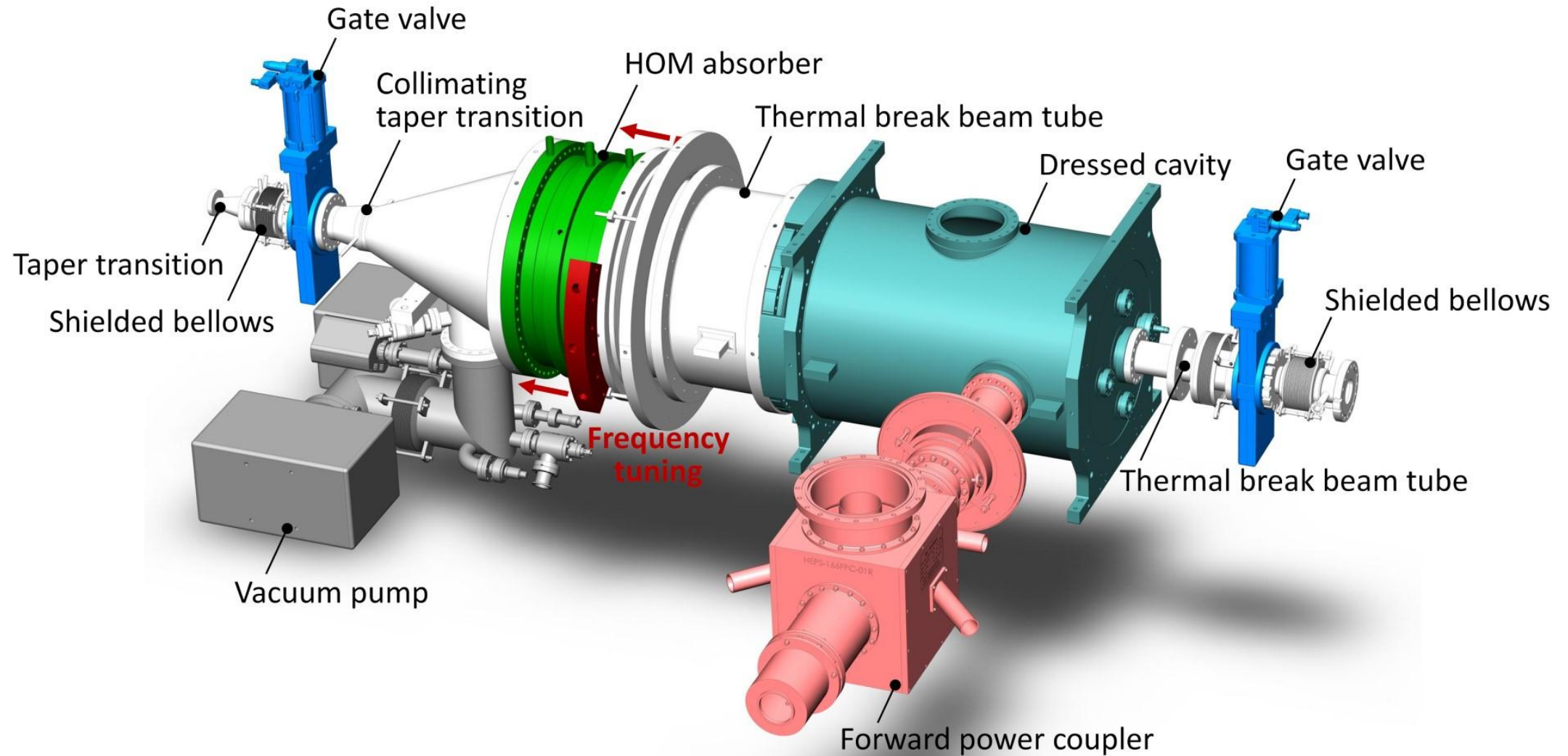

# Ancillaries: fundamental power coupler

Details in T. Huang's talk

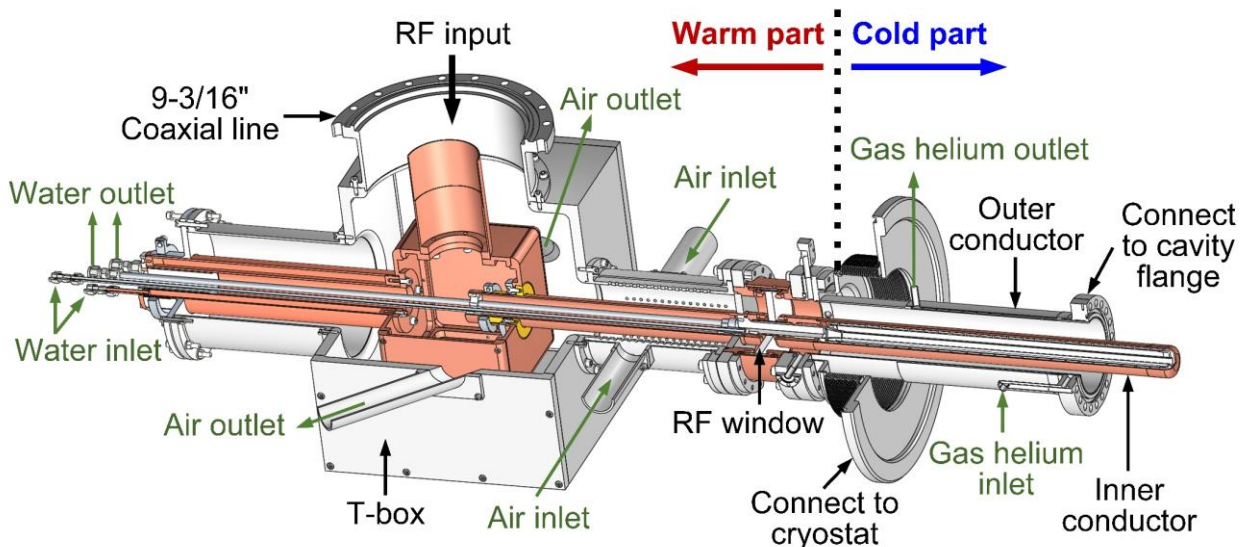

Parameter	Value
Max. power	200 kW (CW)
External Q	$5 \times 10^4$
FPC type	Coaxial, single window
Window type	Coaxial disk with choke
Coupling type	Electric

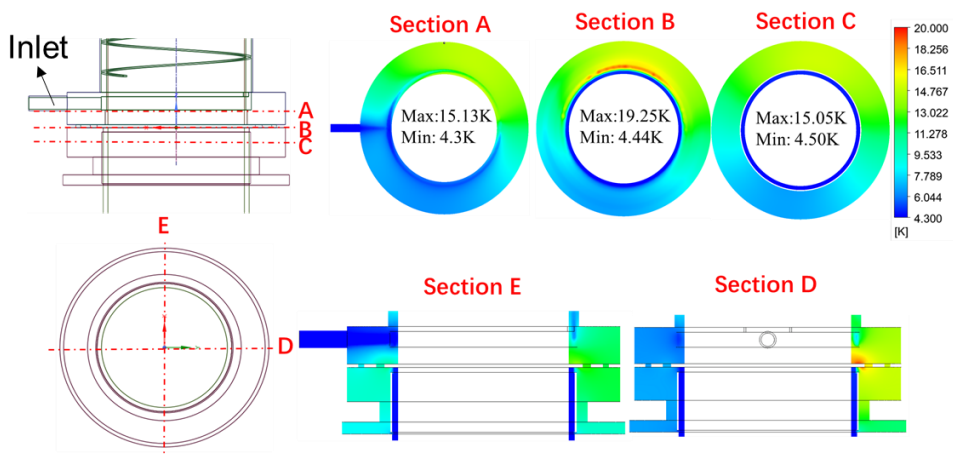

T. Huang et al., *Review of Scientific Instruments* 91, 063301 (2020).

# Cryomodule design

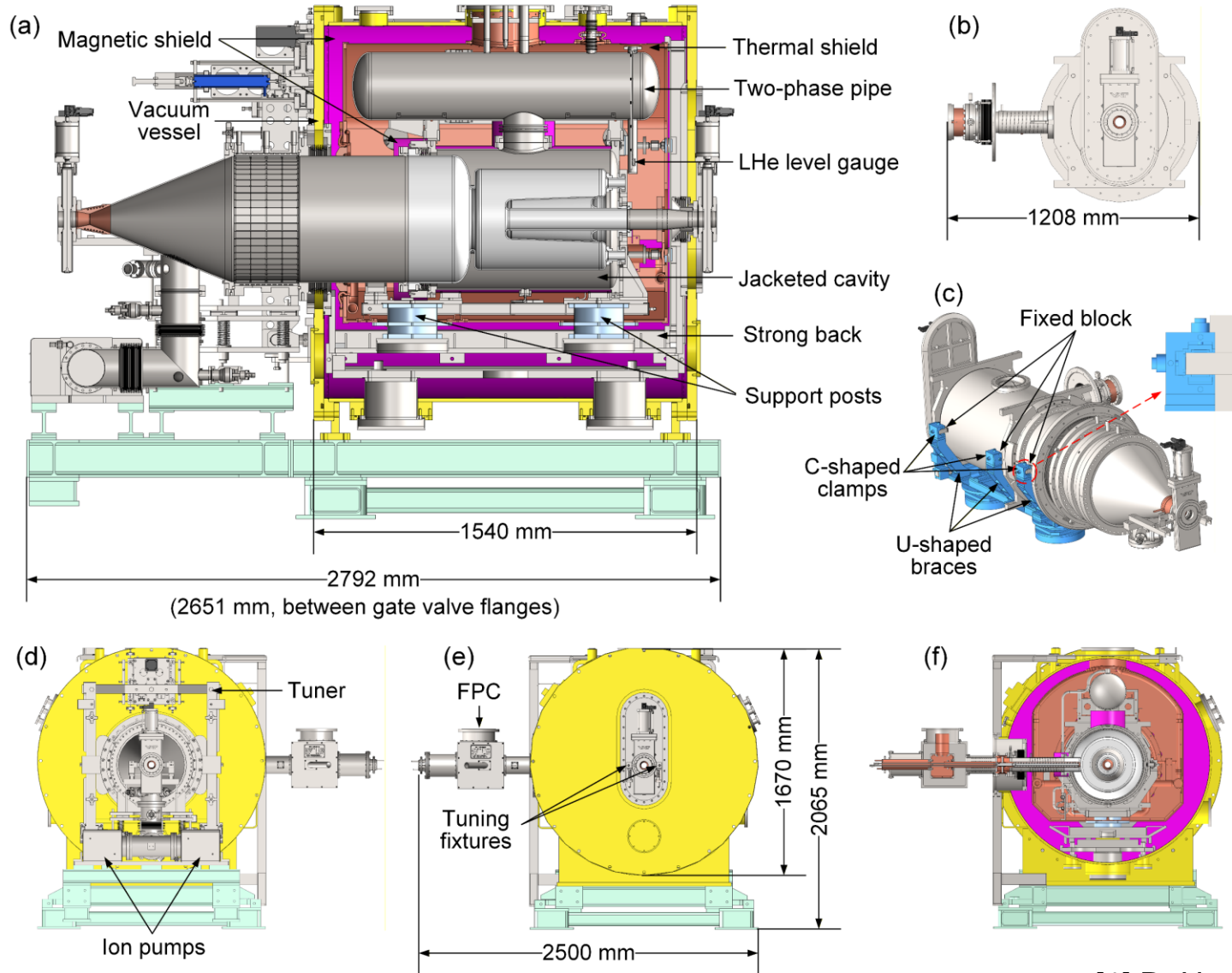

- The cryomodule contains a single 166.6 MHz cavity, operating at 4.2 K
- The LHe volume within the helium jacket is 89 L, and a two-phase pipe is placed on top of the cavity, increasing the total LHe capacity to 157 L
- The LHe supply connects at both the top and bottom of the cavity jacket to stabilize helium pressure during cooldown
- The outer conductor of the FPC is cooled by helium gas evaporating from the LHe vessel, with a regulated flow rate
- The cavity string are supported by three U-shaped braces. C-shaped clamps connect the braces to the fixed blocks, ensuring alignment through adjustable bolts and spring washers

[1] R. Han *et al.*, NIM-A 1070,170000 (2005).

[2] P. Zhang *et al.*, *Phys. Rev. Accel. Beams* 29, 032002 (2026).

# Cavity and module assembly

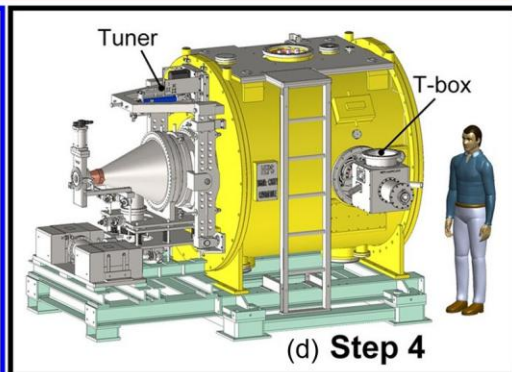
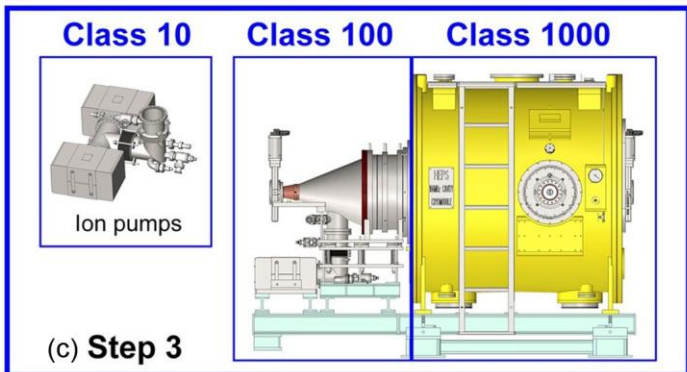
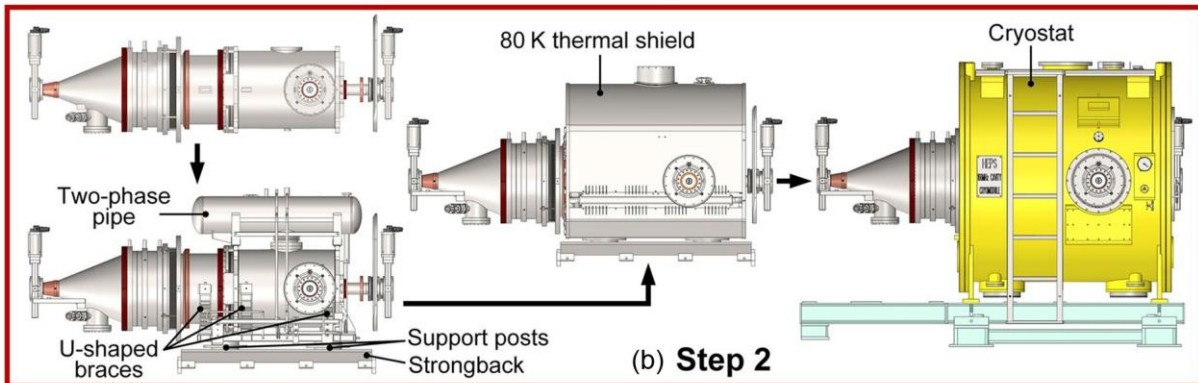
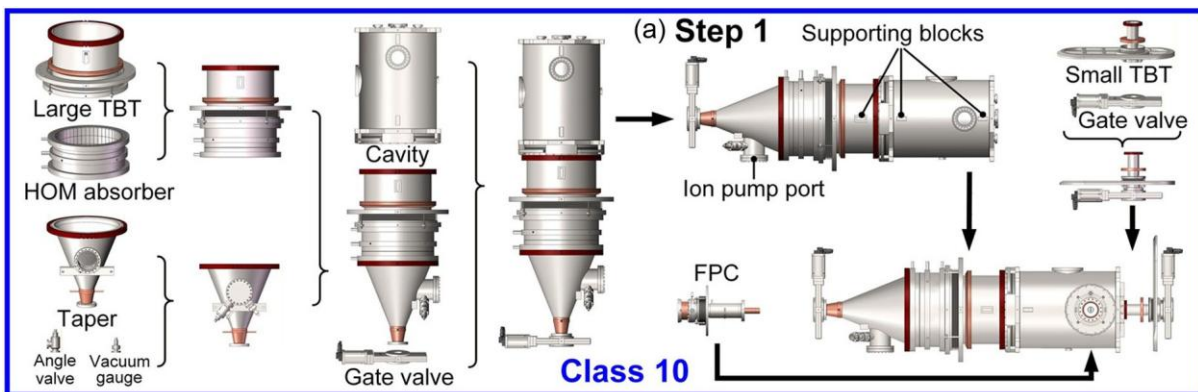

## • The process consists of 4 steps

- ① Assembly of the cavity string in cleanroom
- ② Integration of the cavity string and the cryostat to form an intermediate assembly
- ③ Mounting of the ion-pump group with the intermediate assembly in the cleanroom, thereby finalizing the core module structure
- ④ Installation of the tuner and FPC's T-box onto the resultant structure.

Following these steps, a full module is constructed

## • Advantages of the design & process

- Requires only **one vacuum break**
- Sealing port **located far from the cavity and oriented downward** to minimize contamination during final assembly

# Cavity string assembly

- Due to **large diameters**, **complex structure**, and **significant weight**, the clean assembly posed **unprecedented challenges** regarding vacuum sealing, cleanliness, and precision
  - Entire process conducted in class 10 cleanroom
  - Aluminum alloy 6082-T6 gaskets, developed in-house, used throughout the beamline assembly
  - All large-aperture components were assembled vertically using a custom-built multi-directional adjustable fixture and a large heavy-duty forklift

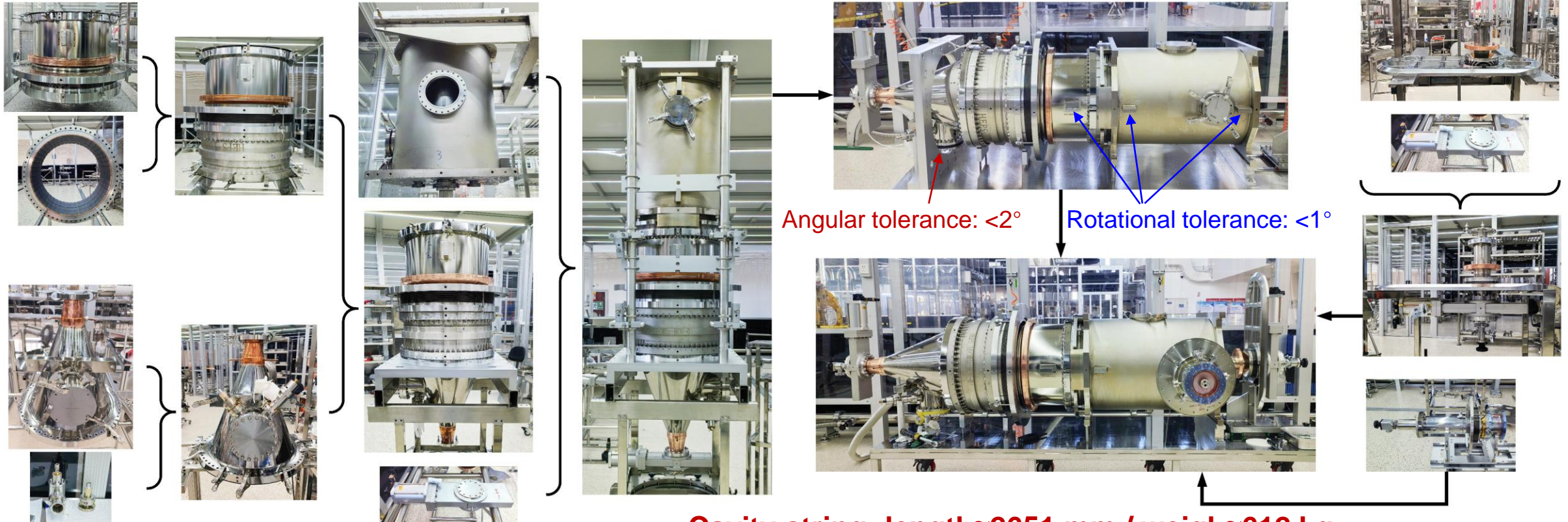

**Cavity string: length $\approx$ 2651 mm / weigh $\approx$ 612 kg**

# Integration of cavity string and cryostat

- HOM absorber was baked first for over 48 h, followed by cavity string at 120°C for 48 h
- Cavity string transferred to the strongback and alignment performed between the cavity string and cryostat's vacuum vessel ( $\pm 1.5\text{mm}$  in trans. dir. &  $\pm 1.0\text{mm}$  in beam axis &  $\leq 1\text{mm}$  offset for FPC)
- Various sensors, cryogenic pipelines, magnetic shielding, and thermal shielding were installed
- The cold mass was moved into the vacuum vessel, and the end plates were mounted
- A leak check of the vessel and the cryogenic pipeline then followed

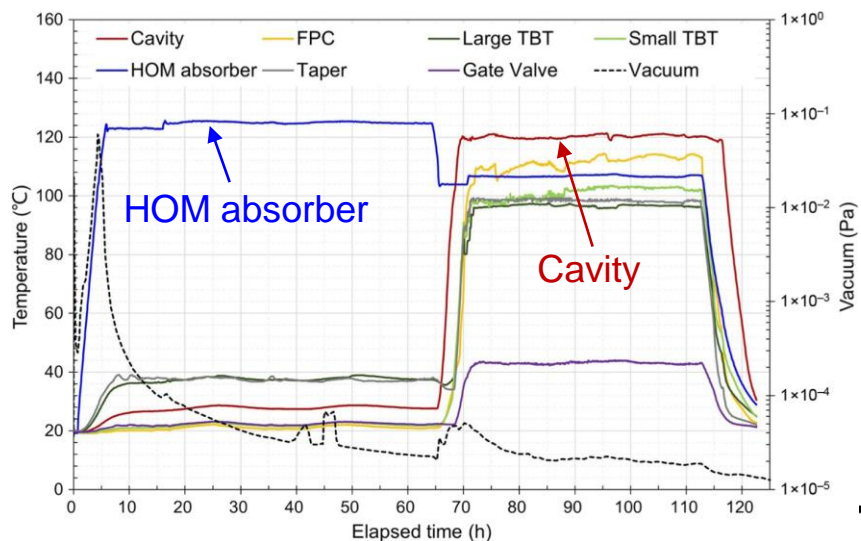

Temperature readings and vacuum pressure of the cavity string during baking

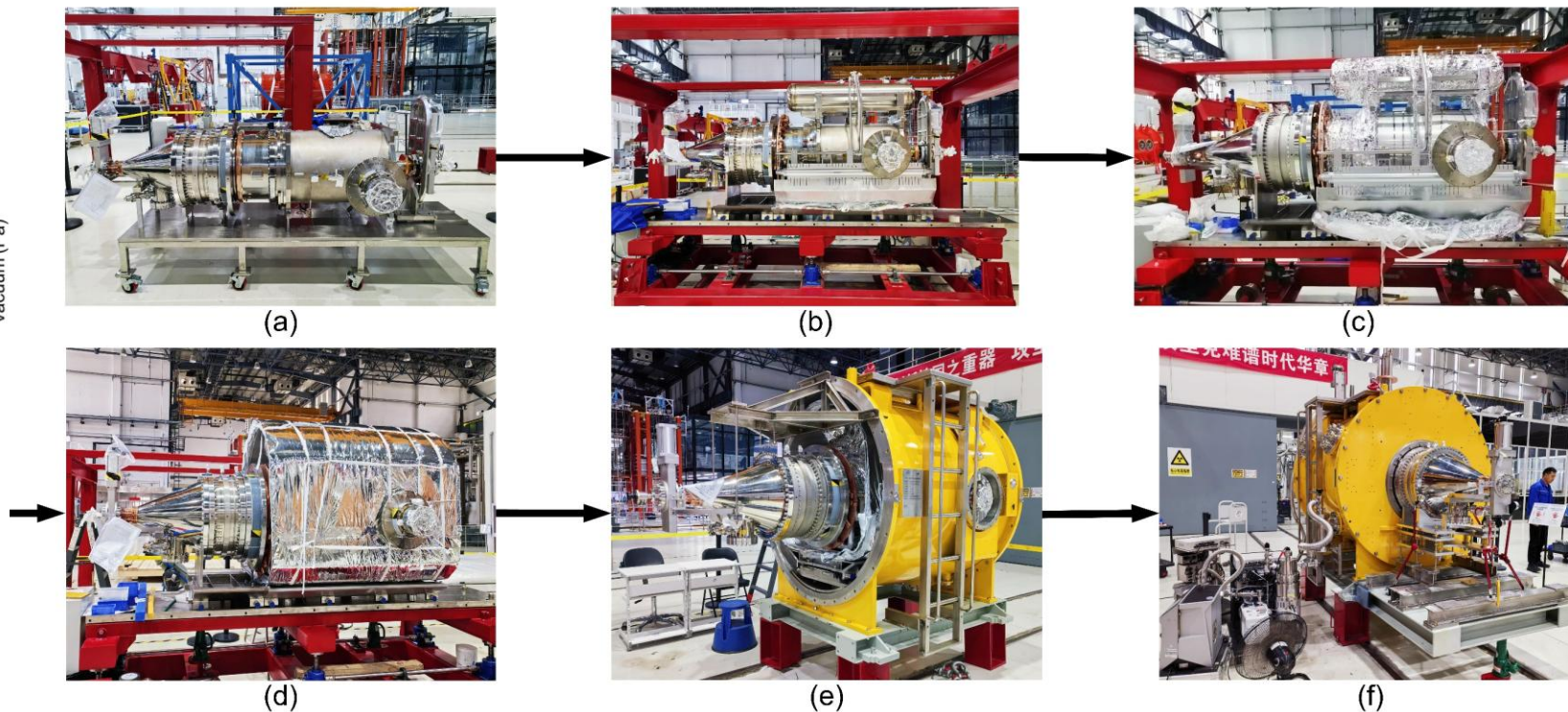

# Integration of ion-pump group, tuner, FPC T-box

- Ion-pump group assembled in class 10 cleanroom
- Cryomodule was integrated with the ion-pump group in class 100 cleanroom
- After a leak check, the module was moved out of the cleanroom for tuner installation
- Finally, the module was transferred to the horizontal test stand (HTS) and the T-box of FPC was installed

class 10

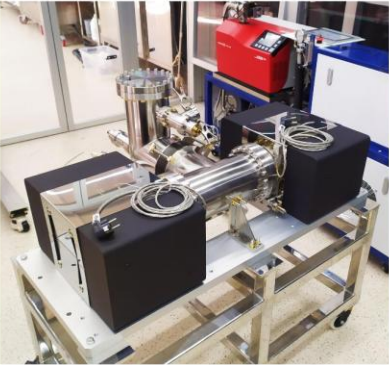

class 100

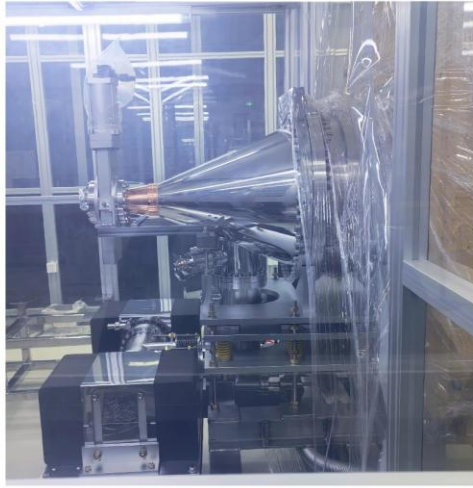

# Module cooldown at HTS

- The HTS was equipped with a 260 kW SSA, a 300 kW circulator and a LLRF control system
- **Cooldown requirement:  $\Delta T_{\max} < 10$  K & maximum cooldown rate  $< 5$  K/h**
  - These limits were specified to preventing vacuum leaks induced by **excessive thermal stress**
- Entire cooldown process lasted 7~11 days, maintaining an average cooldown rate of 1.1~1.7 K/h

HTS for 166.6 MHz cryomodules

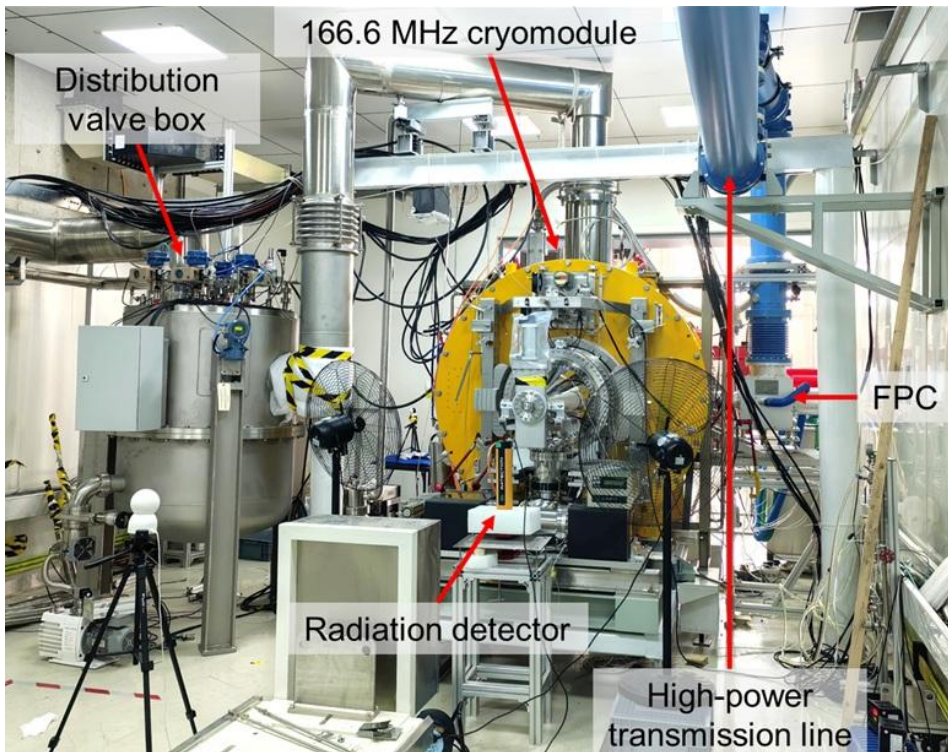

Time consumption for RF conditioning at HTS and in the HEPS tunnel

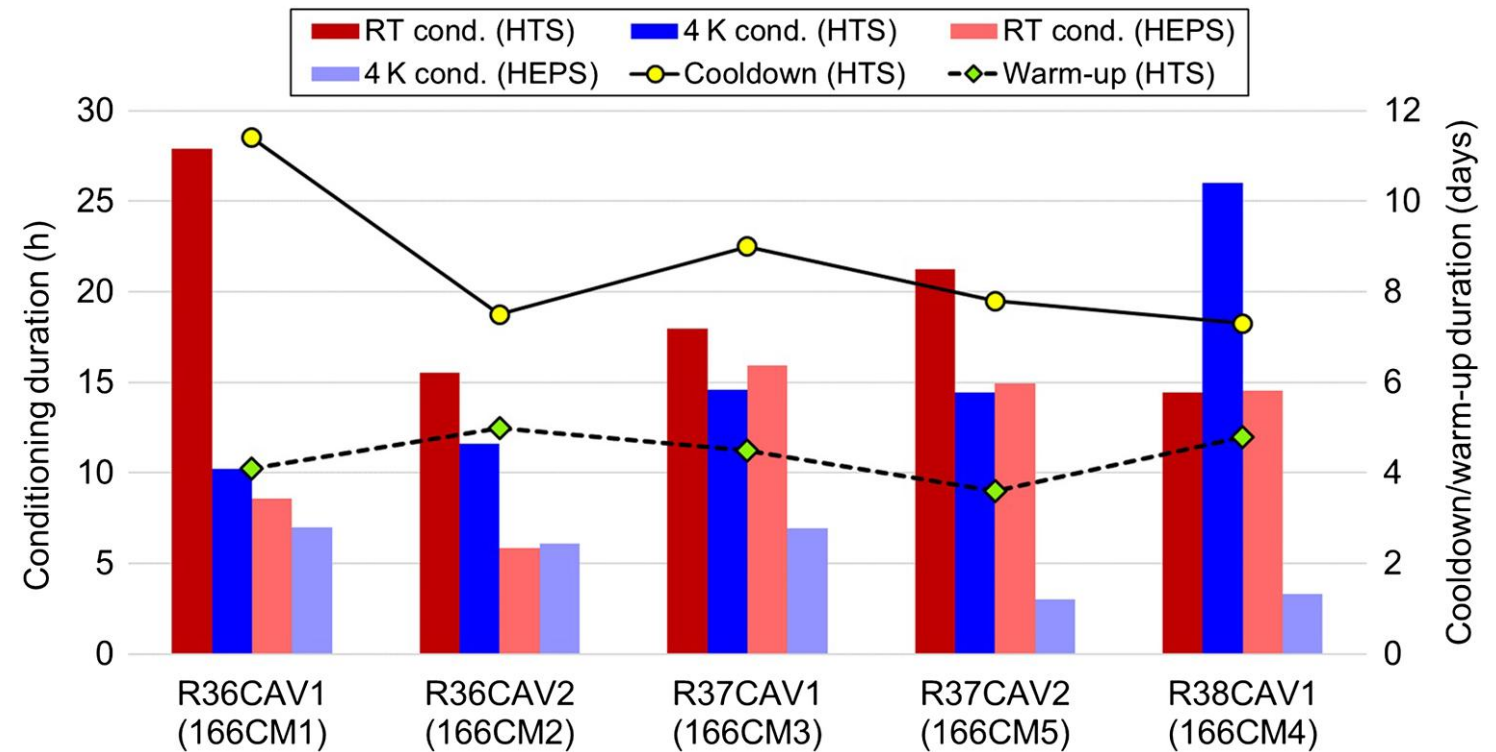

# Cavity conditioning at HTS (RT and 4.2 K)

- **Conditioning at room temperature**

- Up to 110 kW with the frequency detuned by 400 kHz to process the rf surface of the FPC
- Outgassing due to multipacting of FPC, ranging from 1 to 5 kW, consistent with simulations

- **Conditioning at 4.2K**

- Cavity tuned to 166.6 MHz, process RF surfaces of both the cavity and the FPC
- Multipacting bands of the cavity were easily cleaned by RF power
- Following 10 to 26 hrs of RF conditioning, all cavities successfully reached 1.6 MV, exceeding the design voltage of 1.5 MV

RF conditioning at room-temperature

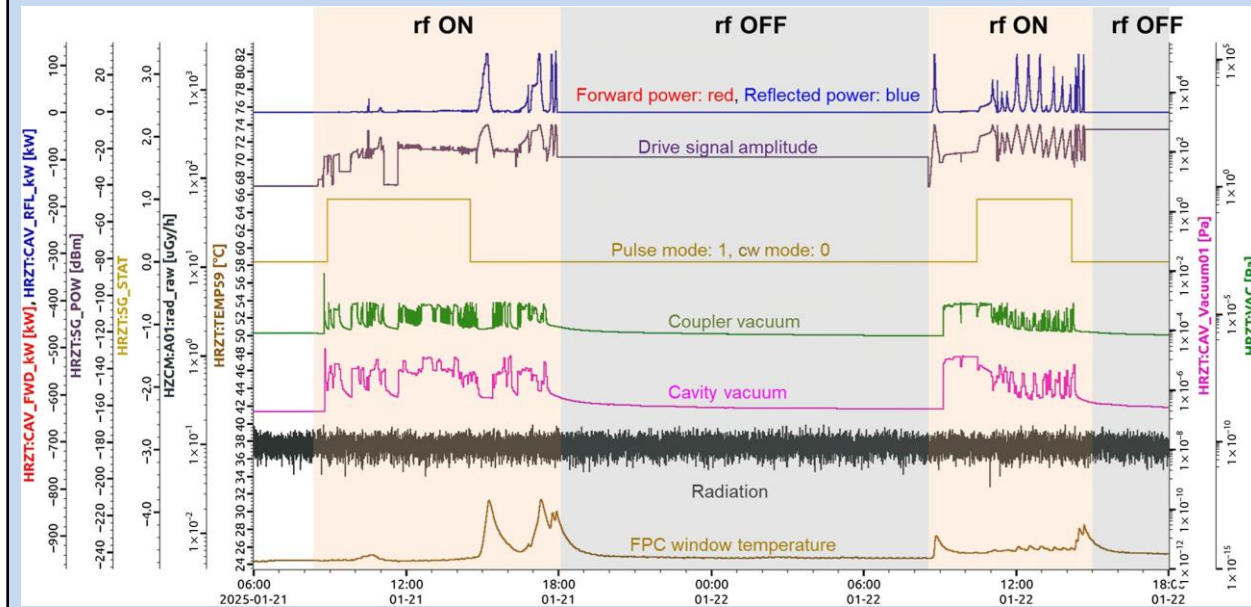

RF conditioning at 4.2K

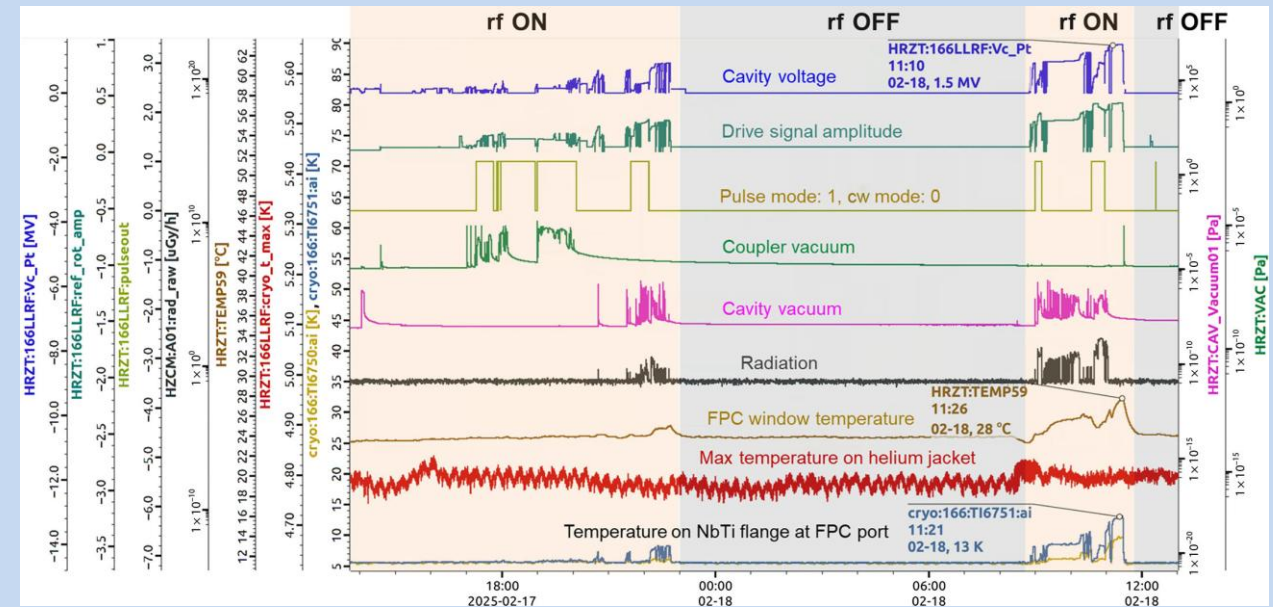

# Performance of 166 MHz SRF modules

Parameter	Spec.	Test	Unit
Vc_op	≥ 1.2	1.5~1.6	MV
Q <sub>0</sub> @ Vc_op	≥ 5e8	1.5~2.1e9	-
Radiation @ Vc_op	< 500	0.08~84	μSv/h
Static HL @ 4K	< 40	33~36	W
Dynamic HL @ 4K	< 21	5~7	W

166MHz cavities & CMs: HT and VT results at 4K

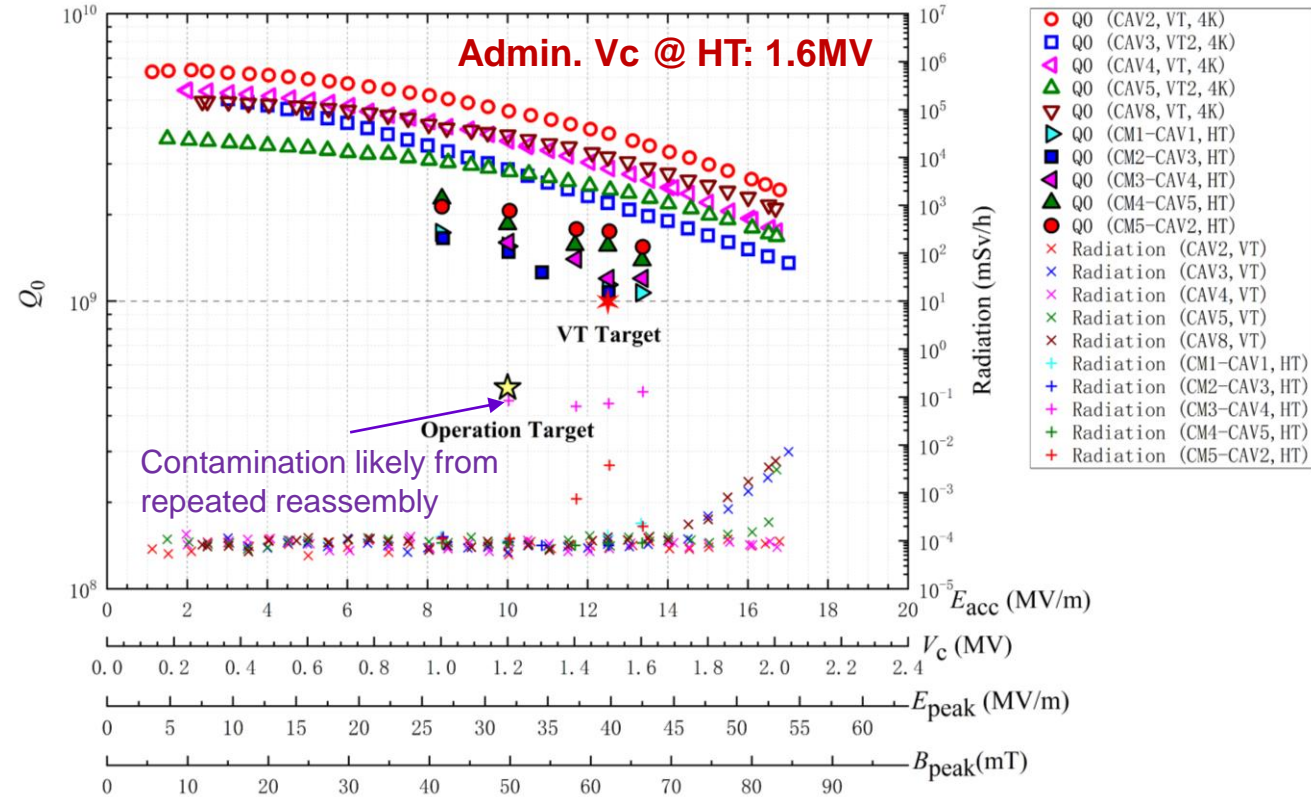

Calibrate the cryogenic heat load with the helium boil-off rate

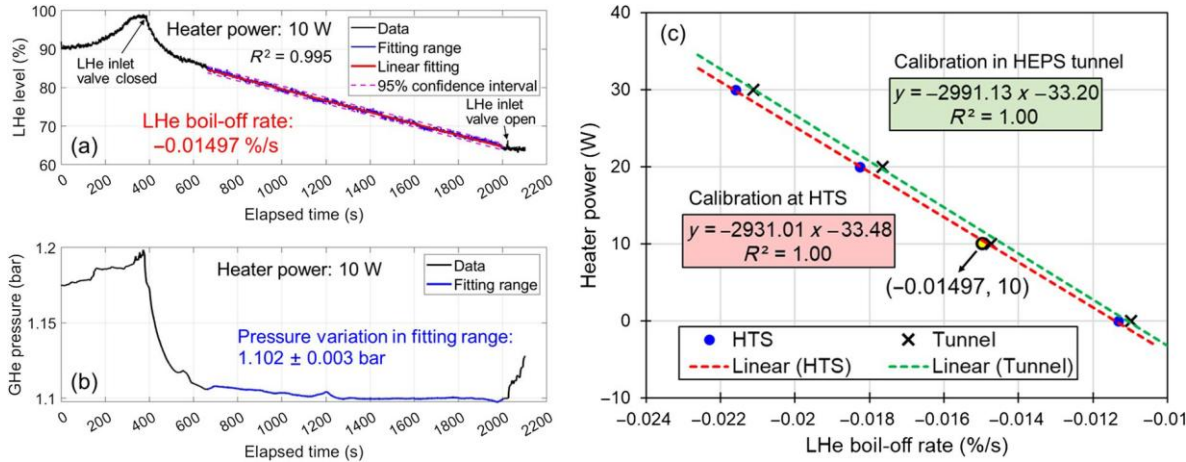

- **RF voltage:** > 25%
- **Q<sub>0</sub> @ 1.2 MV** > 1×10<sup>9</sup>: a factor of 3~4
- **FE radiation** < 10 μSv/h for four modules: no FE, mild FE for one module

These results are equivalent to the levels observed during vertical tests of the bare cavities, **demonstrating the success of the cryomodule assembly process.**

# Heat load contribution

- **Large heat load on LBP**

- **Strict space limitation** of cavity string, shorter Nb beampipe length to ensure sufficient transition from 4.2 K to 300 K
- **Trade-off** between loss factor & heat load

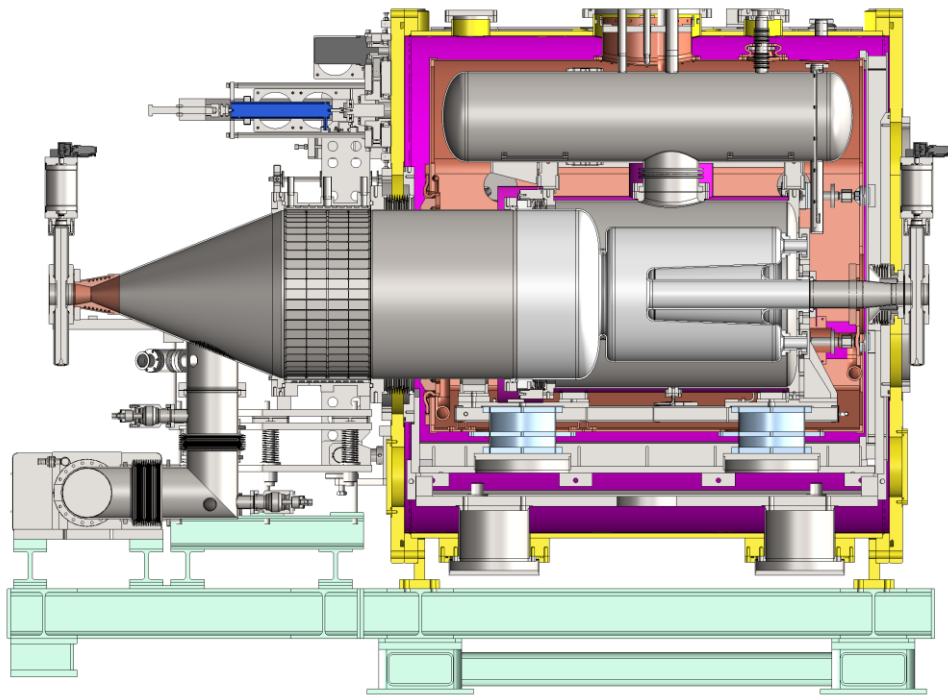

## Dynamic heat load

Breakdown	Dynamic HL (W)	%
Cavity (VT)	2.3~3.7	46%~58%
FPC (simu)	1.3	26%~20%
Large beam pipe (simu)	1.25	25%~20%
Ambient B field (calc.)	0.16	3%
<b>Total</b>	<b>5~6.4 W</b>	

## Static heat load

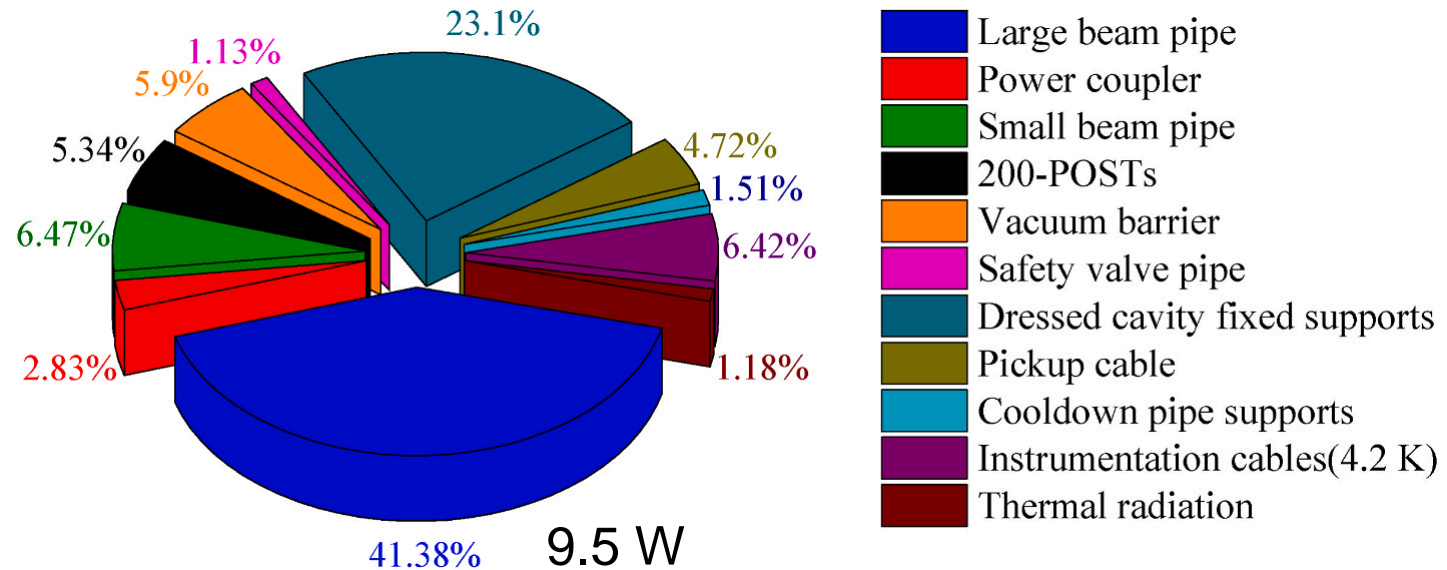

[1] R. Han *et al.*, *NIM-A* 1070,170000 (2005).

[2] P. Zhang *et al.*, *Phys. Rev. Accel. Beams* 29, 032002 (2026).

# Modules ready for installation

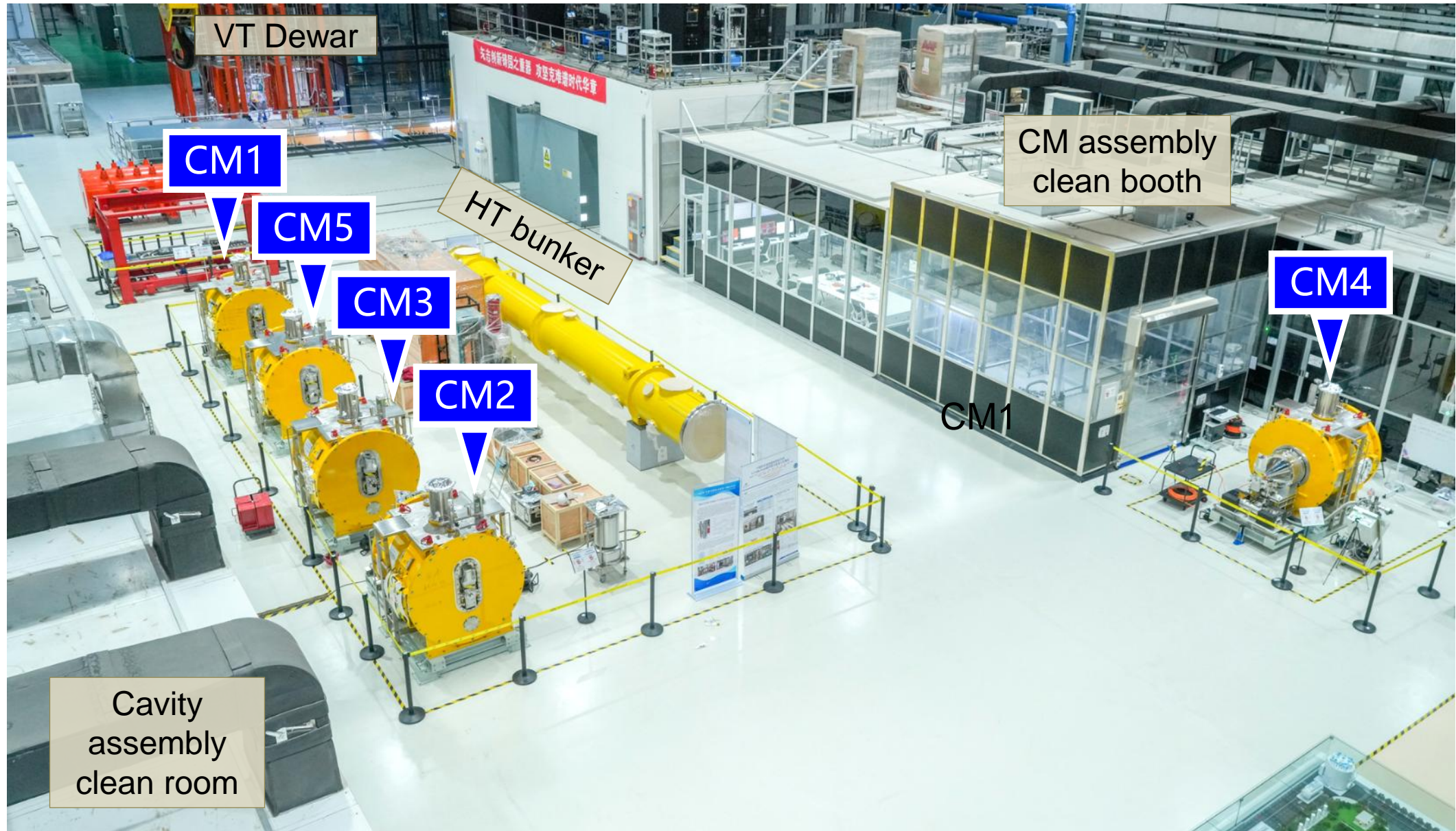

# **Installation & RF commissioning**

# Staged RF installation & commissioning

- **Commissioning strategy (modified, pragmatic approach)**

- S1: Initial beam commissioning using 500MHz “NCCs + SCC” RF configuration (vacuum scrubbing)
- S2: Install remaining SRF cavities as soon as they are ready w/ lower accum. beam dose (~41 A·h)

- **Purpose**

- Vacuum scrubbing of the SR: Large outgassing from sync. light irradiation on vacuum chambers
- Minimize contamination risk: Avoid exposing SRF cavities to vacuum incidents and gas absorption
- Allow more development time: Reserve additional time for the new 166MHz SRF cavities

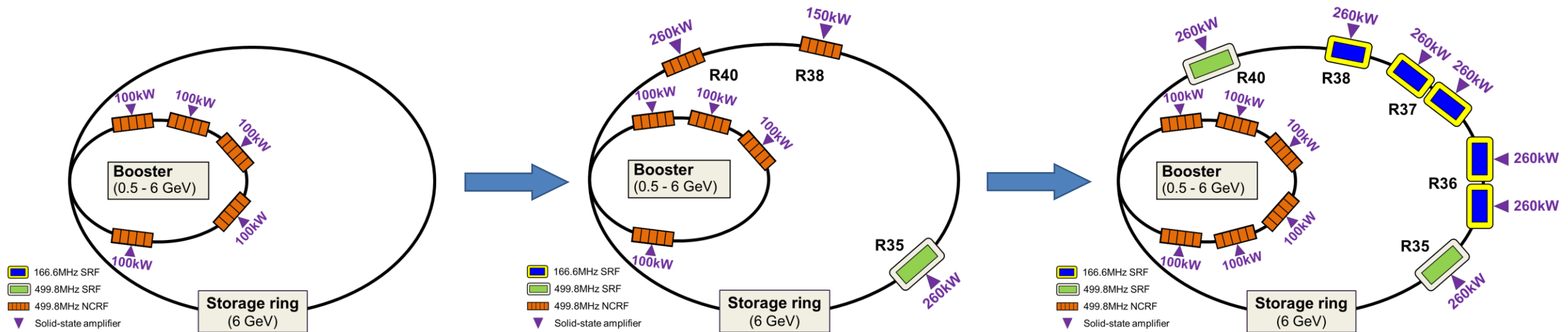

**Booster CX (2023.08~2023.11)**

**S1: SR CX (2024.07~2025.05)  
Vacuum scrubbing**

**S2: SR CX (2025.08~)  
Nominal operation**

# SR commissioning: stage 1 (07.2024~05.2025)

- Total RF voltage: 3.85MV
- Total beam power: 159kW, **max. beam current: 60mA**
- Stable op. for NCC (<90kW), limit for SCC (<180kW, <1.75MV)

2×500MHz NCCs + 1×500MHz SCC

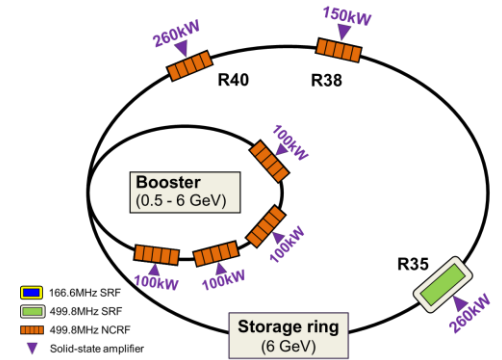

High reflection

## Vacuum threshold (Stage 1)

- 500SCC\_cav < 1e-6 Pa, 500SCC\_FPC < 1e-6 Pa
- 500NCC\_cav < 3e-5 Pa

SR cavity parameter	500NCC	500SCC
No. of cavities	2	1
Rf frequency (MHz)	499.8	499.8
Vc per cavity (MV)	1.1	1.65
Cavity wall loss	41 kW	~0 kW
Coupling	$\beta=2$	$Q_e=8e4$
Beam current	<b>60 mA</b>	
U0 (w/o IDs)	<b>2.64 MeV</b>	
Forward power per cavity	<b>88 kW</b>	143 kW
Reflected power per cavity	3 kW	<b>75 kW</b>
Beam power per cavity	44 kW	68 kW

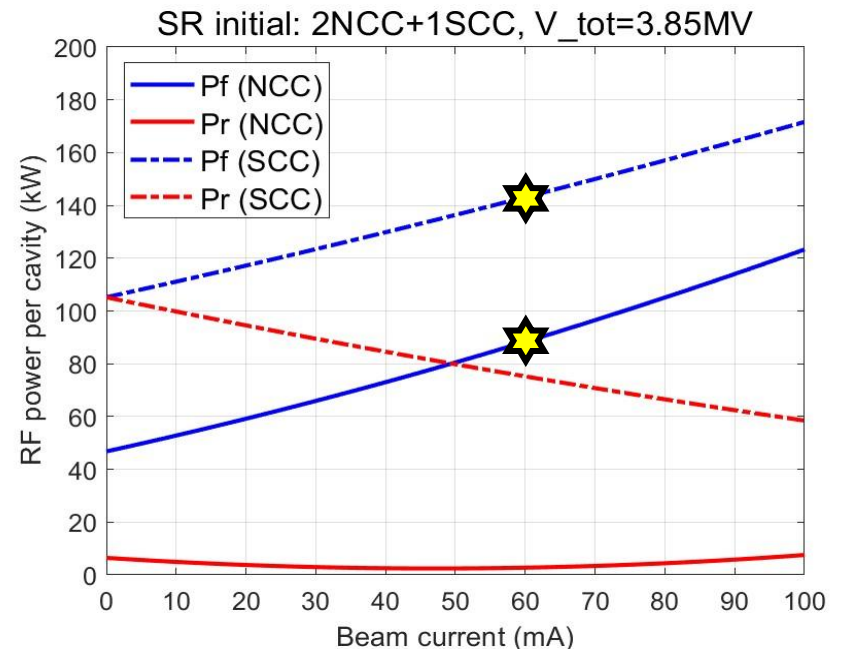

# SR commissioning: stage 2 (since 08.2025)

## Equipment relocation & install.

- Relocate: 2×NC cavities (SR→BS)
- Relocate: 1×150kW SSA (SR→BS)
- Installed: 5×166MHz SRF cavities in SR to support 200mA current

Parameter	CX stage 1	CX stage 2	Nominal op.
Time period	2024.07~2025.05	2025.08~present	2026 onward
Booster	4×500NCCs	6×500NCCs	6×500NCCs
SR	2×500NCCs 1×500SCC	5×166SCCs 1×500SCC	5×166SCCs 1×500SCC
Max. Ib (U0)	<b>60mA</b> (2.64MeV)	<b>100mA</b> (4.14MeV)	<b>200mA</b> (4.14MeV)
RF voltage	500SCC: 1.65MV 500NCC: 1.10MV Total: 3.85MV	166SCC: 1.2MV 166SCC_ttl: 6MV	166SCC: 1.2MV 166SCC_ttl: 6MV
RF power	500SCC: 143kW 500NCC: 88kW Total: 319kW	166SCC: 112kW 166SCC_ttl: 562kW HC_Pb: -52kW	166SCC: 193kW 166SCC_ttl: 964kW HC_Pb: -104kW

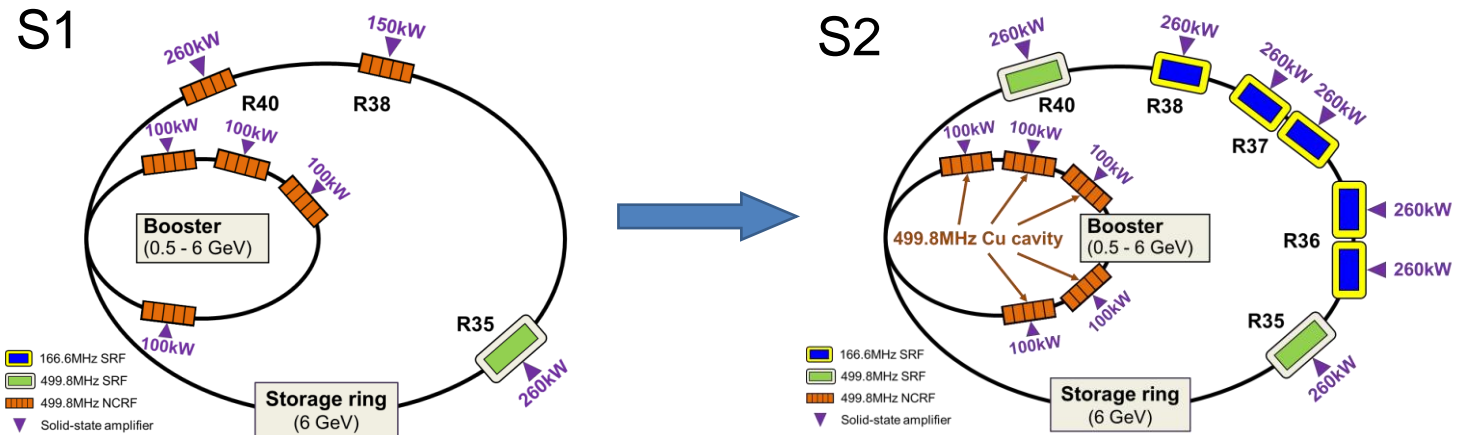
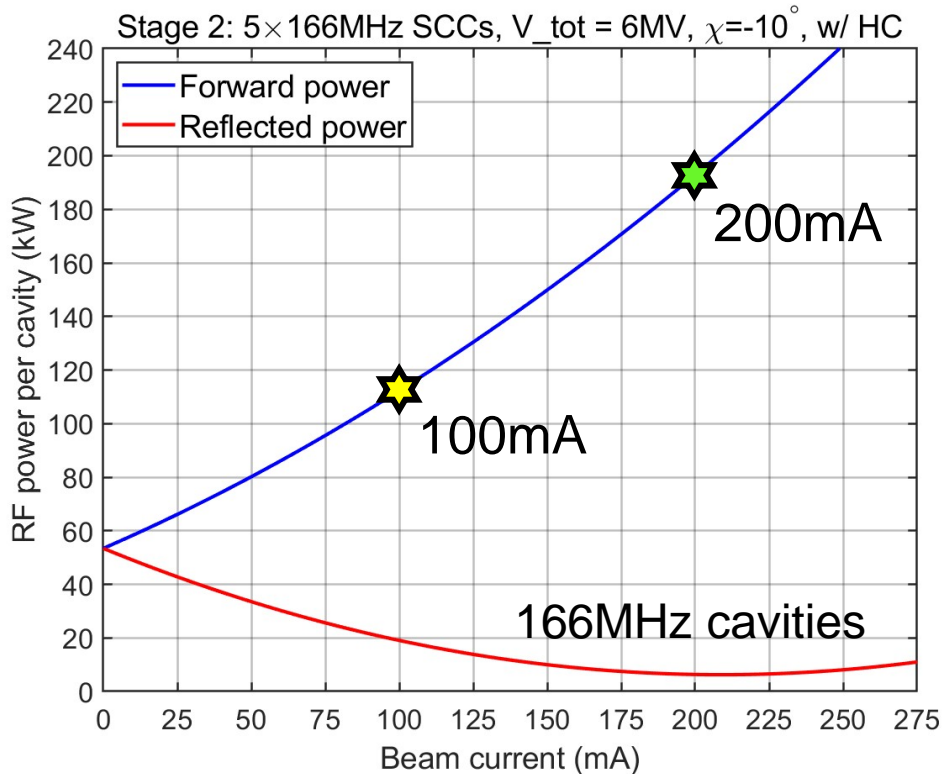

# Milestones of RF inst. & CX

---

## Booster ring

- Oct. 2023, Booster RF system commissioned
- **Nov. 2023, Booster ring commissioned**

## Storage ring

### □ Stage 1 commissioning

- Jul. 2024, Storage-ring RF system (stage 1) commissioned
- **Aug. 2024, HEPS achieved 25mA current in storage ring**

### □ Stage 2 commissioning

- **Aug. 2025, Storage-ring SRF system commissioned**
- **Sep. 2025, 166MHz+500MHz SRF cavities accelerated 100mA beam**
- **Oct. 2025, HEPS commissioned and passed acceptance tests**
- Since Dec. 2025, HEPS in pilot user runs & machine studies

# Transportation

- Following successful qualification testing at HTS, all cryomodules were transported to the HEPS tunnel and installed in their designated straight sections (distance ~ 1.5 km)
- **Challenges:** The cryomodules are heavy (~8 tons) and contain many thin-wall structures (~1.5 mm). They must remain stable during transport and installation to avoid excessive stress that could cause contamination or vacuum leaks
- **Result:** The maximum recorded shock on each of the five modules (excluding supports) was below 0.5 g in all directions, meeting transportation requirements. Vacuum integrity of all modules remained well maintained before and after transportation.

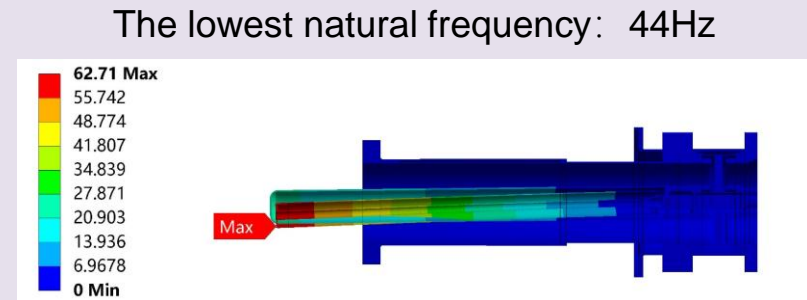
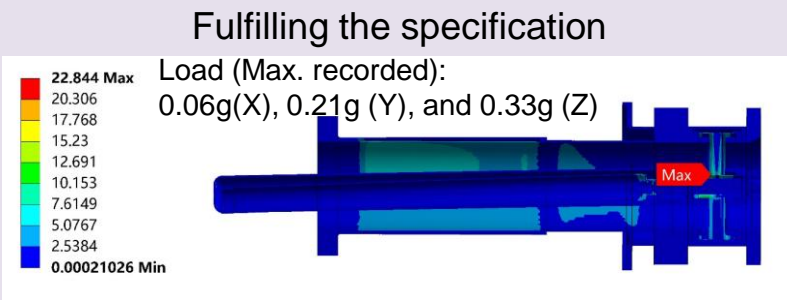
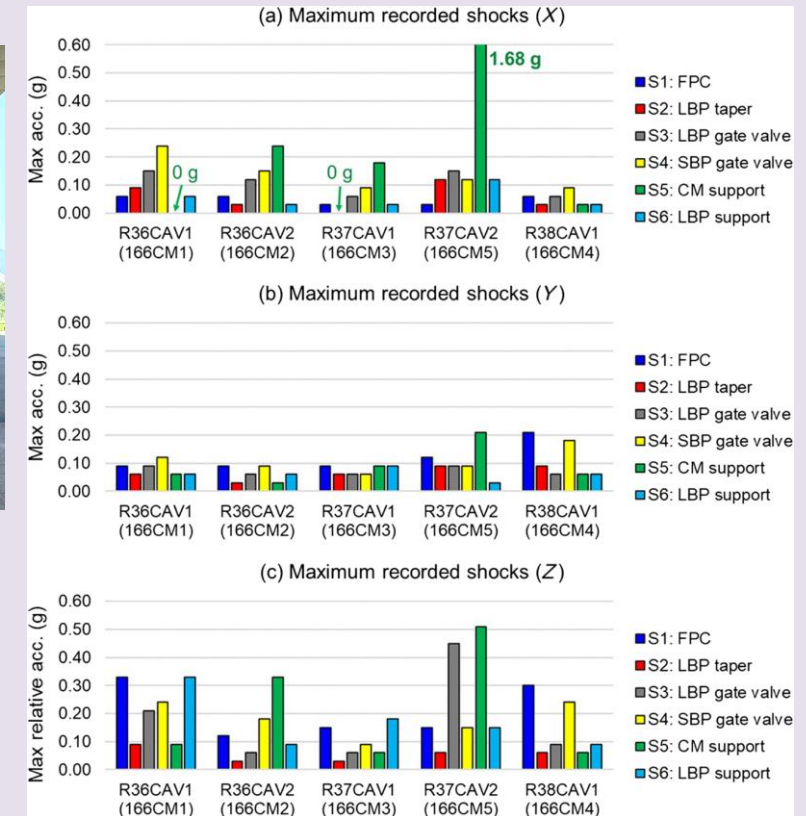
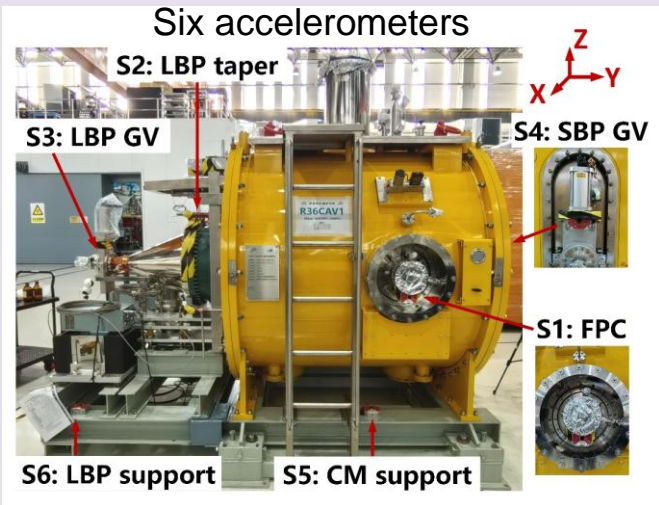

# Vacuum connections in the tunnel

- **Cleanroom practices implemented** during beamline connections with adjacent sectors to minimize contamination to SRF cavities, RF WP responsible with Vacuum WP participated in
- **First cavity valve opening (300K)** on Jul 15, 2025: All cavities at 300K, closed after a few mins
  - Before:  $10^{-7}$  Pa (cavity),  $10^{-7}$  Pa (vac. chamber); Upon opening: worst vacuum  $1.6 \times 10^{-5}$  Pa; Recovery: ~2hrs
- **Second cavity valve opening (4K)** before beam CX on Aug 11, 2025
  - Before:  $10^{-8}$  Pa (cavity),  $10^{-9}$  Pa (vac. chamber); Upon opening: worst vacuum  $5 \times 10^{-7}$  Pa; Recovery: a few mins



Purge w/ dust-free nitrogen



Vacuum connection

# 166MHz SRF modules in the tunnel



# 500MHz SRF module in the tunnel

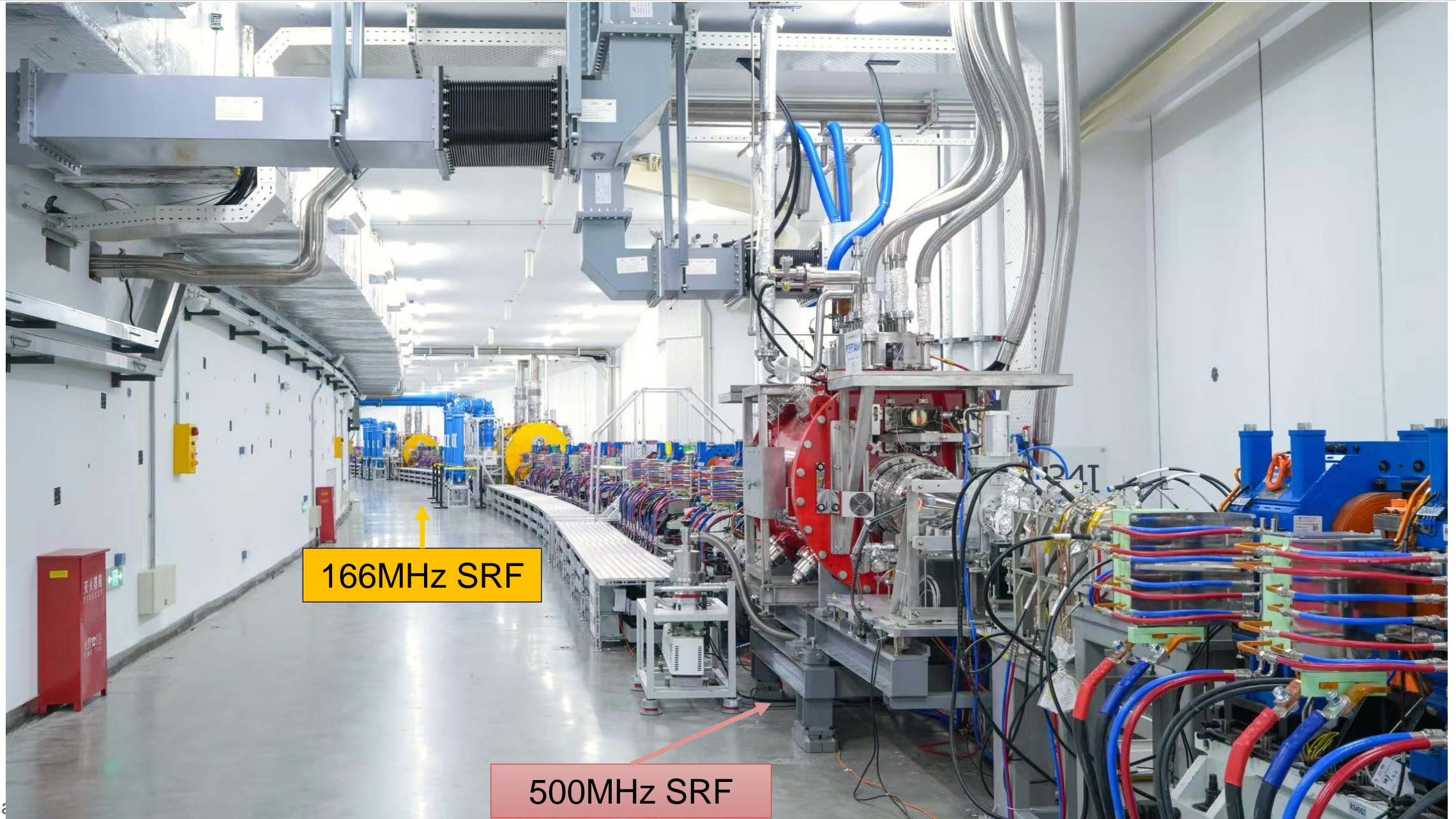

# Frist cooldown in the tunnel (11 days, 7CMs)

- All 7 CMs cooled down simultaneously (166MHz & 500MHz)
- **Cooldown requirements: max.  $\Delta T < 10K$ , cooling rate  $< 5K/h$**
- Uniform cooling to minimize thermal stress on large flanges (505mm for 166MHz, 300mm for 500MHz)

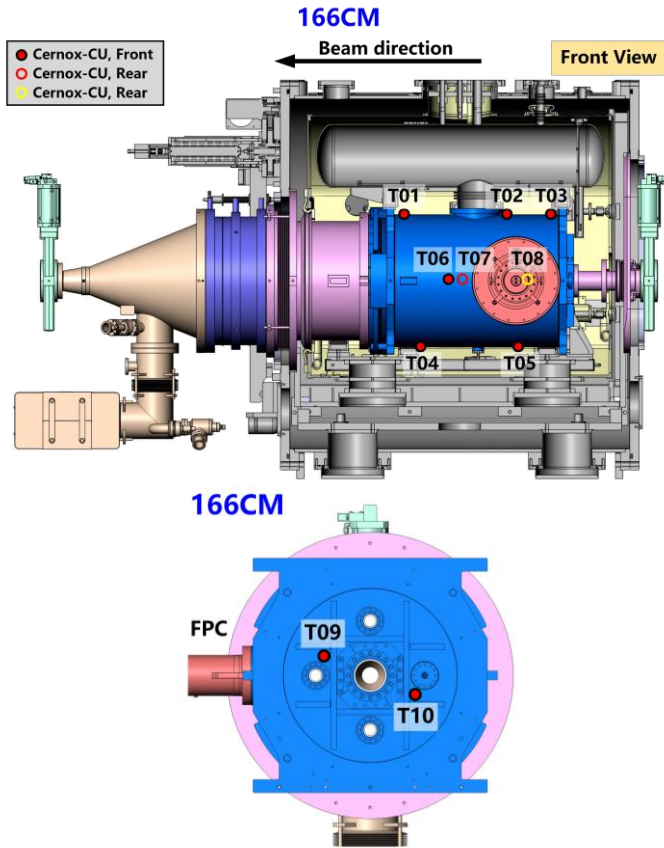

Use T01-T10 to calculate  $\Delta T$

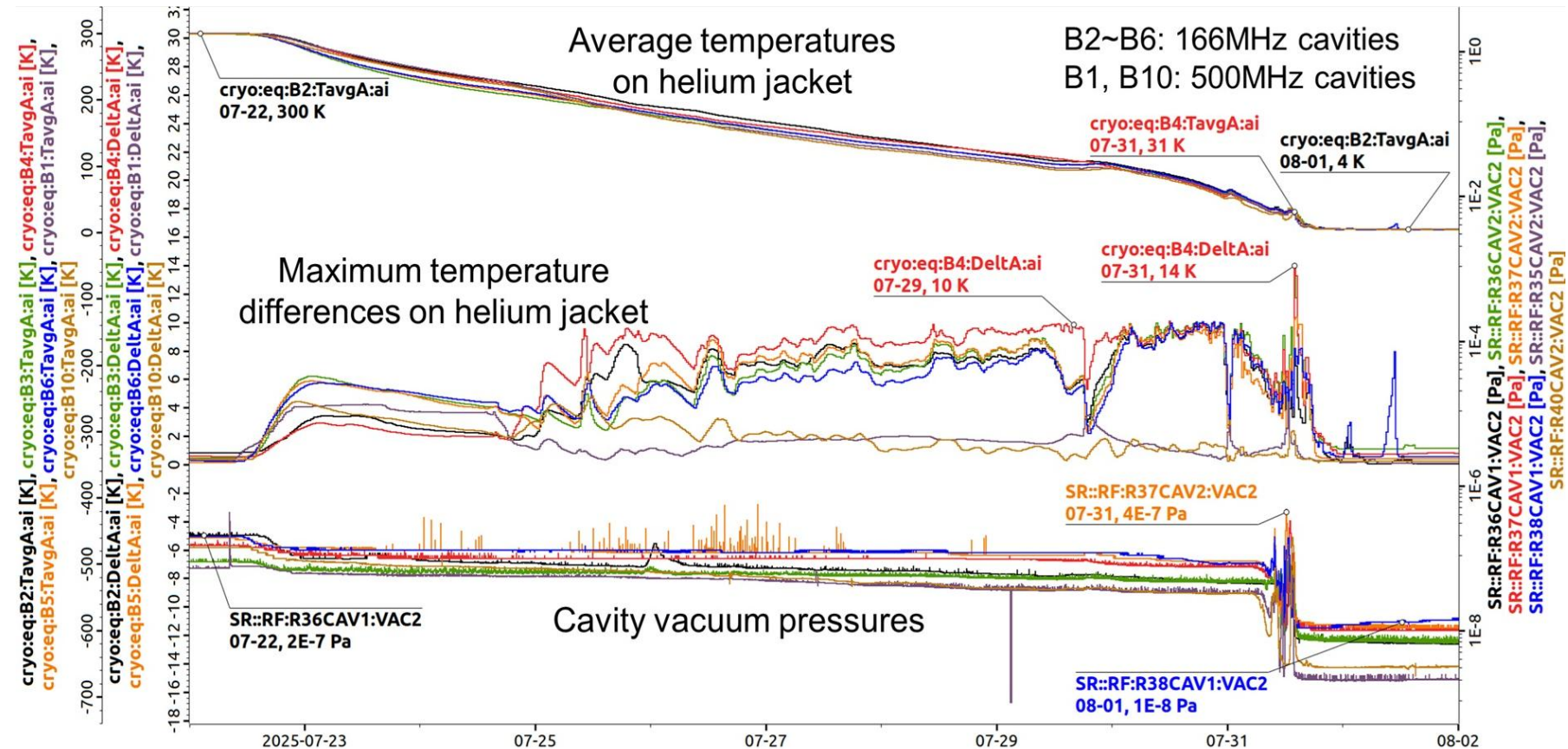

# Conditioning at 4K

Vacuum threshold during 4K conditioning:  $3 \times 10^{-5}$  Pa

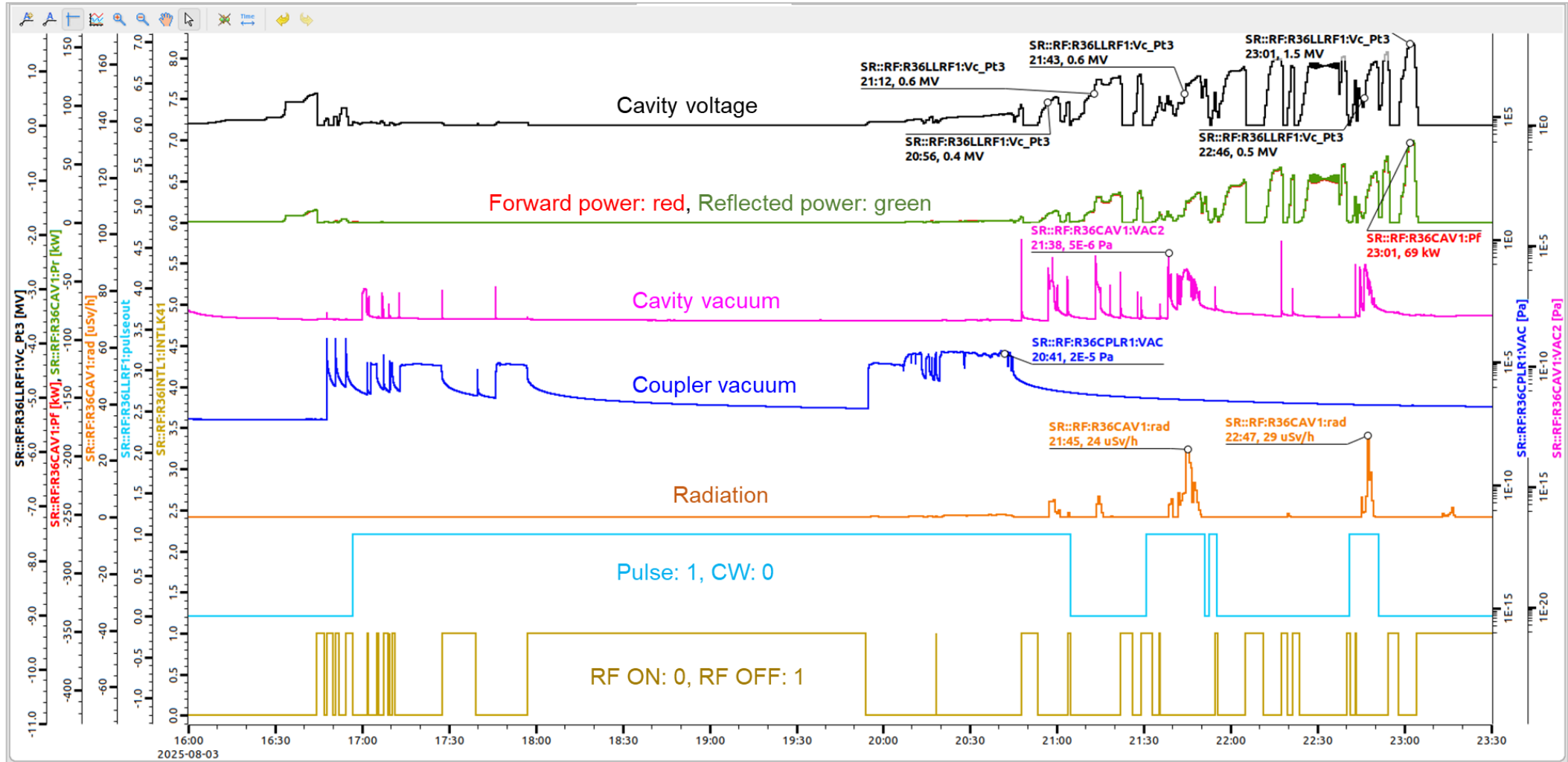

# SRF cavities after RF conditioning

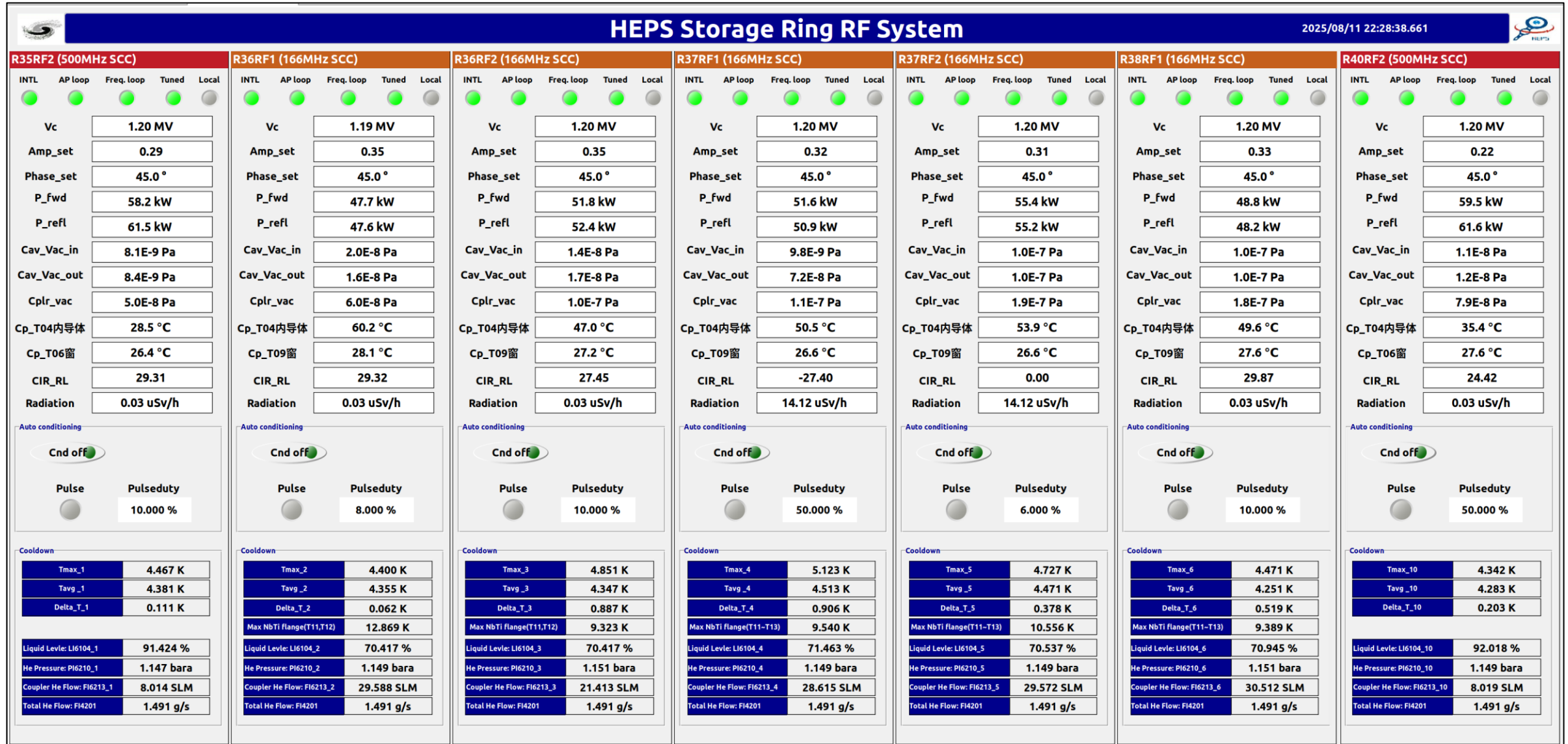

# **Beam commissioning & operation**

# Beam commissioning

- Aug. 12, 2025, SR beam commissioning began
- Aug. 18, 2025, first bunch lengthening achieved (166MHz + 500MHz)
- Sep. 12, 2025, beam current reached 100mA, beam power 310kW (HHC ON)
- Jan. 8, 2026, beam current reached 120mA, beam power 380kW (HHC ON)
- Mar. 7, 2026, beam current reached 150mA, beam power 468kW (HHC ON)

Admin. vacuum threshold  
 $1 \times 10^{-6}$  Pa for SRF cavities

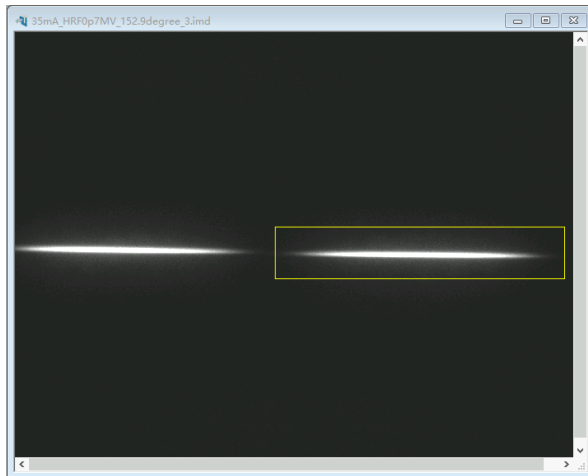

Bunch lengthening

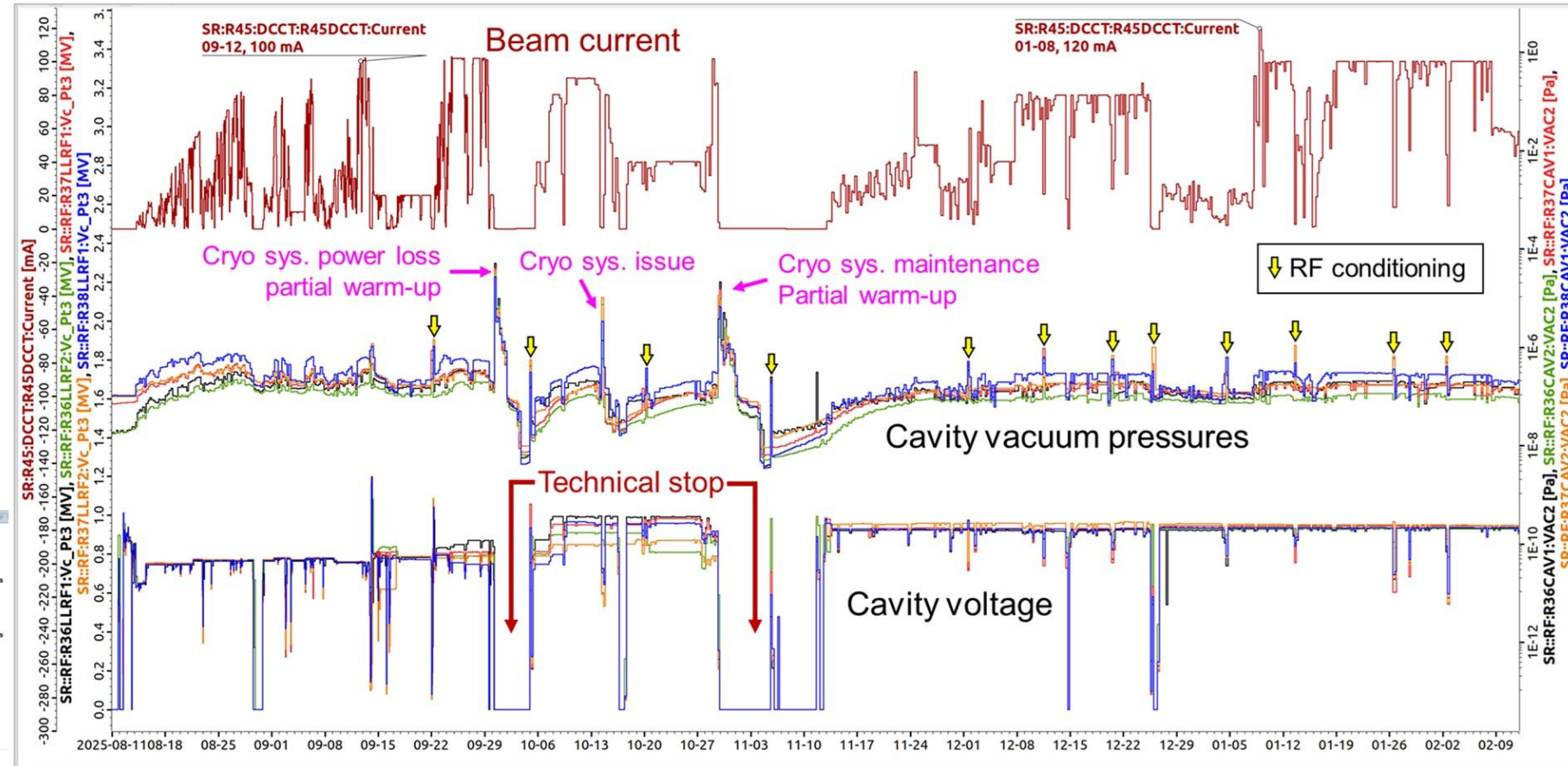
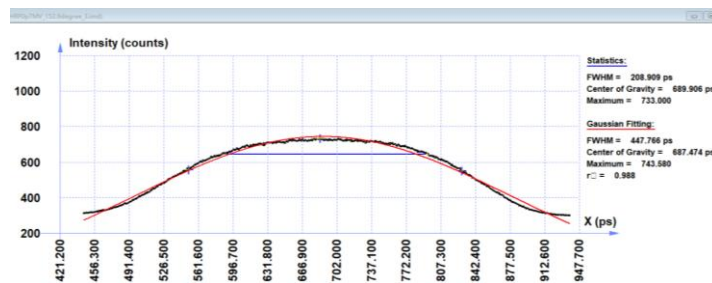

# Bunch lengthening

- Nearly ideally flat bunch distribution at arbitrary beam current
  - e.g.  $\sim 1.2$  nC / bunch, 28 mA @ 108 bunches,  $\sim 3.2$  times bunch lengthening

Courtesy Haisheng Xu (IHEP).

### HC phase control

Enable SW	Loop SW
1. <input type="checkbox"/>	2. <input checked="" type="checkbox"/> Closed
R35 target $\Phi$ s	R40 target $\Phi$ s
110.00 deg	104.47 deg
R35 $\Phi$ s readback	R40 $\Phi$ s readback
91.82 deg	104.15 deg

## HC control loop

$\cos(\Phi_s) = P_b / (I_b \cdot V_c)$   
Control target:  $\delta\Phi_s < 1^\circ$   
RF  $\Phi$  tuning step:  $0.05^\circ$   
Enable when  $I_b > 30$  mA

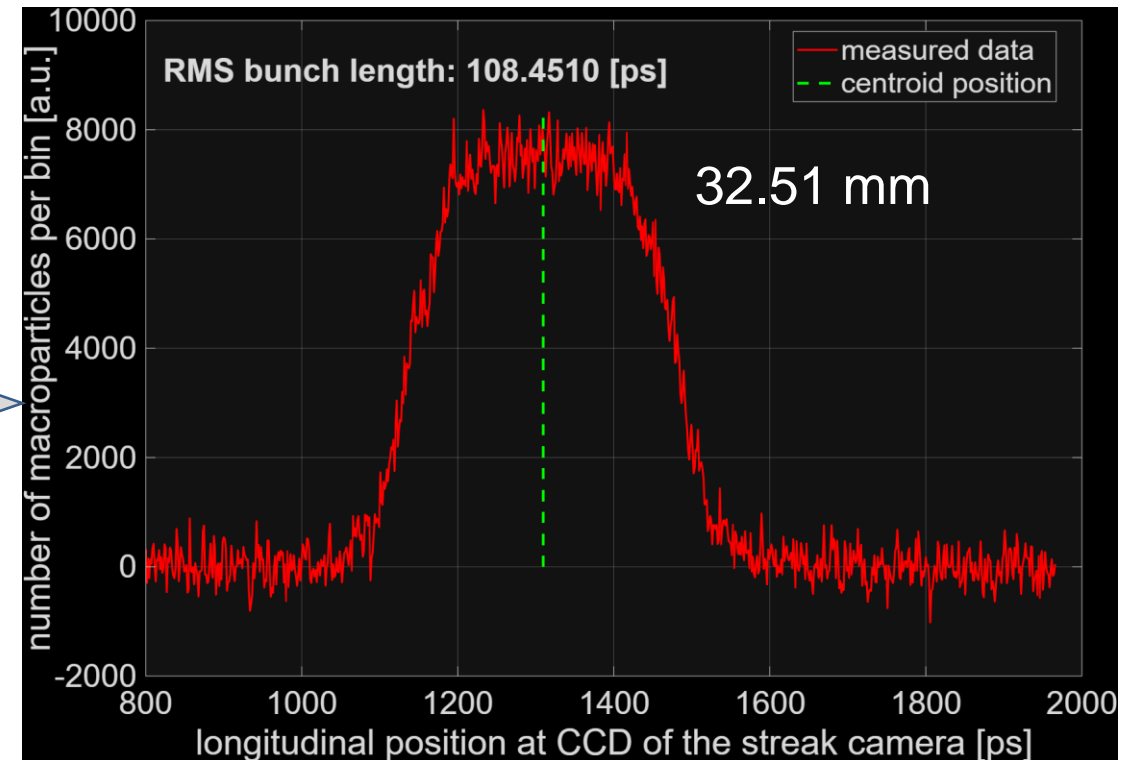
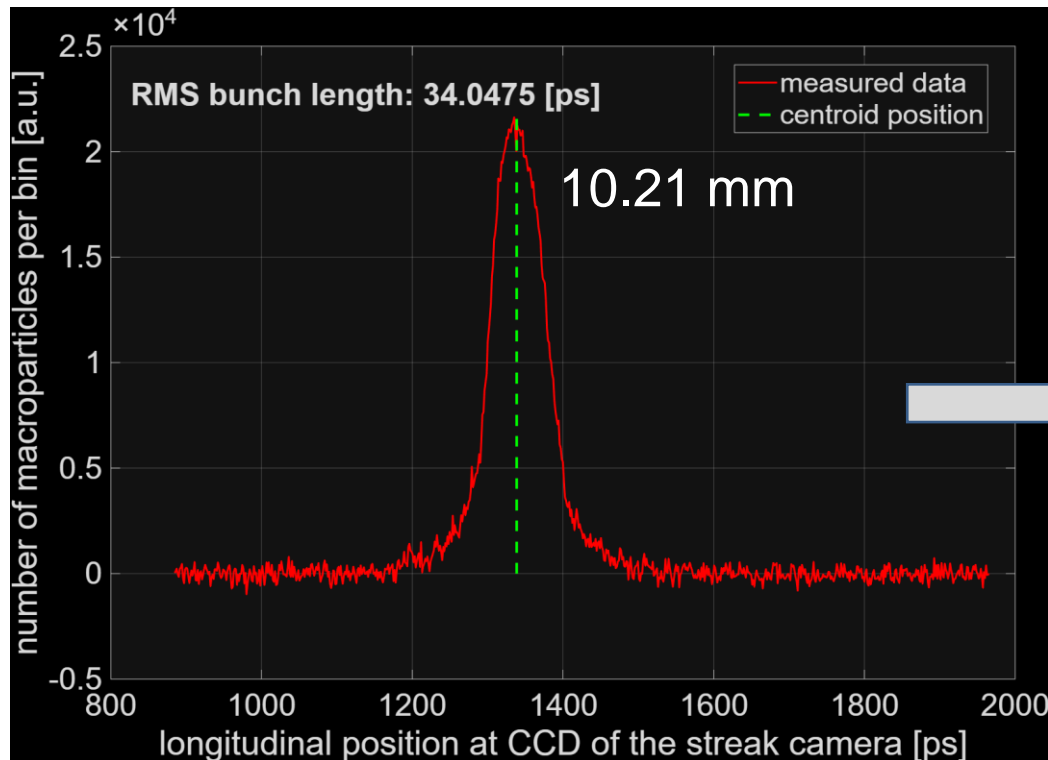

# RF operation parameters at 100mA

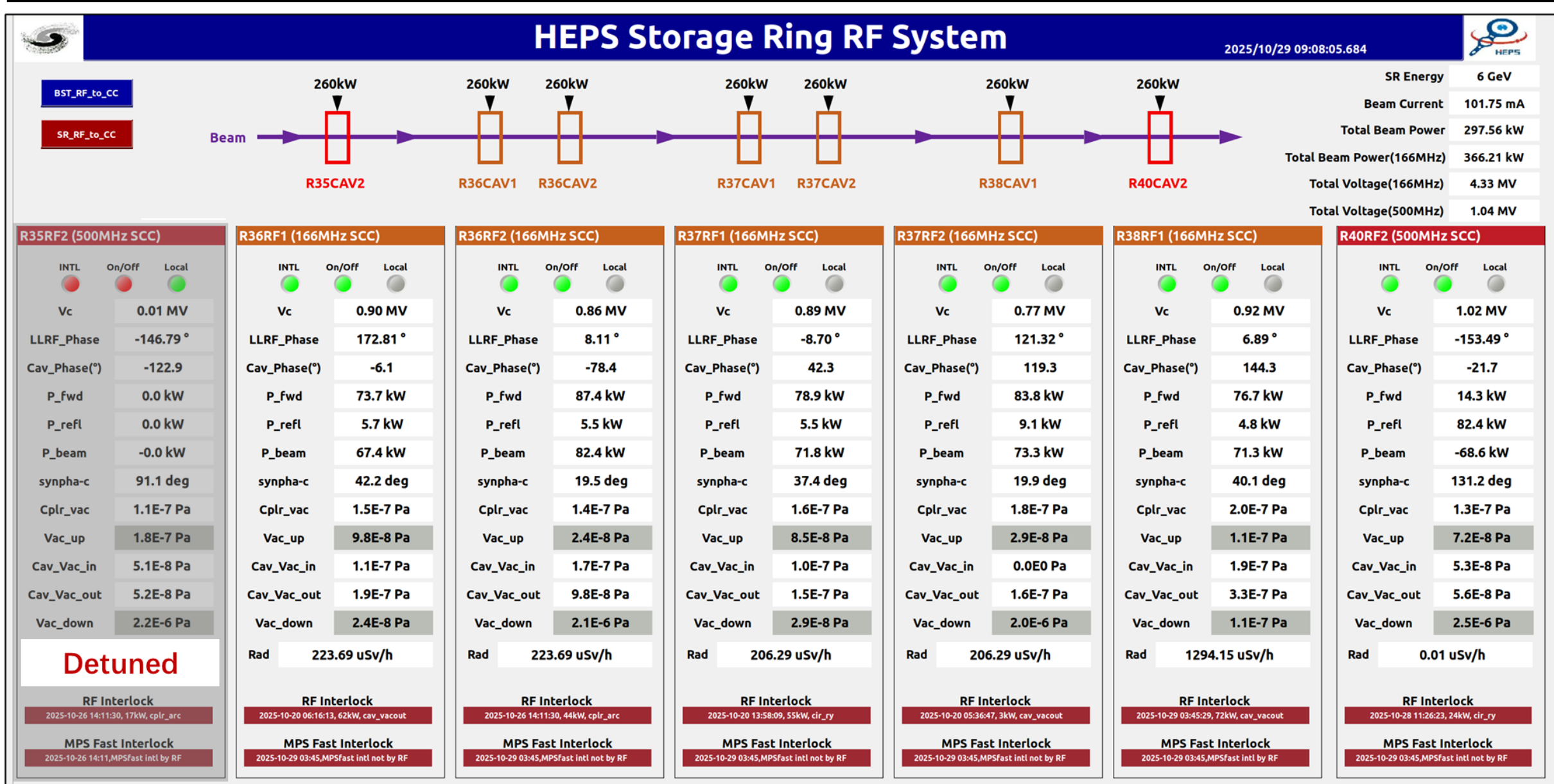

# RF operation parameters at 150mA

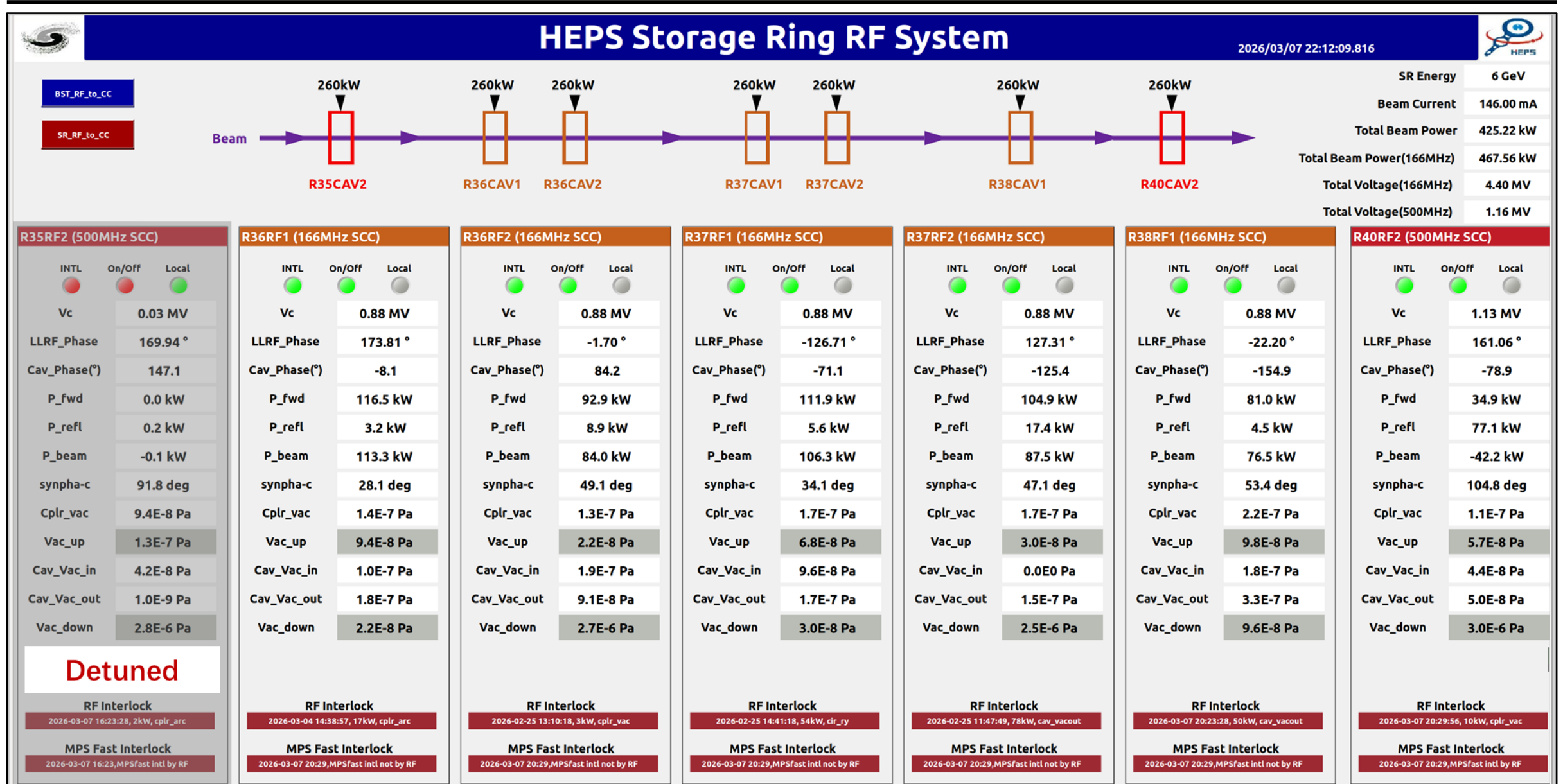

# RF control performance at 100mA

- Excellent stability performance achieved and attributed to: high-performance LLRF systems, low phase-noise SSAs, well-designed cavities, and proper grounding

(a) Amplitude stability (166MHz SCC, R36CAV2)(100mA)

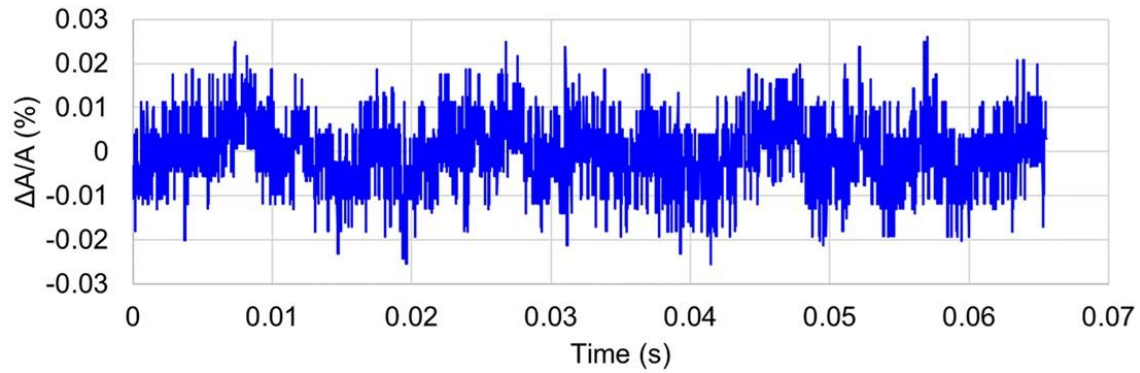

**$\pm 0.03\%$  (amp),  $\pm 0.02^\circ$  (phase)**

(b) Phase stability (166MHz SCC, R36CAV2)(100mA)

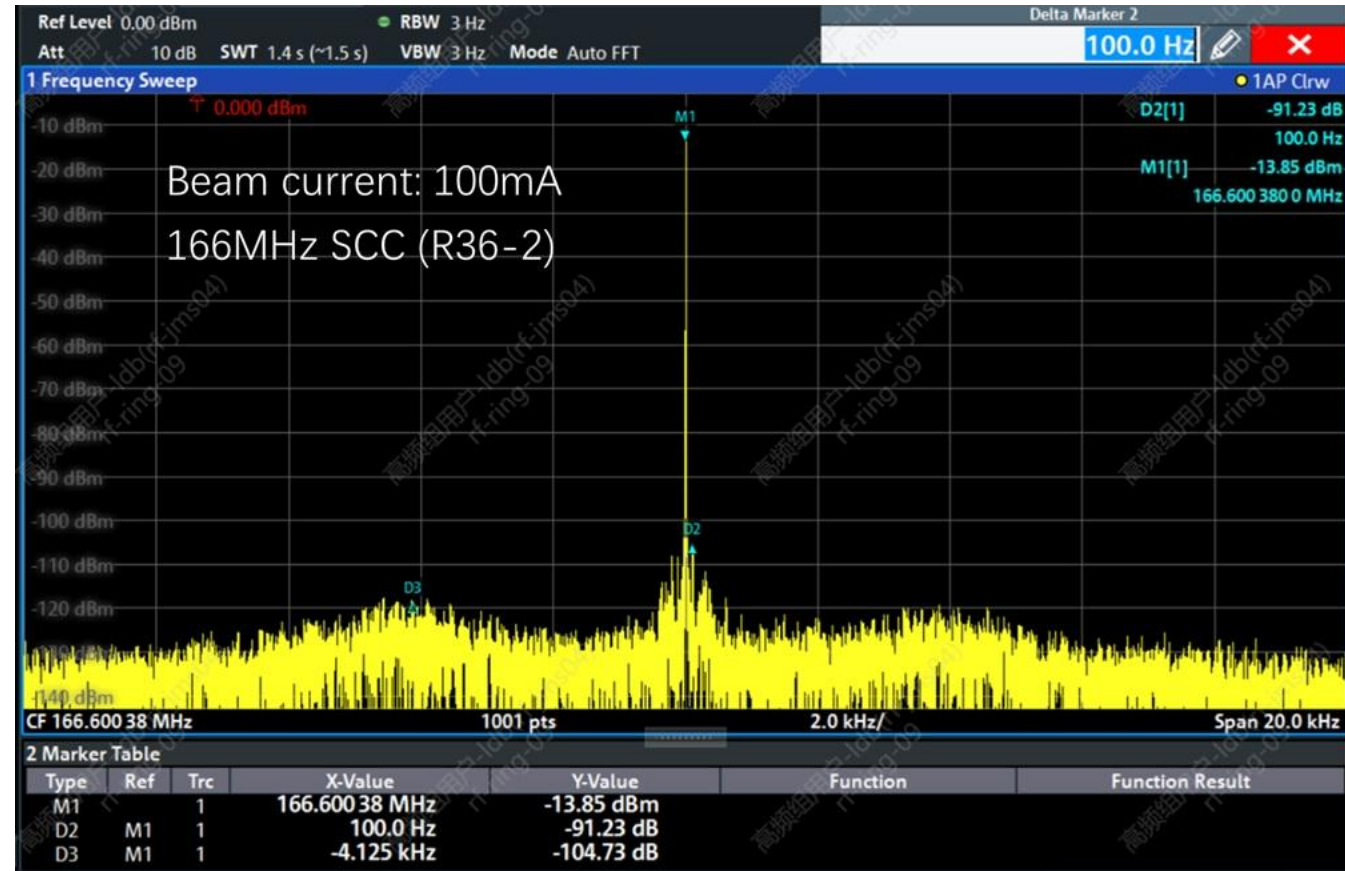
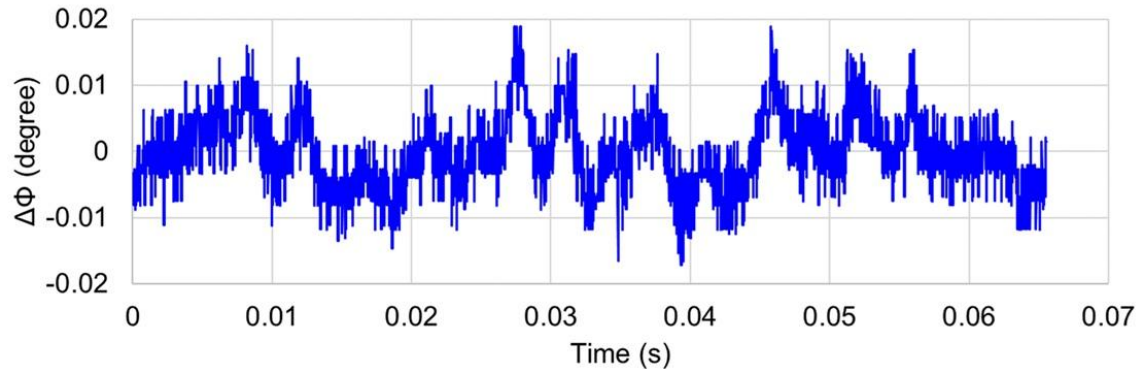

# Cavity performance check: no degradation

166MHz	HTS (2023, 2025)				HEPS tunnel (2025.08)				HEPS tunnel (2025.11)		HEPS tunnel (2026.04)		
Cav #	SL (W)	DL (W)	Q0	Rad ( $\mu\text{Sv/h}$ )	DL (W)	Q0	HL_tot (W)	Rad ( $\mu\text{Sv/h}$ )	DL (W)	Q0	DL (W)	Q0	Rad ( $\mu\text{Sv/h}$ )
R36CAV1	35.9	6.7	$1.6 \times 10^9$	0.10	5.3	$2.0 \times 10^9$	45.1	0.03	/	/	/	/	/
R36CAV2	32.7	7.0	$1.5 \times 10^9$	0.10	7.3	$1.4 \times 10^9$	47.2	0.03	/	/	/	/	/
R37CAV1	35.3	6.3	$1.6 \times 10^9$	84	5.8	$1.8 \times 10^9$	44.5	12.50	/	/	7.2	$1.5 \times 10^9$	74
R37CAV2	33.4	5.1	$2.1 \times 10^9$	0.11	5.5	$1.9 \times 10^9$	38.3	12.59	/	/	/	/	/
R38CAV1	32.7	5.6	$1.9 \times 10^9$	0.09	6.2	$1.7 \times 10^9$	38.9	0.03	5.2	$2.0 \times 10^9$	/	/	/

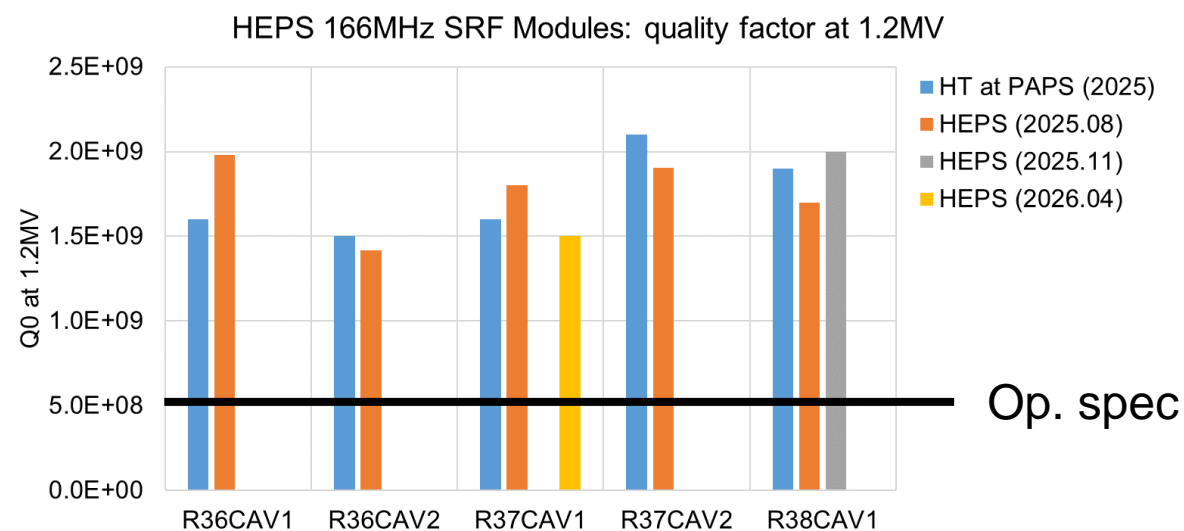
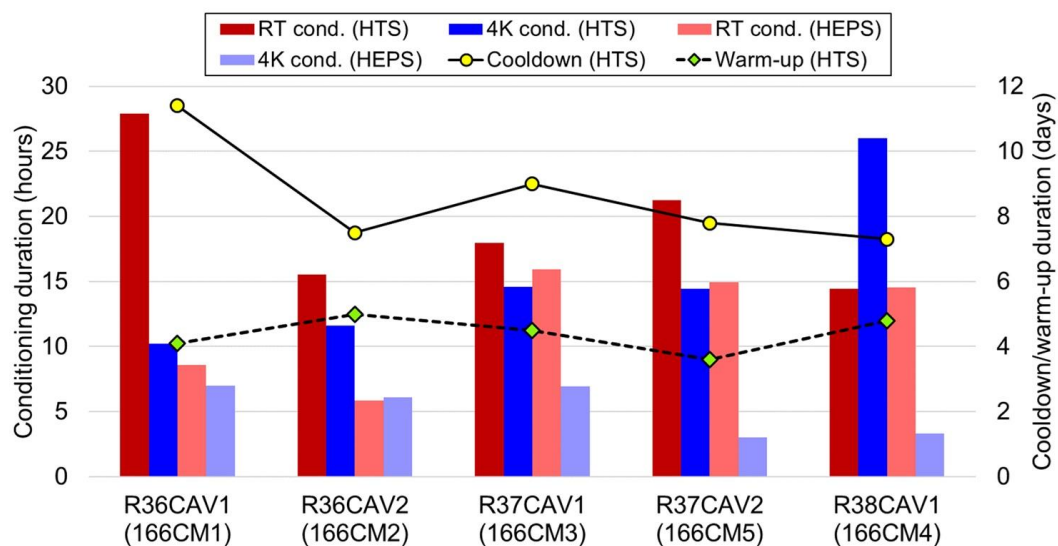

# Beam trips during S2 CX & 3 pilot user runs

2025.08.11~2026.05.01

Total beam trips (RF recorded): 245

2025.08.11~2026.05.01 Beam trips by Genre

■ Vacuum ■ Arc ■ Loop ■ Temp ■ RL ■ Coolant ■ Cryo ■ Non-RF MPS ■ Max Power ■ Other

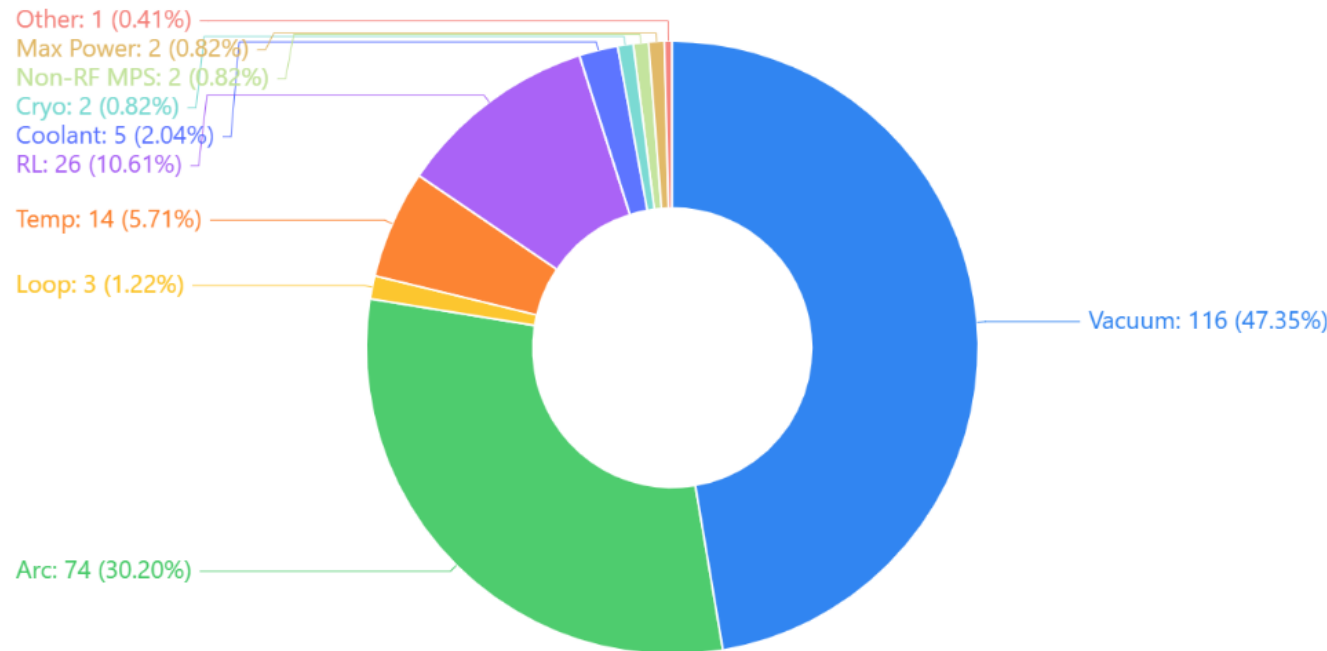

RF interlock system recorded interlock events causing beam trips (2025.08.11~2026.05.01)

Genre	Total beam trips
Vacuum	<b>116 (48%)</b>
Arc	<b>74 (30%)</b>
Circulator RL	26 (11%)
Temperature	14 (6%)
Coolant	5 (2%)
Cryogenics	2 (1%)
Others	8 (3%)
<b>Total</b>	<b>245</b>

# Beam trips during S2 CX & 3 pilot user runs

2025.08.11~2026.05.01

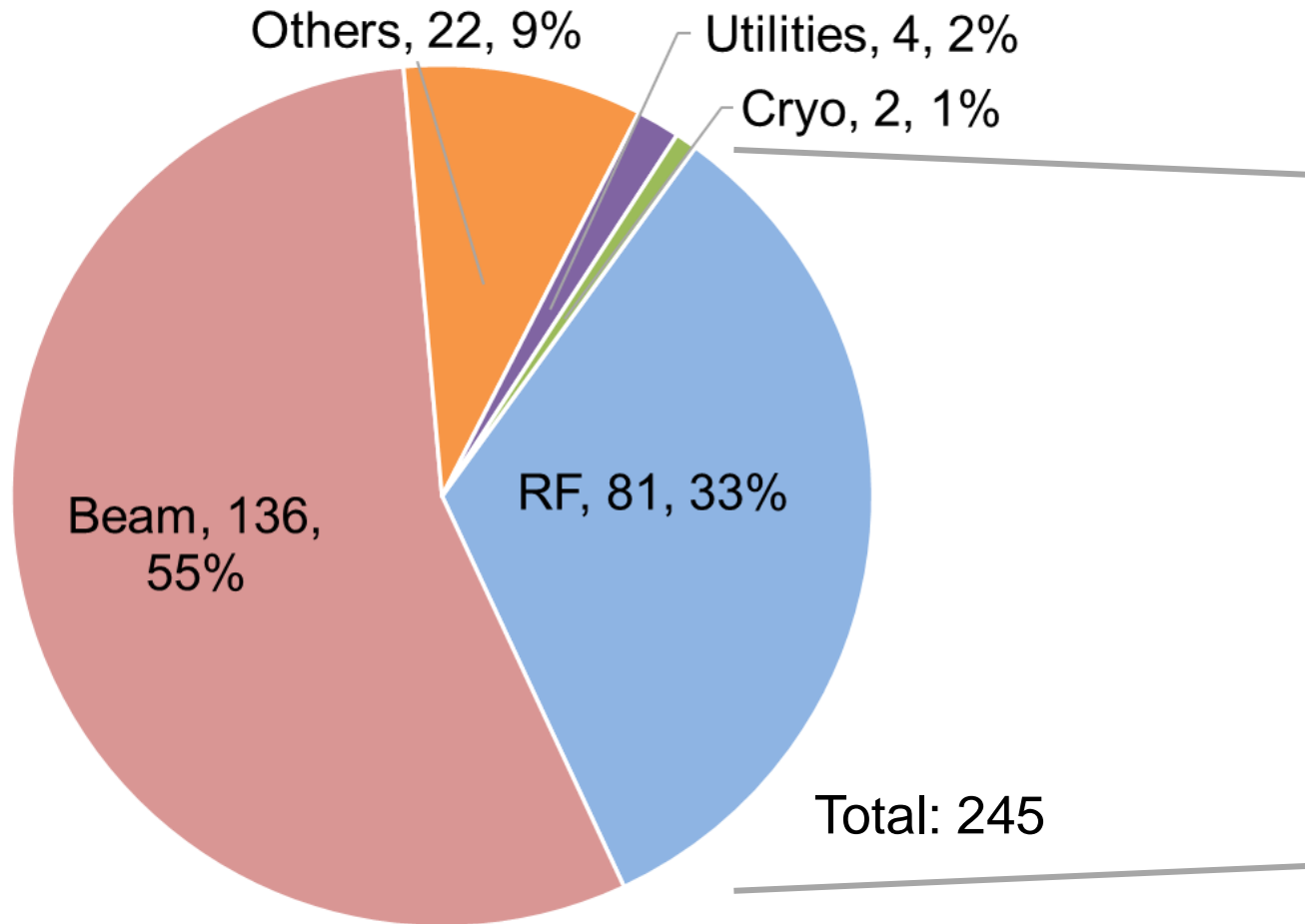

Beam trips (RF-recorded)

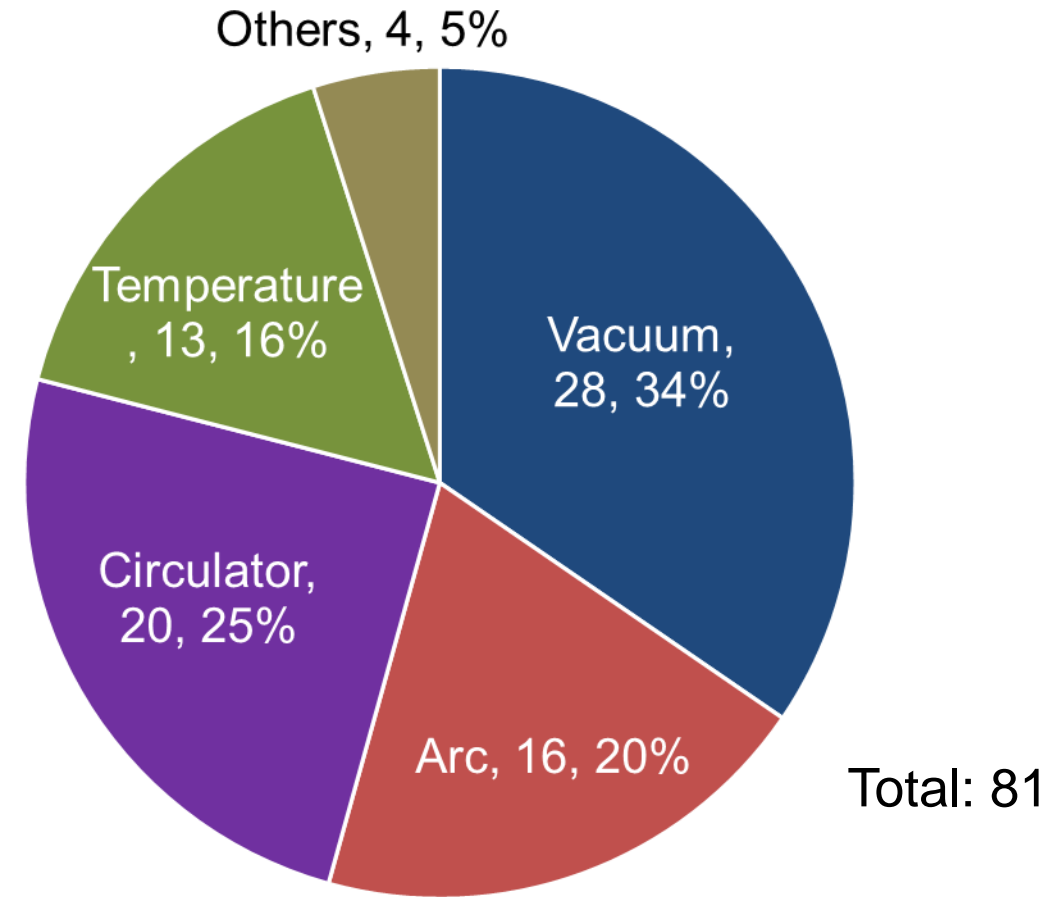

Beam trips (RF caused)

Note: Beam-related trips include all non-RF and non-RF-interfaced subsystems, such as beam orbit, fast orbit feedback (FOFB), magnet power supplies, kickers, vacuum systems, beamlines, etc.

# RF-caused beam trips in pilot user runs

Pilot User Run 1  
(2025.12.03~2025.12.25)  
(22 days)

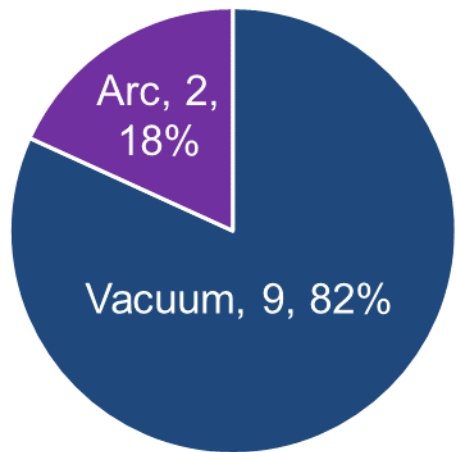

Total: 11 (6.5%)

Pilot User Run 2  
(2026.01.18~2026.02.11)  
(24 days)

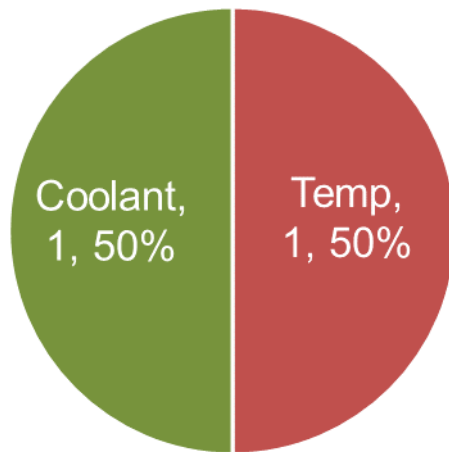

Total: 2 (6.0%)

Pilot User Run 3  
(2026.04.04~2026.05.01)  
(27 days)

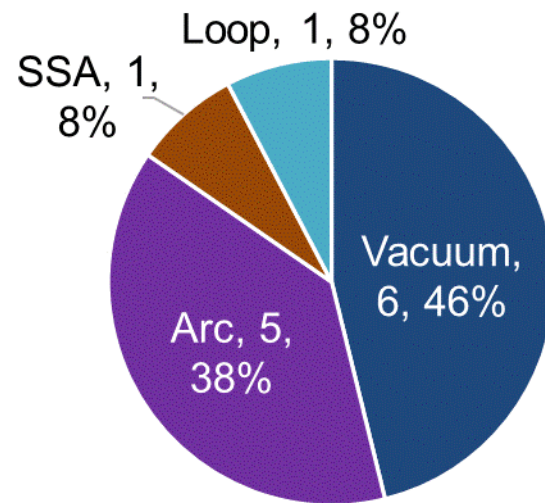

Total: 13 (TBA)

- **Signal interference:** occasional (2 times in Run2, 1 time in Run3)
- **Beam-loss-induced arc events:** significantly reduced after implementing logic-based arc discrimination, though still occasional occurrence
- **Cavity vacuum trips:** occasional, some linked to beam loss

# Open issues

#	Name	Impact	Planned actions
1	Beam-loss induced arc events	Trigger MPS	<ul style="list-style-type: none"><li>• Logic-based arc discrimination (impl.)</li><li>• Plastic optical fiber to be installed</li></ul>
2	SSA temp. & interlock signal interference (EMI)	Trigger MPS	Shielded closure to be installed in summer shutdown in 2026
3	Higher FPC temperature for two booster NC cavities	Risk of failure	<ul style="list-style-type: none"><li>• Coupling elements in procurement</li><li>• Reduced cavity voltage in operation</li></ul>
4	SSA PSM high failure rate	Not yet affecting operation	Under investigation
5	One 166MHz circulator returned to vendor for improvement	Not yet affecting operation	SAT to be completed, reinstallation for operation in summer shutdown in 2026
6	Piezo broken	Not yet affecting operation	Experiments on low-voltage piezo underway

# Summary

---

- Vacuum scrubbing phase using 500MHz RF system completed
- Booster RF and Storage-ring RF systems in nominal configuration and fully operational
  - Newly developed 166MHz SRF cavities in beam operation, **demonstrated success**
  - First active SRF harmonic cavity operational in the first week, routinely elongating bunch by a factor of 3
- Key issues identified and analyzed, countermeasures developed and being implemented

Commitment of RF WP to HEPS project success fulfilled.

# References

---

- [1] P. Zhang, *et al.*, "Radio-frequency system of the high energy photon source", *RDTM* 7, 159–170 (2023).
- [2] P. Zhang, *et al.*, "Development and high-current cw operation of 166.6 MHz high-power, higher-order-modes-damped  $\beta = 1$  quarter-wave SRF modules at the High Energy Photon Source", *Phys. Rev. Accel. Beams* 29, 032002 (2026).
- [3] H. Zheng, *et al.*, "Transport of the 499.8 MHz SRF module for the BEPCII upgrade project", *Nuclear Engineering and Technology* 58, 104319 (2026).
- [4] R. Han, *et al.*, "Thermal performance analysis and cryogenic experimental measurements of the 166.6 MHz cavity cryomodule for the High Energy Photon Source", *NIM-A* 1070, 170000 (2025).
- [5] H. Zheng, *et al.*, "Development and tests of the 499.8 MHz srf cryomodules for HEPS", *JINST* 19, P10031 (2024).
- [6] L. Guo, *et al.*, "Development of a 166.6 MHz  $\beta = 1$  higher-order-mode-damped superconducting cavity", *Rev. Sci. Instrum.* 95, 074702 (2024).
- [7] T. Huang *et al.*, "Design modification and high-power tests of the 500 MHz normal-conducting 5-cell cavities for HEPS", *JINST* 19, P06031 (2024).
- [8] H. Zheng, *et al.*, "Design Evolution of the Higher Order-Mode Damping in 166.6-MHz Quarter-Wave  $\beta=1$  Superconducting Cavities for HEPS", *IEEE Trans. Appl. Supercond.* 34, 3500309 (2024)
- [9] X. Zhang, *et al.*, "Compact design of the 166.6 MHz superconducting cavity and its beamline elements for HEPS", *NIM-A* 1059, 168972 (2024).
- [10] Y. Luo, *et al.*, "Development of a 500-MHz waveguide directional coupler with high directivity for HEPS", *RDTM* 6, 323–329 (2022).
- [11] L. Guo *et al.*, "Multipacting suppression of the HOM-damped 166.6-MHz  $\beta=1$  quarter-wave superconducting cavities at HEPS", *JINST* 16, P11003 (2021).
- [12] Z. Deng, *et al.*, "Development of an automatic control and analysis system for the conditioning of high-power couplers at IHEP", *JINST* 16, P07027 (2021).
- [13] Y. Luo, *et al.*, "Design and performance tests of a modular 166.6-MHz 50-kW compact solid-state power amplifier for the HEPS-TF project", *JINST* 16, P04011 (2021).
- [14] T. Huang, *et al.*, "High-power tests and solution to overheating at cavity-coupler interface of the 166.6-MHz  $\beta=1$  superconducting quarter-wave resonator for HEPS", *AIP Advances* 11, 045024 (2021).
- [15] D. Li, *et al.*, "Active microphonics noise suppression based on DOB control in 166.6-MHz superconducting cavities for HEPS", *RDTM* 5, 153–160 (2021).
- [16] H. Zheng, *et al.*, "Design optimization of a mechanically-improved 499.8 MHz single-cell superconducting cavity for HEPS", *IEEE Trans. Appl. Supercond.* 31, 3500109 (2021).
- [17] T. Huang, *et al.*, "Development of a low-loss magnetic-coupling pickup for 166.6 MHz quarter-wave  $\beta=1$  superconducting cavities", *NUCL SCI TECH* 31, 87 (2020).
- [18] X. Zhang, *et al.*, "Design and Mechanical Performance of a Dressed 166.6 MHz  $\beta=1$  Proof-of-Principle Superconducting Cavity in Horizontal Tests", *IEEE Trans. Appl. Supercond.* 30, 3500208 (2020).
- [19] T. Huang, *et al.*, "Development of fundamental power couplers for 166.6 MHz superconducting quarter-wave  $\beta=1$  proof-of-principle cavities", *Rev. Sci. Instrum.* 91, 063301 (2020).
- [20] D. Li, *et al.*, "Development of a high-performance RF front end for HEPS 166.6 MHz low-level RF system", *RDTM* 4, 84–91 (2020).
- [21] X. Zhang, *et al.*, "The mechanical design, fabrication and tests of a 166.6 MHz quarter-wave  $\beta=1$  proof-of-principle superconducting cavity for HEPS", *NIM-A* 947, 162770 (2019).
- [22] P. Zhang, *et al.*, "Development and vertical tests of a 166.6 MHz proof-of-principle superconducting quarter-wave  $\beta = 1$  cavity", *Rev. Sci. Instrum.* 90, 084705 (2019).

# Thank you!



Huairou, Beijing, China

**Backup slides**

# Ancillaries: beamline components

- Design considerations: heat loss, warm-end temperature (>dew point), mechanical properties (stress/buckling), compact geometry

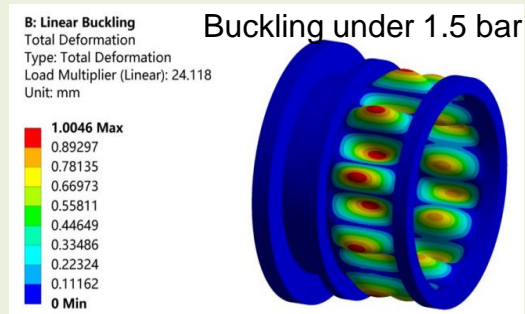
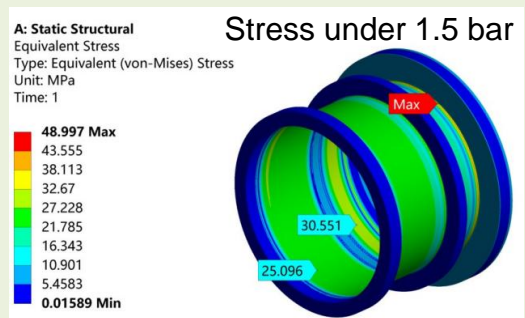
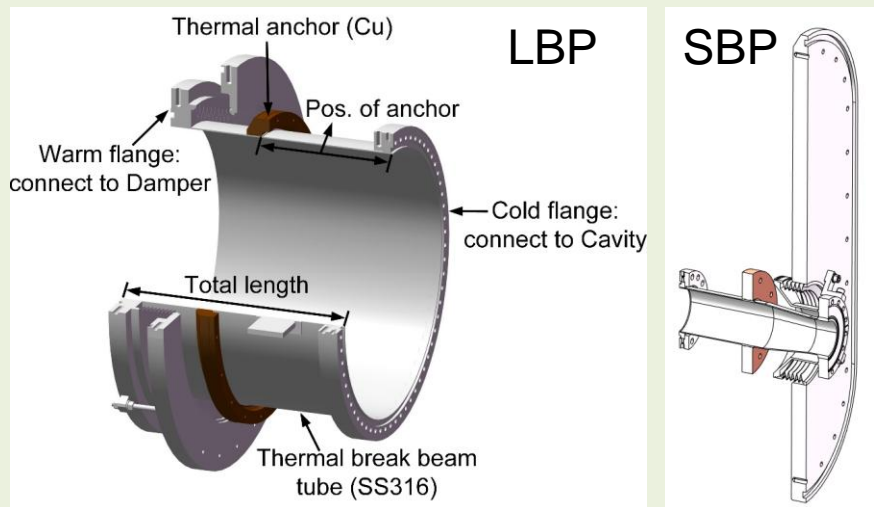

Structural parameters and simulation results

Parameters	LBP side	SBP side	Unit
Total length	440	284	mm
Wall thickness	2.5	1.5	mm
Position of thermal anchor	260	120	mm
Temperature of warm flange	290	288	K
Static heat load to 4 K	6.2	1.3	W
Static heat load to 80 K	87	6.1	W
Peak von Mises stress	49	11	MPa
Buckling load factor	24	207	-

- Aperture (505 mm to 63 mm)
- Collimating from 63 mm to 45 mm is required to create shadows for downstream components

Parameter	Value
$\Phi$ of collimators (mm)	45
Spot length/height (mm)	34.5/0.7
Angle ( $^\circ$ )	0.182
Safety distance (mm)	5
Irradiated power (W)	238
Power density ( $W/mm^2$ )	11.63
$k_{//}$ (V/pC)	5.324

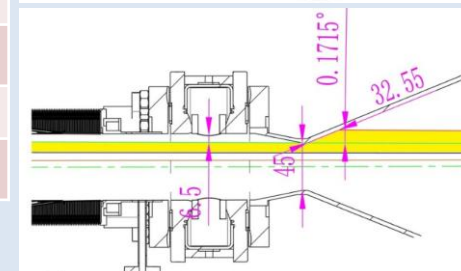
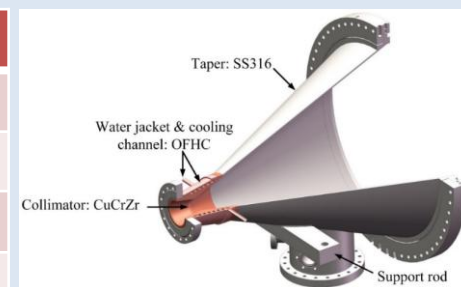

Max temp. on the spot of SR incidence: 64 °C

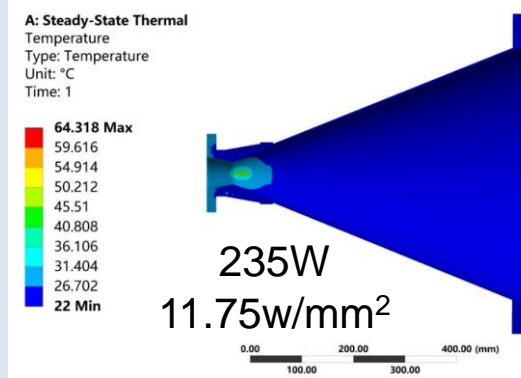

# Magnetic shielding

- Cavity beam axis placed in the east-west direction
- Magnetic shielding consists of **two layers**, one outside of the jacketed cavity at 4.2 K to prevent interference with LHe flow, and the other inside the cryostat at room temp. to enhance shielding performance
- Maximum residual magnetic field measured inside the inner shielding region was **30 mG**, met the specified 40 mG and consistent with simulation predictions

Locations of SRF cavities at HEPS

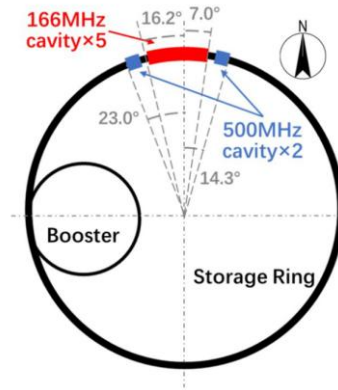

Shield at room Temp.  
permalloy 1J85

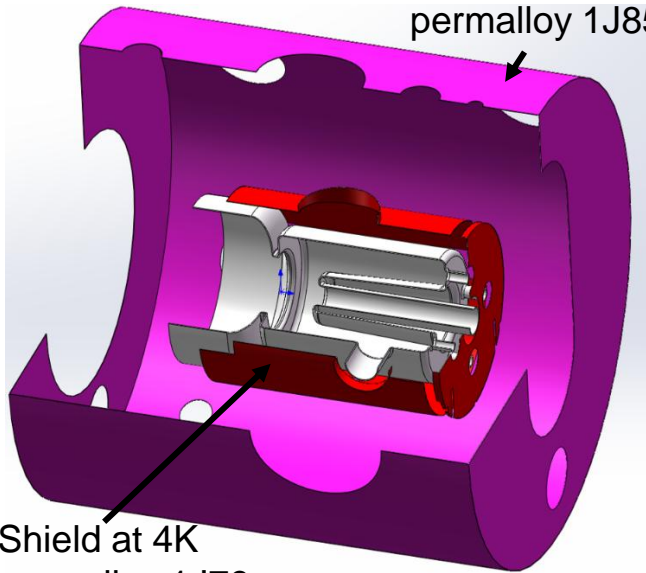

Shield at 4K  
permalloy 1J79

Residual magnetic field on the cavity

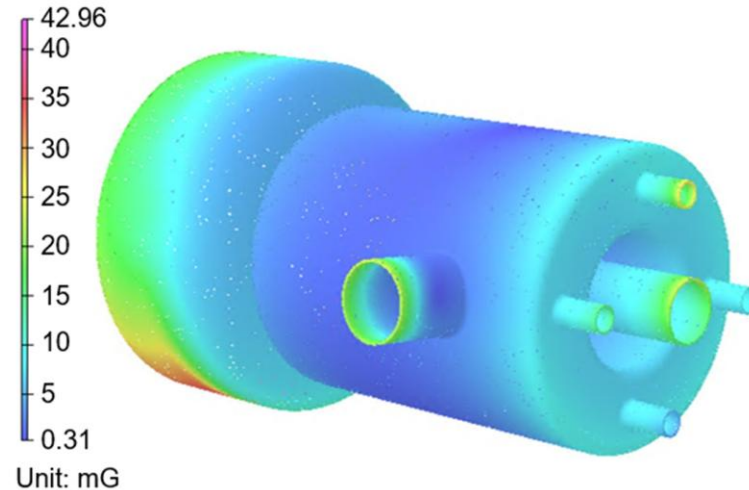

Magnetic field measurements

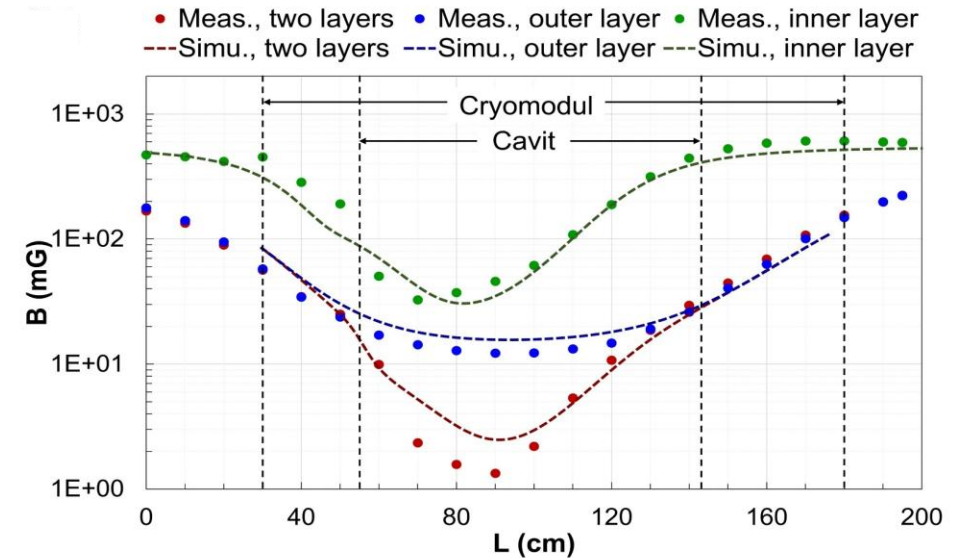

# Frequency control and frequency tuning

- 166.6 MHz cavities require precise frequency control throughout the entire production, treatment, assembly, and operation process
- **All five cryomodules were successfully tuned to 166.6 MHz at 4.2K**

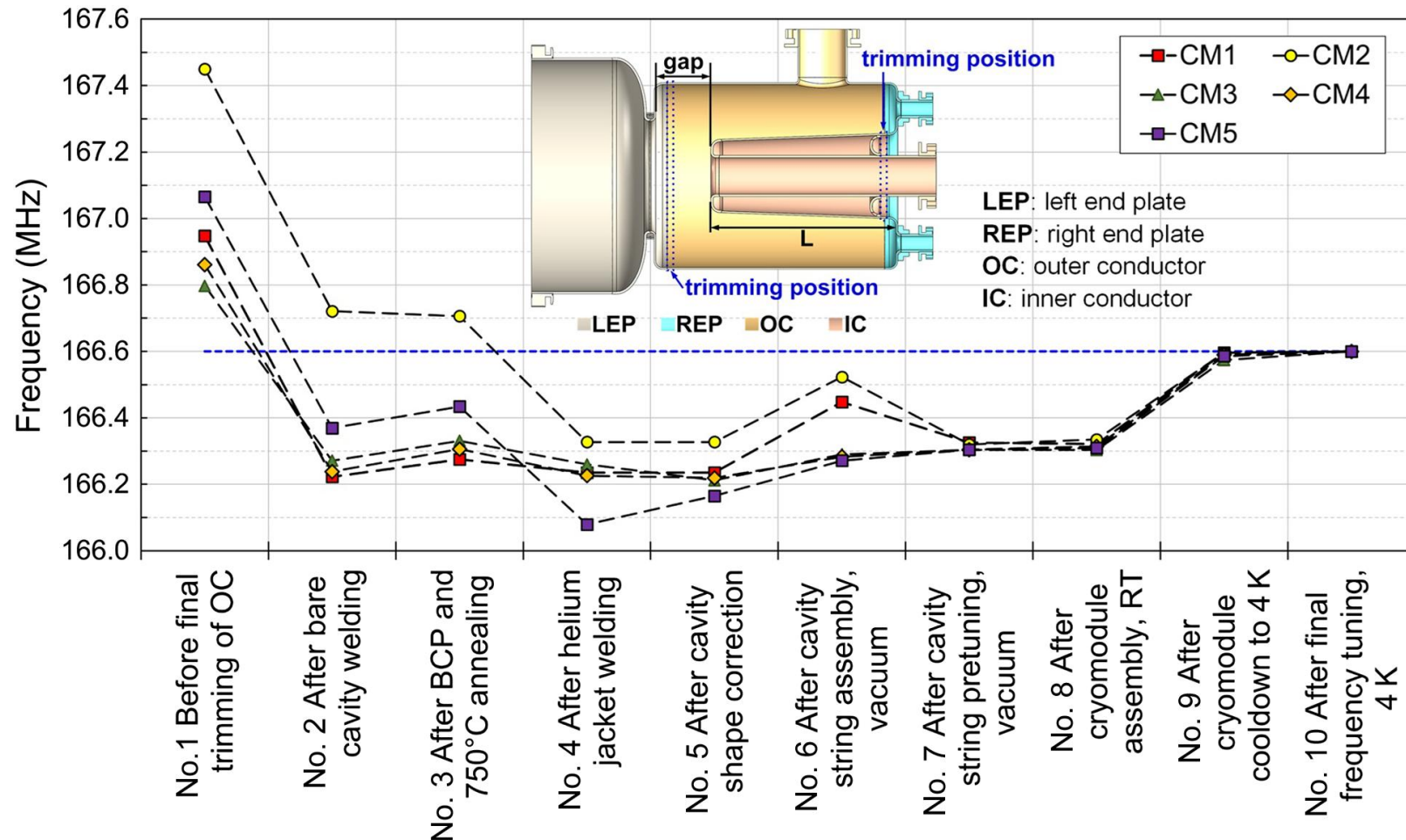

Tuner system mounted on the cryomodule's endplate and connected to the large transition beam tube

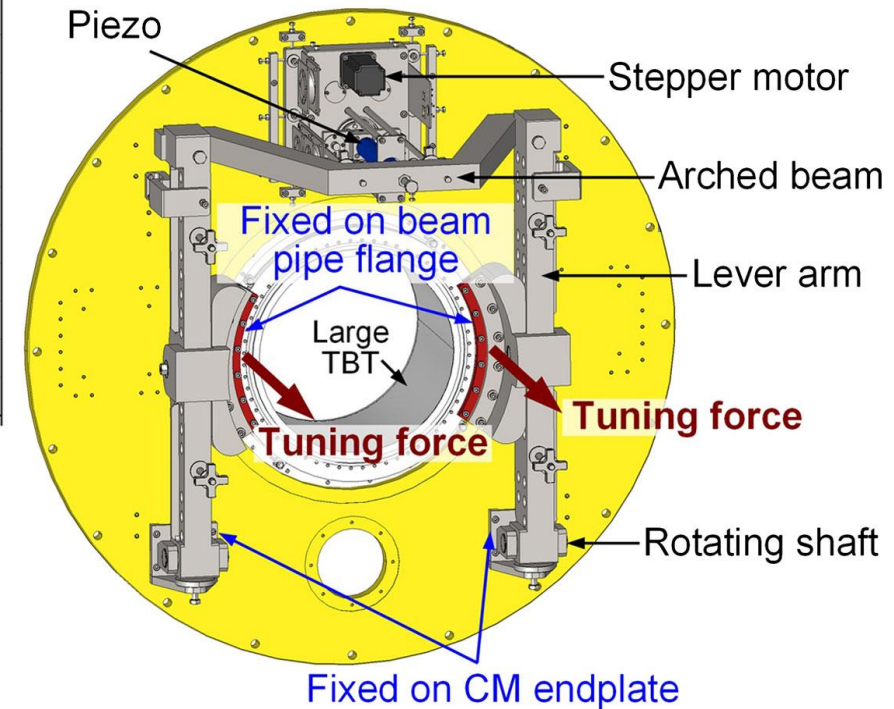

# Cryostat: mechanical reinforcement

- Exceptional cavity movement under tuning force & vacuum force observed on CM01
- Cavity end plate fixed by SS triangular plate on support posts. Additional reinforcement connecting the cavity to the cryostat and the support posts was implemented to mitigate cavity movement
- The design ensures that 60% of the tuning displacement measured on the large beam pipe (LBP) can be utilized for cavity deformation, reduced tuning sensitivity, requiring precise freq. control

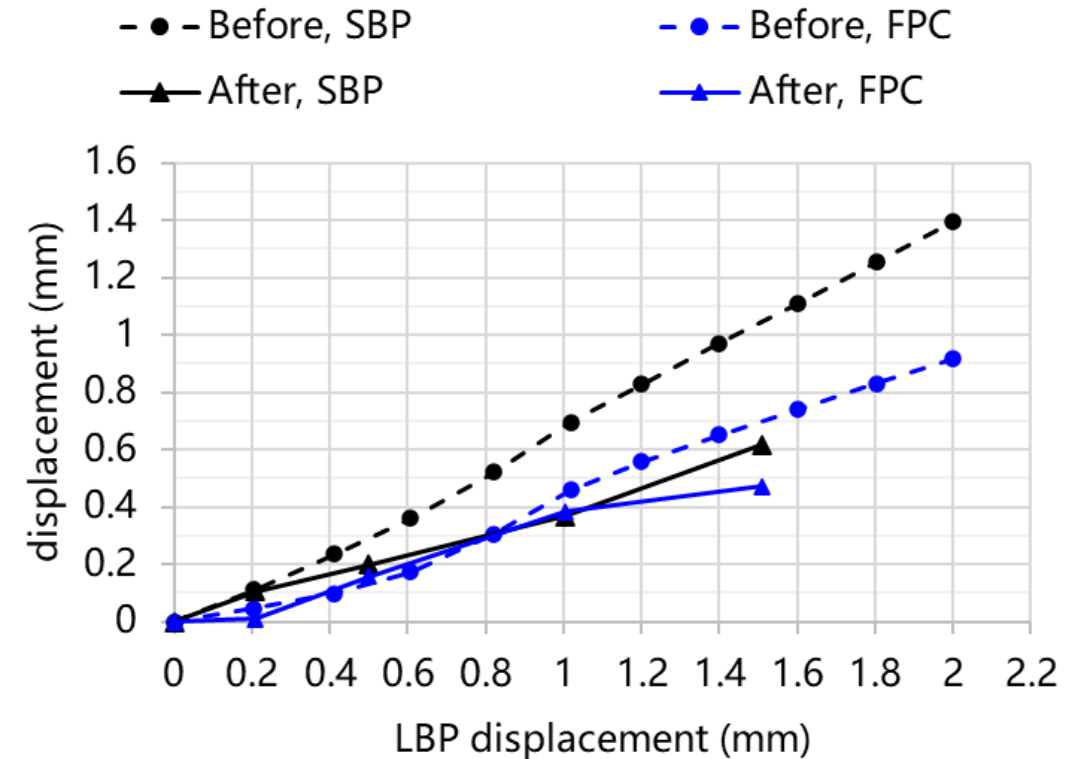
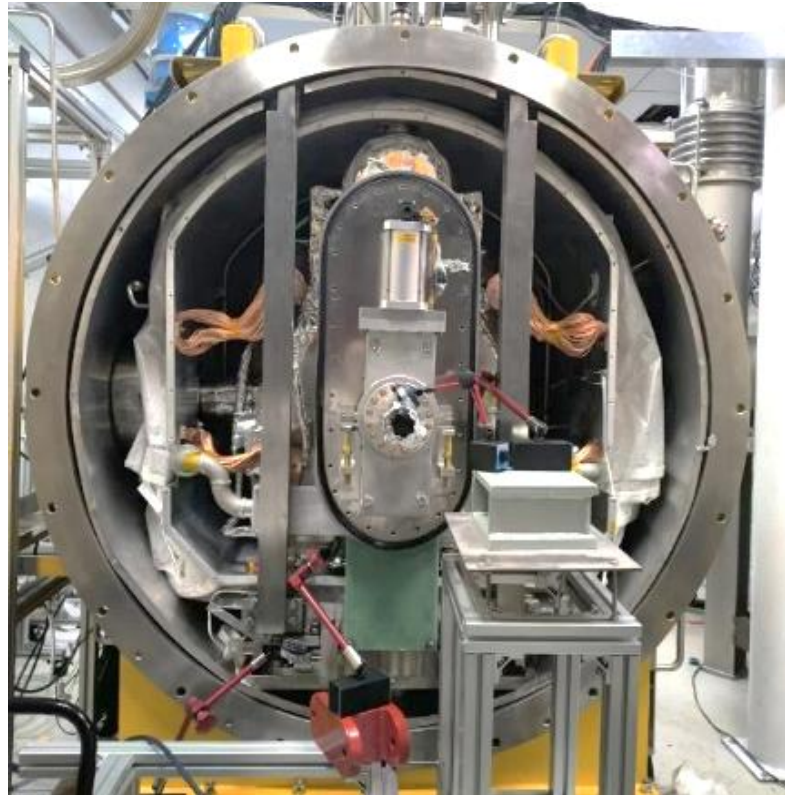
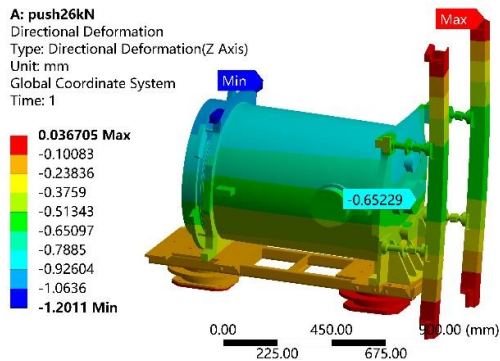
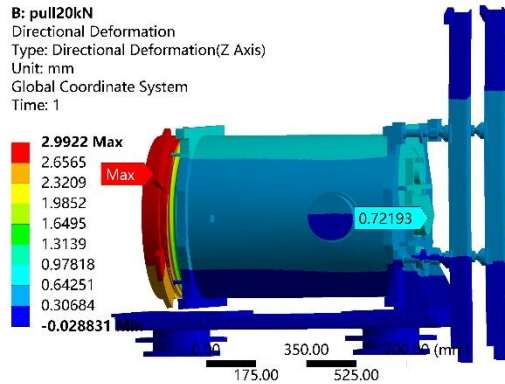

# Displacement during cooldown/warmup

- The displacements of the beam pipes and the FPCs during both cooldown and warm-up processes were measured using digital indicators mounted for all five cryomodules
- These displacement values subsequently used for module alignment inside the HEPS tunnel
- Shielded bellows installed on each side of the cavity string are used to compensate some of these displacements (in addition to alignment allowance)

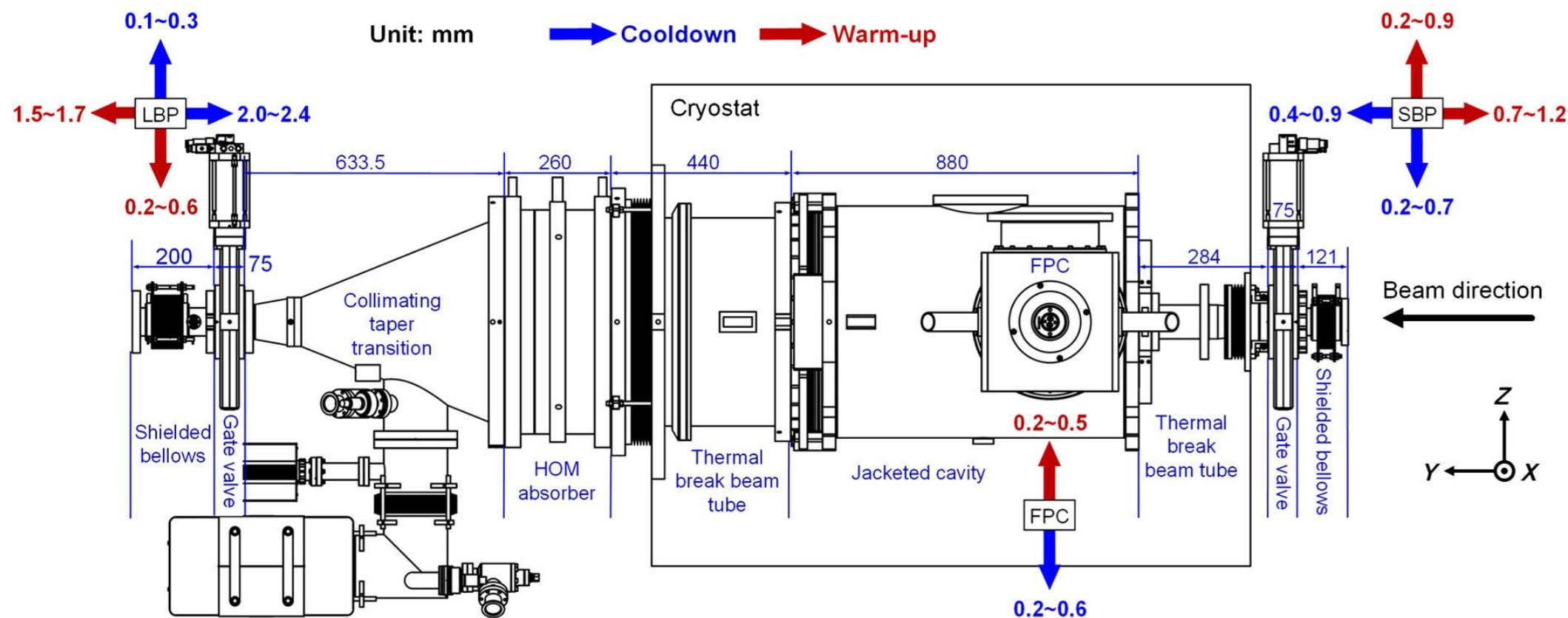

# False arc events: beam loss induced

- FPC of each cavity is equipped with one dual-channel arc detector
- **False arc events** dominated RF interlocks during initial commissioning of BS and SR
- **Observations:** False arc events often accompanied by beam loss (due to unstable orbit), but did NOT present typical features of a real arc:
  - vacuum deterioration, reflected power fluctuation, electron current, heating
- **Validation** experiments confirmed: tunnel arc frequently triggered, and often associated with beam instabilities
- **Cause:** beam loss induced X-rays, generate real optical signals inside the optical fibers
- **Impact:** degraded optical fiber sensitivity, increased RF system trip rate

20250811~20251029, HEPS interlock events (RF recorded)

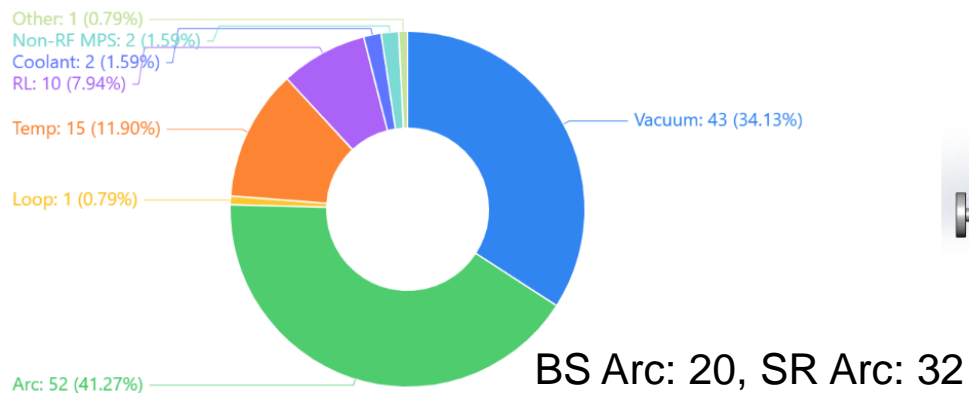

Original arc detection setup (before 2025.11.12)

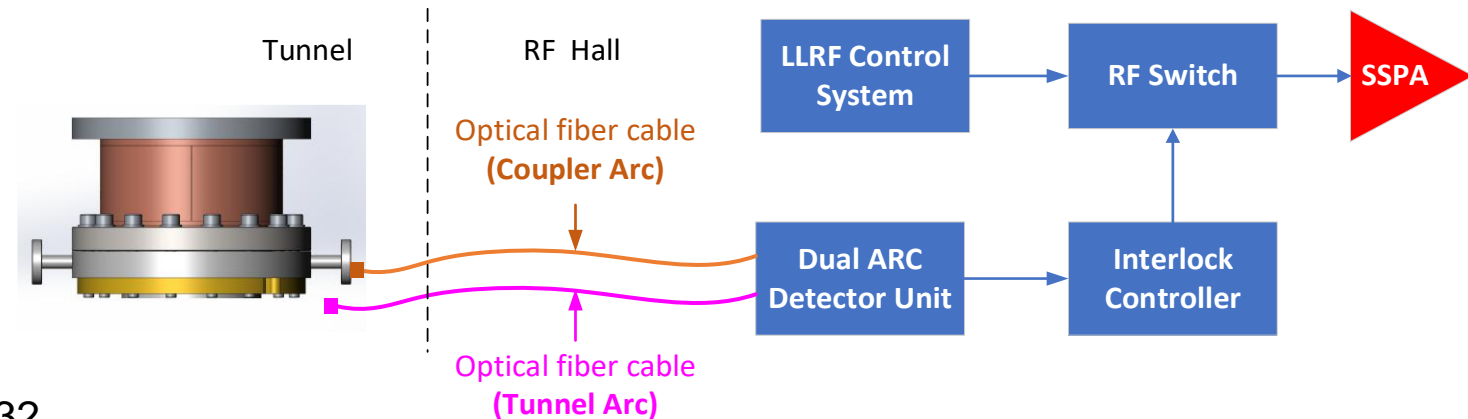

# Mitigation of false arc events

- **Solution 1: logic-based arc discrimination (implemented)**
  - Interlock rule: FPC\_arc = “Y” AND Tunnel\_arc = “N”
  - Implemented in Nov. 2025, false arc events **significantly reduced**, proven effective
- **Solution 2: modified fiber configuration (plastic optical fiber + low-loss optical fiber)**
  - Radiation-hard plastic optical fiber for high-radiation zone (inside tunnel, 10 meters, higher loss)
  - Low-loss multimode optical fiber for low-radiation zone (outside tunnel, 30 meters)
  - Procurement underway, to be implemented during the next long shutdown

20250811–20251029 SR & BS interlock events (RF recorded)

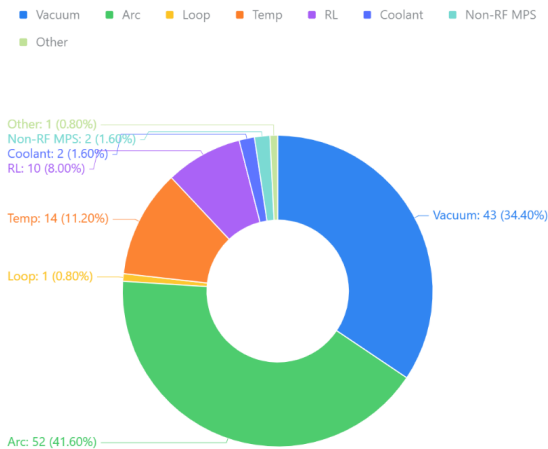

Normal arc interlock

20260101–20260315 SR & BS interlock events (RF recorded)

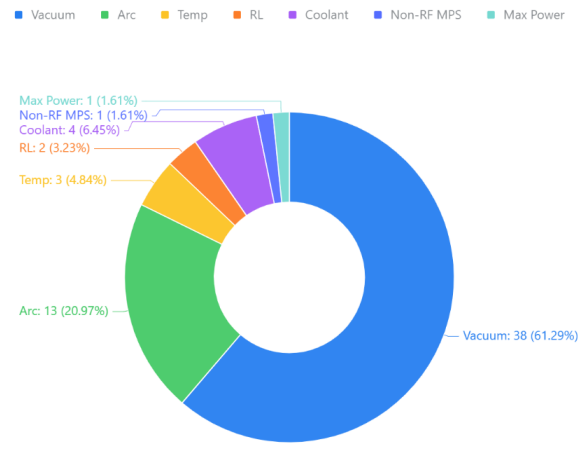

Logic-based arc interlock

## Current arc detection setup (after 2025.11.12)

