

ED PHENIICS

Understanding basic principles of particle accelerators

Zoom on the LHC

Nicolas Delerue

IJCLab (CNRS and Université de Paris-Saclay)



THE LHC

Note: most slides from today lecture are taken from seminars and conference presentation by others. In particular: F. Zimmerman, M. Lamont, M. Thomson...

short LHC history

1983 LEP Note 440 - S. Myers and W. Schnell propose twin-ring pp collider in LEP tunnel with 9-T dipoles

1991 CERN Council: LHC approval in principle

1992 EoI, LoI of experiments

1993 SSC termination

1994 CERN Council: LHC approval

1995-98 cooperation w. Japan, India, Russia, Canada, & US

2000 LEP completion

2006 last s.c. dipole delivered

2008 first beam

2010 first collisions at 3.5 TeV beam energy

2015 collisions at ~design energy

we are already late if we want

to get a new machine by ~2040!

>30 years!



PRELIMINARY PERFORMANCE ESTIMATES FOR A LEP PROTON COLLIDER

S. Myers and W. Schnell

A complex enterprise

- Beyond the particle physics challenges associated with the construction of the detectors and the analysis of the data, building and operating the LHC machine was also an immense challenge involving a large number of skills.
- Such machine usually takes several years to reach its full potential and the engineers running it improve its performance all the time.

References: <http://lhc.web.cern.ch/lhc/LHC-DesignReport.html> and

« The LHC Machine, Lyndon Evans and Philip Bryant 2008 *JINST* **3** S08001 doi:10.1088/1748-0221/3/08/S08001 »

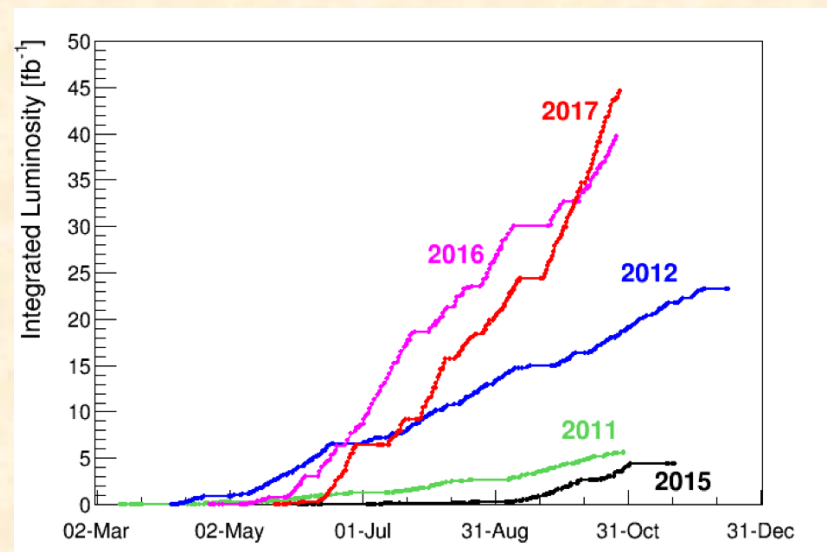
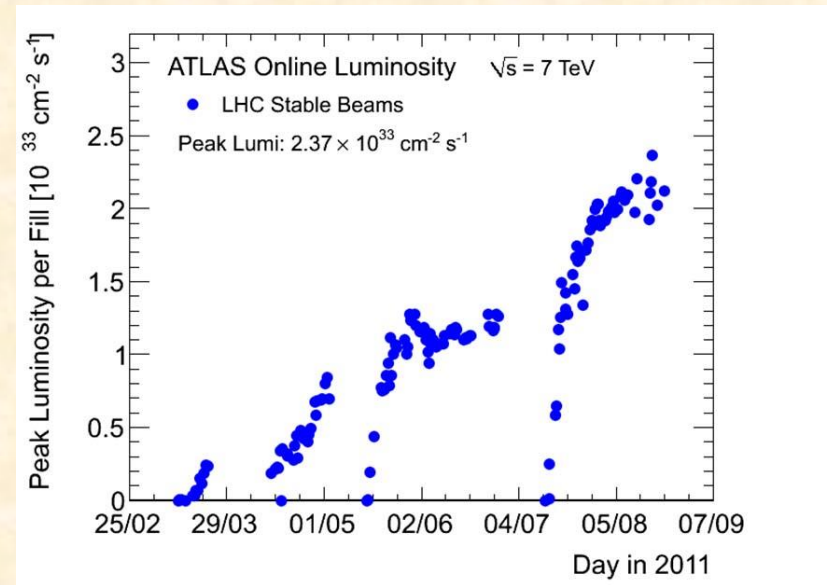

Proton source

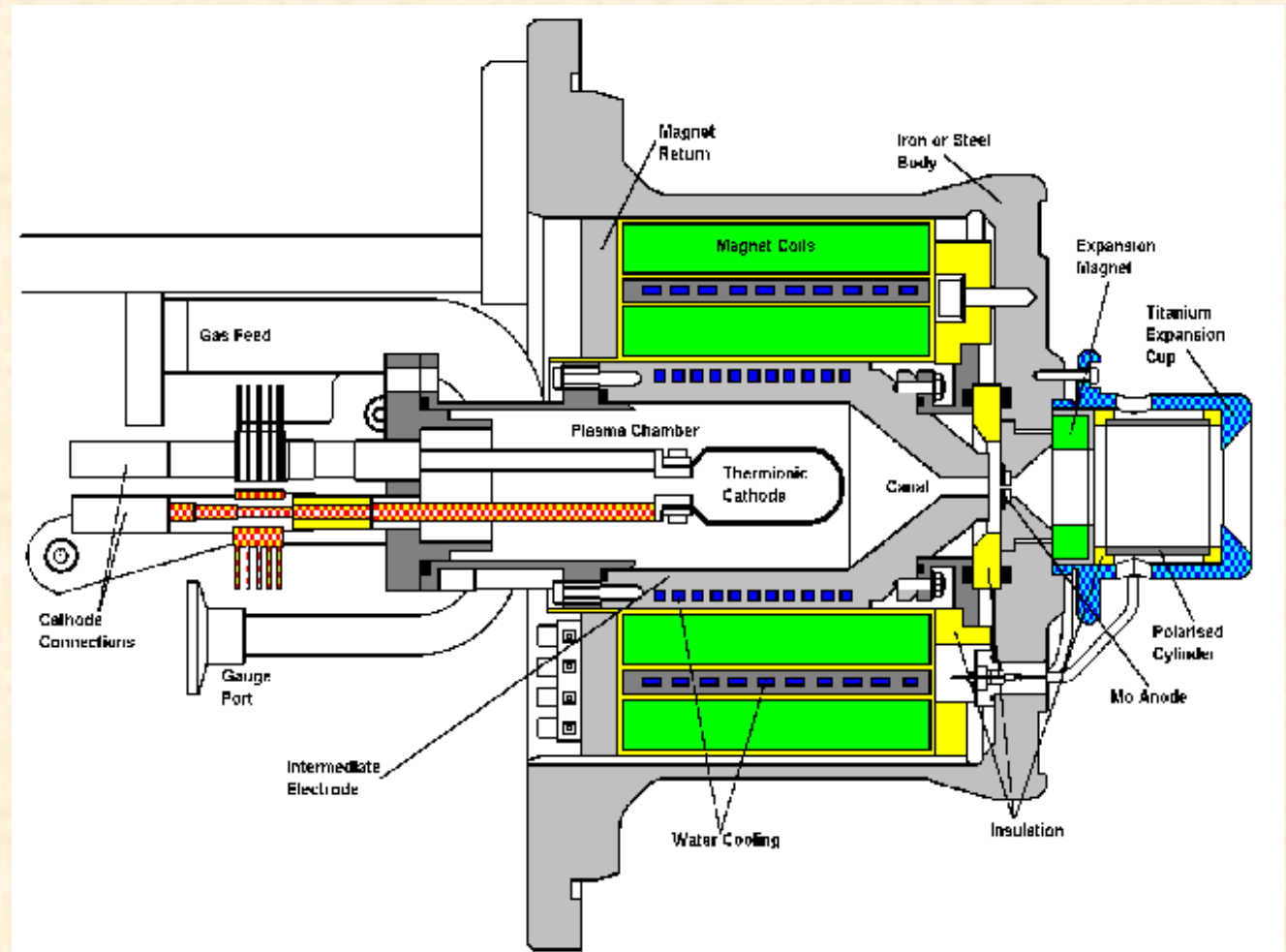

- Particles are extracted by ionisation of hydrogen as in a device called “Duoplasmatron Proton Ion source”

Linac

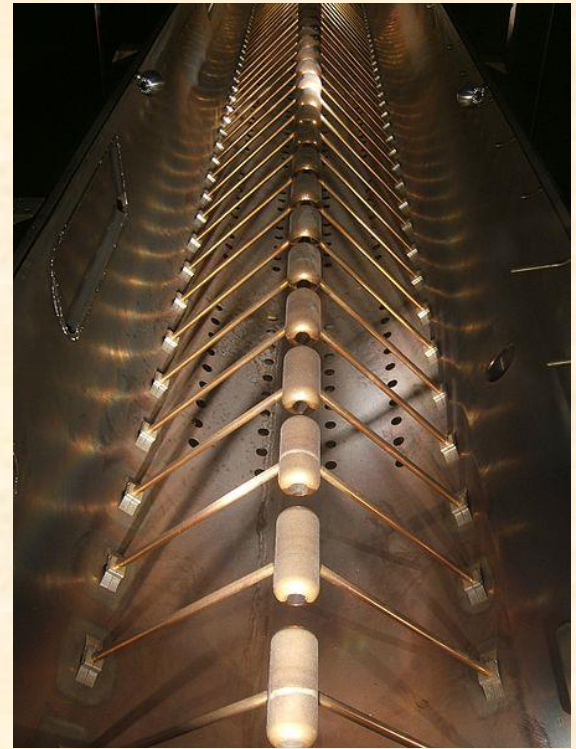
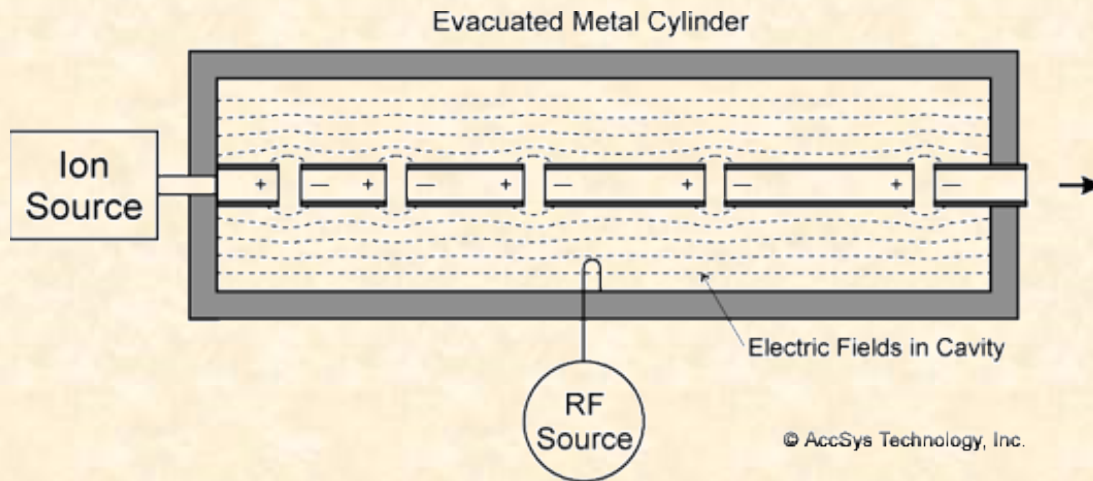

- After the source the protons are accelerated in a linac.
- As the protons gain speed they travel longer distance in a RF cycle and therefore the length of the tubes must be increased.
- At the end of the Linac the protons reach an energy of 50 MeV.



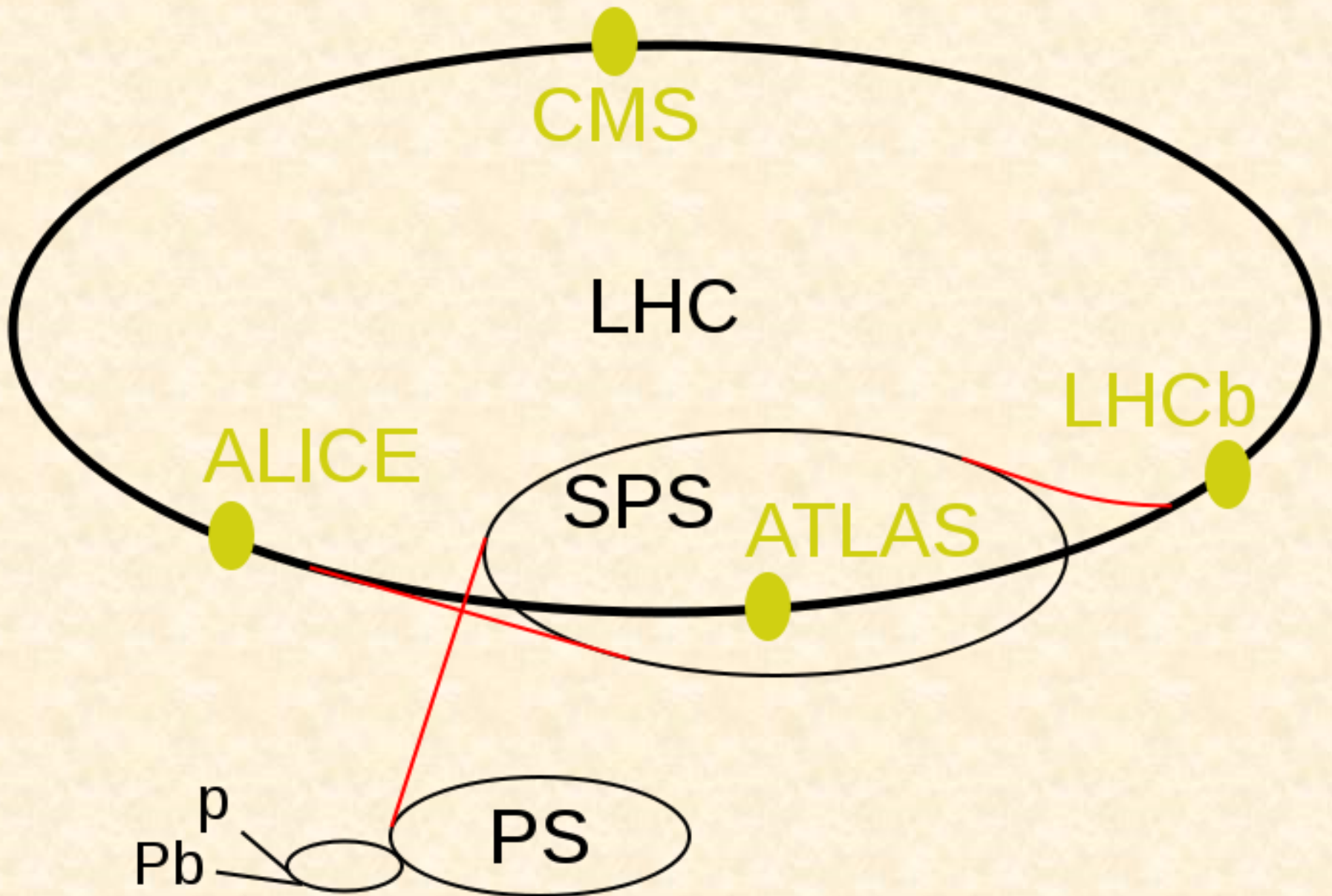

Pre-acceleration rings

- At 50 MeV the energy of the protons is too low to be injected in the LHC.
- Several intermediate rings are necessary to bring their energy to the LHC injection energy.
- To save space the first of these rings, the PS booster is made of 4 rings stacked on to each other!
- All these rings use pulsed magnets which allow to change the beam configuration very quickly.
- The PS was built in 1959, the PSB in 1972 and the SPS in 1976.

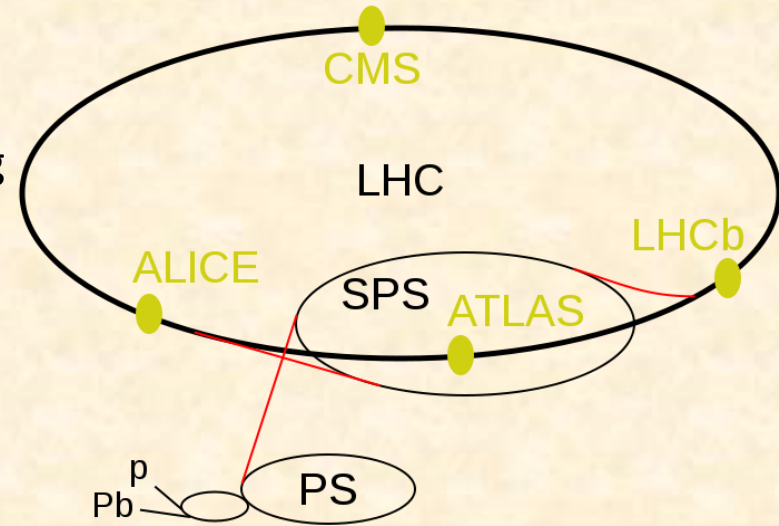

Why pre-acceleration rings?

- In a synchrotron the strength of the magnets must be increased when the energy of the particles is increased.
- It is cheaper to have magnets (and power supplies) with a limited dynamic range.
- As the energy of the beam increases its emittance (and therefore its size) decreases.

Early accelerators in the acceleration chain must have a wide aperture whereas the LHC has a small aperture (a bunch from the Linac would not fit in the LHC).

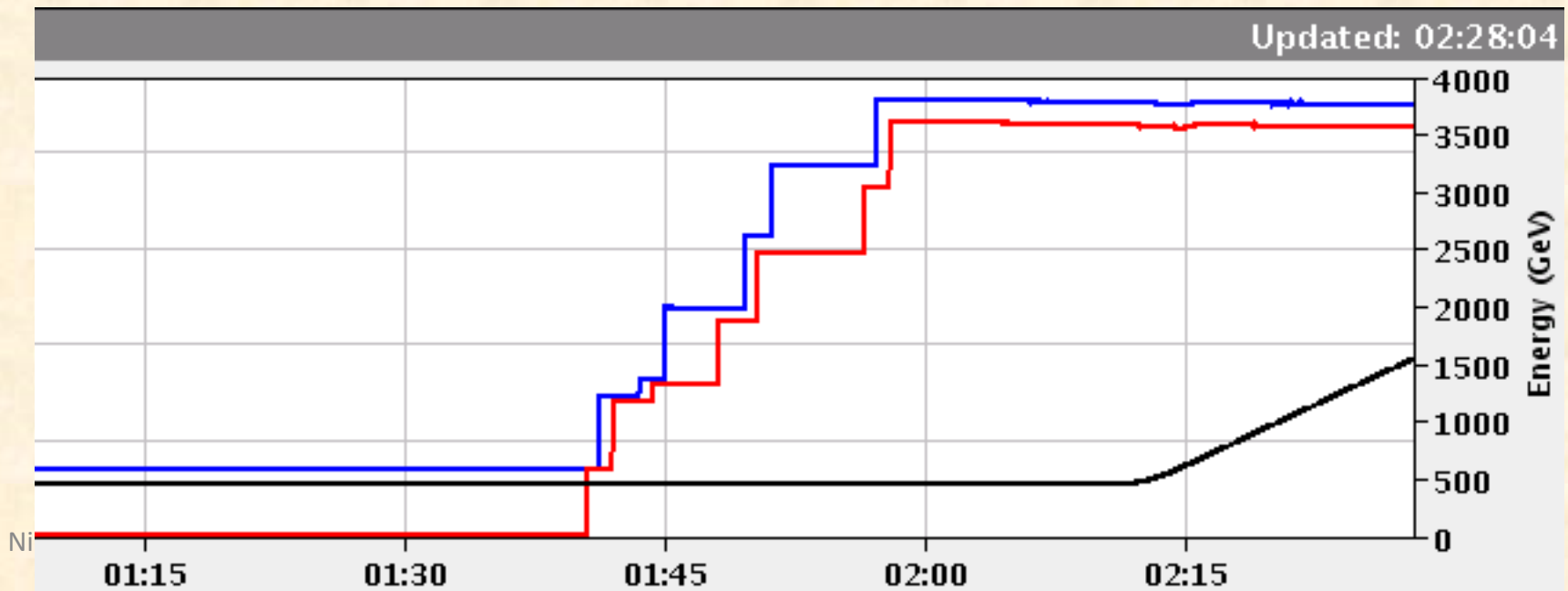

Protons bunch splitting

- Another purpose of the PS is to adapt the bunch structure from the Linac to the requirements of the LHC.
- The RF of the PS is used to split 8 proton bunches into 84 bunches!

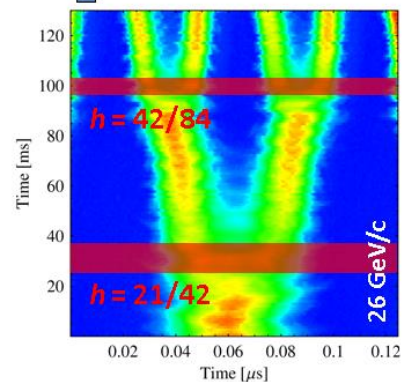
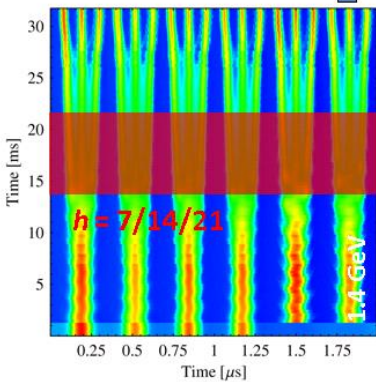
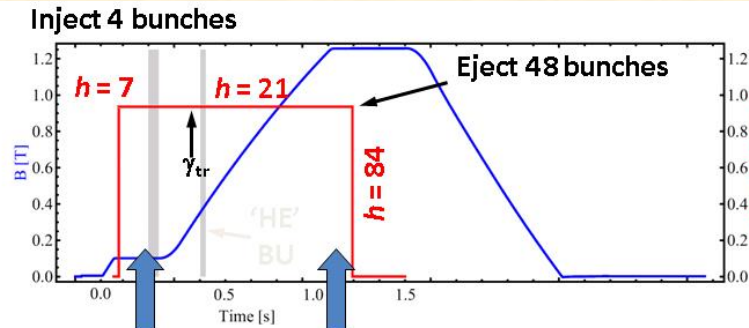

1. Inject four bunches

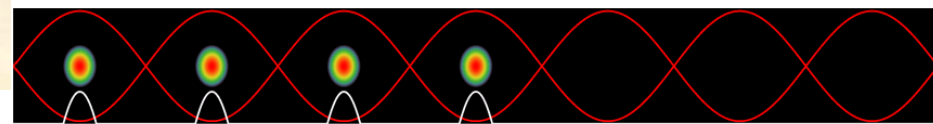

Wait 1.2 s for second injection

2. Inject two bunches

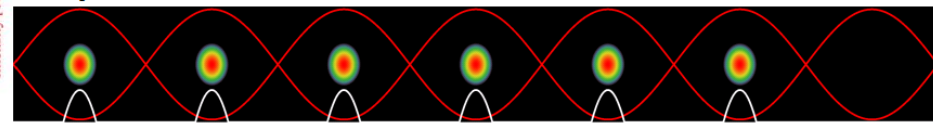

3. Triple split after second injection

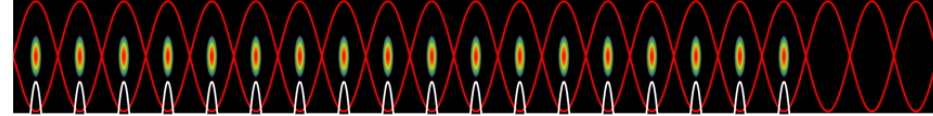

1. Coarse synchronization with SPS ($h1$, move batch)

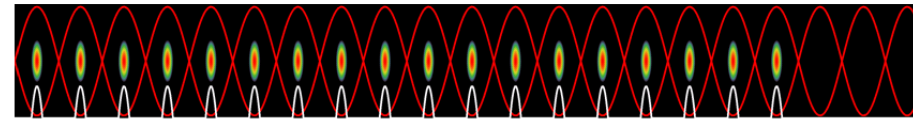

2. Double split ($h42 \rightarrow h84$)

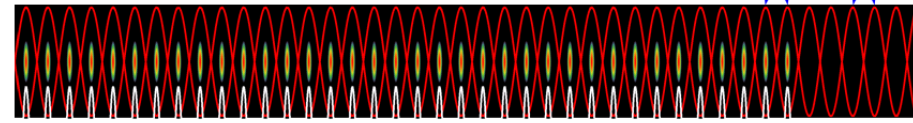

3. Fine synchronization, bunch rotation \rightarrow Extraction!

The LHC itself

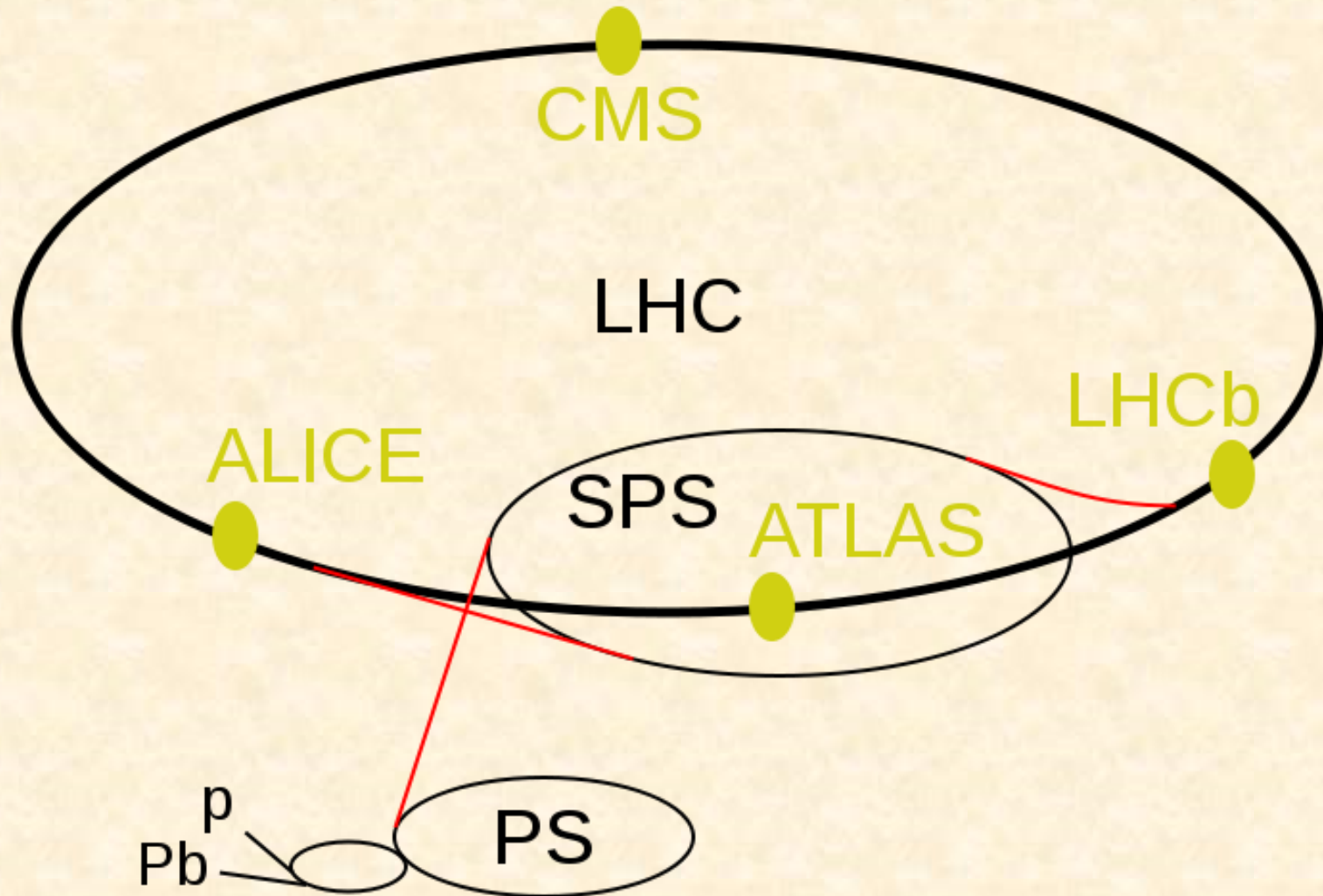

The LHC

- Circumference: 26659m
- Injection energy: 450 GeV
- 9300 magnets (1232 dipoles, 858 quadrupoles,...)
- Power consumption: 180MW

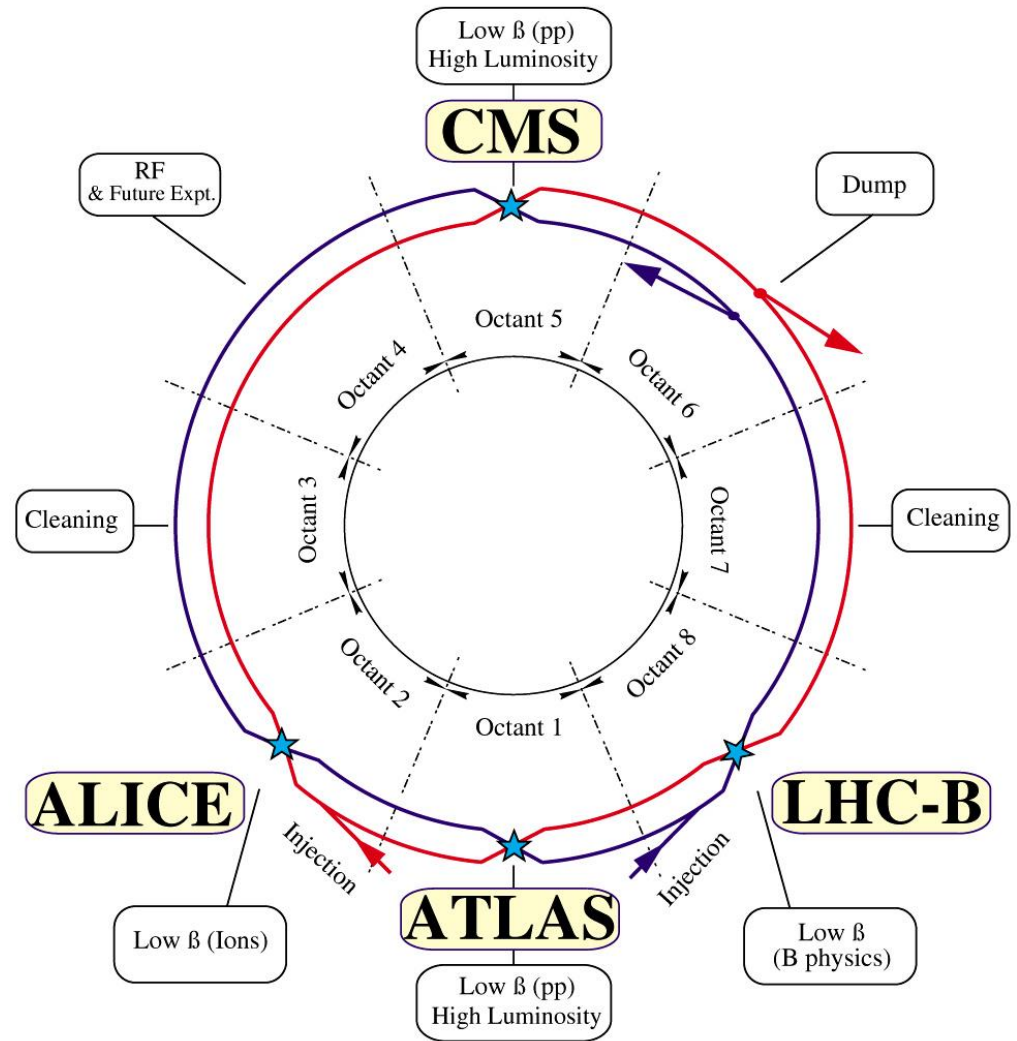

LHC: highest energy pp , AA , and pA collider

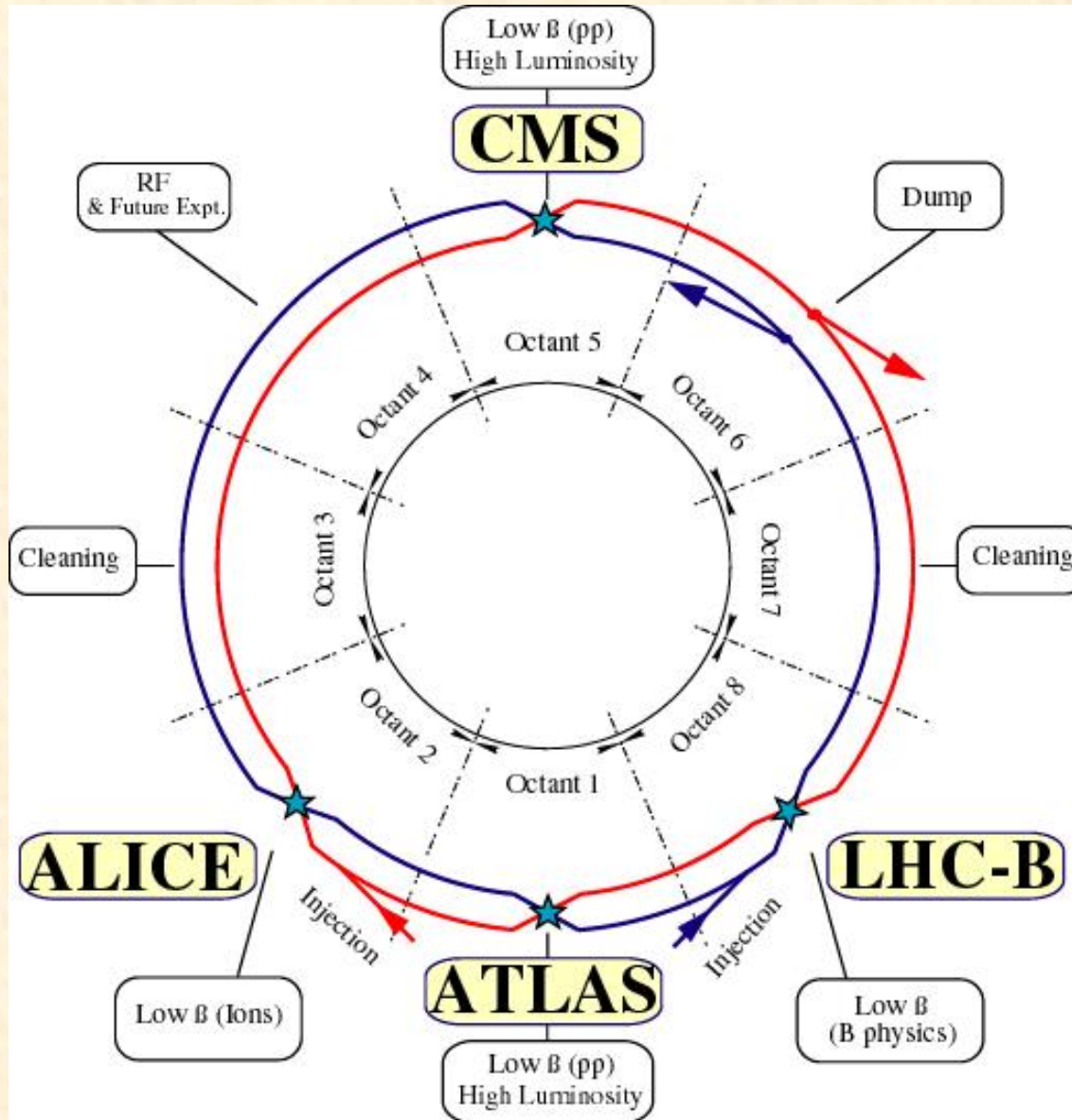

design parameters

c.m. energy = 14 TeV (p)
luminosity = 10^{34} cm $^{-2}$ s $^{-1}$

1.15×10^{11} p/bunch
2808 bunches/beam

360 MJ/beam

$\gamma\epsilon = 3.75$ μm
 $\beta^* = 0.55$ m
 $\theta_c = 285$ μrad
 $\sigma_z = 7.55$ cm
 $\sigma^* = 16.6$ μm

integrated pp luminosity

CMS Integrated Luminosity, pp

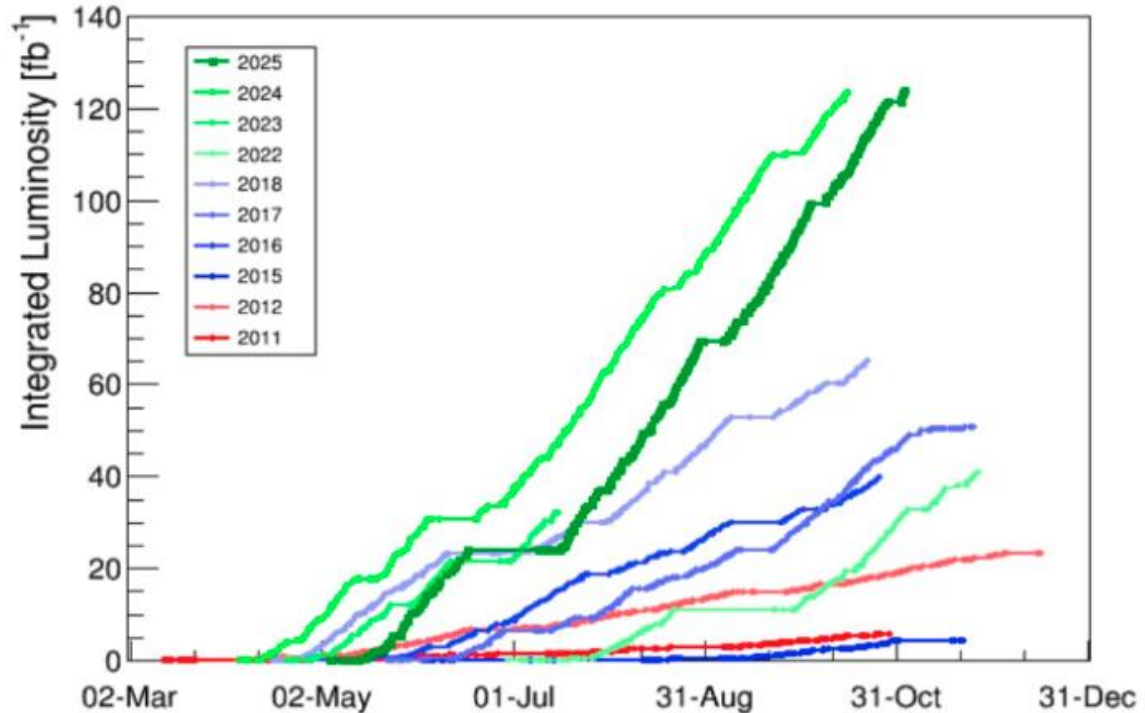
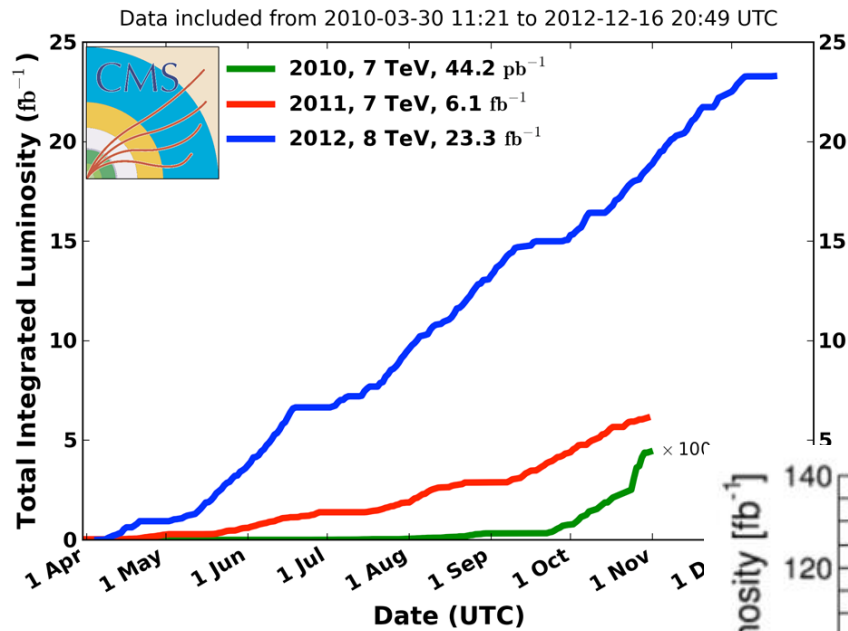

peak performance through the years

	2010	2011	2012	Nominal
bunch spacing [ns]	150	50	50	25
no. of bunches	368	1380	1380	2808
beta* [m] ATLAS and CMS	3.5	1.0	0.6	0.55
max. bunch intensity [protons/bunch]	1.2×10^{11}	1.45×10^{11}	1.7×10^{11}	1.15×10^{11}
normalized emittance [mm-mrad]	~2.0	~2.4	~2.5	3.75
peak luminosity [$\text{cm}^{-2}\text{s}^{-1}$]	2.1×10^{32}	3.7×10^{33}	7.7×10^{33}	1.0×10^{34}

>2x design when scaled to 7 TeV!

Quizz

- Suggest reasons to explain the limitations of the parameters in the table.

	2010	2011	2012	Nominal
bunch spacing [ns]	150	50	50	25
no. of bunches	368	1380	1380	2808
beta* [m] ATLAS and CMS	3.5	1.0	0.6	0.55
max. bunch intensity [protons/bunch]	1.2×10^{11}	1.45×10^{11}	1.7×10^{11}	1.15×10^{11}
normalized emittance [mm-mrad]	~2.0	~2.4	~2.5	3.75
peak luminosity [$\text{cm}^{-2}\text{s}^{-1}$]	2.1×10^{32}	3.7×10^{33}	7.7×10^{33}	1.0×10^{34}

Answer

- Bunch spacing: if the bunches are too close they affect each other with their wake.
- Beta: if the bunches are too small, internal effects (space charge, IBS,...) can destroy the bunches...
- Intensity: It is difficult to accumulate charge in a bunch. Losses all along the injection chain must be well controlled.

$Z \rightarrow \mu\mu$ event from 2012 data with 25 reconstructed vertices

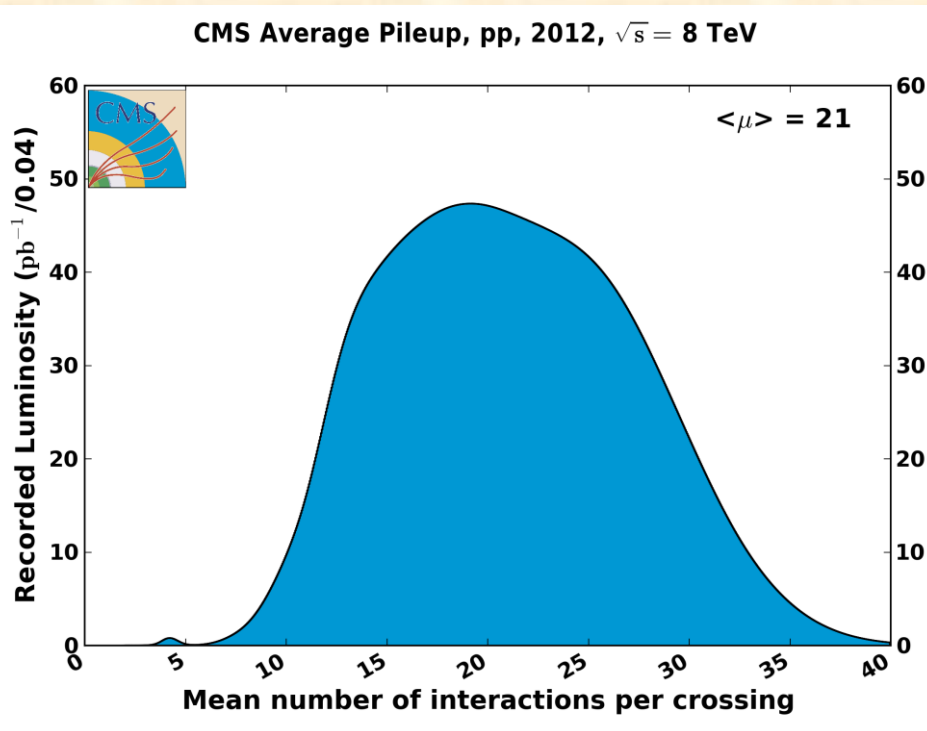
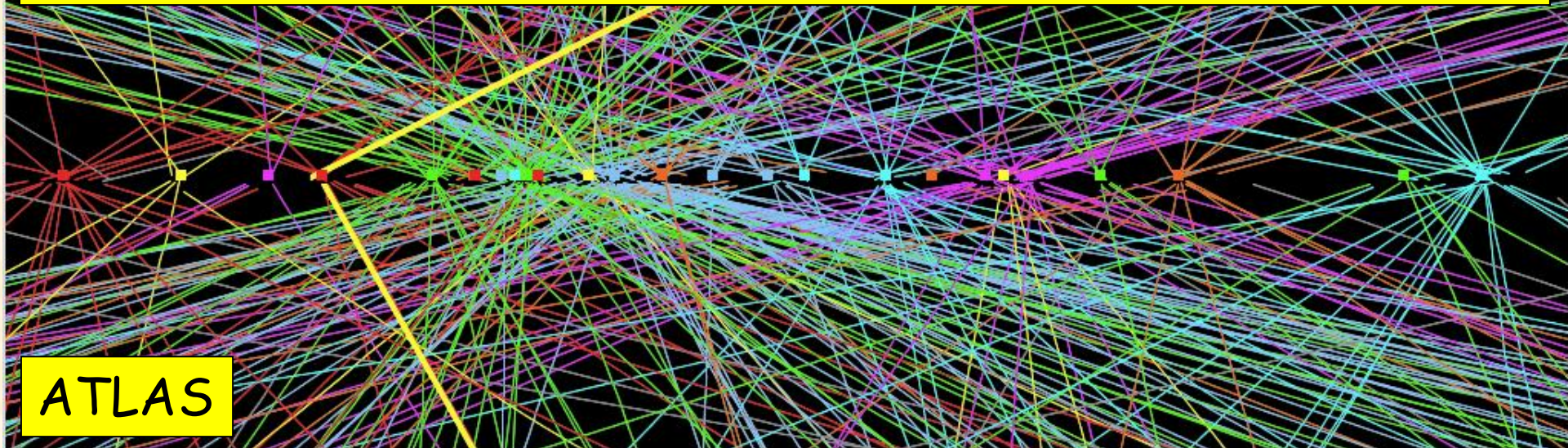

pile up
will increase
at higher energy
→
experiments
request
25 ns
operation
in 2015

LHCb

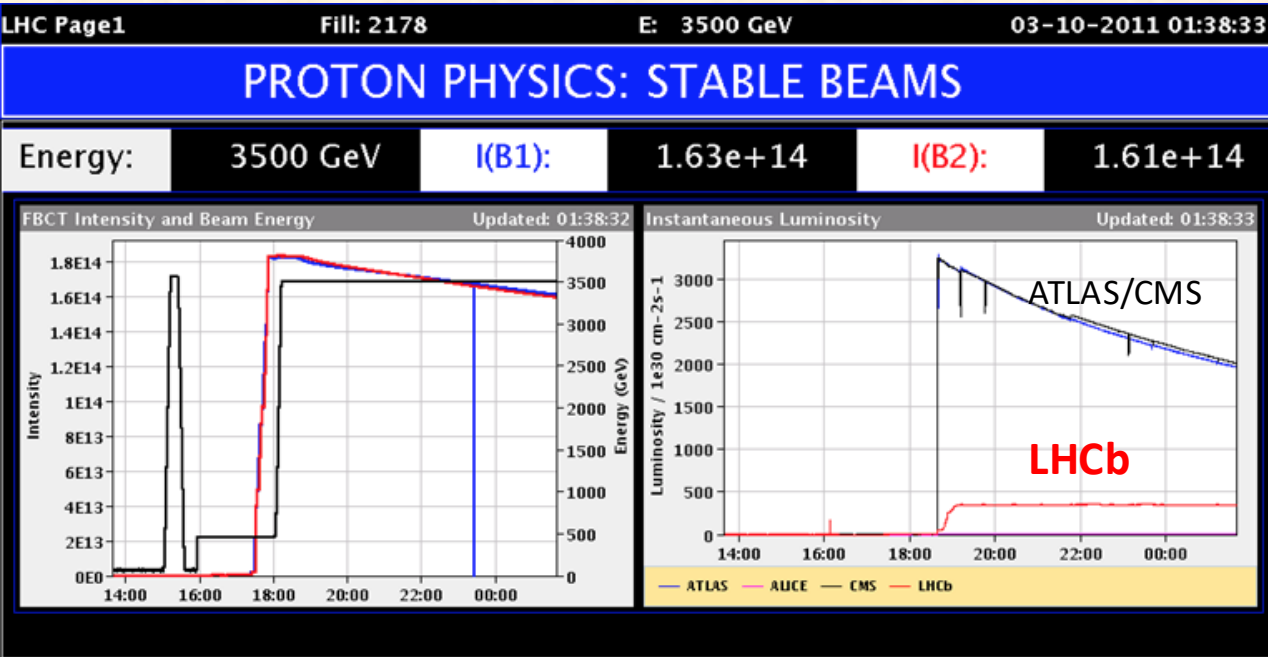

luminosity levelling at around $4e32 \text{ cm}^{-2}\text{s}^{-1}$ via transverse separation (with a tilted crossing angle)



not completely trivial!

Comments 03-10-2011 01:37:51 :

*** STABLE BEAMS ***

!!! CONGRATULATIONS TO LHCb !!!
!!! FOR THEIR 1ST 1.00/fb !!!

AFS: 50ns_1380b+1small_1318_39_1296_144bpi

BIS status and SMP flags	B1	B2
Link Status of Beam Permits	true	true
Global Beam Permit	true	true
Setup Beam	false	false
Beam Presence	true	true
Moveable Devices Allowed In	true	true
Stable Beams	true	true

PM Status B1: **ENABLED** PM Status B2: **ENABLED**

first evidence for the decay $B_s \rightarrow \mu^+ \mu^-$

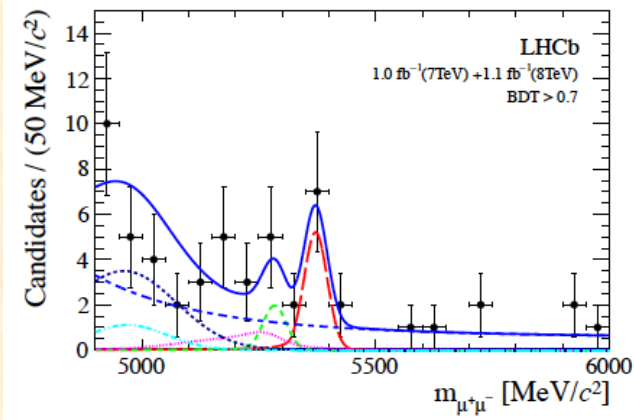

LHC injector complex

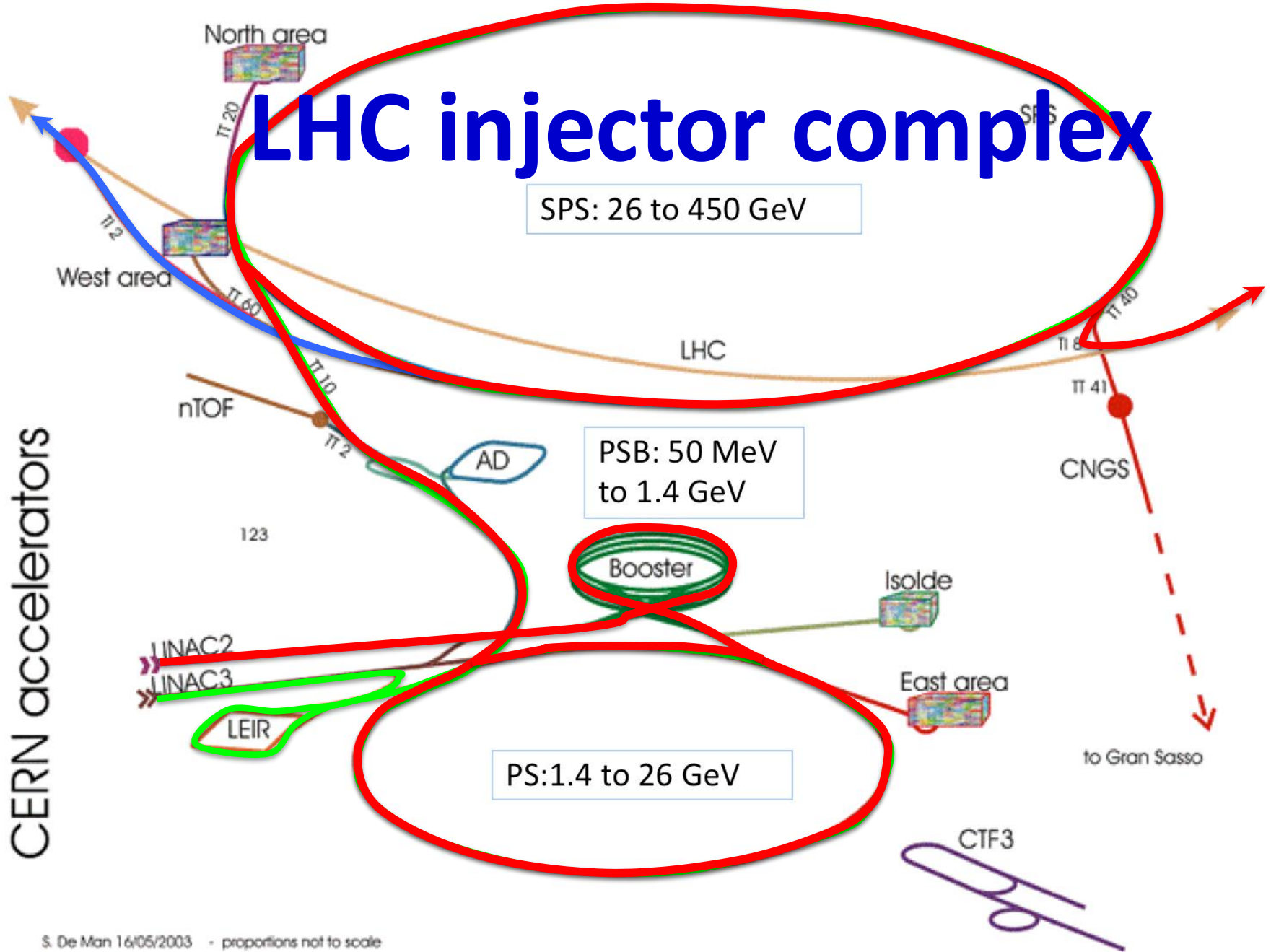

CERN accelerators

S. De Man 16/05/2003 - proportions not to scale

Pb-Pb

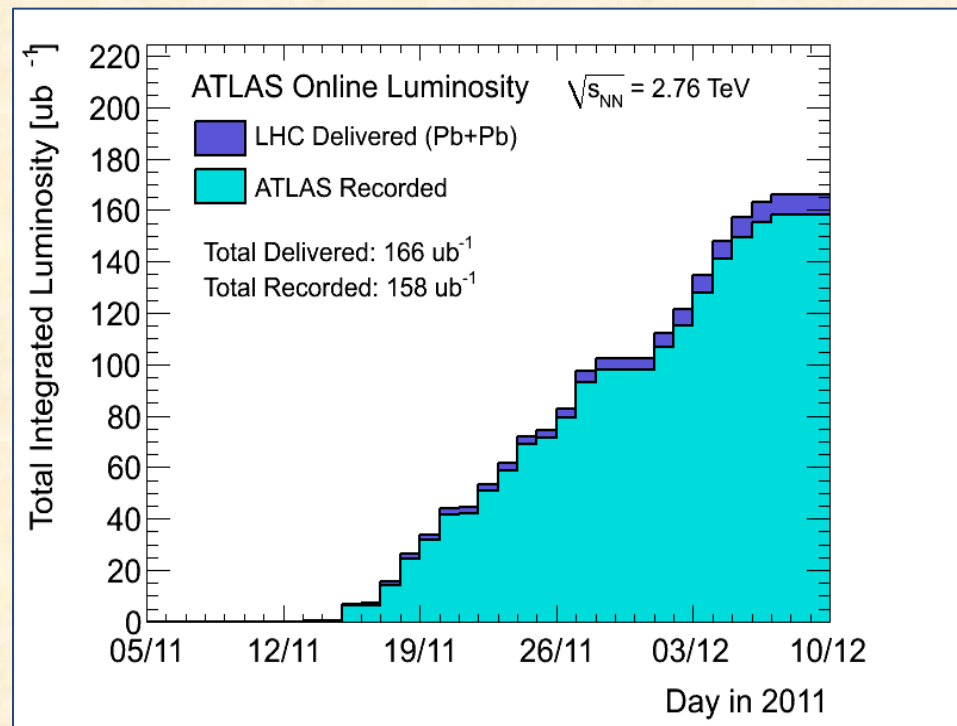
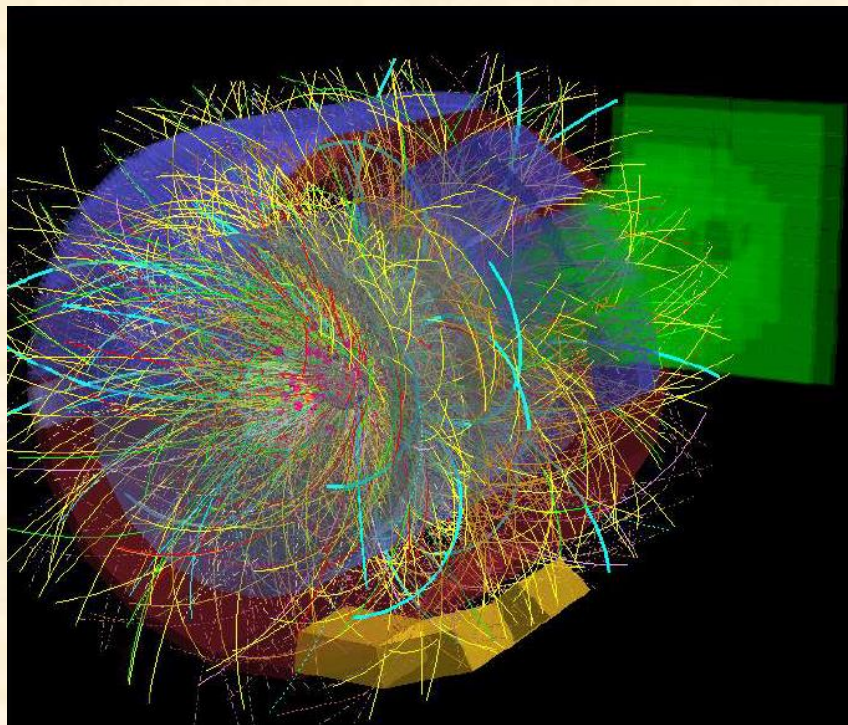

- good performance from the injectors - bunch intensity and emittance
- preparation, Lorentz' law: impressively quick switch from protons to ions
- peak luminosity around $5 \times 10^{26} \text{ cm}^{-2}\text{s}^{-1}$ at 3.5Z TeV (2011) – nearly twice design when scaled to 6.5Z TeV

proton-lead

- beautiful result in early 2013
- final integrated luminosity above experiments' request of 30 nb^{-1}
- injectors: average number of ions per bunch was $\sim 1.4 \times 10^8$ at start of stable beams, i.e. around **twice the nominal intensity**

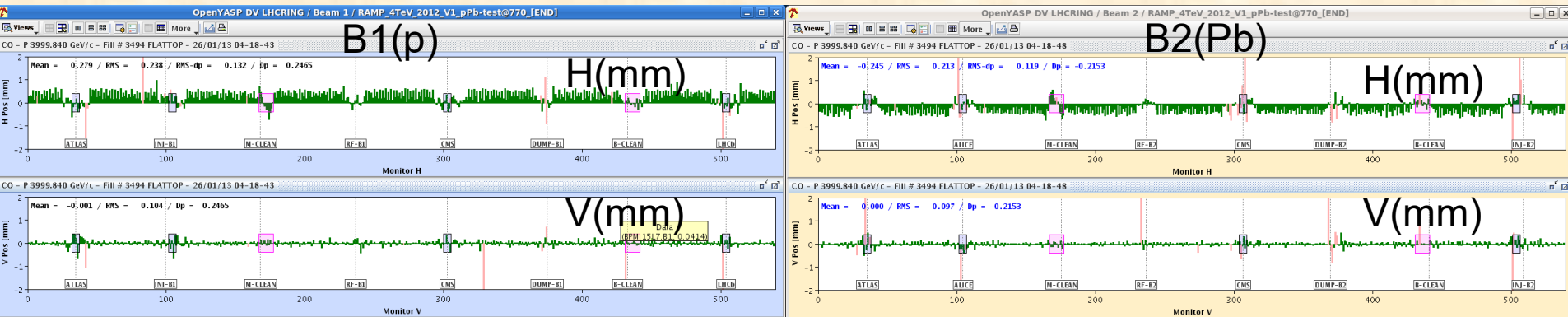

beam orbits at top energy with RF frequencies locked to Beam 1

operational cycle

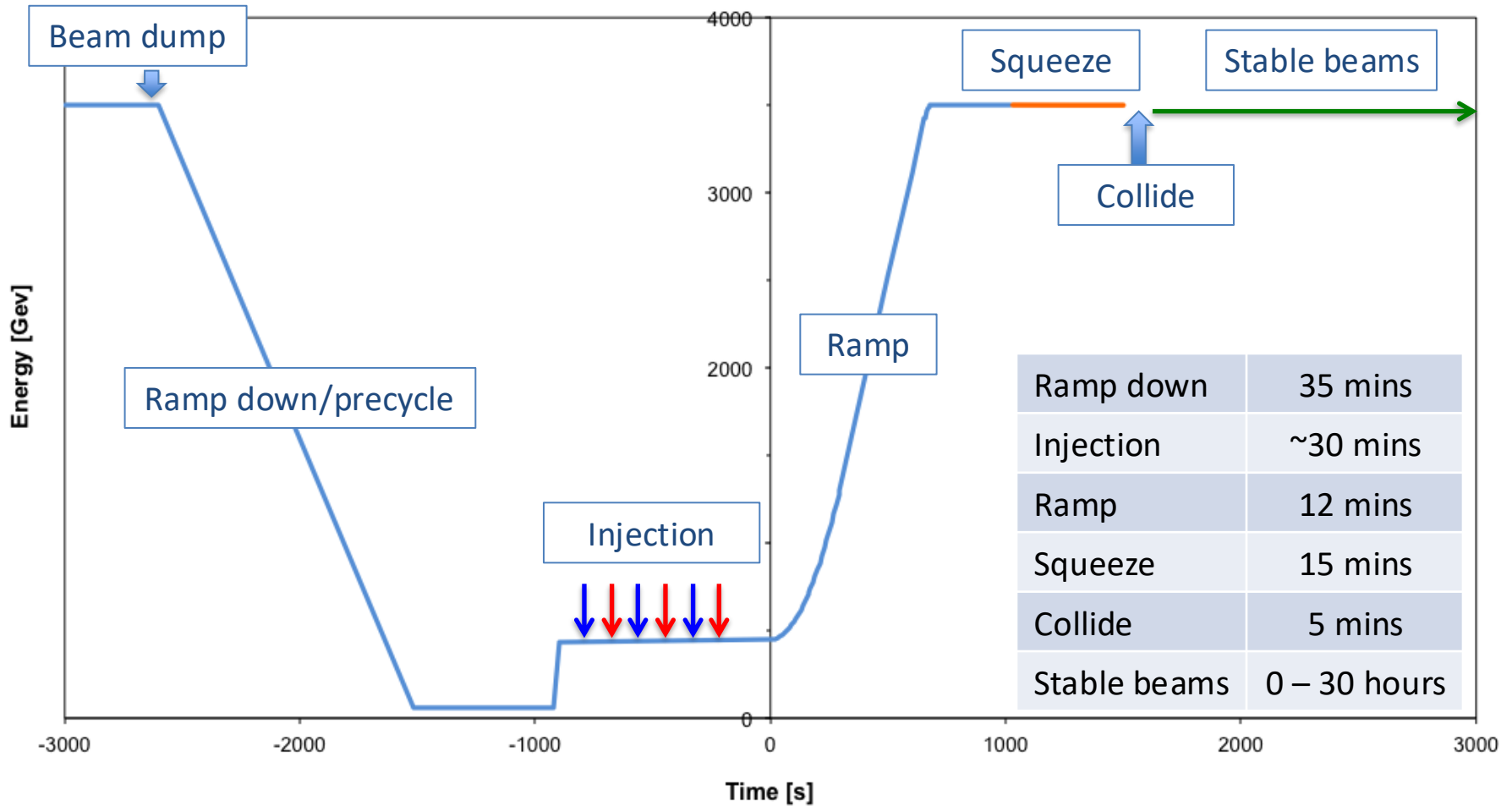

turn around 2 to 3 hours on a good day

availability

- “There are a lot of things that can go wrong – **it’s always a battle**”
- Pretty good availability considering the complexity and principles of operation

2012 Proton Run Efficiency

27.6%



13.8%

15.0%

2.1%

5.0%

36.5%

SB Time: 73.2 days Total Time: 200.5 days

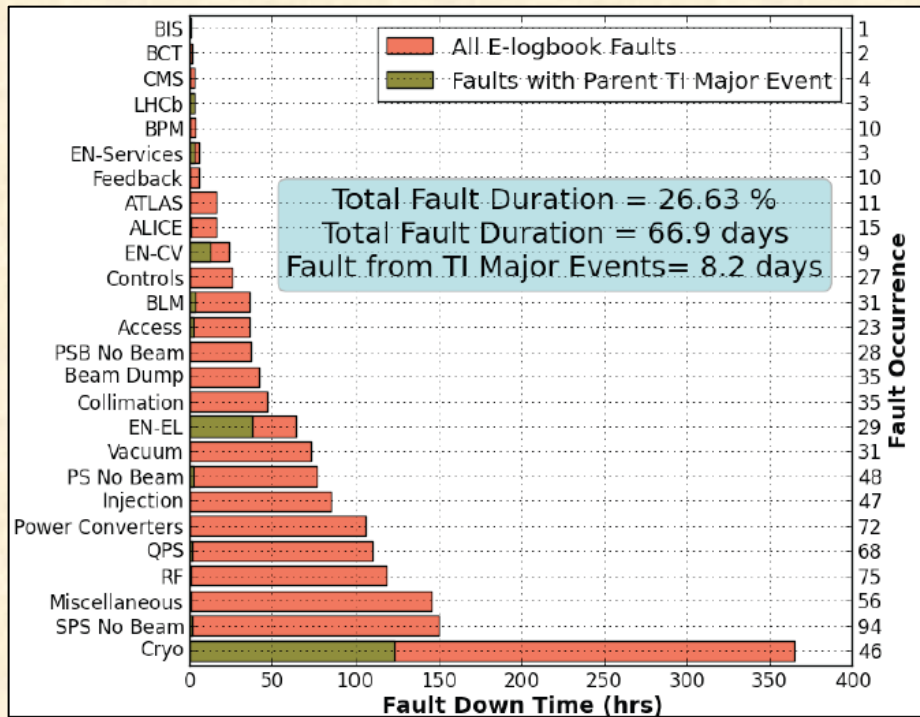

Cryogenics availability in 2012: 93.7%

some issues in 2011-12 operation

Beam induced heating

- Local non-conformities (design, installation)
 - injection protection devices
 - sync. Light mirrors
 - vacuum assemblies

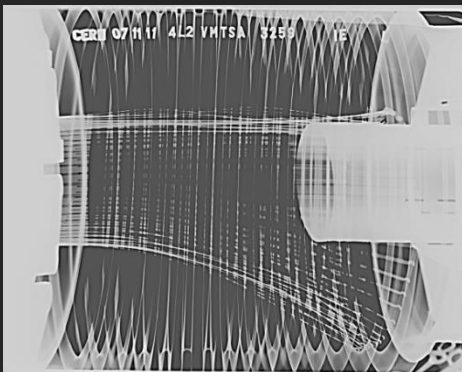

UFOs

- 20 dumps in 2012
- time scale 50-200 μs
- conditioning observed
- worry about 6.5 TeV and 25 ns spacing

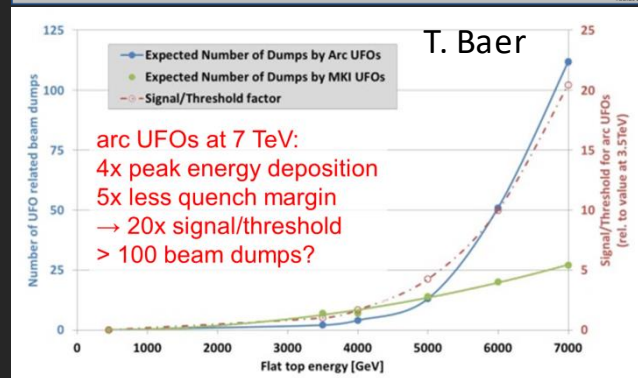
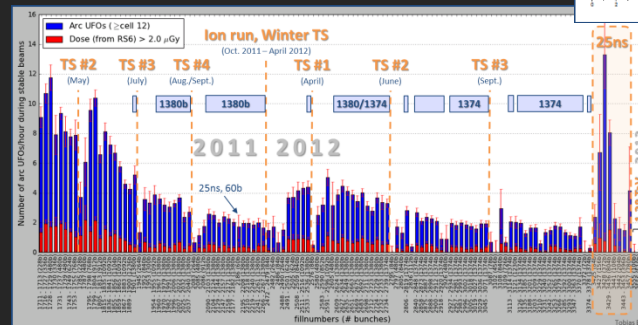
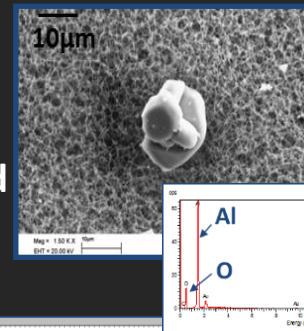

Radiation to electronics

- concerted program of mitigation measures (shielding, relocation...)
- premature dump rate down from 12/fb⁻¹ in 2011 to 3/fb⁻¹ in 2012

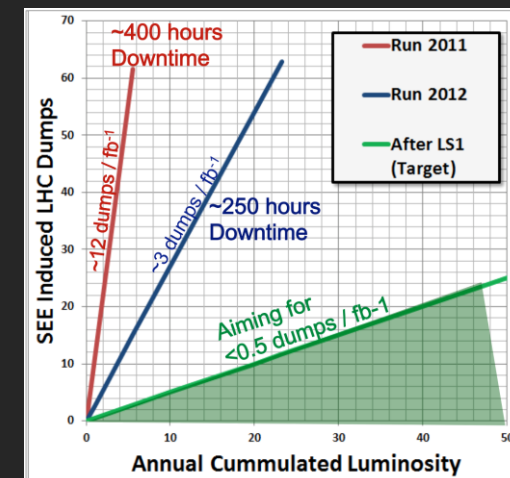

another issue in 2011-12 operation

Electron cloud

- beam induced multipactoring process, depending on secondary emission yield
- LHC strategy based on surface conditioning (scrubbing runs)
- worry about 25 ns (more conditioning needed) and 6.5 TeV (photoelectrons)

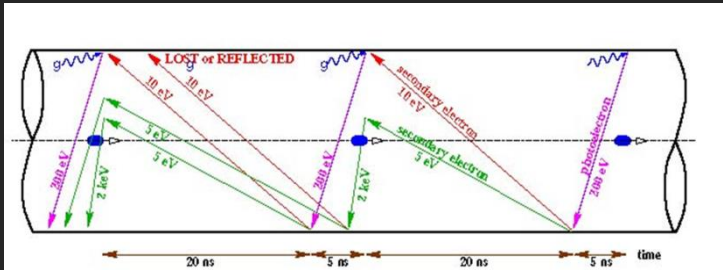

25-ns scrubbing in 2011 – decrease of SEY

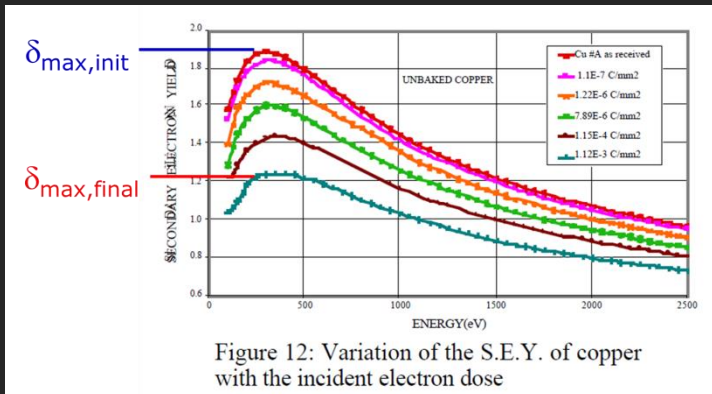
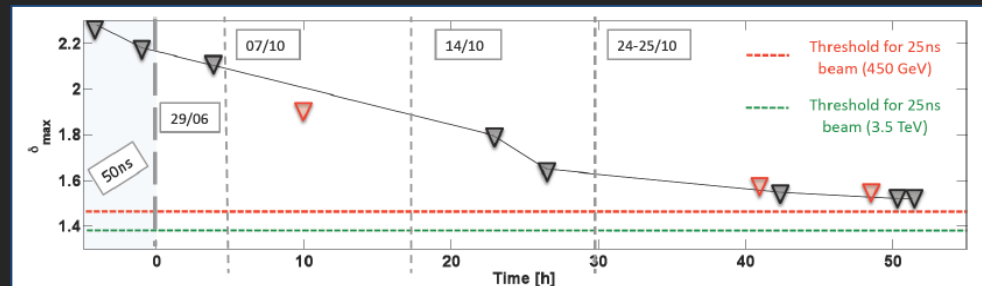
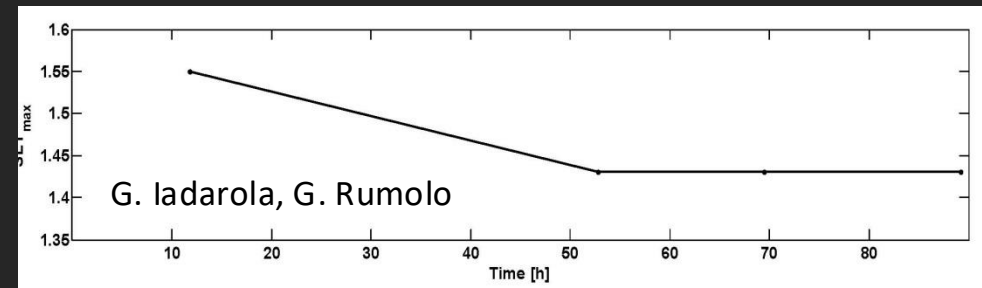

Figure 12: Variation of the S.E.Y. of copper with the incident electron dose

25-ns scrubbing in 2012 – conditioning stop?



Electron cloud effect

- Radiation from a bunch can extract electrons (and ions) from the beam pipe and from residual gas in the vacuum.
- These electrons fall back and get re-absorbed with a certain time constant.
- However if the bunch frequency is too high these electrons (and ions) will accumulate in the beam pipe and shield the beam from the magnetic elements.
- Special coatings, beam pipe geometries and bunch repetition patterns can mitigate this problem to some extent.
- This is one of the main limitations to increasing the

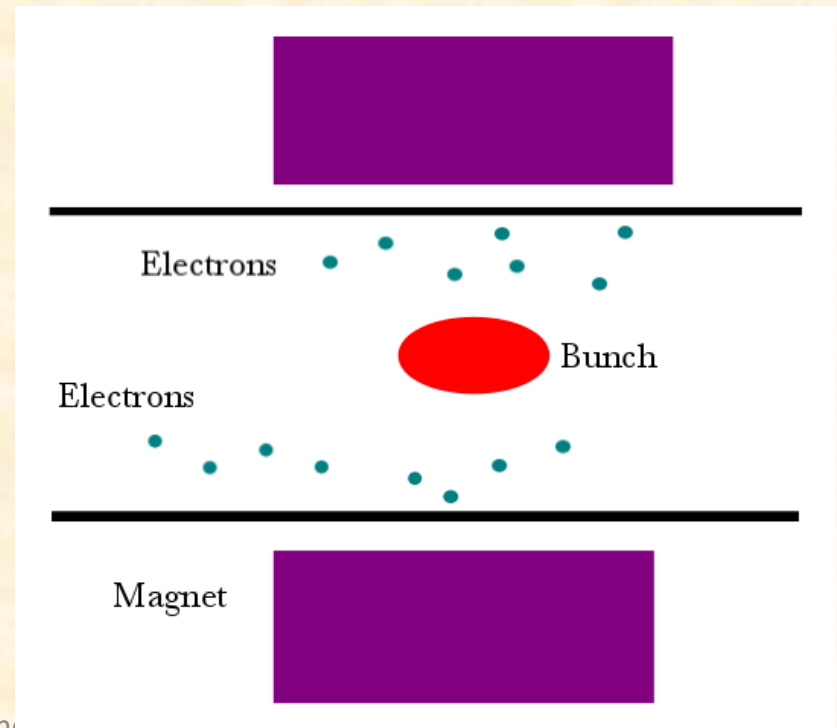
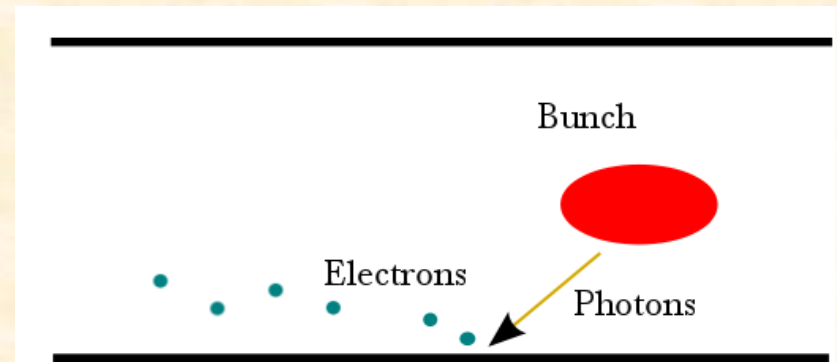

2008 “incident”

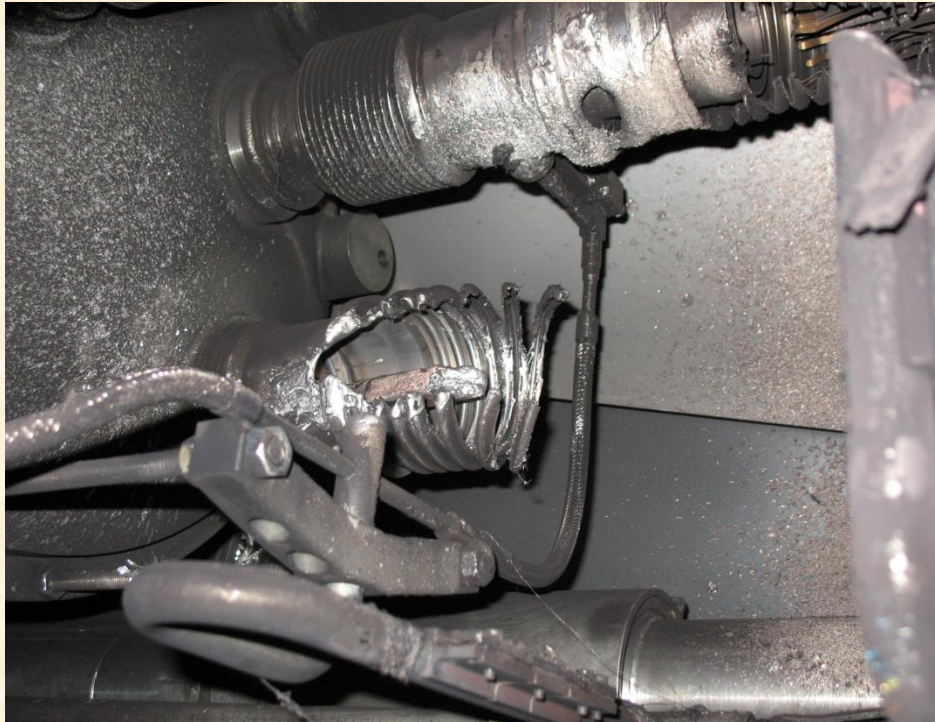

A faulty bus-bar (SC splice) in a magnet interconnect failed, leading to an electric arc which dissipated some 275 MJ

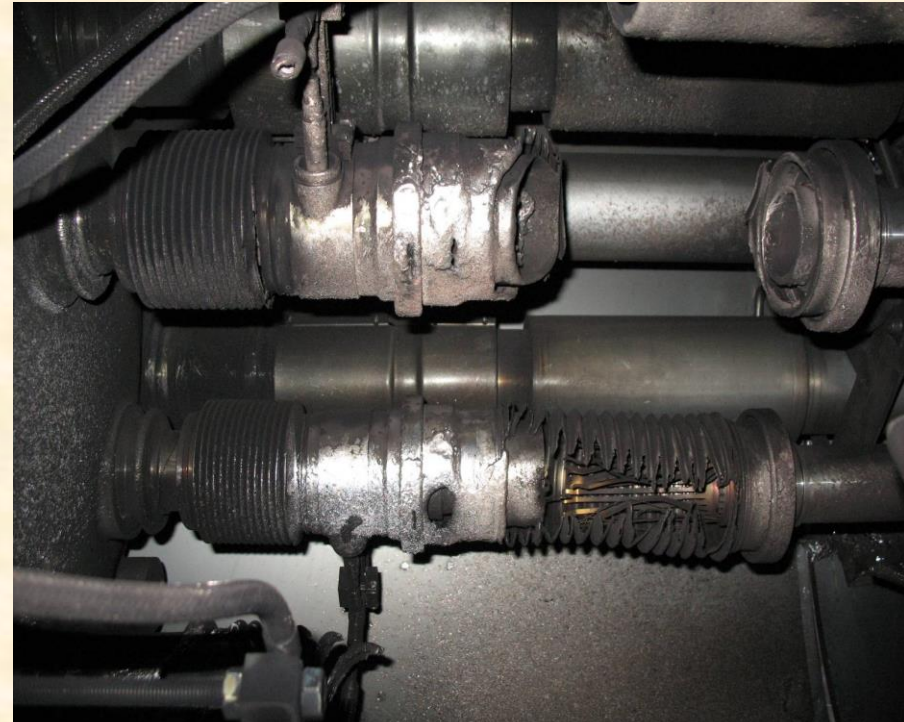

This burnt through beam vacuum and cryogenic lines, rapidly releasing ~2 tons of liquid helium into the vacuum enclosure



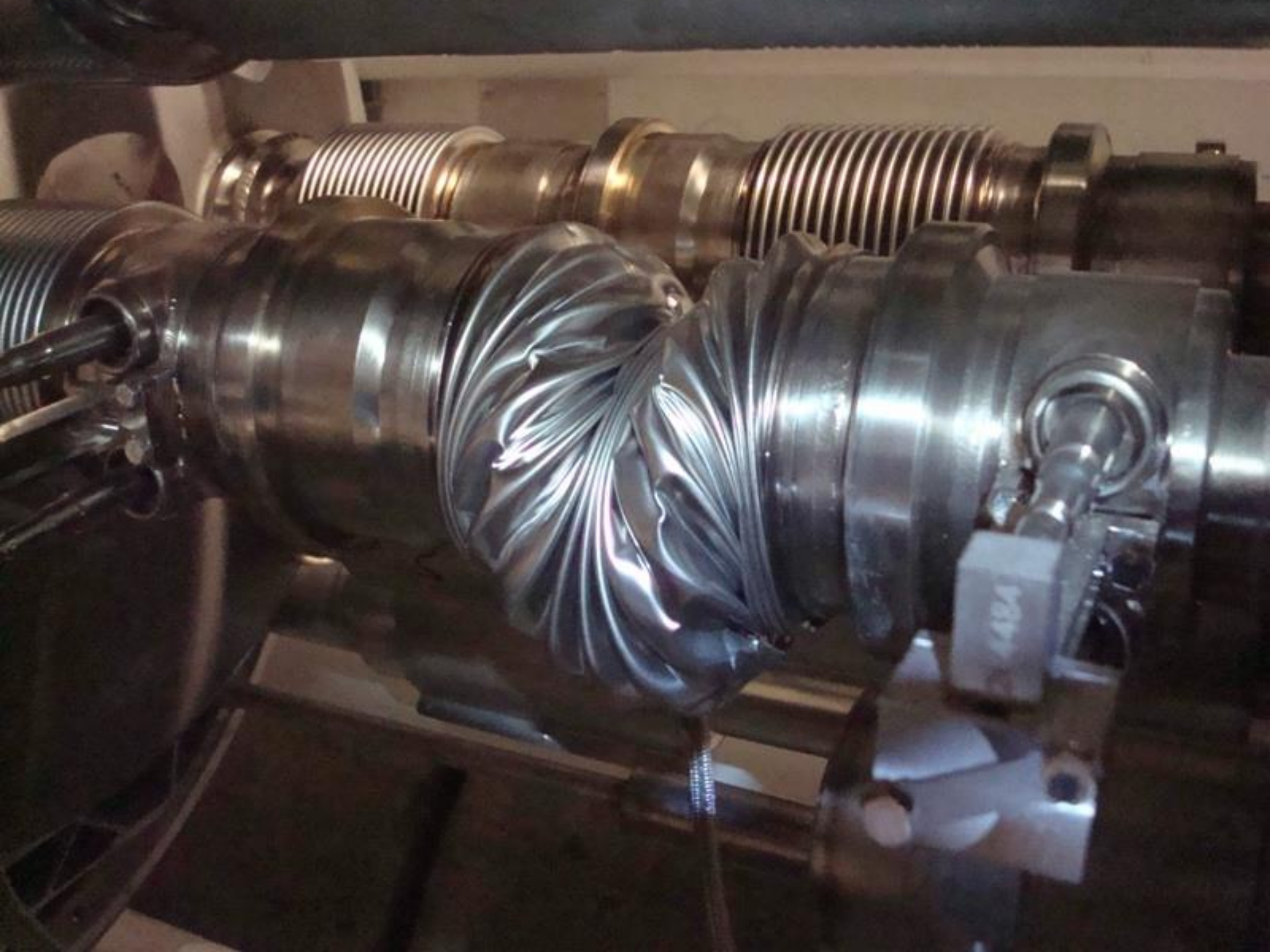



The main 2013-14 LHC consolidations

1695 Openings and final reclosures of the interconnections

Complete reconstruction of 1500 of these splices

Consolidation of the 10170 13kA splices, installing 27 000 shunts

Installation of 5000 consolidated electrical insulation systems

300 000 electrical resistance measurements

10170 orbital welding of stainless steel lines

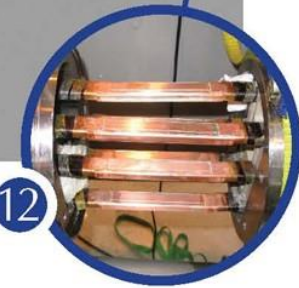
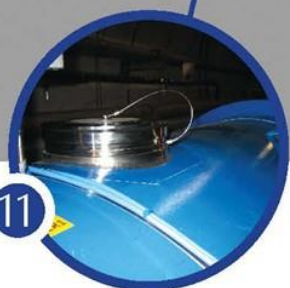
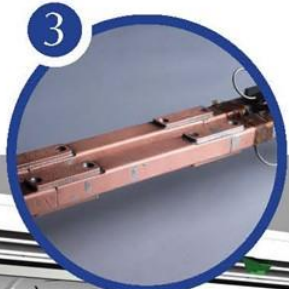

18 000 electrical Quality Assurance tests

10170 leak tightness tests

4 quadrupole magnets to be replaced

15 dipole magnets to be replaced

Installation of 612 pressure relief devices to bring the total to 1344

Consolidation of the 13 kA circuits in the 16 main electrical feed-boxes

2015 – post LS1

- energy: **6.5 TeV** (magnet retraining)
- bunch spacing: **25 ns**
 - pile-up considerations
- injectors potentially able to offer nominal intensity with even lower emittance

BCMS = Batch Compression and Merging and Splitting

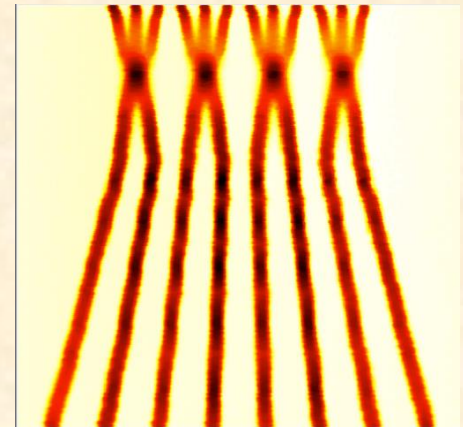

	Number of bunches	Ib LHC FT[1e11]	Emit LHC [um]	Peak Lumi [cm ⁻² s ⁻¹]	~Pile-up	Int. Lumi per year [fb ⁻¹]
25 ns low emit	2520	1.15	1.9	1.7e34	52	~45

**expected maximum luminosity
from inner triplet heat load
(collisions debris) $1.7 \times 10^{34} \text{ cm}^{-2} \text{ s}^{-1} \pm 20\%$**

Linac4 (160 MeV H^- instead of 50-MeV p)



Linac4 could double the beam brightness injected into the booster, but there may be other bottlenecks downstream (e.g. PS injection)

What Next for CERN? HiLumi-LHC (HL-LHC)

The High-Luminosity LHC

- major “upgrade” of the LHC, starting operations ~2030 and running until 2041
- based on cutting-edge Nb₃Sn technology that didn't exist when the LHC was built

With ~10 times increased luminosity compared to the LHC

- in many ways, we are just at the start of the LHC/HL-LHC journey

Meanwhile the detectors and triggers will become ever more capable

- the upgrades of ATLAS and CMS are central to the HL-LHC programme

And never forget the people

- Brilliant young researchers, aided by AI tools, will give ever greater power

The HL-LHC is an incredible scientific opportunity
- a lot more data, even better detectors, new techniques
- **real discovery potential!**



HL-LHC – modifications

IR upgrade

(detectors, low- β quad's, crab cavities, a few high-field dipoles, etc)

~2022

SPS enhancements

(anti e-cloud coating?, RF, impedance), 2012-2022

Booster energy upgrade

1.4 \rightarrow 2 GeV, ~2018

Linac4,
~2015

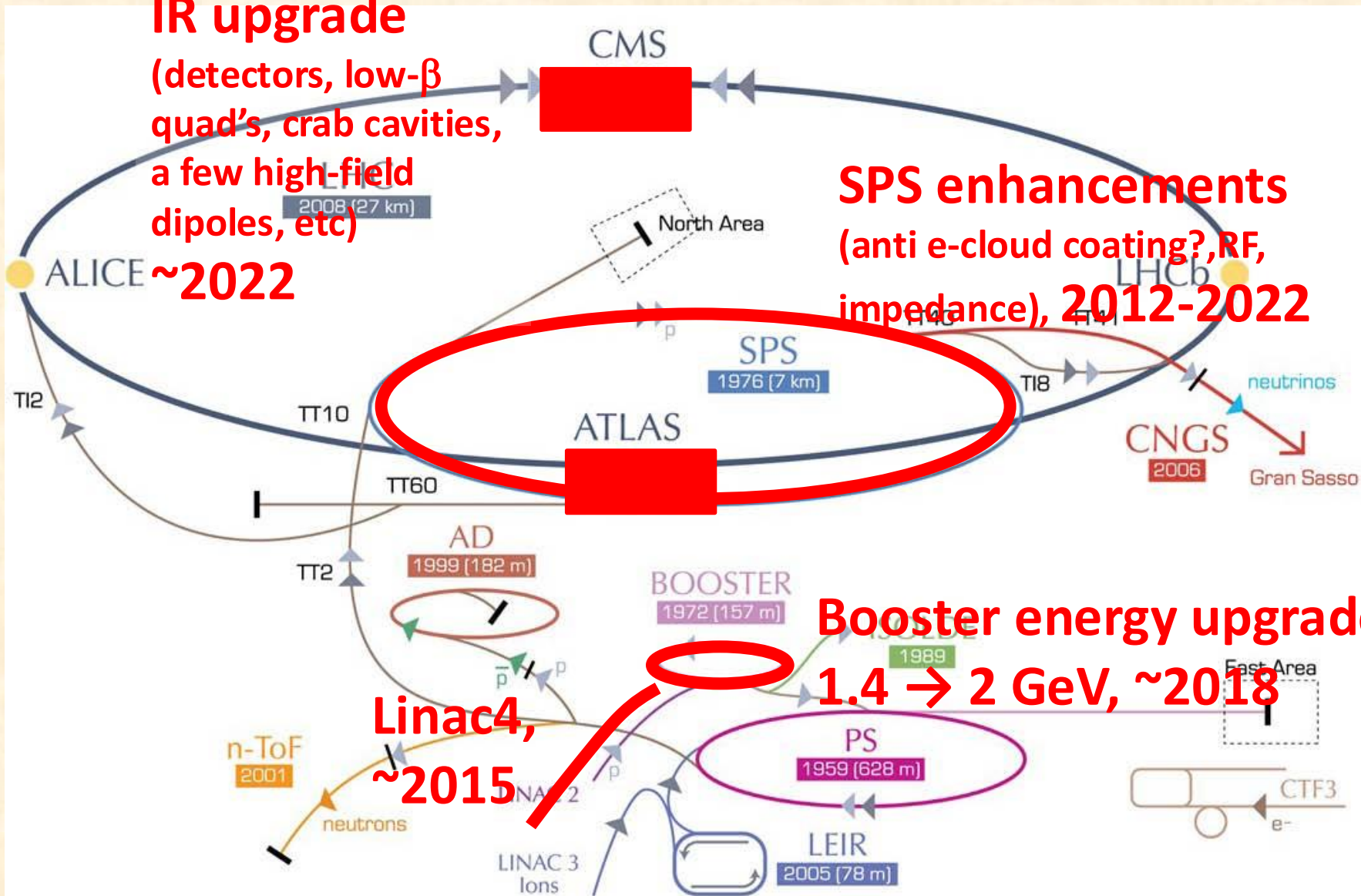

It is also a major international collaboration

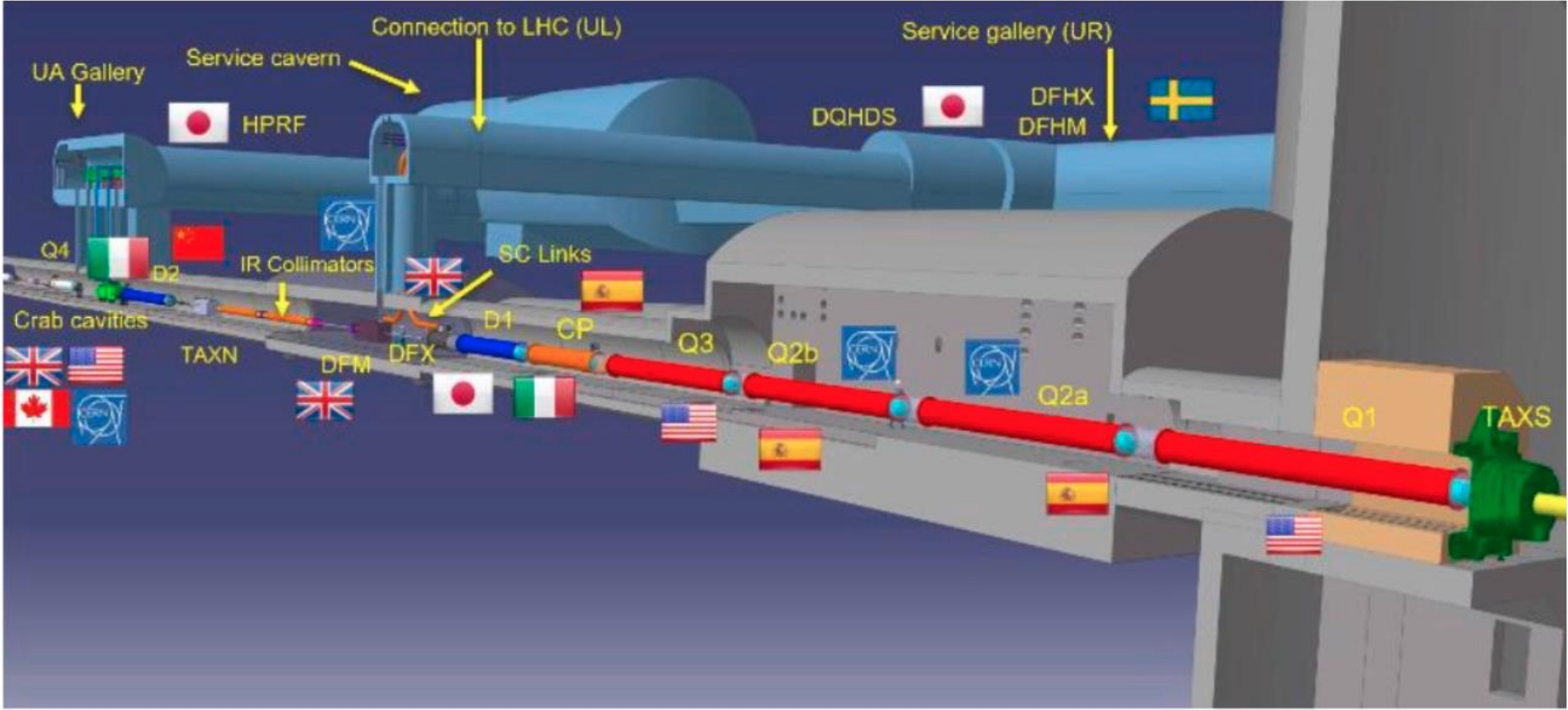

(HL-)LHC Time Line

Shut down for interconnects to overcome energy limitation (LHC incident of Sept. 2008) and R2E

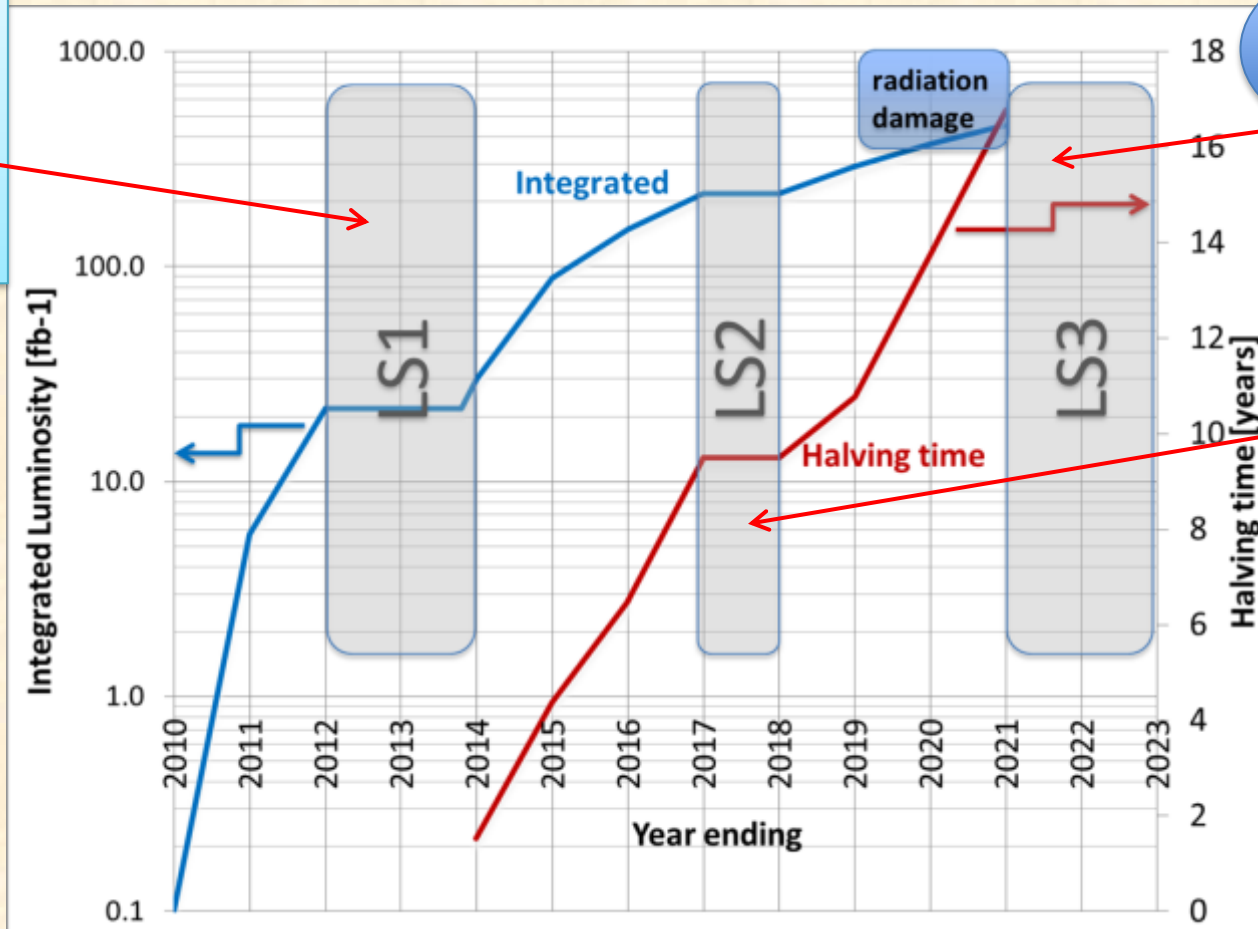

Full upgrade

Shut down to overcome beam intensity limitation (Injectors, collimation and more...)

two reasons for HL-LHC: performance & consolidation
In fact LS3 started in 2026...

Long shutdown 3

Long Shutdown 3 is coming...

We are here → + 4 years

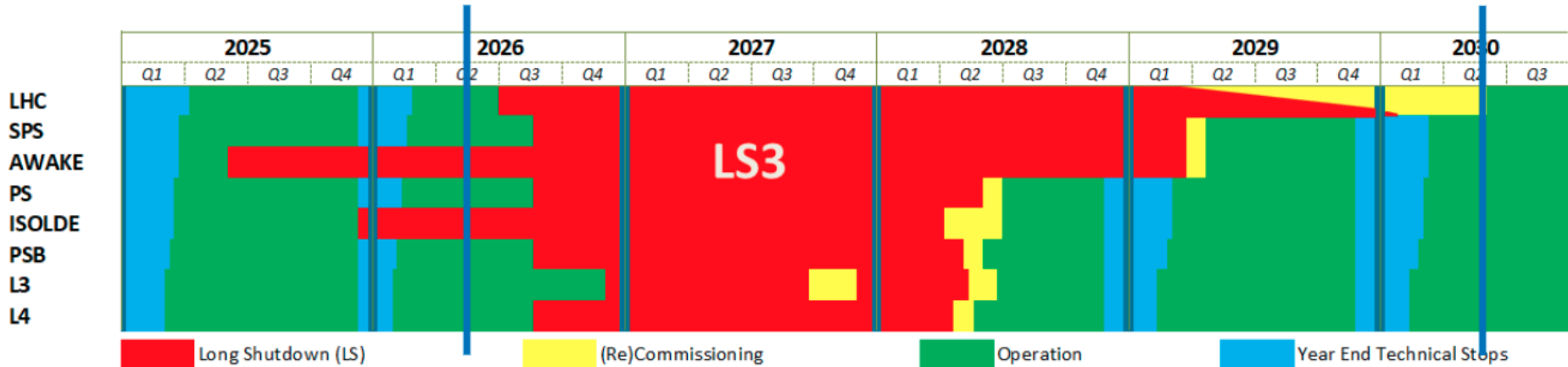

LS 3 start

- AWAKE: 02.06.2025
- ISOLDE: 08.12.2025
- LHC: 29.06.2026
- Injectors: 31.08.2026
- L3: 30.11.2026

Inj. Operation restart

- L4 : May 2028
 - PSB : May 2028
 - PS : July 2028 (*)
 - SPS : April/May 2029 (*)
- (*) To be optimised

LHC restart

- 1st sectors cooldown : Early 2029
- Final HW Com (P1&5) : January 2030
- Caverns closure : Mid-May 2030
- Beam vac valves op : End-May 2030

in LHC: 1.2 km of new equipment ...

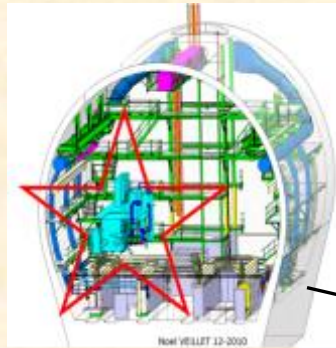

6.5 kW@4.5K
cryoplant

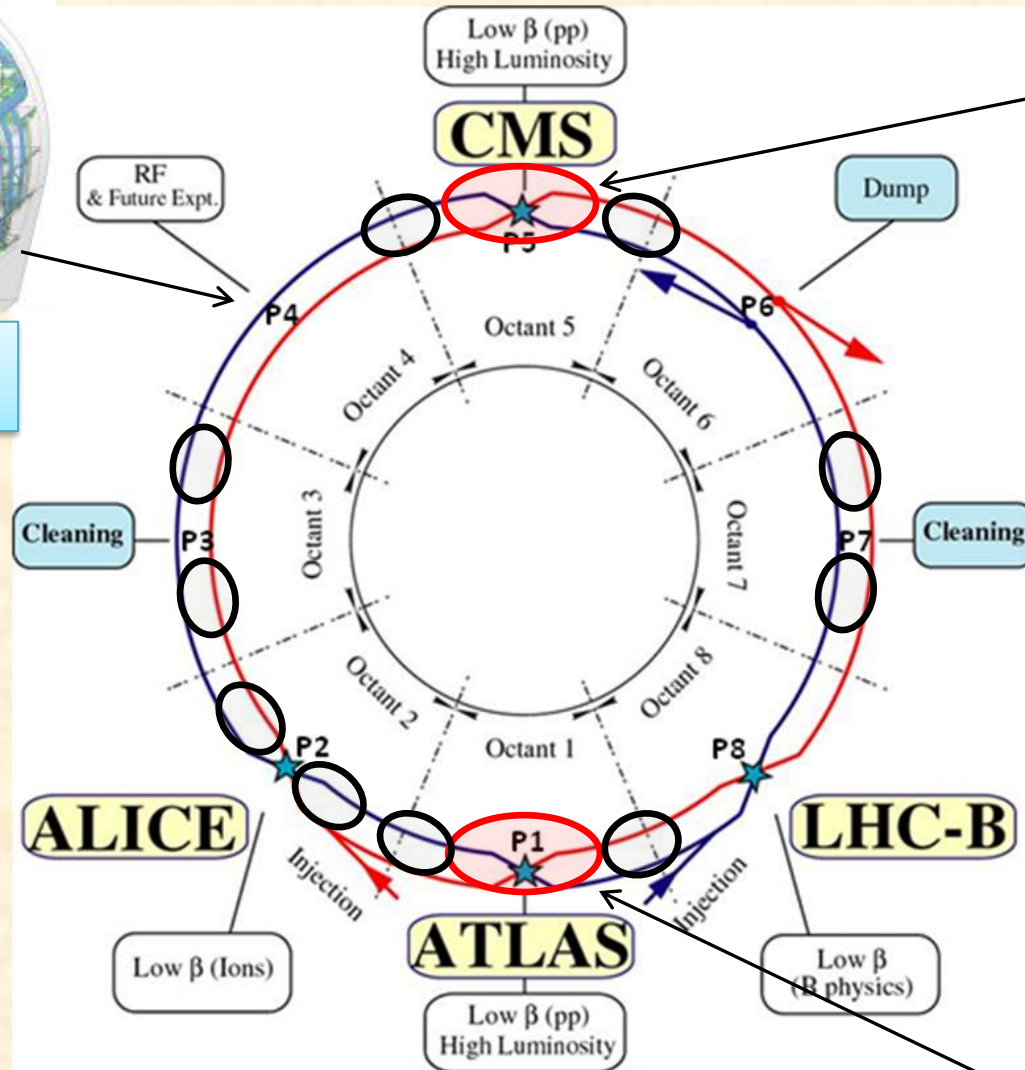

2 x 18 kW @4.5K
cryoplants for IRs



HL-LHC Official Beam Parameters

Parameter	nominal	25ns	50ns	
N	1.15E+11	2.2E+11	3.5E+11	6.2 10¹⁴ and 4.9 10¹⁴ p/beam
n _b	2808	2808	1404	
beam current [A]	0.58	1.12	0.89	
x-ing angle [μrad]	300	590	590	
beam separation [σ]	10	12.5	11.4	
β* [m]	0.55	0.15	0.15	
ε _n [μm]	3.75	2.5	3.0	
ε _L [eVs]	2.51	2.5	2.5	
energy spread	1.20E-04	1.20E-04	1.20E-04	
bunch length [m]	7.50E-02	7.50E-02	7.50E-02	
IBS horizontal [h]	106	20.0	20.7	
IBS longitudinal [h]	60	15.8	13.2	
Piwinski parameter	0.68	3.1	2.9	
geom. reduction	0.83	0.35	0.33	
beam-beam / IP	3.10E-03	3.9E-03	5.0E-03	(Leveled to 5 10³⁴ cm⁻² s⁻¹ and 2.5 10³⁴ cm⁻² s⁻¹)
Peak Luminosity	1 10 ³⁴	7.4 10³⁴	8.5 10³⁴	
Virtual Luminosity	1.2 10 ³⁴	21 10³⁴	26 10³⁴	
Events / crossing (peak & leveled L)	27	210	475	140 140

luminosity leveling at the HL-LHC

example: maximum pile up 140
($\sigma_{\text{inel}} \sim 85$ mbarn)

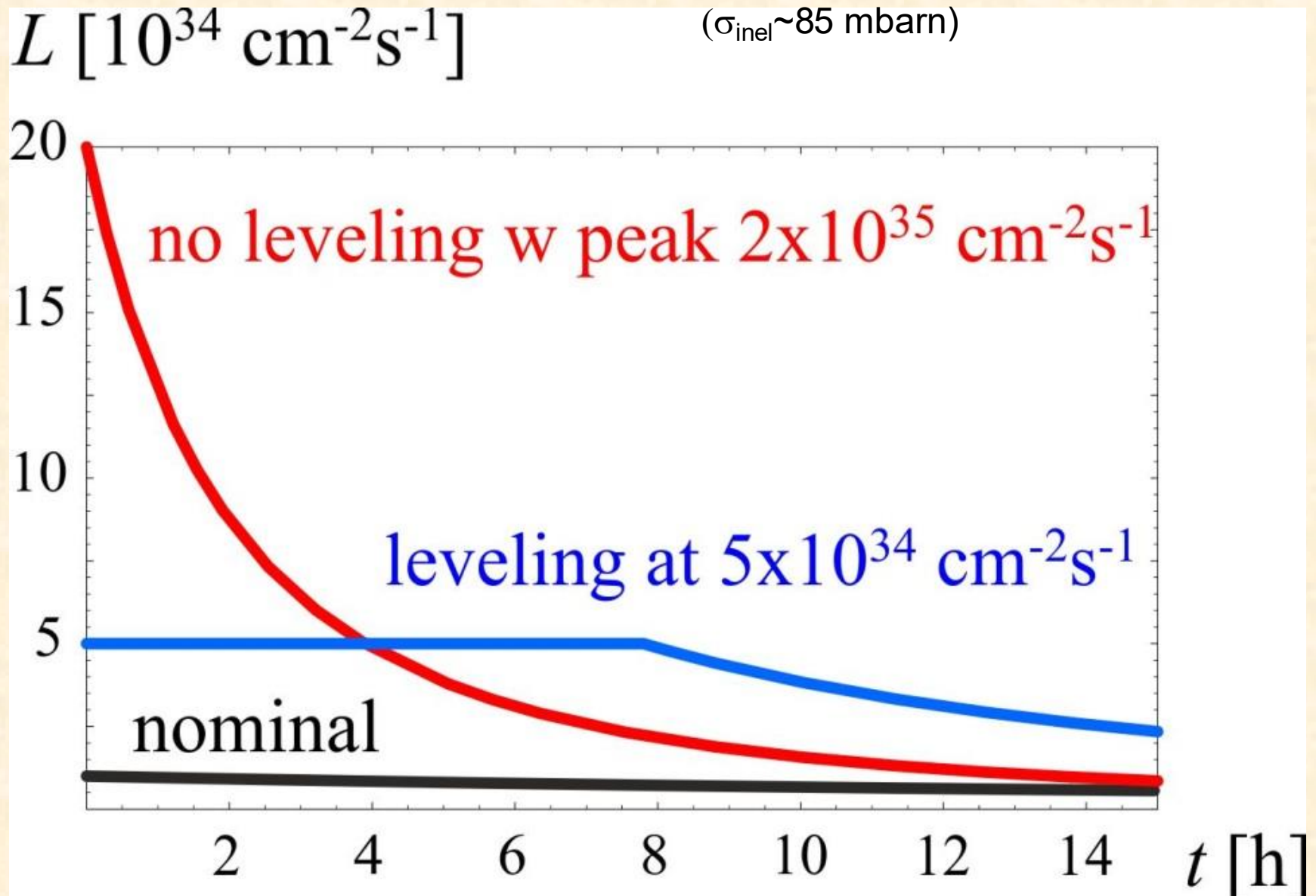

luminosity leveling at the HL-LHC

example: maximum pile up 140

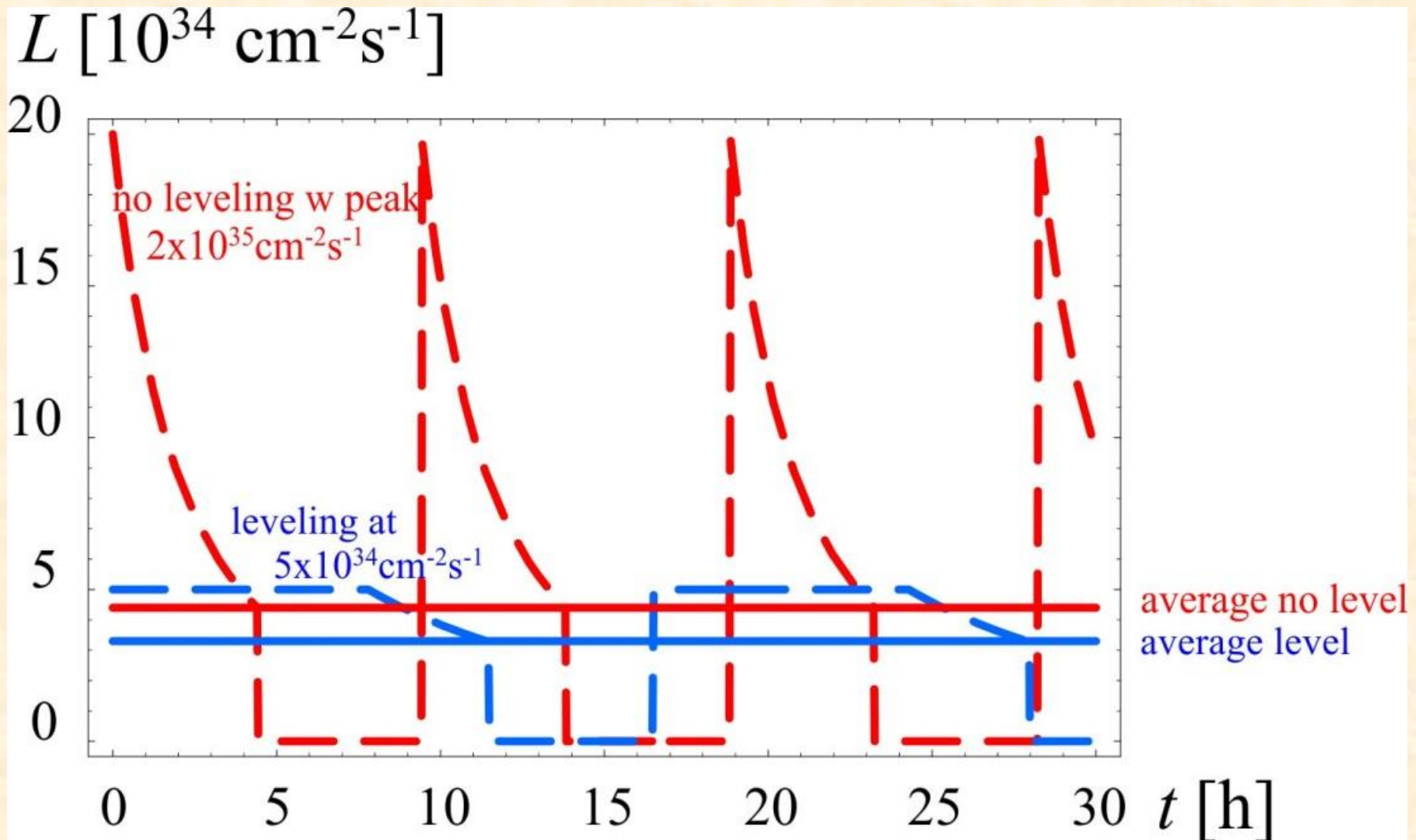

luminosity & integrated luminosity during 30 h at the HL-LHC

example: maximum pile up 140

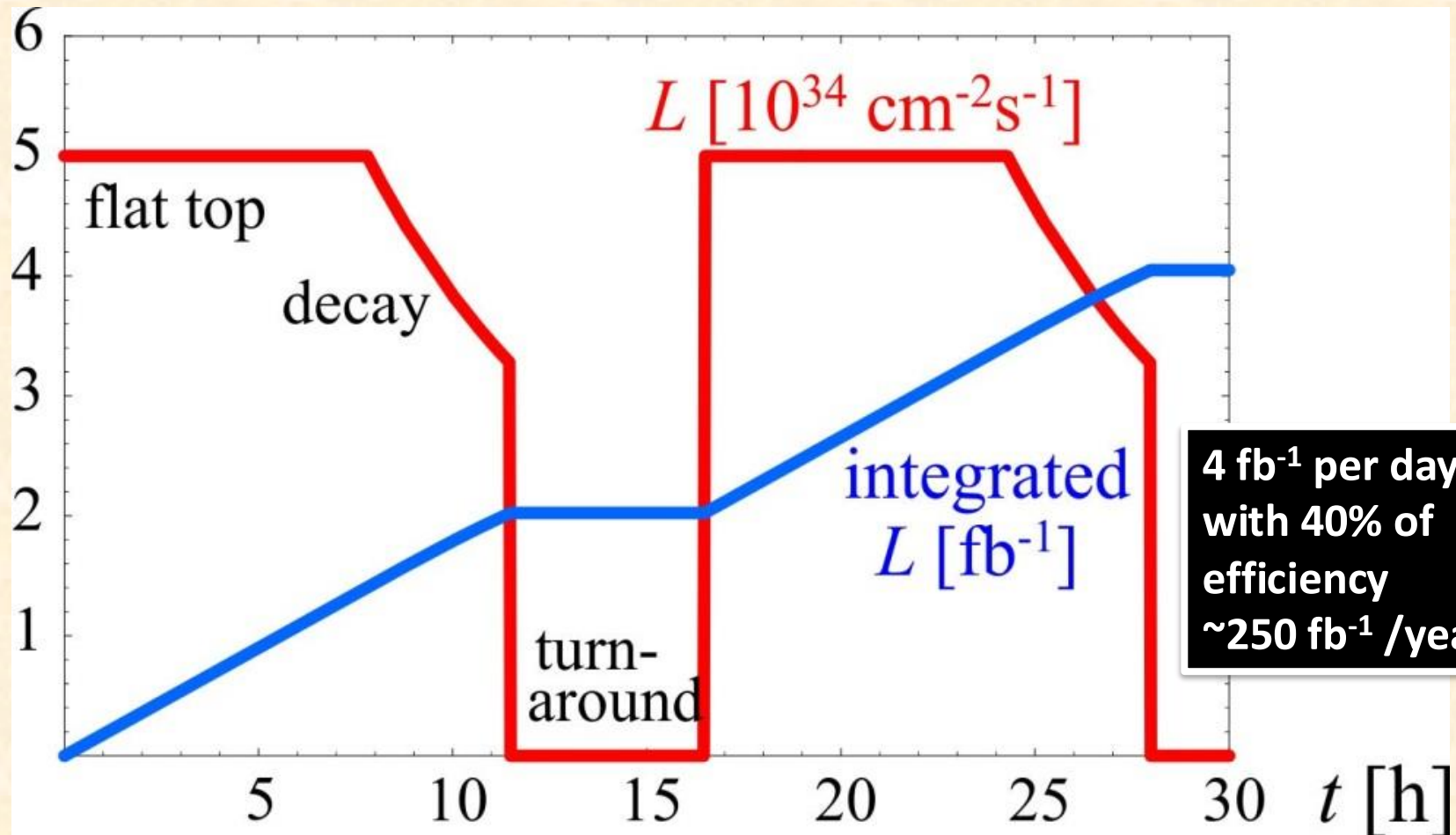

final goal : 3000 fb⁻¹ by 2030's...

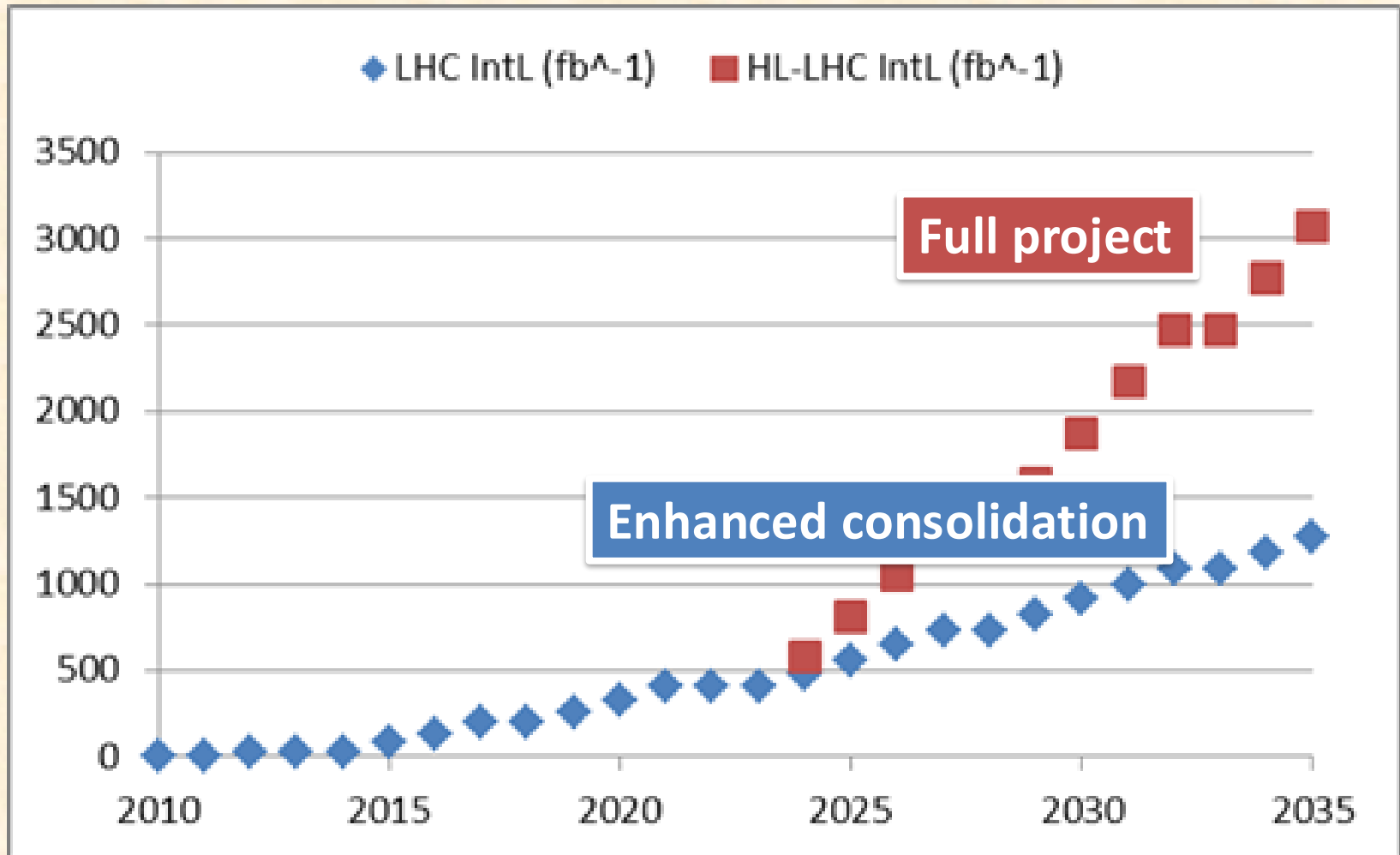

HL LHC

NEW TECHNOLOGIES FOR THE HIGH-LUMINOSITY LHC

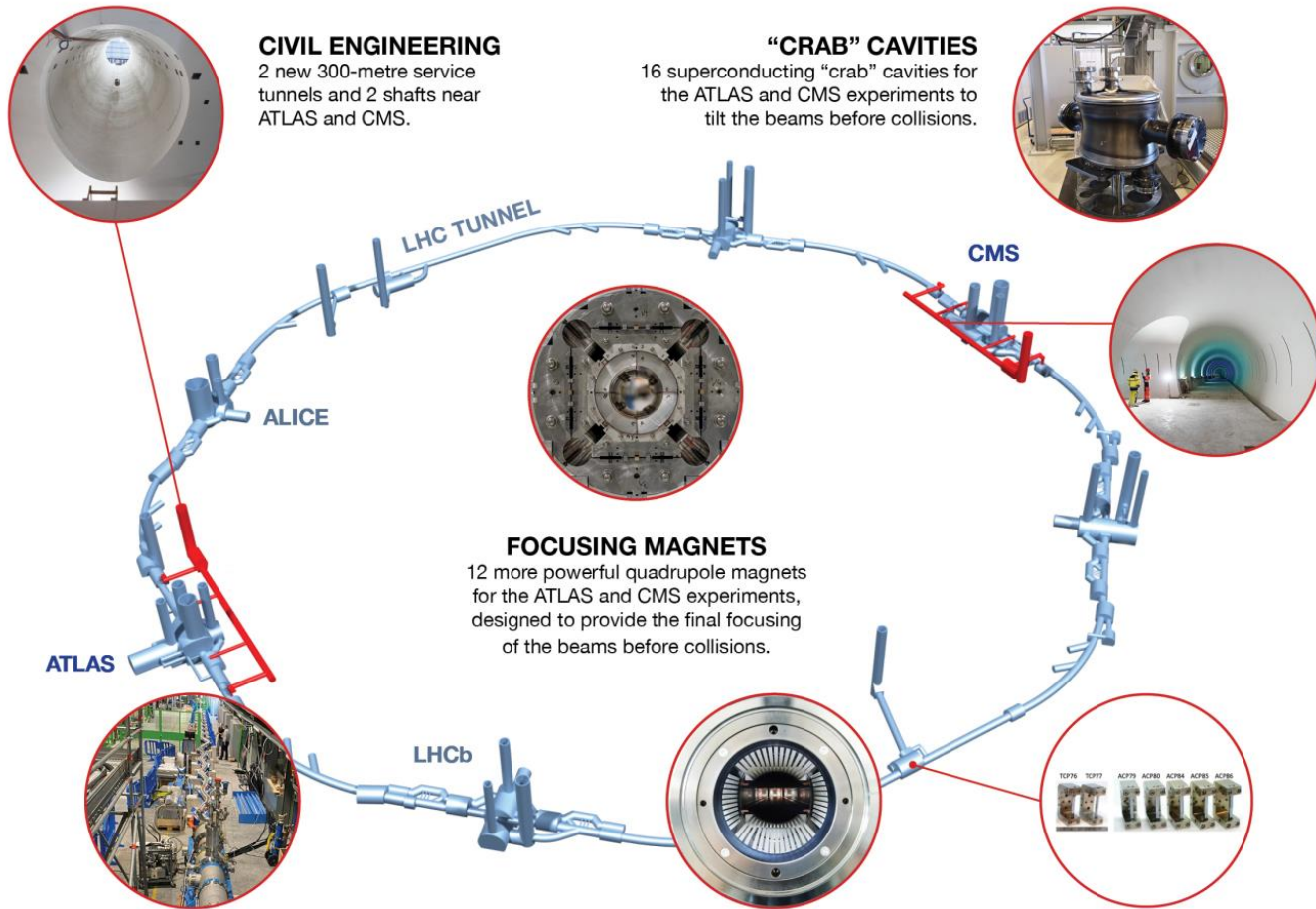

CIVIL ENGINEERING

2 new 300-metre service tunnels and 2 shafts near ATLAS and CMS.

“CRAB” CAVITIES

16 superconducting “crab” cavities for the ATLAS and CMS experiments to tilt the beams before collisions.

FOCUSING MAGNETS

12 more powerful quadrupole magnets for the ATLAS and CMS experiments, designed to provide the final focusing of the beams before collisions.

SUPERCONDUCTING LINKS

Electrical transmission lines based on a high-temperature superconductor to carry the very high DC currents to the magnets from the powering systems installed in the new service tunnels near ATLAS and CMS.

COLLIMATORS

15 to 20 additional collimators and replacement of 60 collimators with improved performance to reinforce machine protection.

CRYSTAL COLLIMATORS

New crystal collimators in the IR7 cleaning insertion to improve cleaning efficiency during operation with ion beams.

some HL-LHC ingredients

new final quadrupoles

- Nb_3Sn instead of $Nb-Ti$
- larger aperture allowing smaller β^*

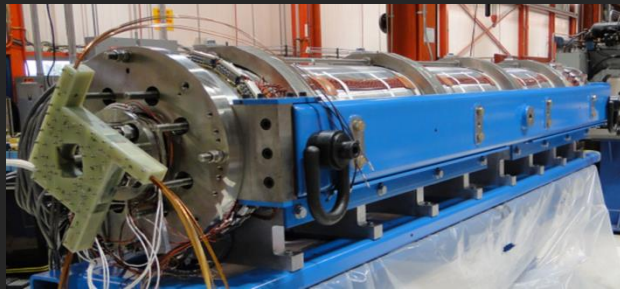

LQS03 (90 mm ap., 3.7 m long):
208 T/m@4.6 K, 210 T/m@1.9 K

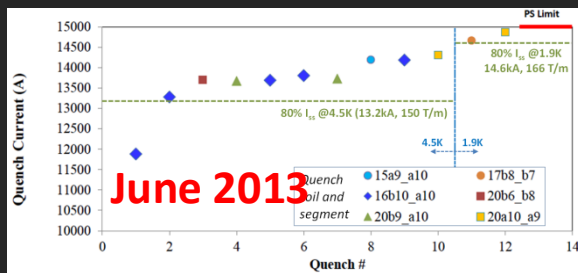

HQ02a (120 mm, 1.5 m long):
150 T/m@4.6 K, 170 T/m@1.9 K

Goal: 150 mm ap, 140 T/m

11-T dipoles for dispersion suppressors

- Nb_3Sn instead of $Nb-Ti$
- provide space for extra collimators catching off-energy protons or ions at ALICE, collimator sections, ATLAS & CMS

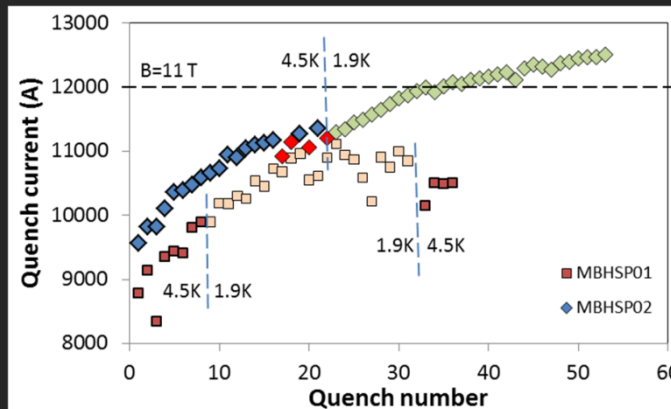

1-m model tested in April 2014,
 $B_{nom}=11$ T achieved!

Next: 2-m single bore, then 2-in-1

SC link



- move radiation sensitive power converters away from machine
- first prototype, 20 m – 20 kA, under test at CERN!



- also of interest for electrical power distribution

tests of novel MgB_2 and HTS (YBCO and BSCCO) cables

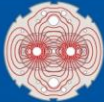

LHC / HL-LHC Plan

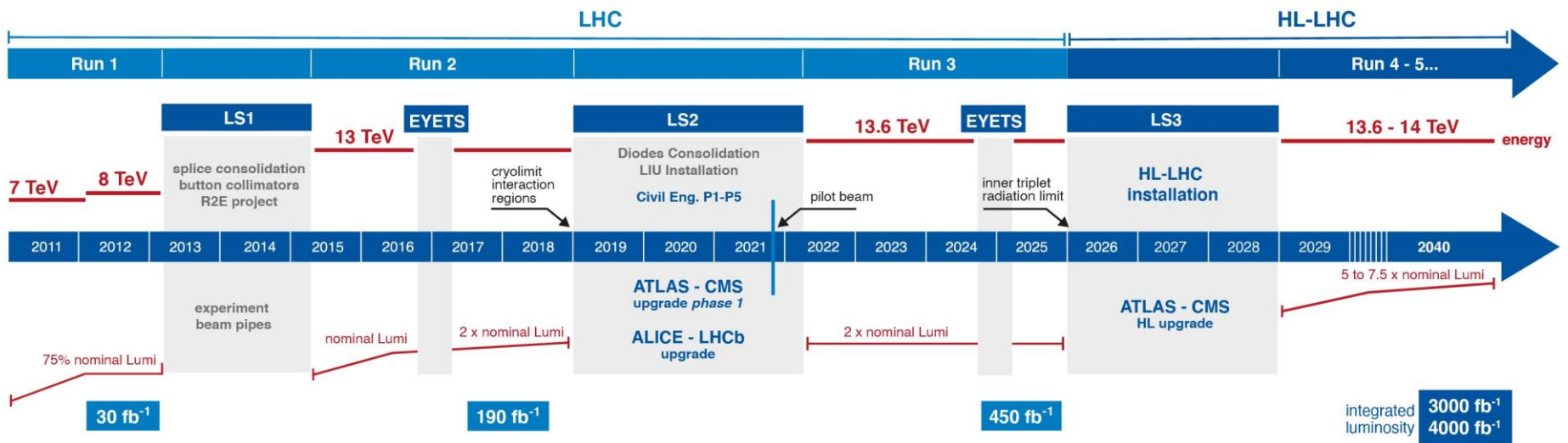

HL-LHC TECHNICAL EQUIPMENT:



HL-LHC CIVIL ENGINEERING:



HL-LHC optics

S. Fartoukh

Achromatic Telescopic Squeeze (ATS), «fully proven»
MDs ($\beta^* = 15$ cm «easy», room for $\beta^* \sim 10$ -12 cm)

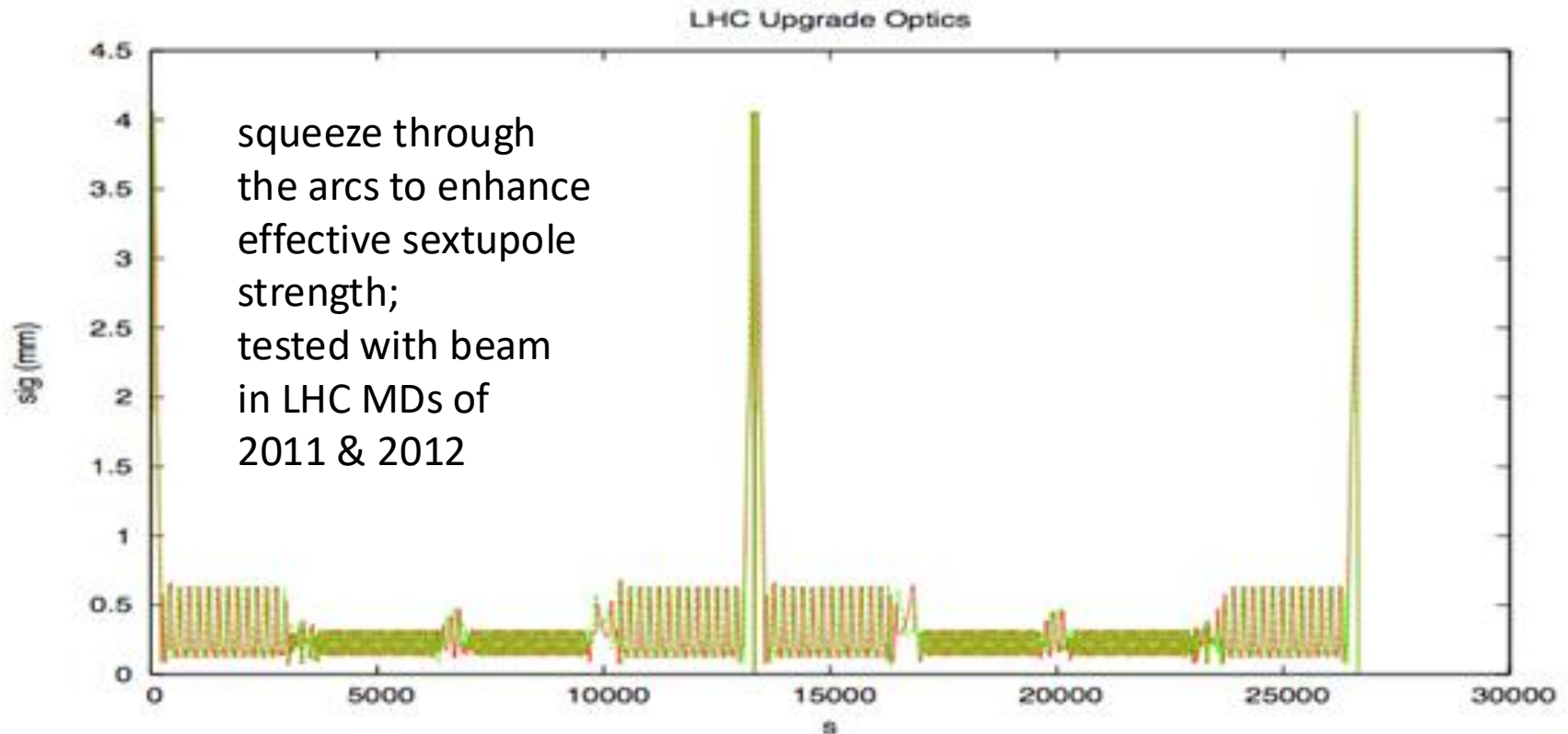

typical ATS collision optics with IR1 & IR5 squeezed down to $\beta^* = 10$ cm

schematic of crab crossing

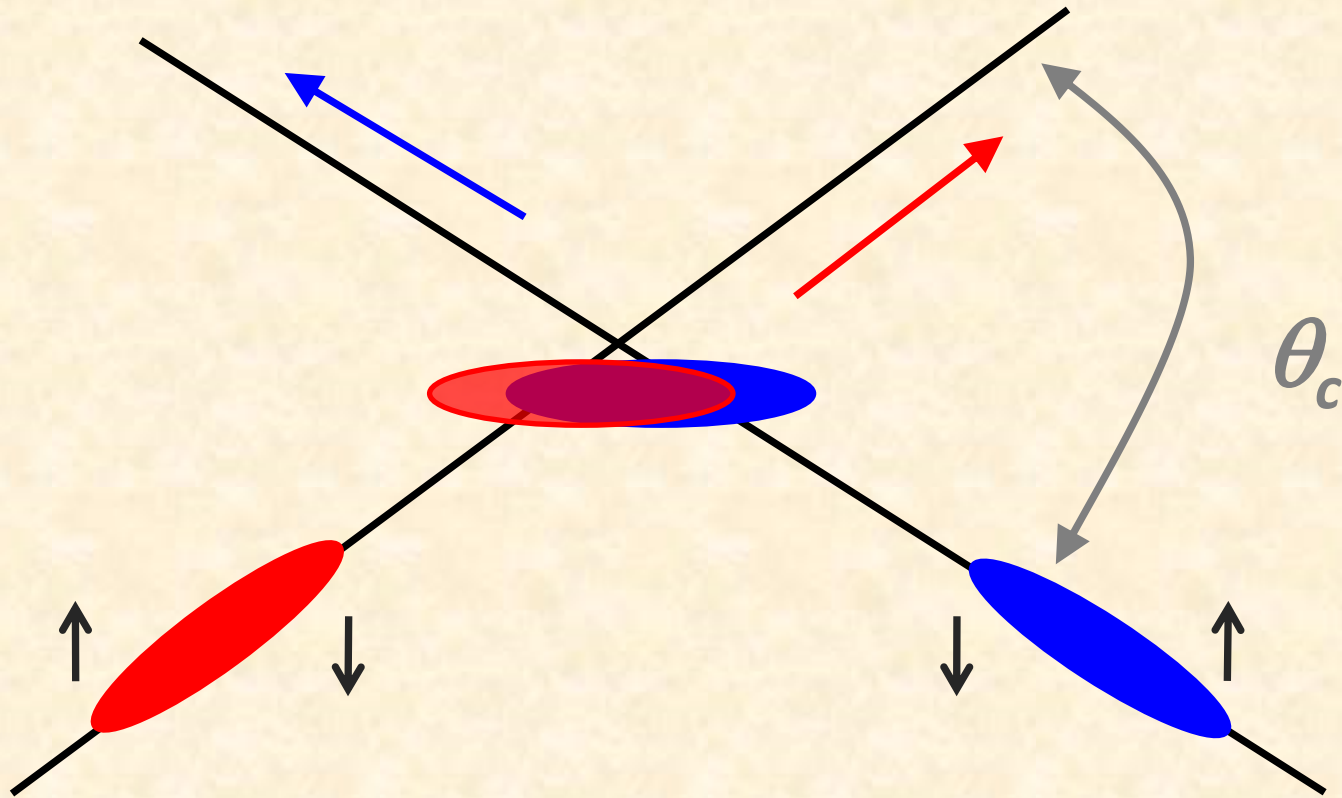

- RF crab cavity deflects head and tail in opposite direction so that collision is effectively “head on” for luminosity and tune shift
- bunch centroids still cross at an angle (easy separation)
- 1st proposed in 1988, used in operation at KEKB since 2007

until recently plan was to vary crab cavity voltage for leveling, but this would change size of luminous region & is disliked by experiments (instead leveling by β^* or offset?)

luminosity reduction due to crossing angle is more pronounced at smaller β^*

“Piwinski angle”

luminosity reduction factor

$$R_\theta = \frac{1}{\sqrt{1 + \Theta^2}}; \quad \Theta \equiv \frac{\theta_c \sigma_z}{2\sigma_x}$$

R_θ

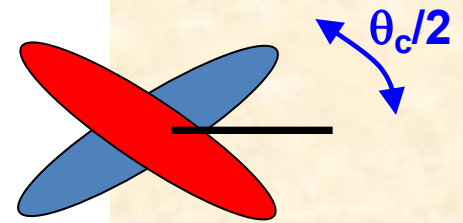
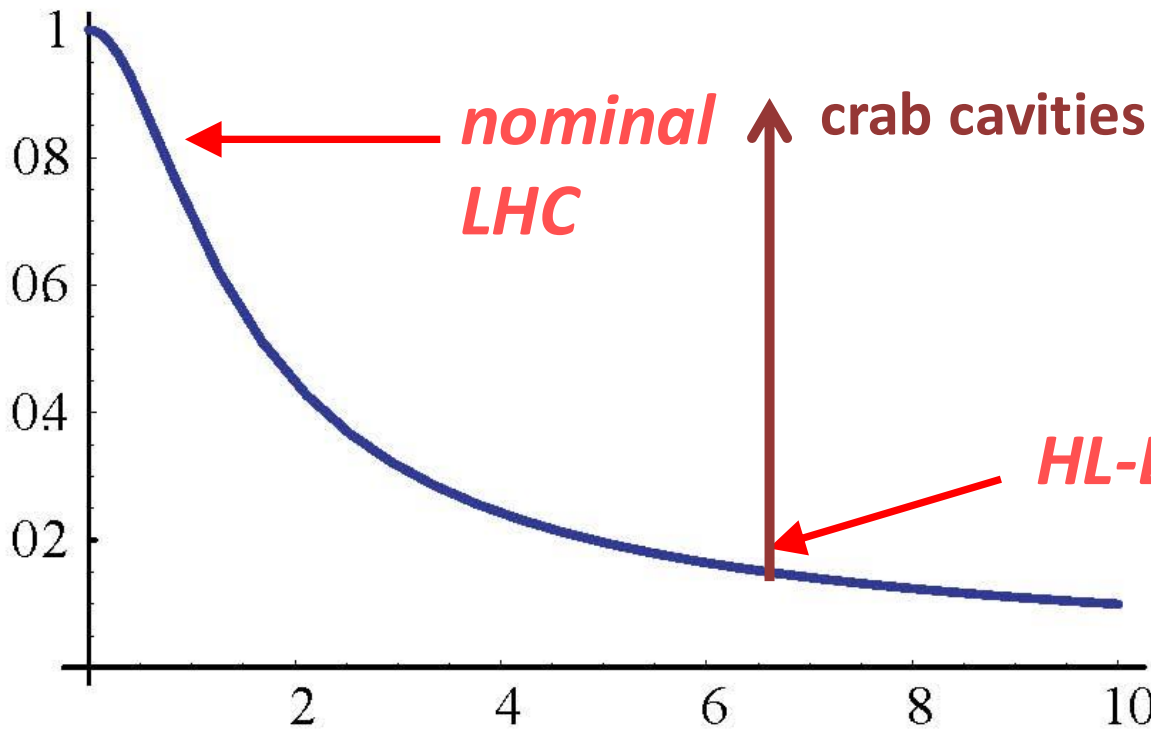

eff. beam size:

$$\sigma_{x,\text{eff}}^* \approx \sigma_x^* / R_\theta$$

$$\Theta \sim 1/\beta^*$$

HL-LHC needs compact crab cavities

only 19 cm beam separation, but long bunches

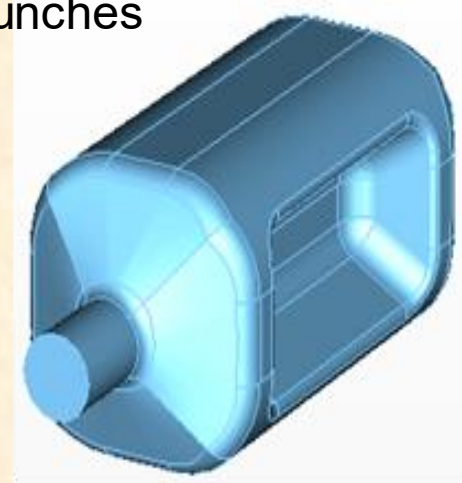
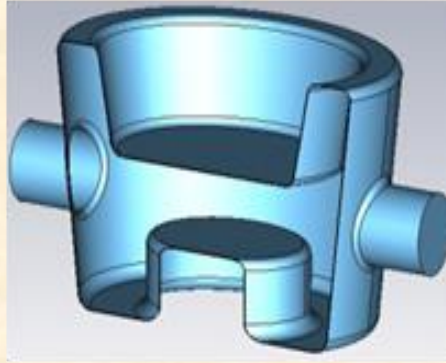
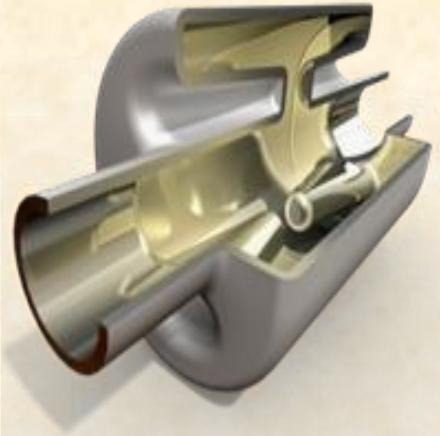

Final down-selected compact cavity designs for the LHC upgrade: 4-rod cavity design by Cockcroft I. & JLAB (left), $\lambda/4$ TEM cavity by BNL (centre), and double-ridge $\lambda/2$ TEM cavity by SLAC & ODU (right).



Prototype compact *Nb-Ti* crab cavities for the LHC: 4-rod cavity (left) and double-ridge cavity (right).

HL-LHC preliminary budget estimate

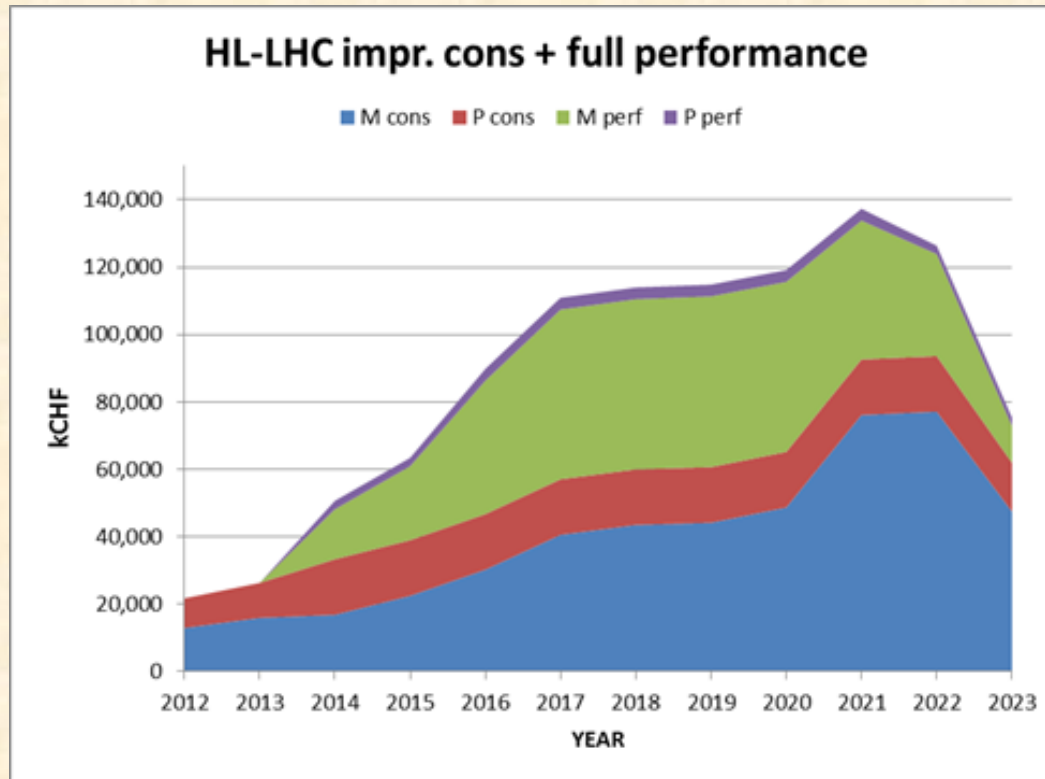

	Improving Consolidation	Full performance	Total HL-LHC
Mat. (MCHF)	476	360	836
Pers. (MCHF)	182	31	213
Pers. (FTE-y)	910	160	1070
TOT (MCHF)	658	391	1,049

(most slides courtesy of Dr Rhodri Jones)

LHC BEAM INSTRUMENTATION

Beam Profile Monitoring using Wire-Scanners

Vacuum tube

Particle beam

Secondary Particles generated by beam interactions with the wire

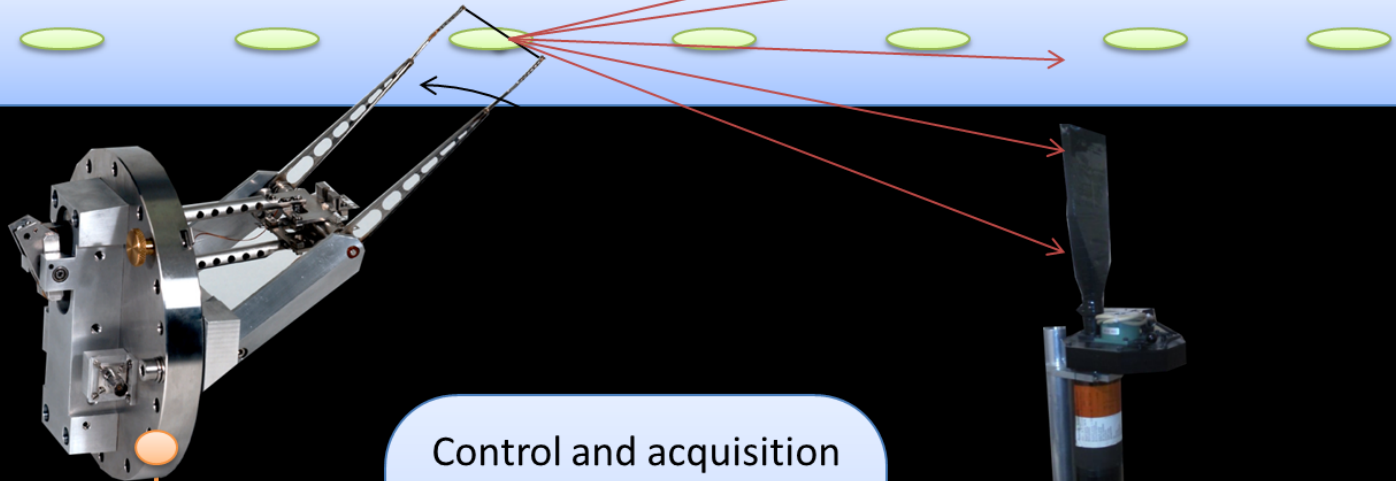

Control and acquisition Electronics

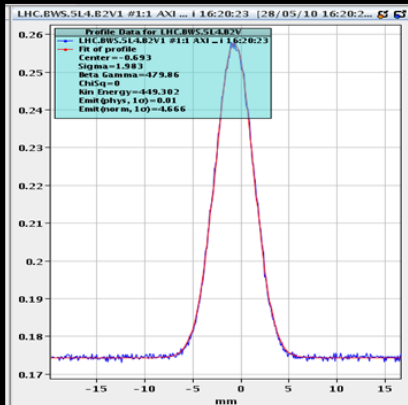

Limitation of WireScanners

- Wire Breakage – why?
 - Brittle or Plastic failure (error in motor control)
 - Melting/Sublimation (main intensity limit)
 - Due to energy deposition in wire by proton beam
- Temperature evolution depends on
 - Heat capacity, which increases with temperature!
 - Cooling
 - Radiative
 - Conductive
 - Thermionic
 - Sublimation

- Wire Choice

- 33 μm Carbon
 - Good mechanical properties
 - Sublimates at 3915K

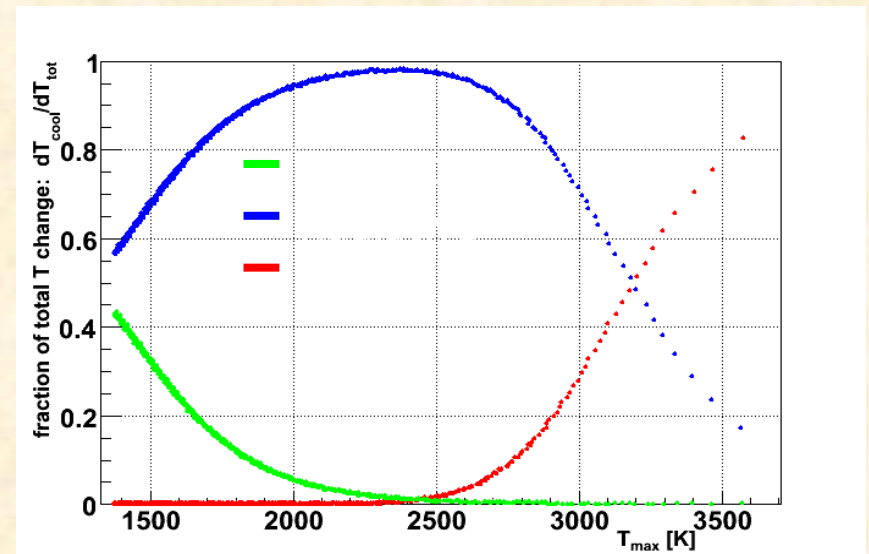

- Typical scan lasts 1 ms & total cooling time constant $\sim 10\text{-}15$ ms
 - Cooling during measurement negligible

Synchrotron Light in the LHC

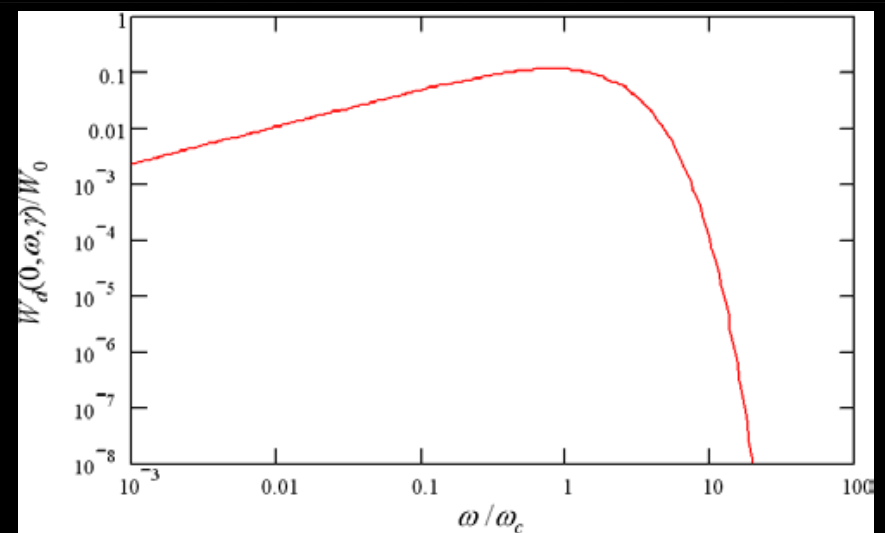
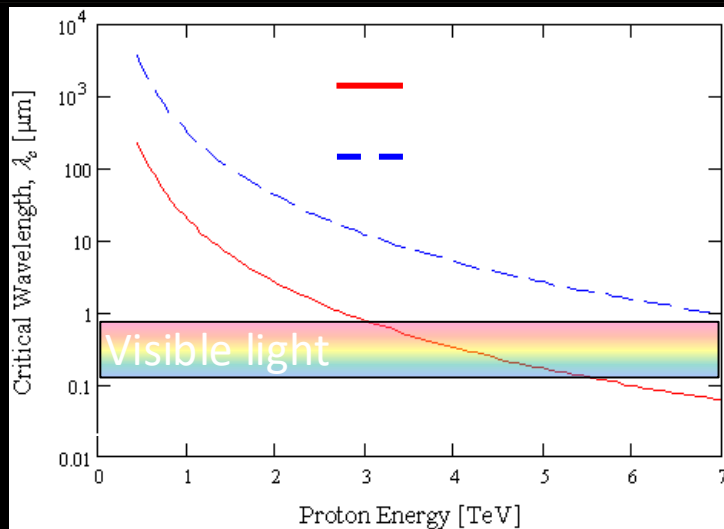
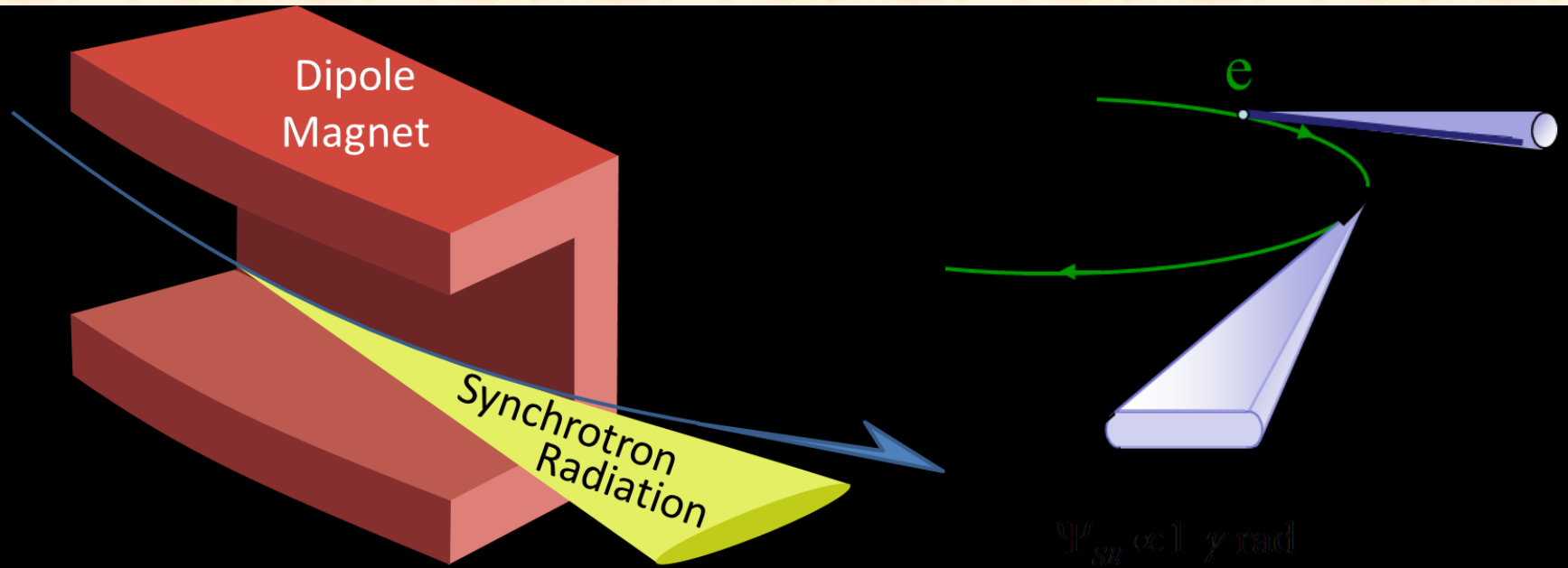

Synchrotron Light in the LHC

- At LHC injection energy
 - Visible emission from D3 dipole very low
 - Short superconducting undulator added
 - 2 periods of length 28cm with B field of 5 T

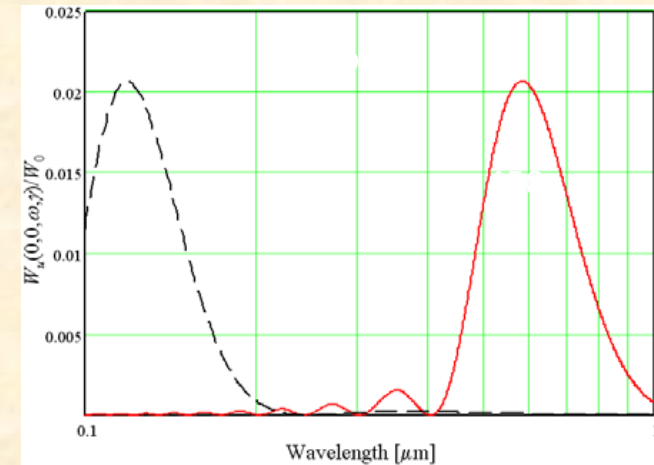
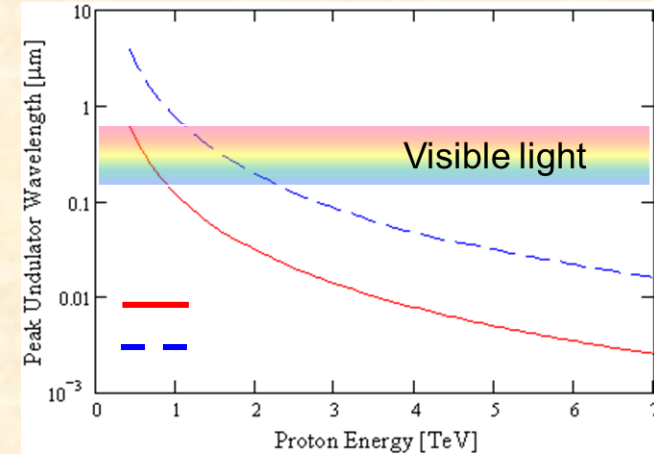
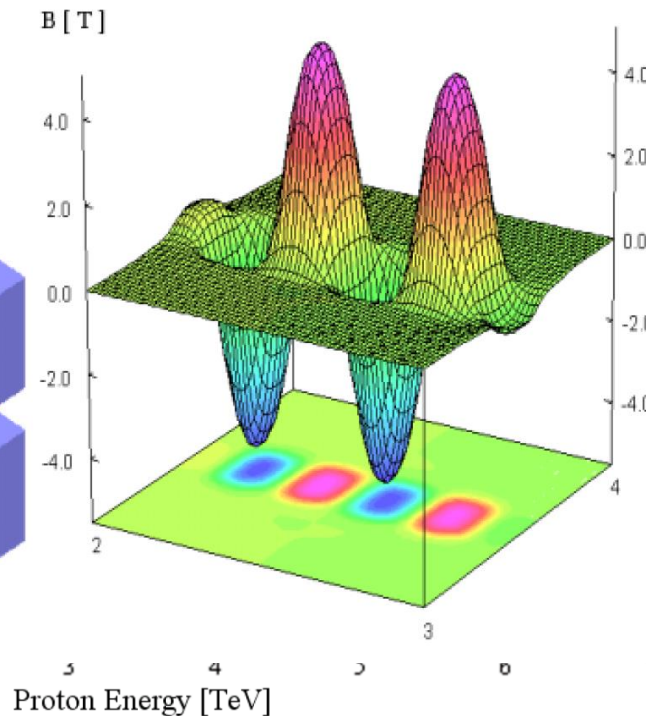
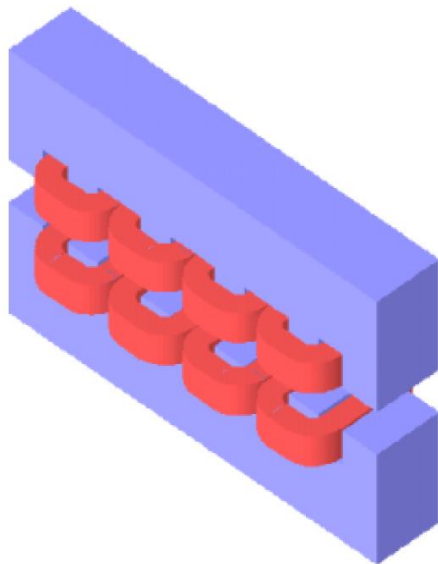

Synchrotron Light in the LHC

- Beam Synchrotron Radiation Telescope
 - BSRT located in Point 4 of the LHC

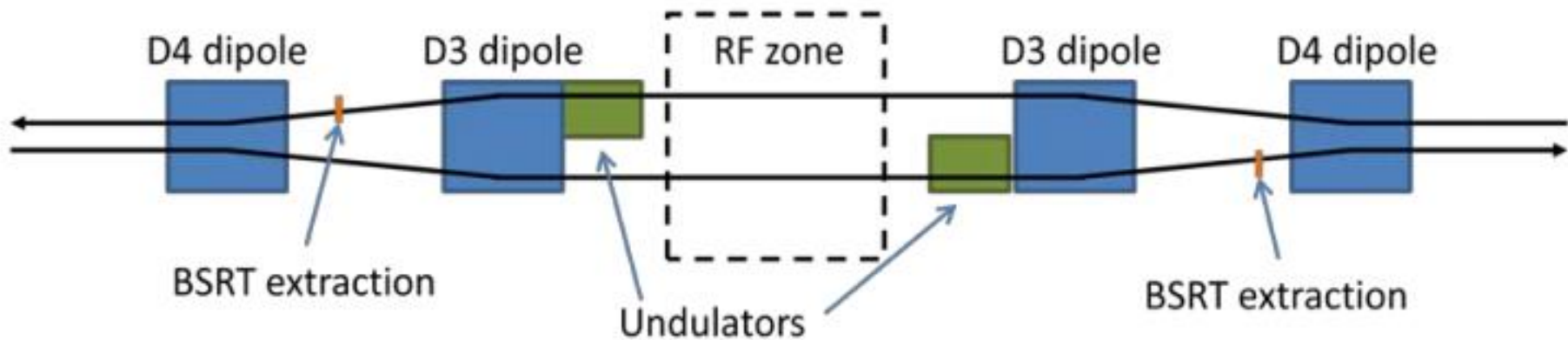

Synchrotron Light in the LHC

- Beam Synchrotron Radiation Telescope

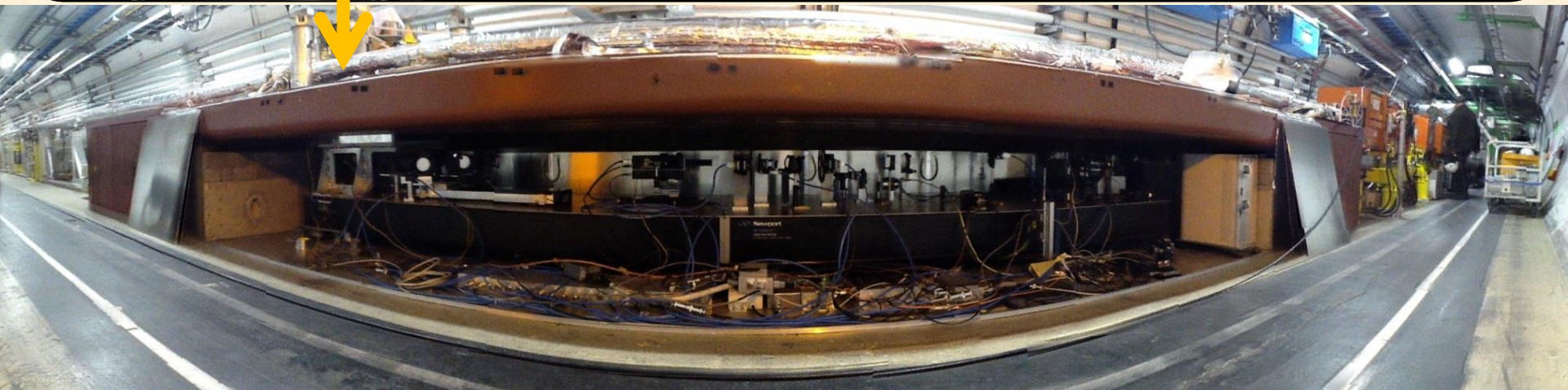
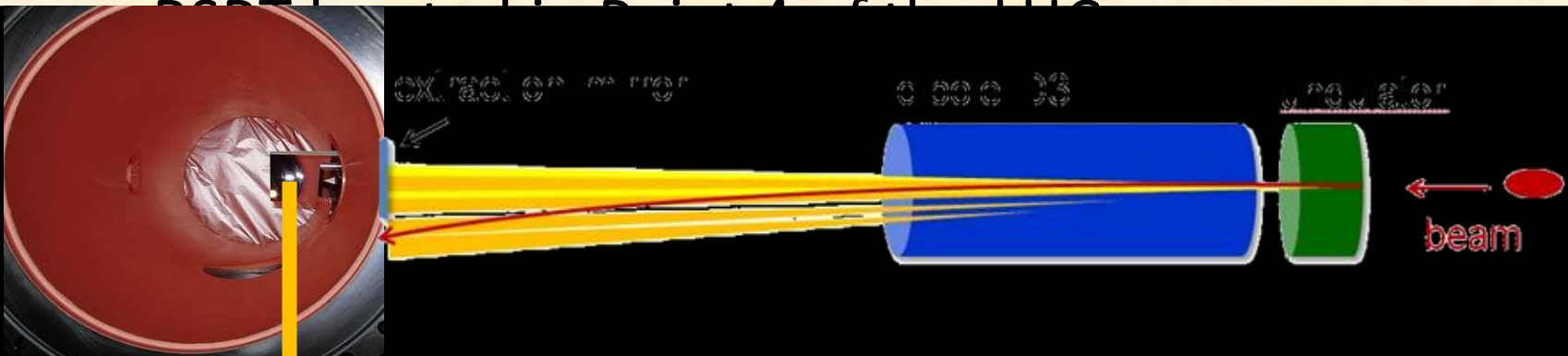

Image Acquisition in the LHC

- Using a gated intensified camera

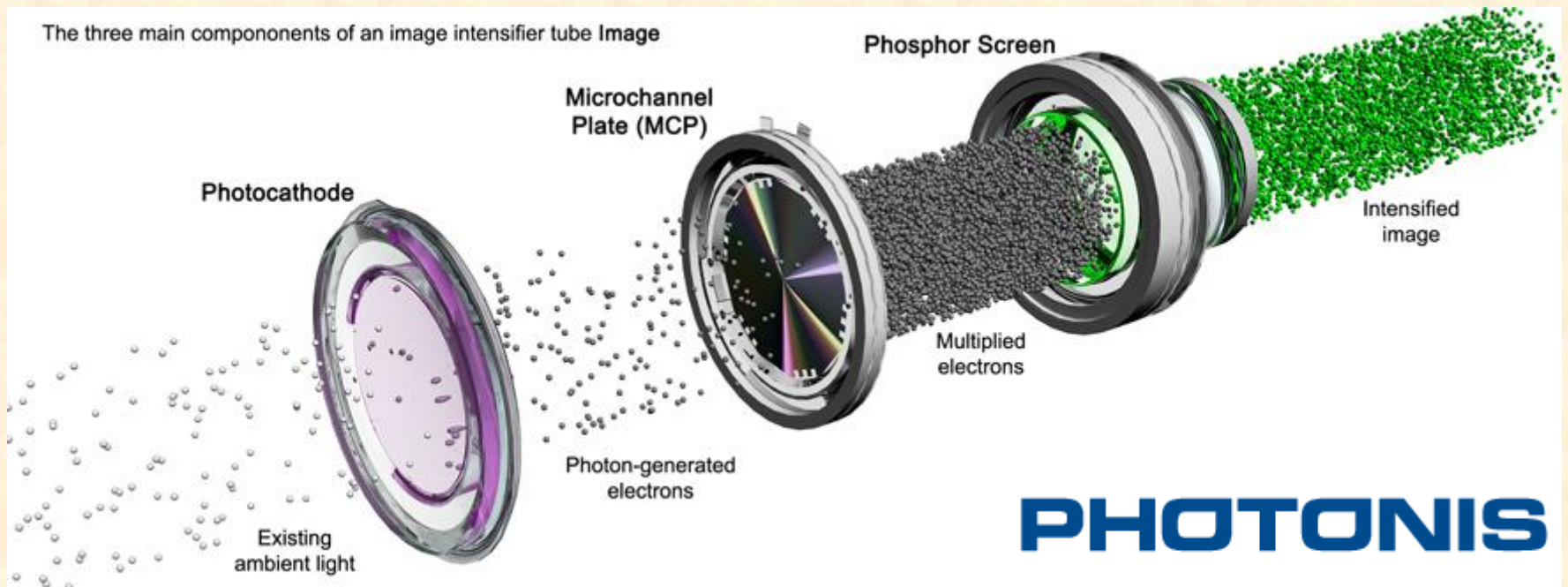
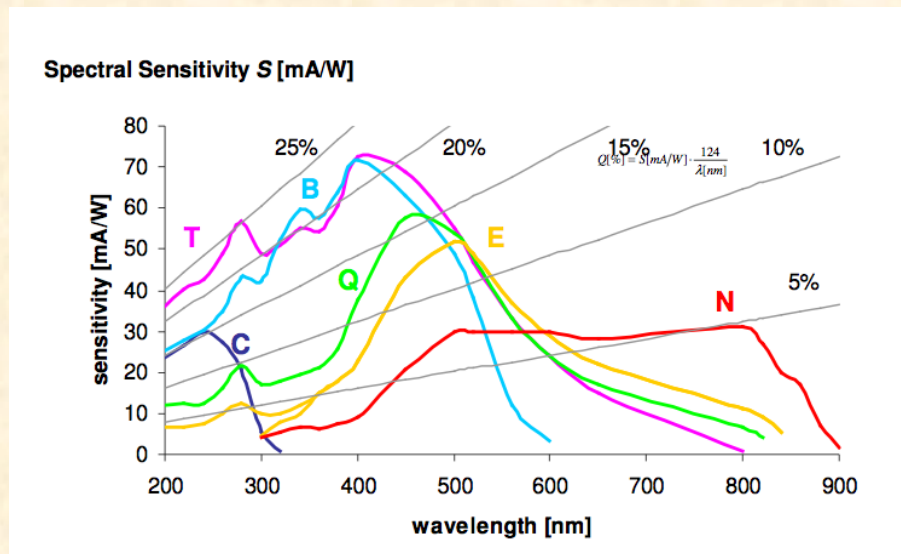

Image Acquisition in the LHC

- Proxitronic gated intensified camera
 - Intensifier max trigger rate : 200 Hz (~55 LHC turns)
 - Intensifier min gating : 25ns (1 LHC bucket)
- Present max acquisition rate is 10Hz
 - On paper 10 bunches per second but slower to get statistics

Photocathode response

- cameras equipped with **N type** during Run I
- Will be equipped with **T type** for Run II
- Overall system sensitivity
 - Enough light to see
 - single proton pilot bunch (5e9p) on a single turn at injection (450GeV)
 - ~20 Ion Pb bunches at injection, averaged over 4 turns



Proton Image Example

- Beam
 - Single bunch $\sim 1.1e11p$ @ 3.5 TeV
- Acquisition
 - Accumulated over 4 turns at 200Hz

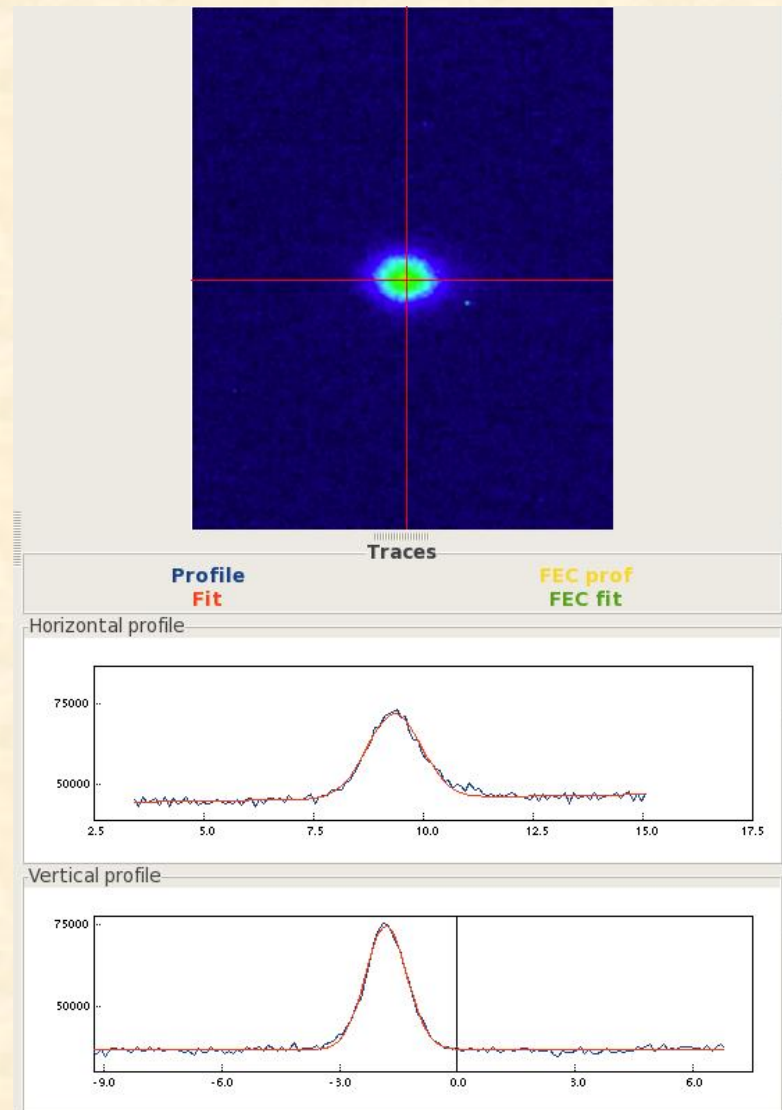

Beam Size Measurement with Synchrotron Light

- Imaging Resolution

Abserrations (spherical, chromatic, surface irregularity...) $\rightarrow \sigma_{aberr}$

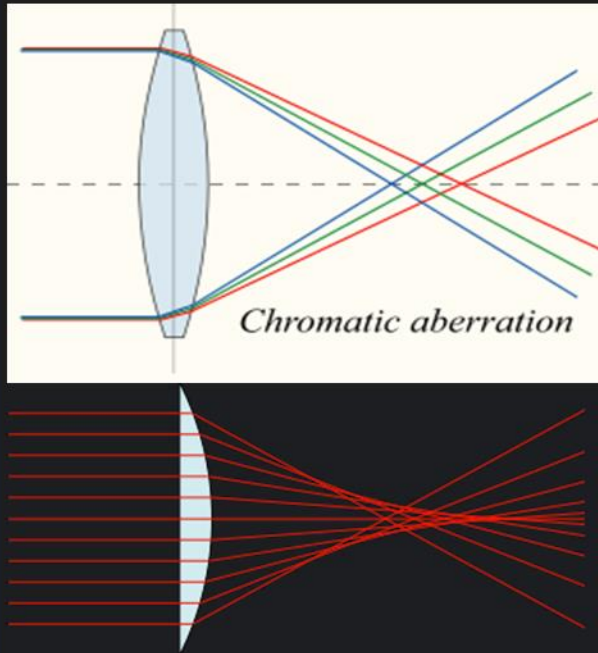

fundamental resolution limit (diffraction) $\rightarrow \sigma_{diff}$

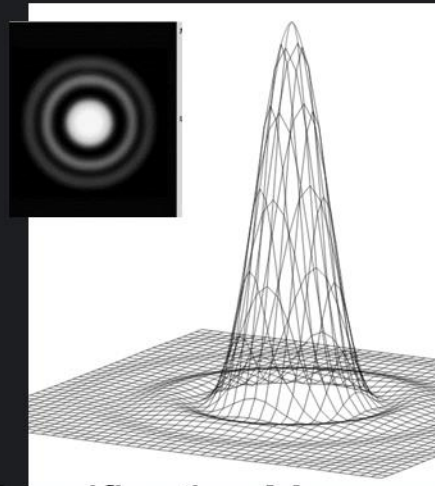

Magnification M

$$\Delta x = 0.61 \frac{M\lambda}{\sin \theta}$$

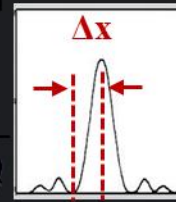

extended object (depth of field) moving object $\rightarrow \sigma_{dof}$

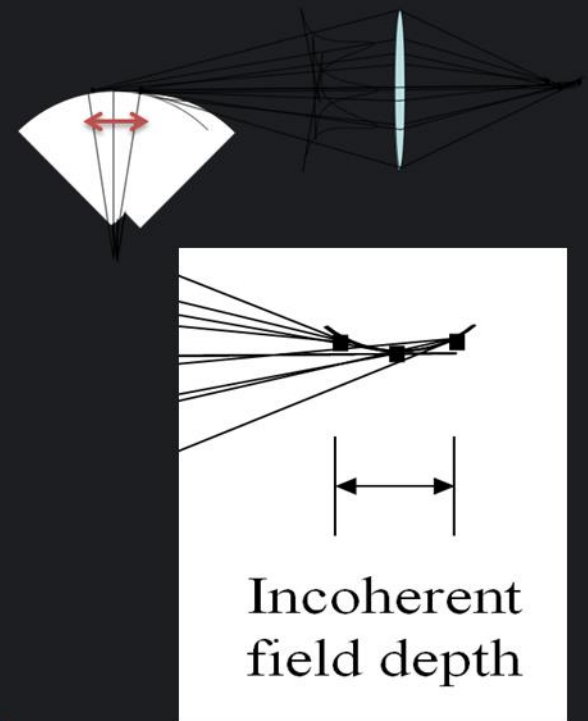

Incoherent field depth

Synchrotron light limitations in the LHC

- $\sigma_{\text{correction}}$
 - Difficult to model accurately & simulate
 - Therefore experimentally measured, knowing the real beams size
 - WireScanner cross calibration
- Size measured has to be de-convoluted by a correction factor to obtain the real size
 - For LHC correction factor is of same order as real beam size

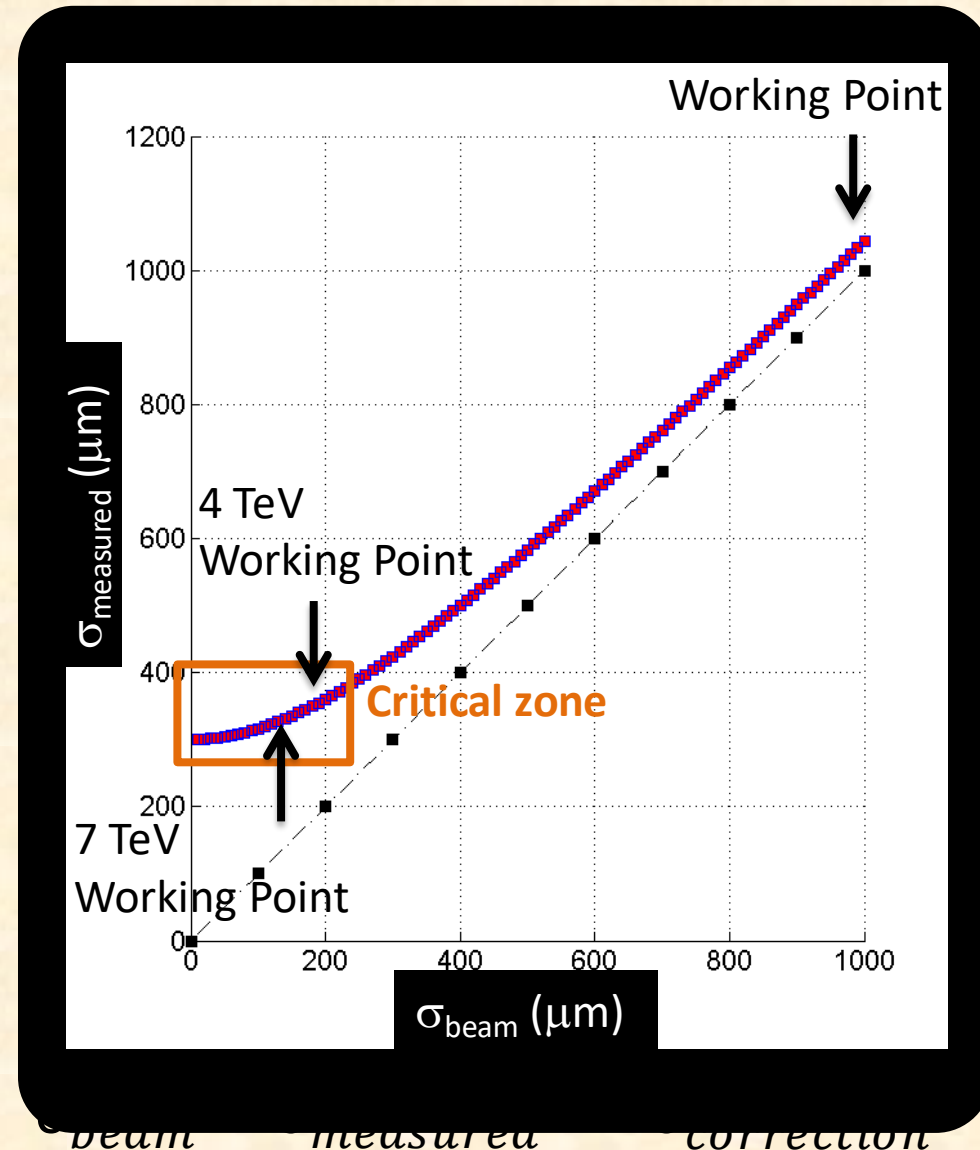

σ_{beam} σ_{measured} correction

(most slides courtesy of Dr Rhodri Jones and J. Wenninger)

MACHINE PROTECTION AND BEAM LOSS MONITORS

1232 NbTi superconducting dipole magnets – each 15 m long
Magnetic field of 8.3 T (current of 11.8 kA) @ 1.9 K (super-fluid Helium)

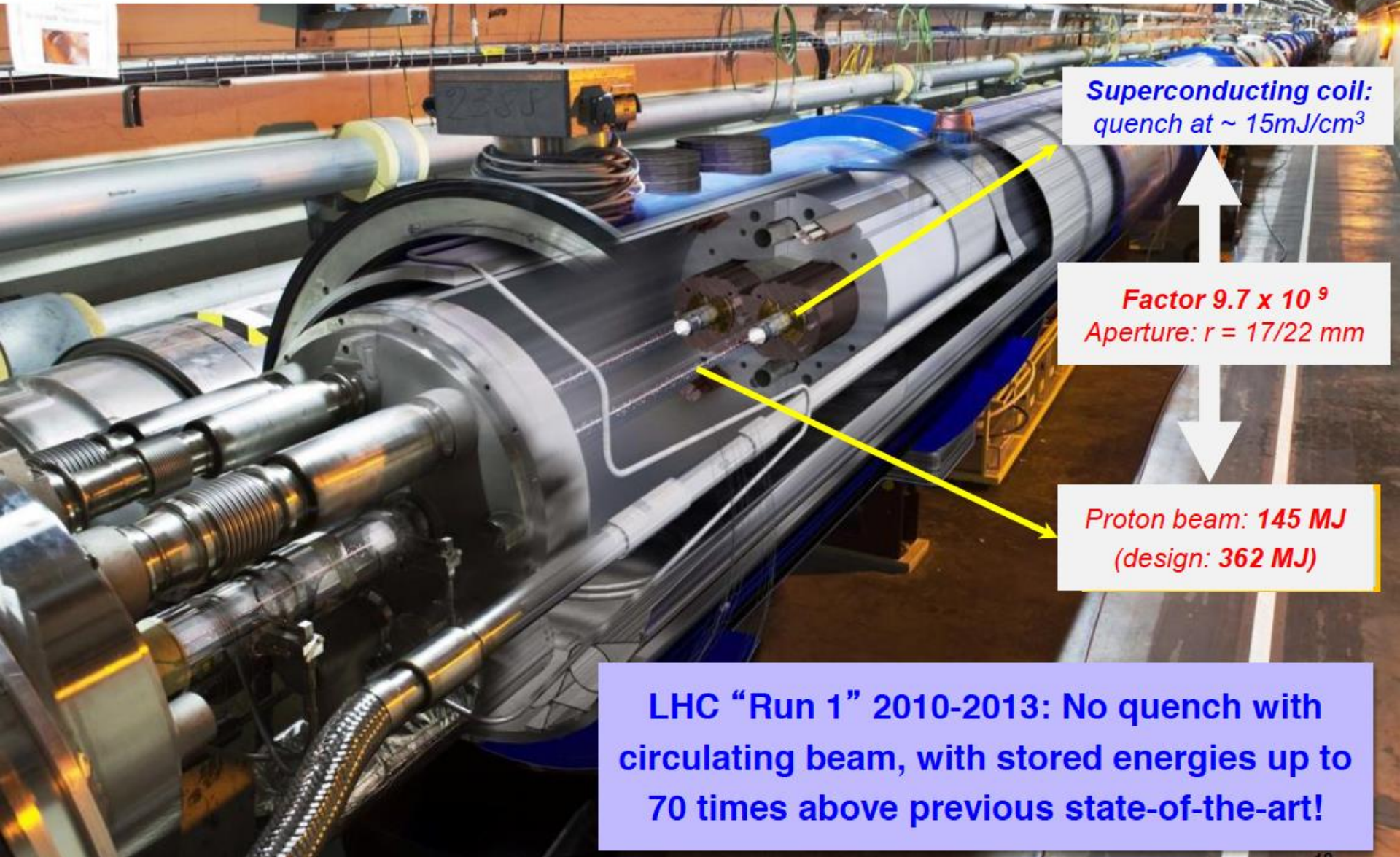

*Superconducting coil:
quench at $\sim 15\text{mJ/cm}^3$*

*Factor 9.7×10^9
Aperture: $r = 17/22\text{ mm}$*

*Proton beam: 145 MJ
(design: 362 MJ)*

LHC “Run 1” 2010-2013: No quench with circulating beam, with stored energies up to 70 times above previous state-of-the-art!

LHC pushes the stored energy from few MJs to > 100 MJs

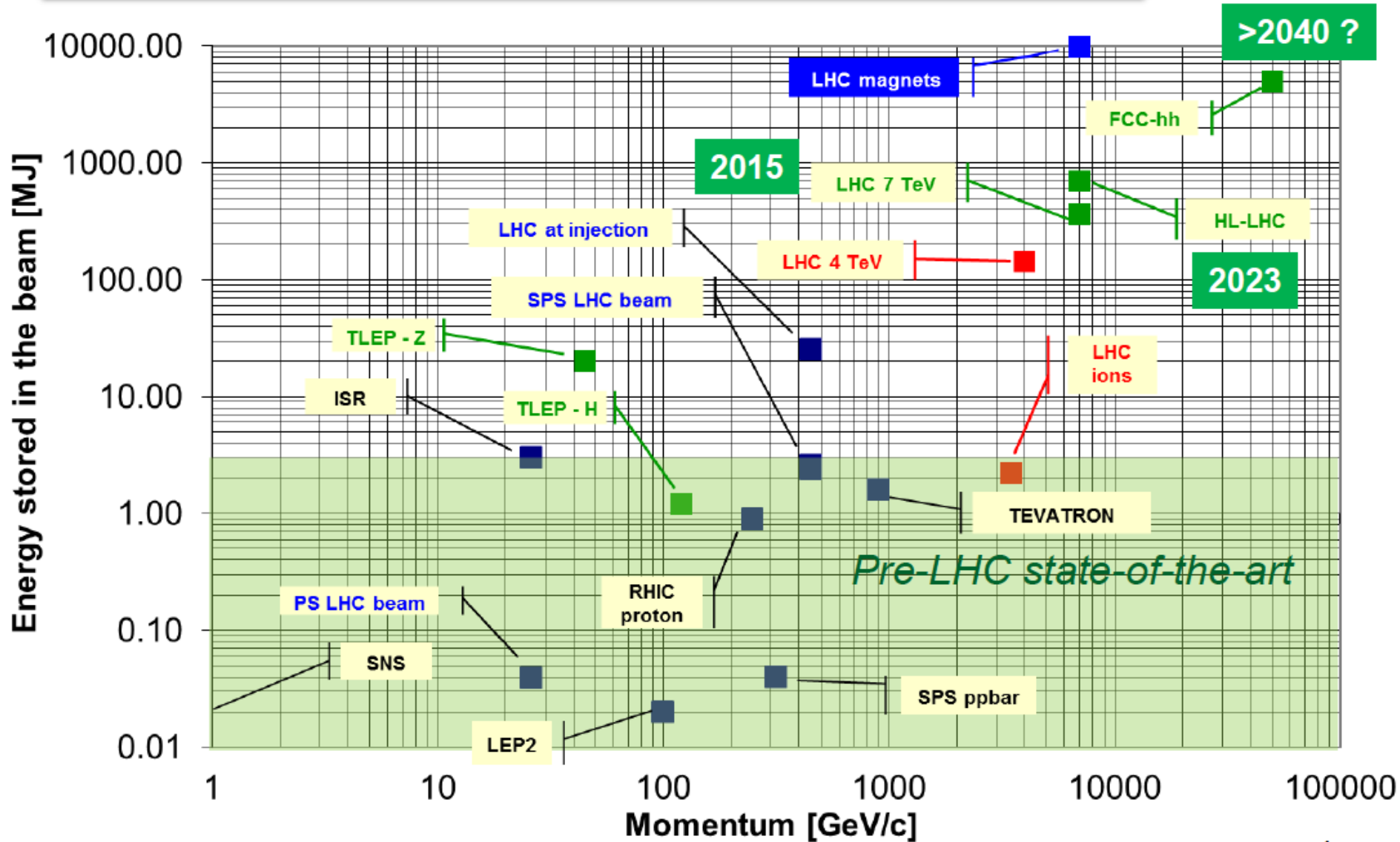

Energy (TeV)

7 TeV Design



5 TeV

Magnet de-training after installation



Joint problems, incident

3.5 TeV



Consolidation delays

1.18 TeV

3.5 TeV

Operation



Energy increase \Leftrightarrow no quench at 3.5 TeV

4 TeV

Operation

Long Shutdown 1 (LS1)

Consolidation of all interconnections



> 6.5 TeV

2007

2008

2009

2010

2011

2012

2013

2014

2015

Collimation system

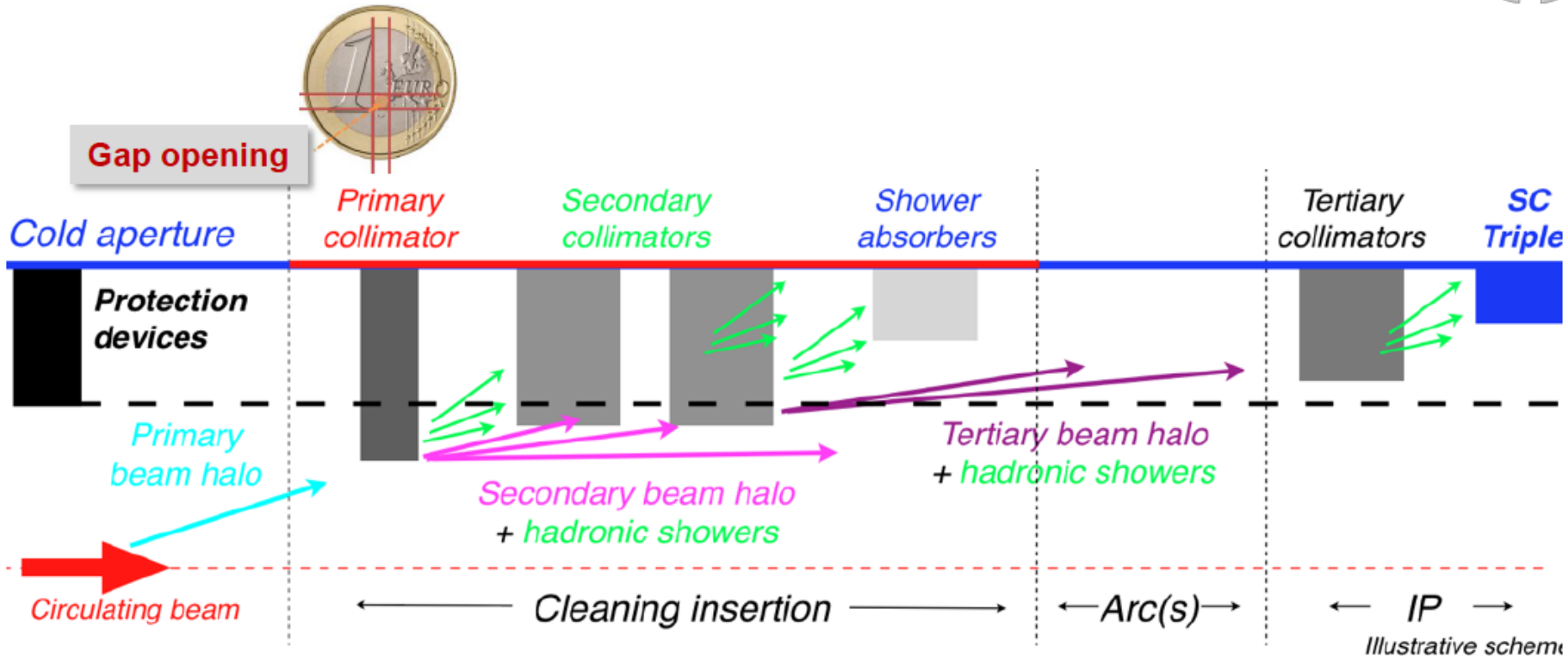

- ❑ To be able to absorb the energy of the 7 TeV proton, the LHC requires a **multi-stage collimation system** – primary, secondary, tertiary.
- ❑ The system worked perfectly so far – thanks to **excellent beam stabilization and machine reproducibility** – only one full collimation setup / year.
 - ~99.99% of the protons that were lost from the beam were intercepted.

MPS

- ❑ The LHC beam interlock system (BIS) has 189 inputs from client systems (including injection).
- ❑ Behind each input that can be many individual tests / interlocks.

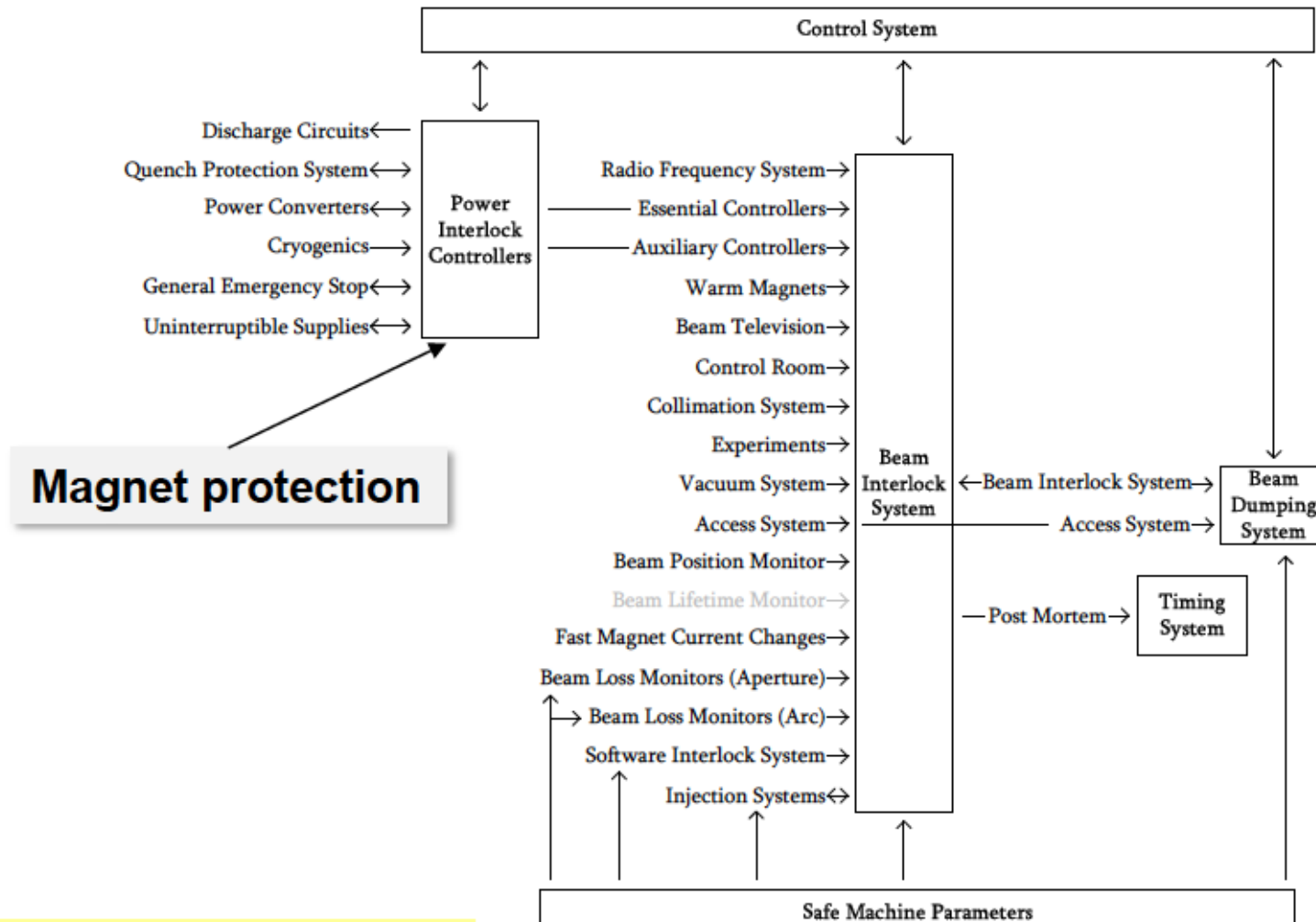

Beam permit

see lecture by R. Schmidt

Loop signal propagation in clockwise and counter-clockwise directions

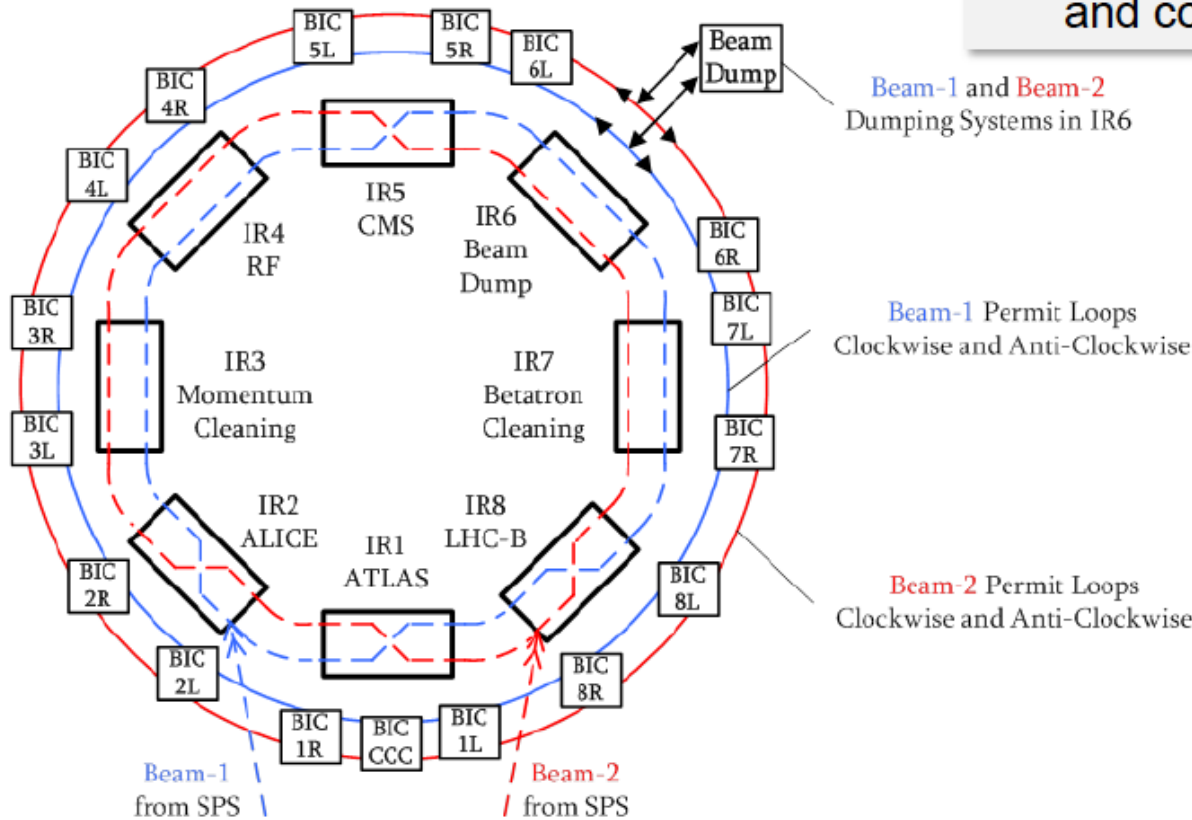

4 beam permit loops
2 permit loops / beam

Direct link to LHC injection and SPS extraction

- no beam permit
- no injection/extraction

unacceptable danger exists

beam dump completed

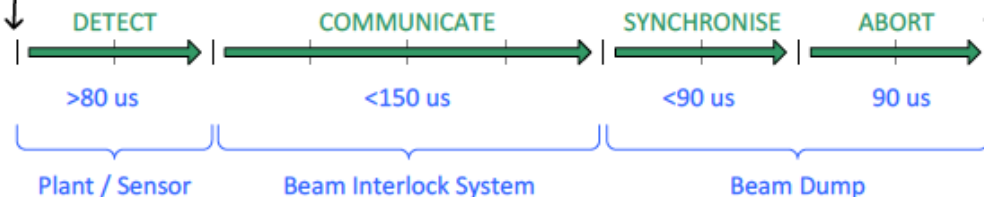

At the LHC the dump delay can reach ~3 turns – ~300 μs

How to get rid of the beams?

- With so much energy stored in the beams they have to be disposed of with care.
- A special area “dumps” has been designated and instrumented for this purpose.
- All the energy can not be disposed of on a single point.

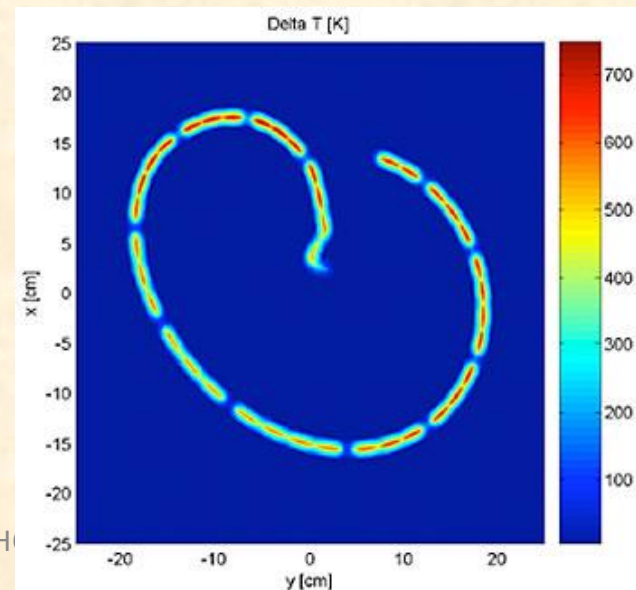
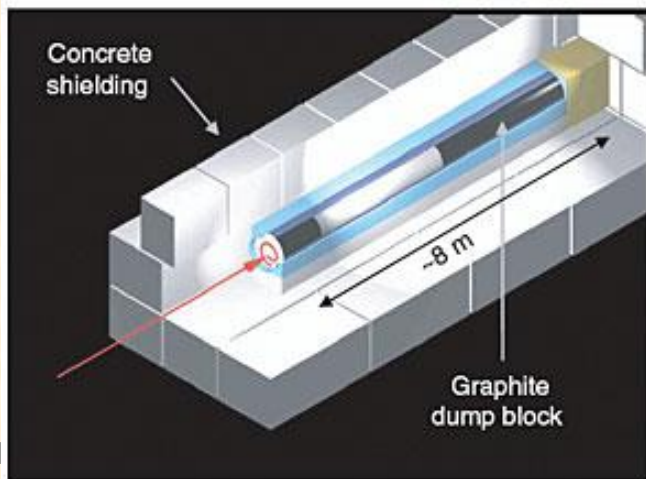
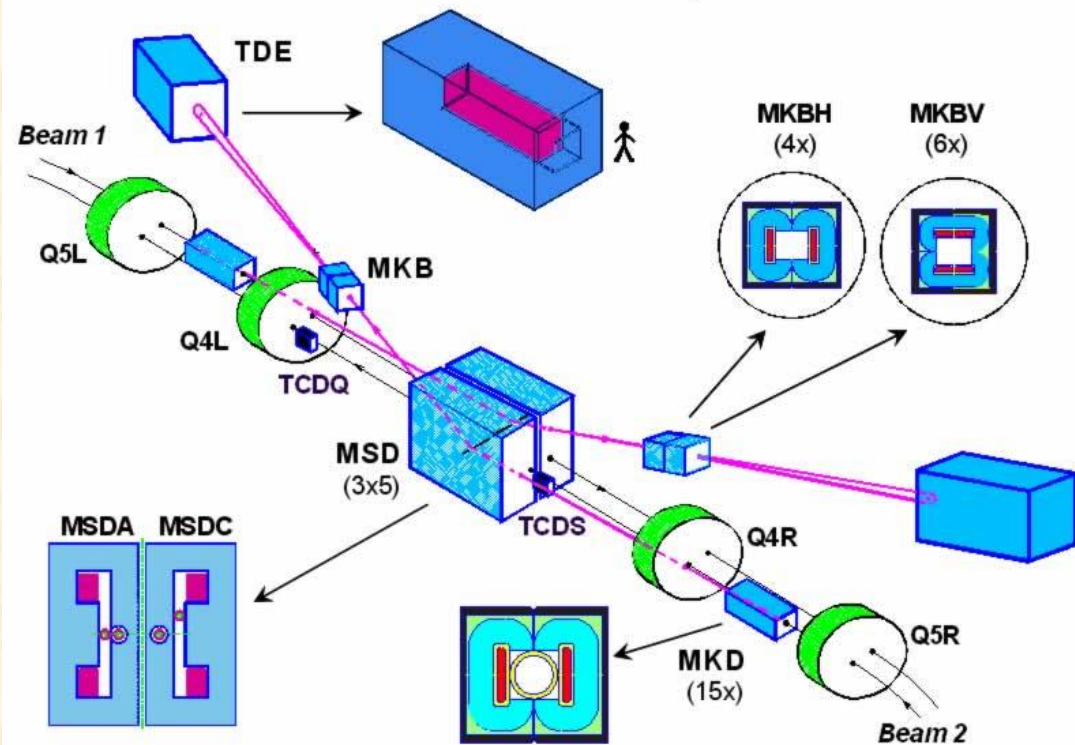

LHC beam dump

A complex system, and yet it must be ultra-highly reliable!

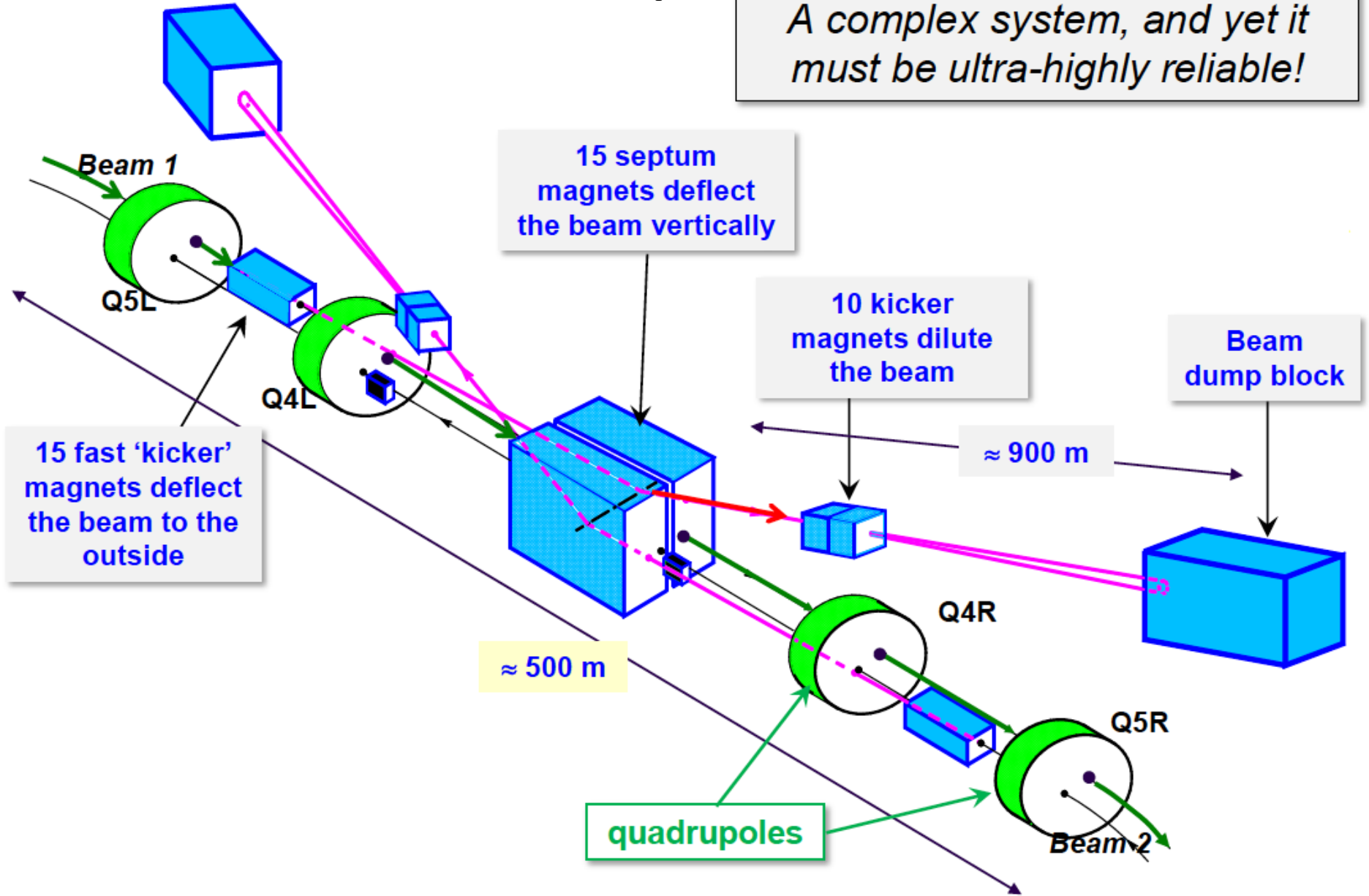





The dump block is the only LHC element capable of absorbing the nominal beam.
The beam is swept over dump surface to lower the power density.

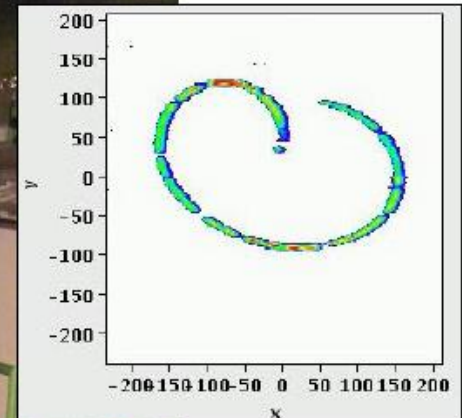

Without the sweep the beam could drill a hole with a depth of a few meters into the block !
Hydro-dynamic tunnelling

Beam dump synchronisation

- ❑ The beam dump must be accurately synchronized to the **beam abort gap** to avoid spreading beam across the aperture during the kicker rise-time.
- ❑ The **3 μ s long beam abort gap** must be ... free of beam !
- ❑ Possible failure modes:
 - The abort gap fills with beams (RF fault, debunching, injection error),
 - The kicker synchronization fails,
 - A kicker fires spontaneously (not synchronized).

**Asynchronous
dump failure**

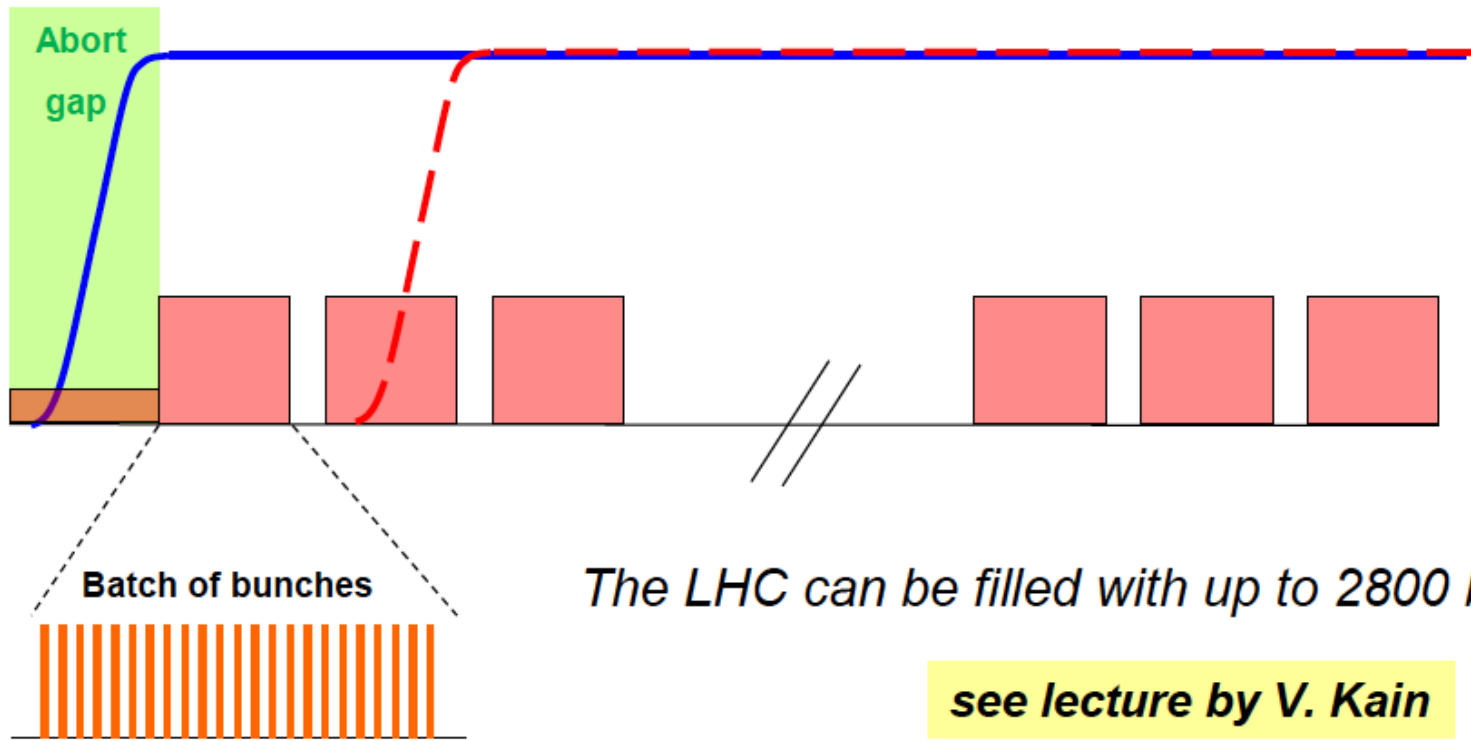

LHC incident on September 19th 2008

- Last commissioning step of one out of the 8 main dipole electrical circuit in sector 34 : ramp to 9.3kA (5.5 TeV).

- At 8.7kA an electrical fault developed in the **dipole bus bar** located in the interconnection between quadrupole Q24.R3 and the neighboring dipole.

Later correlated to a local resistance of $\sim 220\text{ n}\Omega$ – nominal value $0.35\text{ n}\Omega$.

- An electrical arc developed which punctured the helium enclosure.

Secondary arcs developed along the arc.

Around 400 MJ from a total of 600 MJ stored in the circuit were dissipated in the cold-mass and in electrical arcs.

- Large amounts of Helium were released into the insulating vacuum.

In total 6 tons of He were released.

This incident involved magnet powering, but no beam!

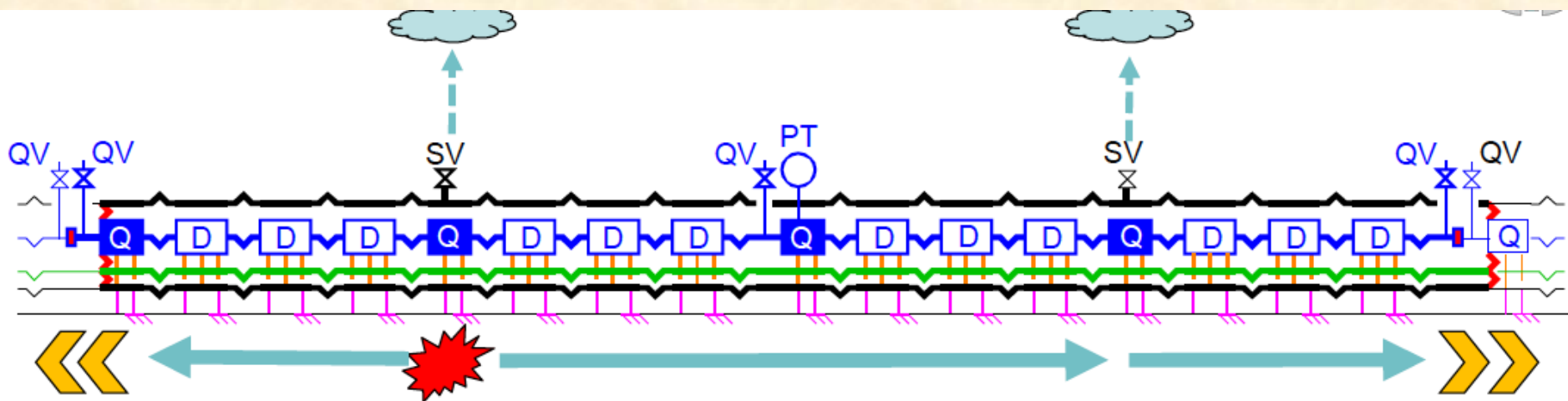

- Cold-mass
- Vacuum vessel
- Line E
- | Cold support post
- | Warm Jack
- ~ Compensator/Bellows
- ⚡ Vacuum barrier

- ❑ Pressure wave propagates along the magnets inside the insulating vacuum enclosure.
- ❑ Rapid pressure rise :
 - Self actuating relief valves could not handle the pressure.
designed for 2 kg He/s, incident ~ 20 kg/s.
 - Large forces exerted on the vacuum barriers (every 2 cells).
designed for a pressure of 1.5 bar, incident ~ 8 bar.
 - Several quadrupoles displaced by up to ~50 cm.
 - Connections to the cryogenic line damaged in some places.
 - Beam vacuum to atmospheric pressure.

The Helium pressure wave damaged ~600 m of LHC, polluting the beam vacuum over more than 2 km.

Arcing in the interconnection



53 magnets had to be repaired



Over-pressure

Magnet displacement



Beam Loss Detection

- Role of a Beam Loss Monitor (BLM) system:
 - Protect the machine from damage
 - Dump the beam to avoid magnet quenches (for SC magnets)
 - Diagnostic tool to improve the performance of the accelerator

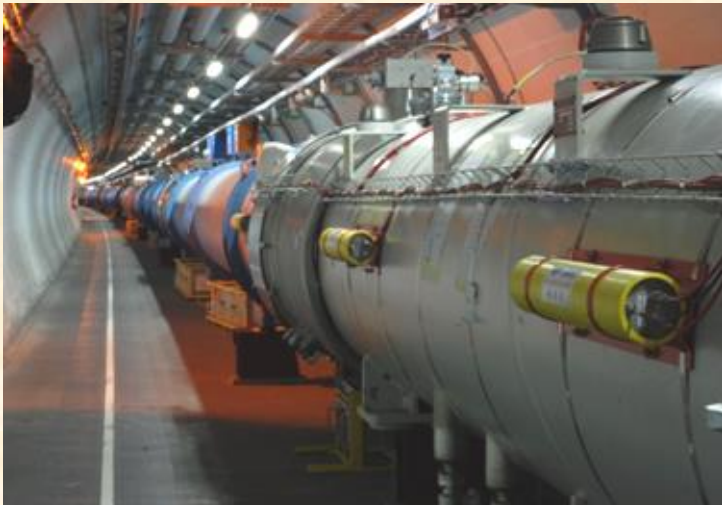

Machine Protection

- Failure in protection
 - loss of complete LHC is possible
- Magnet damage
 - months of downtime & significant cost
- Magnet quench
 - hours of downtime

Stored Energy

Beam 7 TeV	2 x 362 MJ
2011 Beam 3.5 TeV	above 2 x 100 MJ
Magnets 7 TeV	10 GJ

Quench and Damage at 7 TeV

Quench level	$\approx 1 \text{ mJ/cm}^3$
Damage level	$\approx 1 \text{ J/cm}^3$

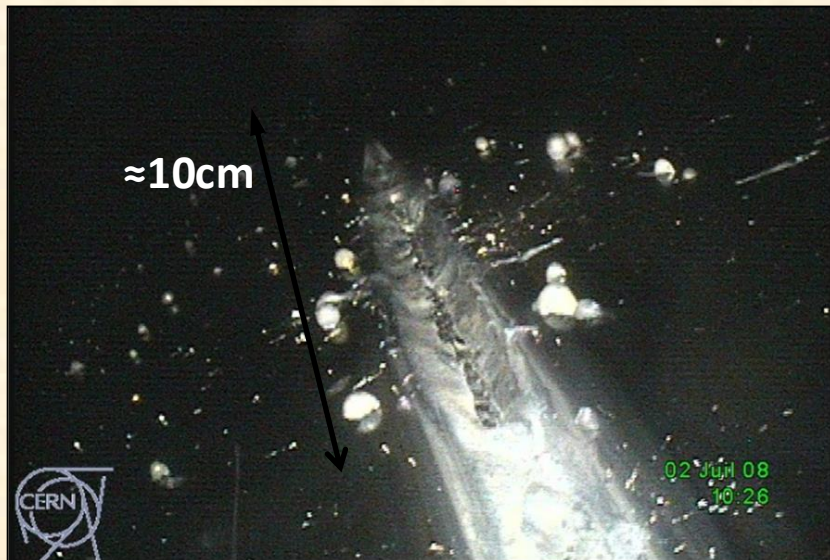

- **SPS incident**
 - June 2008
 - 2 MJ beam lost at 400GeV

The LHC Machine Protection System

- Over 20,000 channels from ~250 user input connections

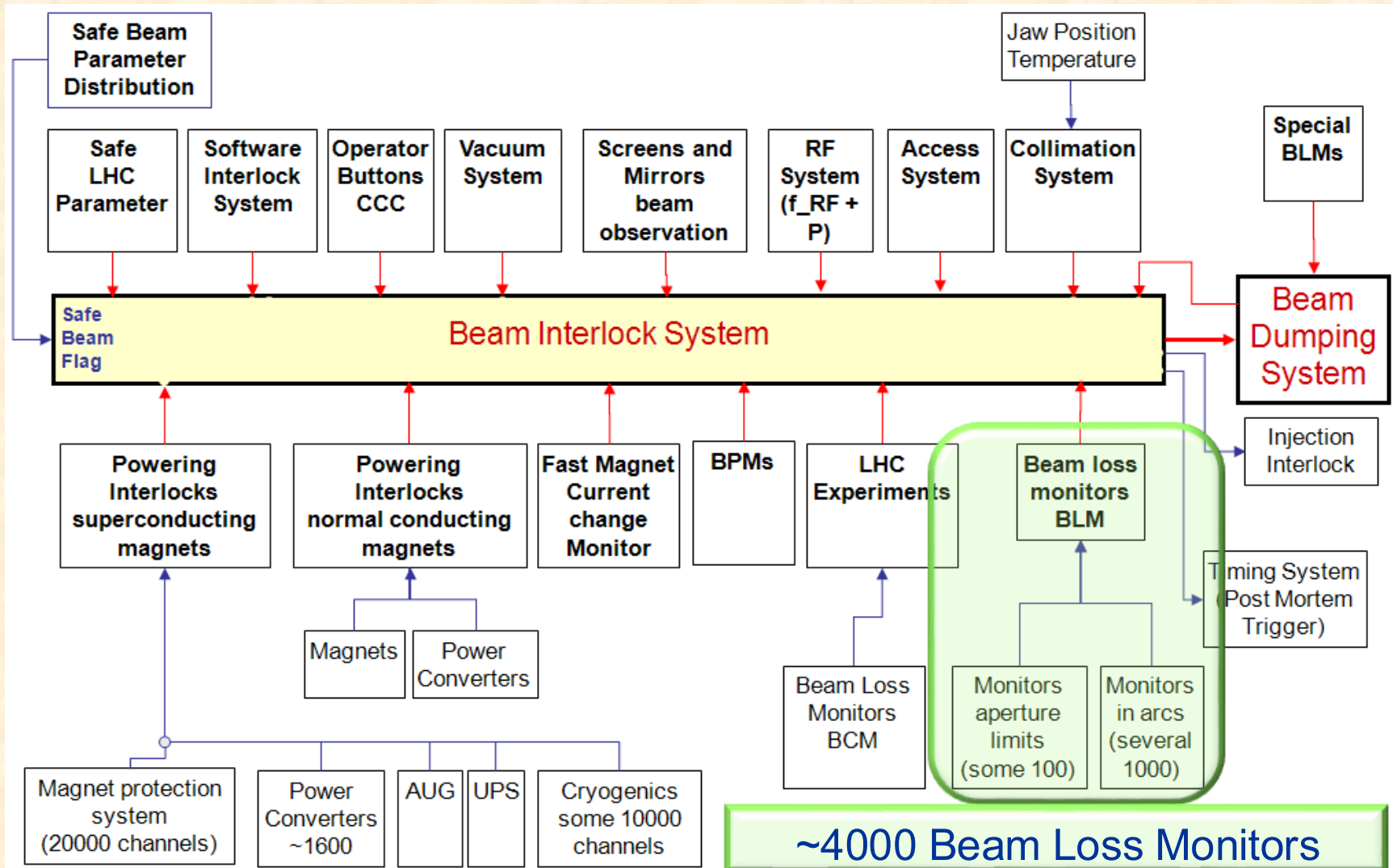

Beam Loss Durations

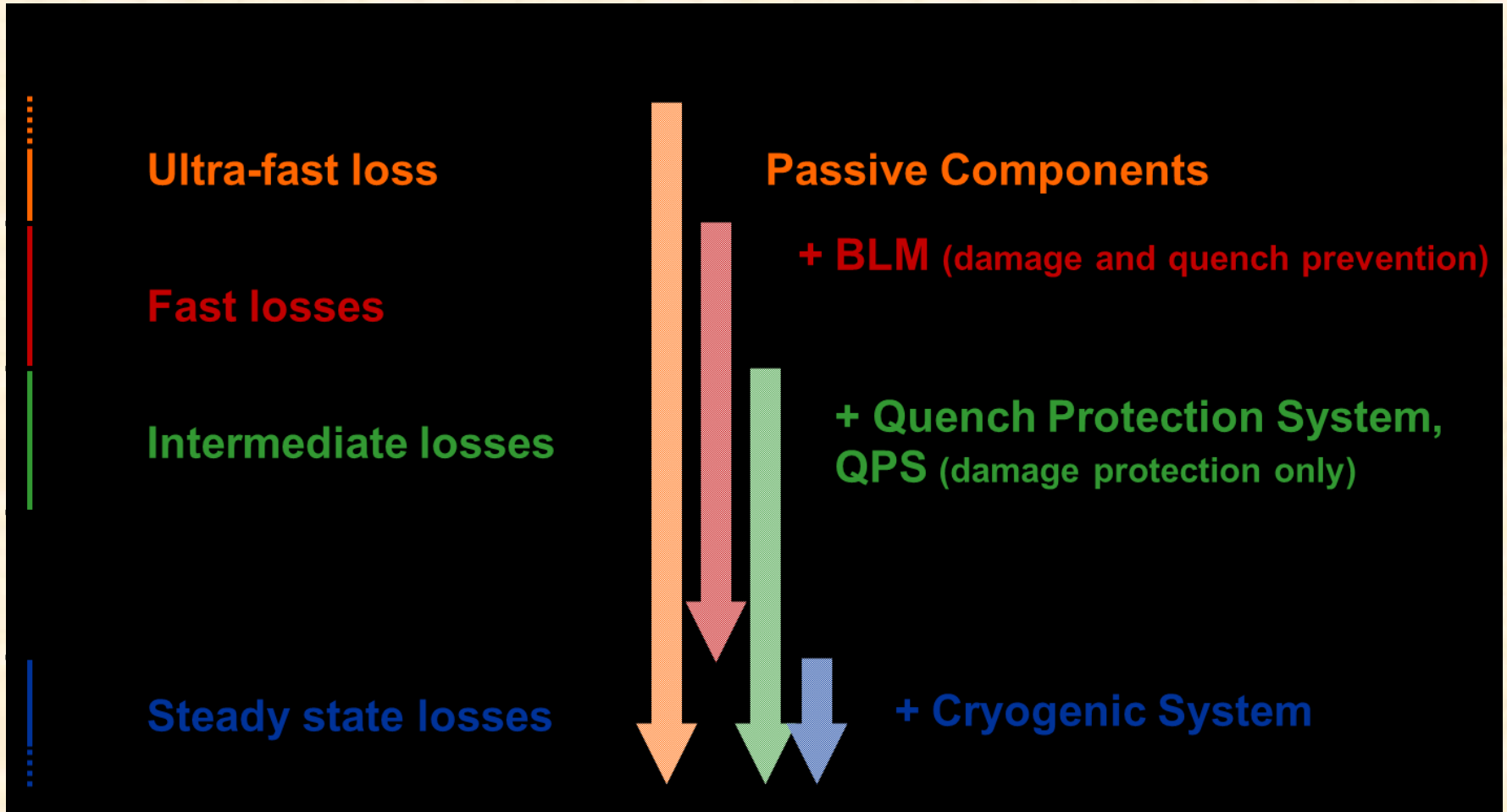

- LHC BLM System
 - Main system to prevent magnet damage from multi-turn beam losses
 - Only system to prevent magnet quench

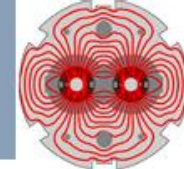

- Ionization chambers are used to detect beam losses:
 - Very fast reaction time $\sim \frac{1}{2}$ turn ($40 \mu\text{s}$)
 - Very large dynamic range ($> 10^6$)
- ~3600 chambers (BLMS) are distributed over the LHC to detect beam losses and trigger a beam abort !
- BLMs are good for almost all failures as long as they last \sim a few turns (few 0.1 ms) or more !

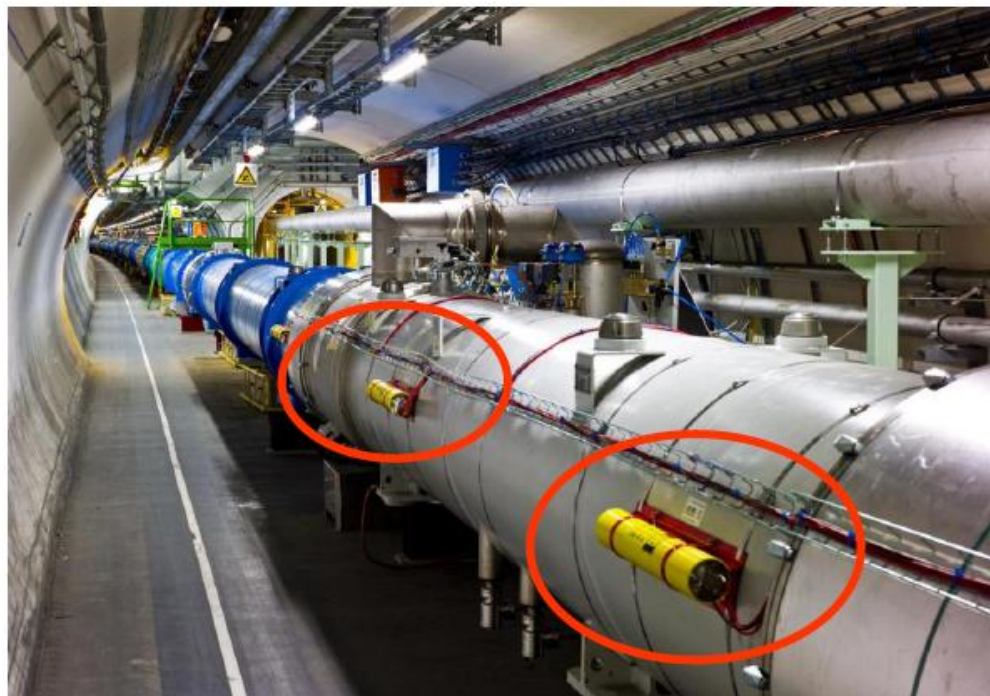

BLM System Challenges

- Design Specifications
 - Reliability
 - tolerable failure rate 10^{-7} per hour per channel $\Rightarrow 10^{-3}$ magnets lost per year (assuming 100 dangerous losses per year)
 - Implies
 - Reliable components, radiation tolerant electronics
 - Redundancy, voting
 - Monitoring of availability and drift of channels
 - Less than 2 false dumps per month (operation efficiency)
 - High dynamic range 10^{13}
 - Fast (1 turn, $89 \mu\text{s}$) trigger generation for dump signal
 - Quench level determination with uncertainty of factor 2
 - Extensive simulations and measurements
 - Threshold values a function of loss duration and beam energy

Loss Scenarios in the LHC

- Orbit bumps or combination of orbit bump & fast perturbation
 - Much of the LHC controlled automatically with feedbacks
- Leakage from collimation regions
 - Debris reach cold magnets in dispersion suppressors
- Luminosity debris
 - mainly for inner triplets
- Injection losses
- Unidentified Falling Objects (UFOs)
 - anywhere around the ring (more on this later)
- Ion losses
 - Secondary ion beam with different charge / mass ratio
 - Around experiments: Bound-free pair production at the IPs
 - Around collimation regions: nuclear processes in primary collimator
 - Highly localised in dispersion suppressors

Detection Principle for main LHC BLMs

Visualisation of ion chamber operation

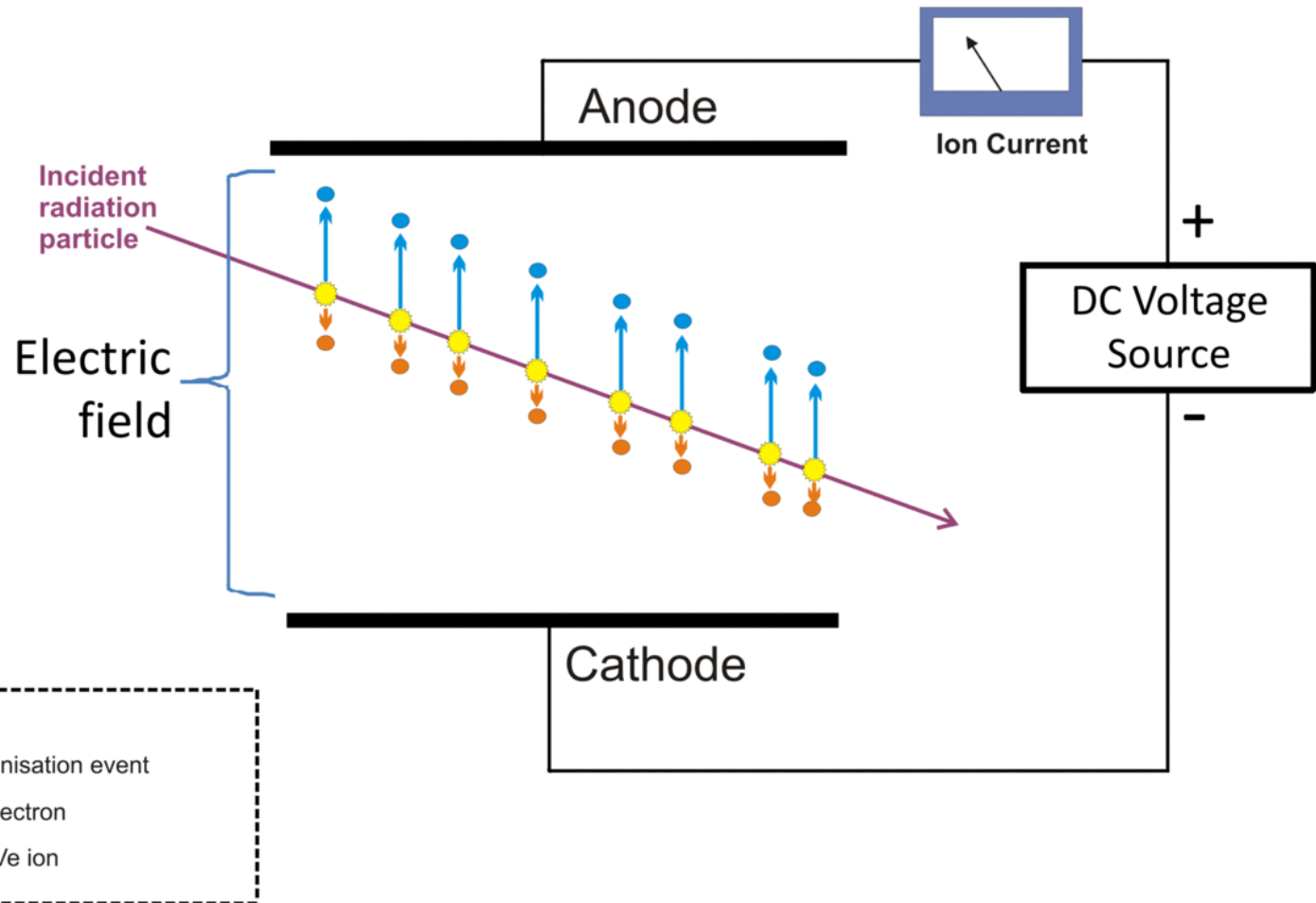

The LHC BLM System

- Ionisation chamber

- ~3600 installed
- Gas filled with many metallic electrodes & kV bias
 - Length 50 cm
 - Sensitive volume 1.5 litre N₂ gas filled at 1.1 bar
- Speed limited by ion collection time
- Dynamic range of up to 10⁹
 - Limited by leakage current through ceramic & saturation

- Secondary emission monitor

- ~300 installed
- Vacuum filled, few electrodes & kV bias
 - Length 10 cm
 - pressure < 10⁻⁷ bar
- Complements ionisation chamber
 - ~70,000 times smaller gain

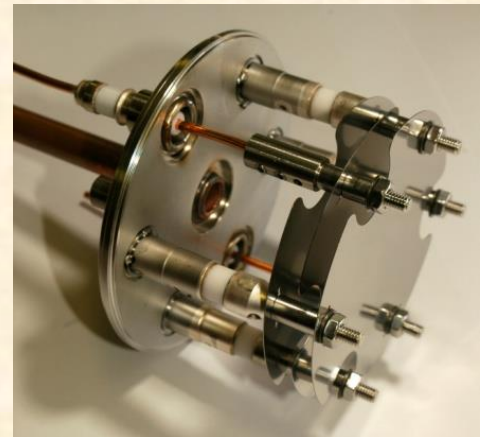

Ionisation Chamber Response

- Sensitivity $54 \mu\text{C}/\text{Gy}$
- Time response
 - Electron collection 150 ns
 - Ion collection time 80% at $89 \mu\text{s}$
- Absolute calibration $\pm 30\%$
- Dynamic (linear range)
 - minimum current $< 1 \text{ pA}$
 - maximum current 10 mA
- Radiation tolerance
 - Gain variation:
 - $30 \text{ kGy } \Delta\sigma/\sigma < 0.01$
 - $100 \text{ MGy } \Delta\sigma/\sigma < 0.05$
 - OK for 30 years of operation

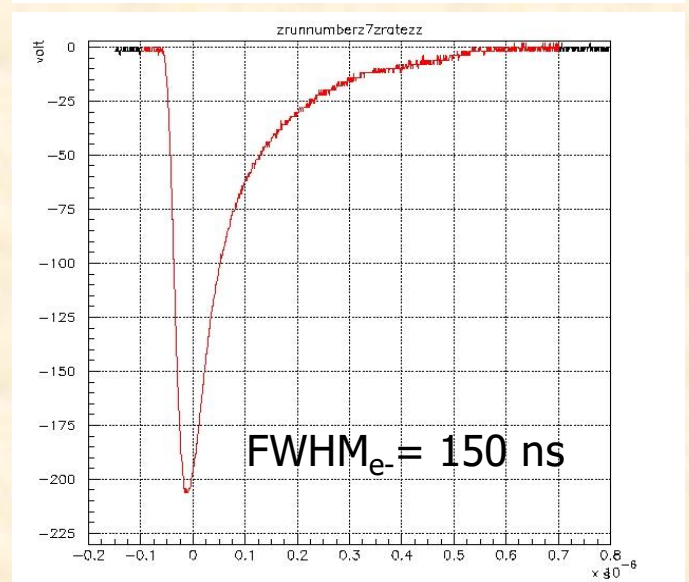
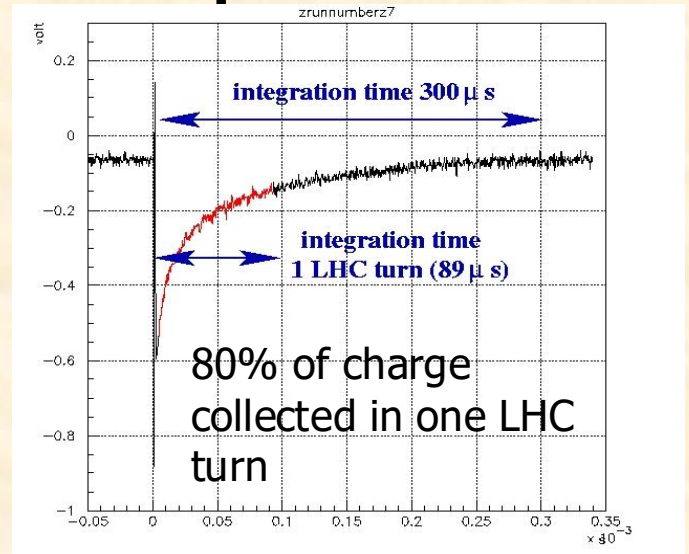

BLM System Electronics

- Linearity
 - Measures currents from tens of pA to 1mA
 - Corresponding frequency from few tenths of a Hz to a few MHz
 - Linearity better than 5%

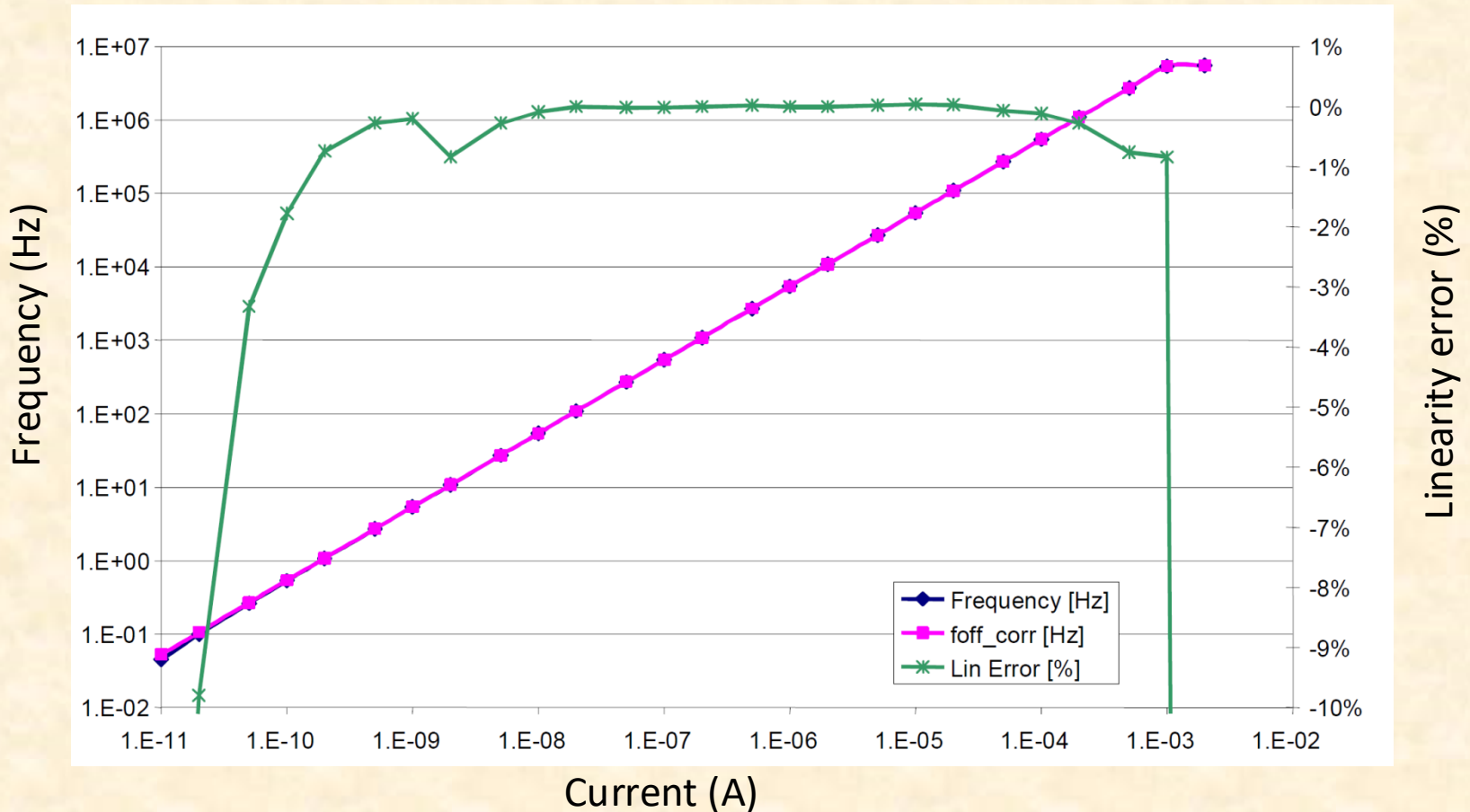

The BLM Acquisition System

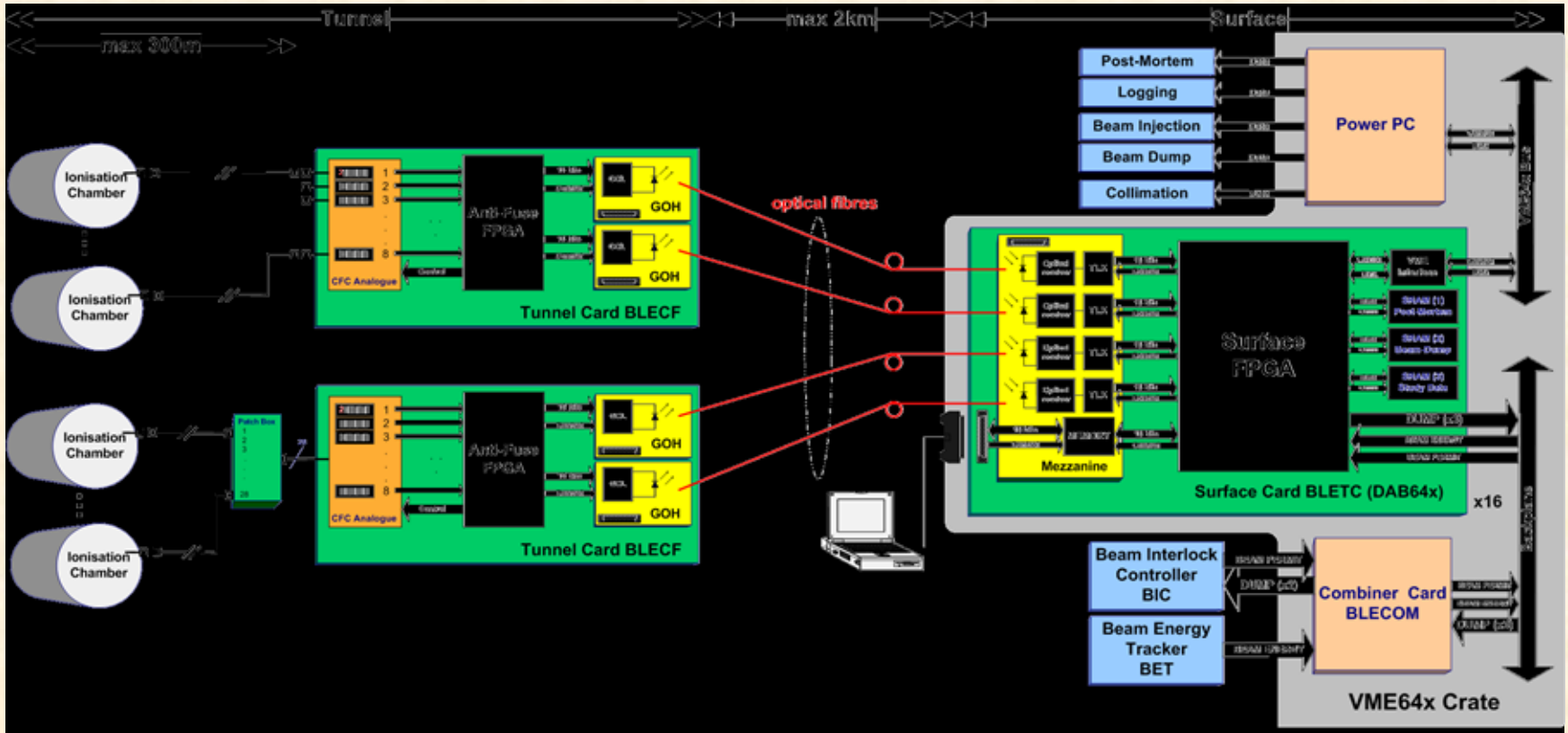

Tunnel electronics (Radiation Hard)

- Current to Frequency Converters (CFCs)
- Analogue to Digital Converters (ADCs)
- Gigabit Optical Links

Surface electronics

- Gigabit Optical Receiver
- FPGA for data processing
- SRAM memory for temporary storage
- Non volatile RAM for system settings

Determining Thresholds via Simulations

- Particle tracking to determine most likely loss locations
 - Any aperture reduction concentrates location of particle impacts
 - Localises losses at high beta values & reduced aperture
 - Quadrupoles, where orbit deviation and beam size is largest

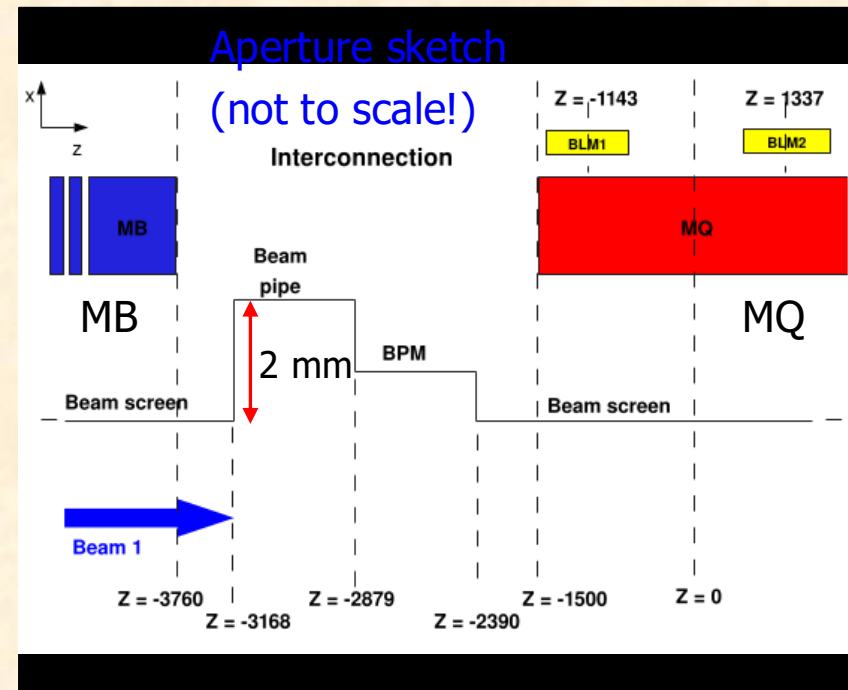
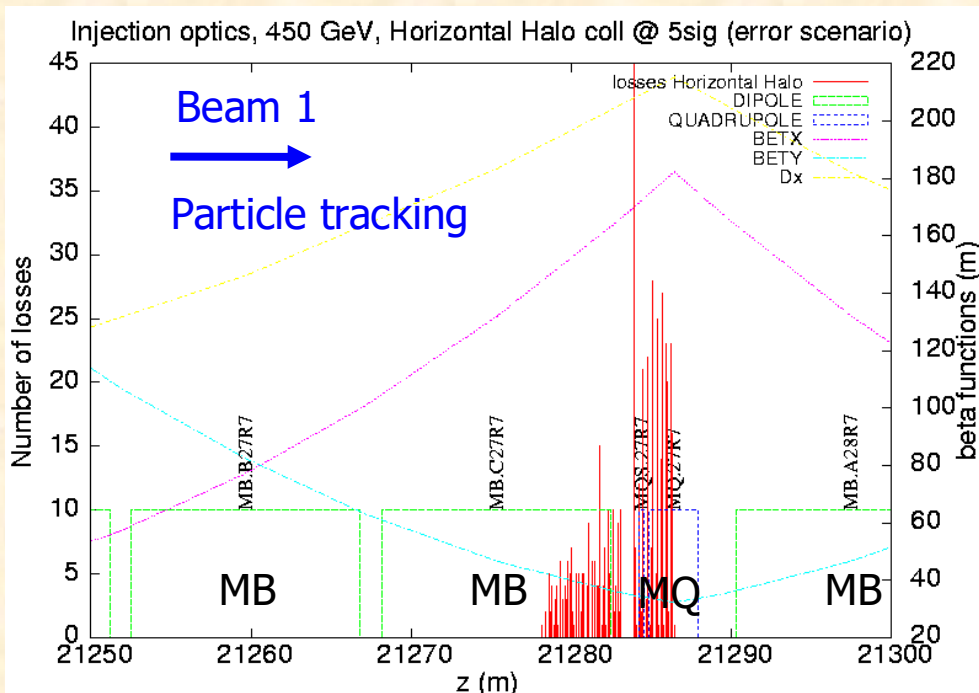

Thresholds Compared to Noise Levels

- Are the thresholds safely above the noise levels?
 - YES up to 5TeV but noise proportional to cable length
 - Better cable installed in LS1 to allow operation up to 7TeV
 - RadHard ASIC being developed for HL-LHC
 - Would allow mounting front-end electronics near BLM

Maximum Noise and Thresholds

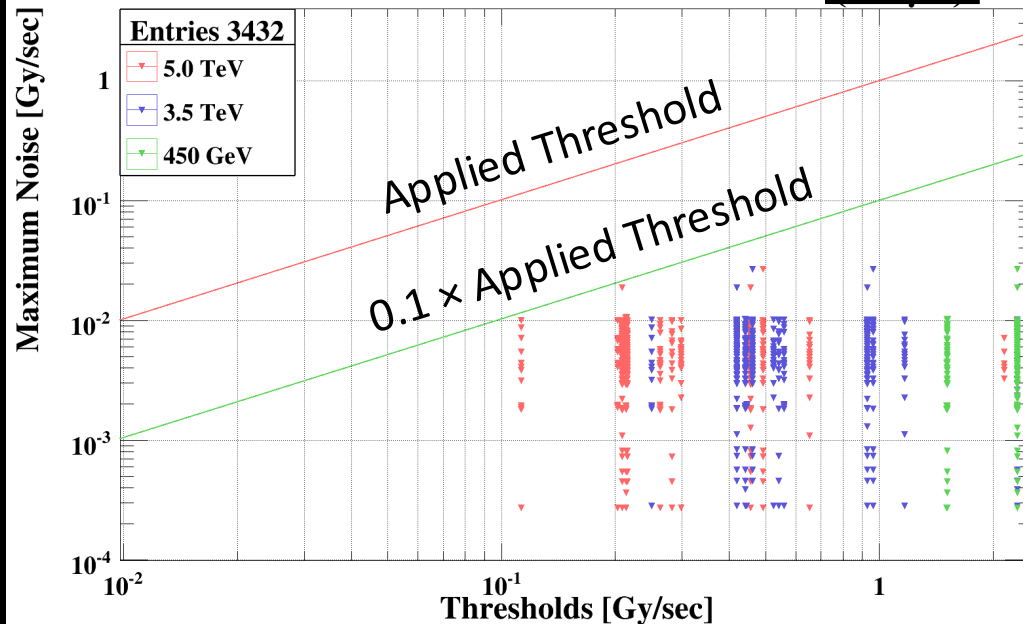

Cable length analysis: 20100207

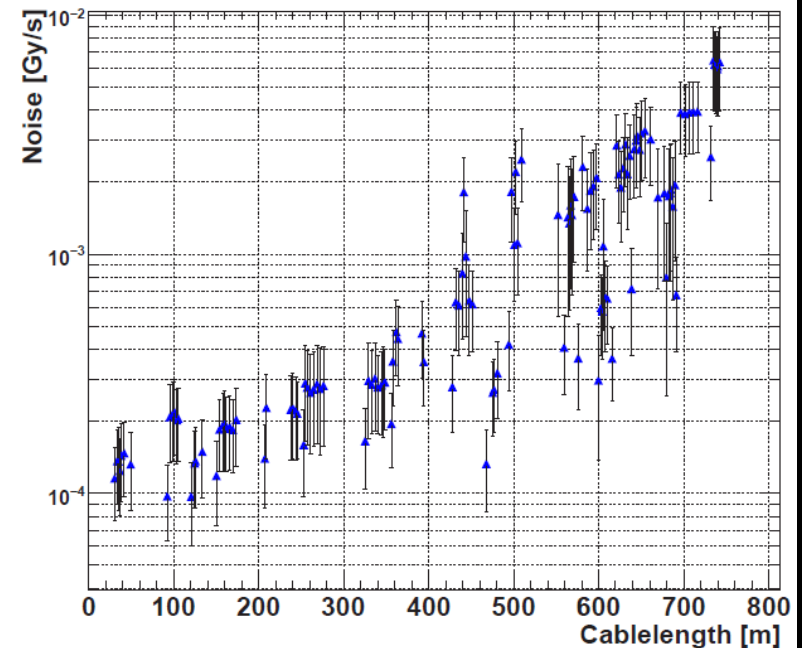

Threshold Management

- Beam abort thresholds
 - 12 integration intervals
 - from 40 μ s to 84s
 - 32 energy levels
 - Managed by family
- Each monitor will abort beam if:
 - One of the 12 integration intervals is over threshold
 - Internal test fails

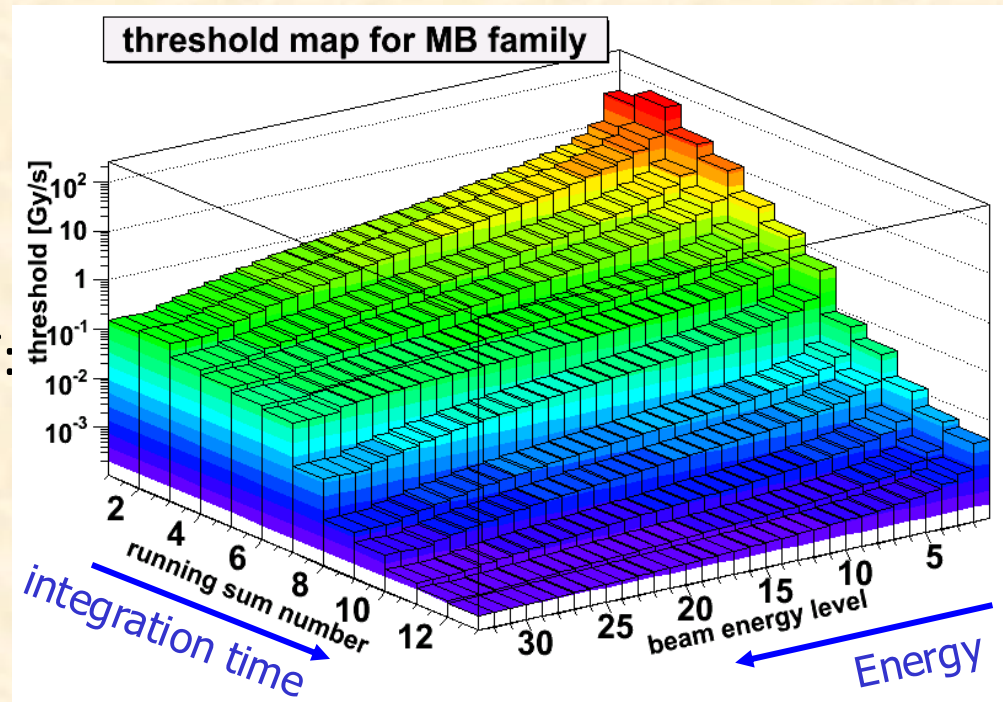

BLM Functionality – Collimator Verification

- BLM system used both for setting-up and qualifying
- Beam cleaning efficiencies $\geq 99.98\%$ ~ as designed

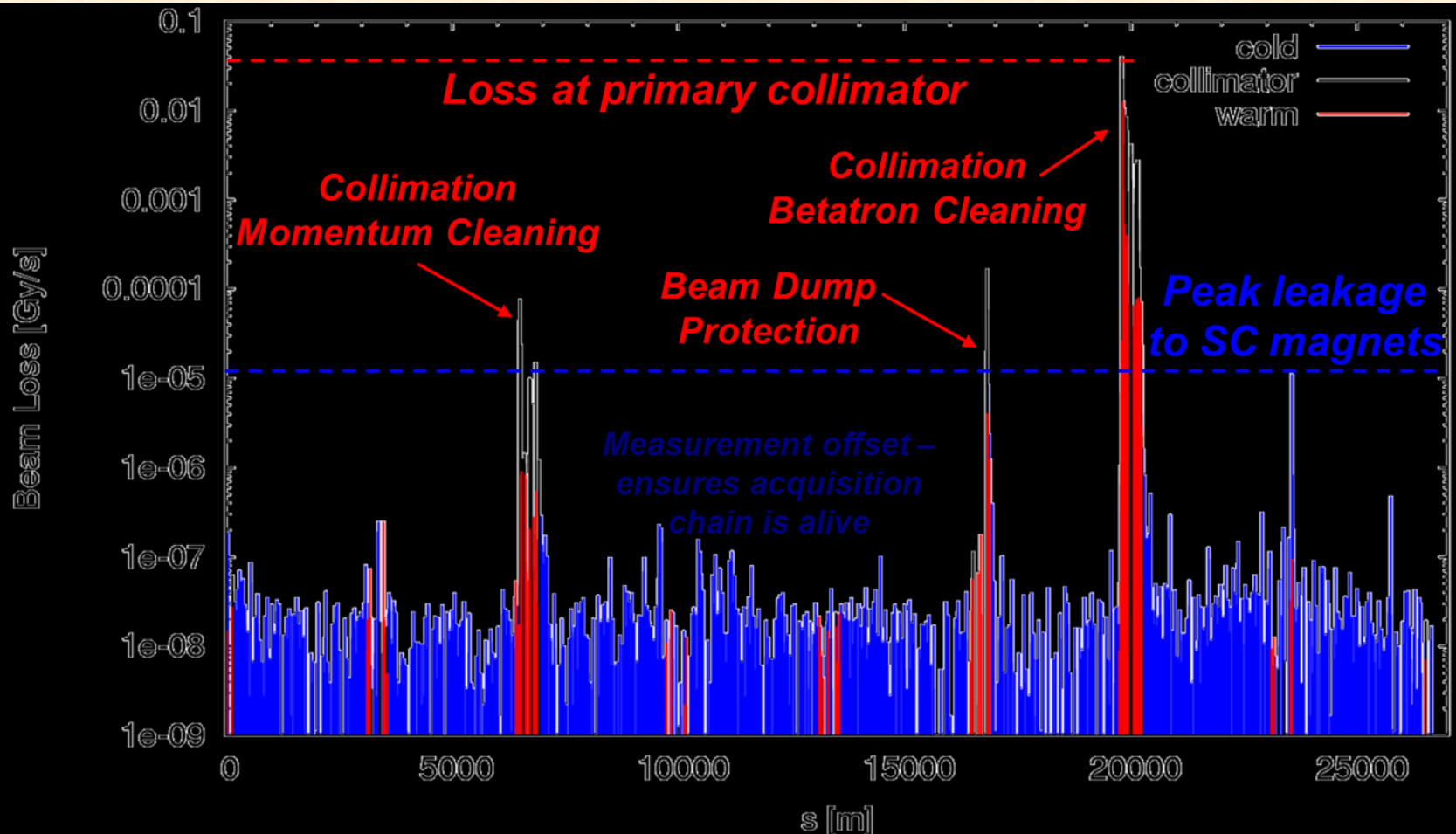

Observing Fast Losses

- Dealing with Unidentified Falling Objects (UFOs)
- In 2012:
 - 20 beam dumps due to (Un)identified Falling Objects
 - 14 dumps at 4TeV, 3 during ramp, 3 at 450GeV
 - ~17,000 candidate UFOs below BLM thresholds
- At 6.5 – 7 TeV
 - Quench thresholds much lower hence many more dumps expected

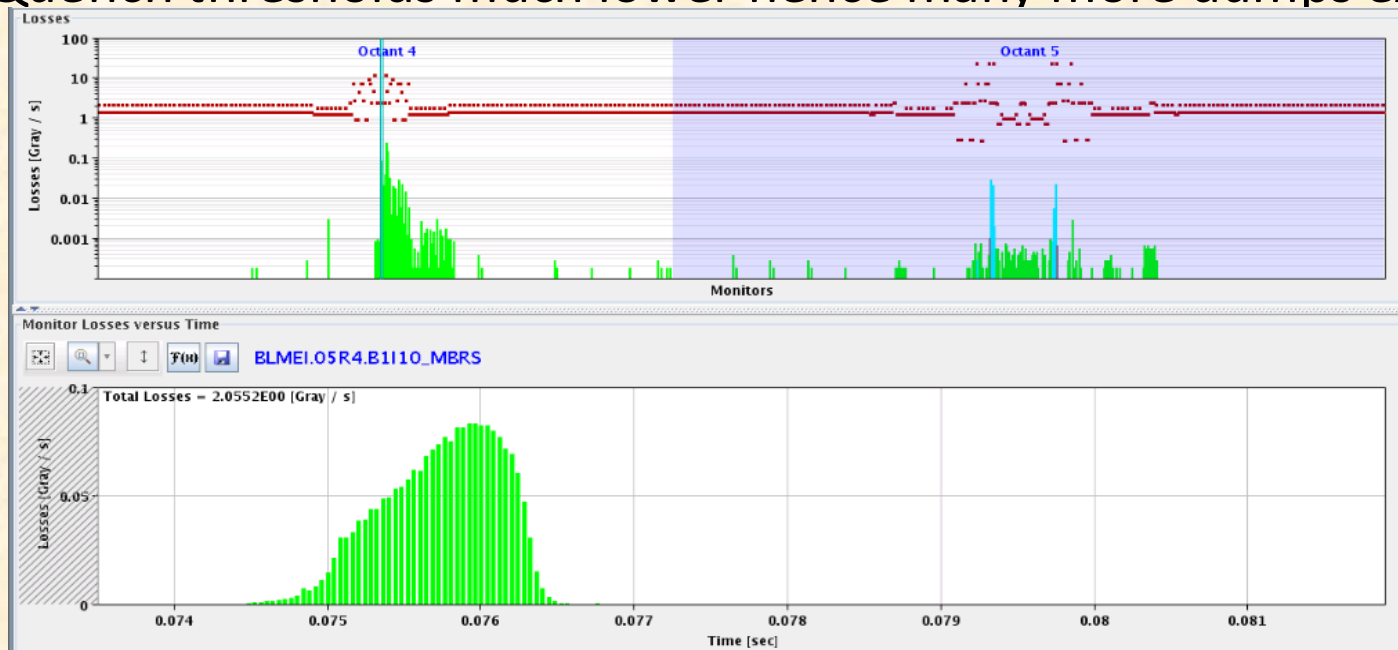
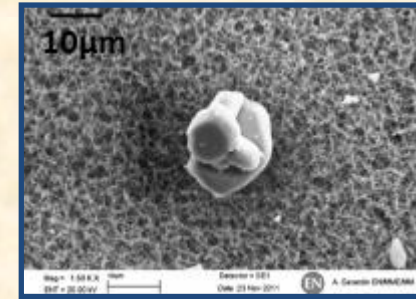

Observing Fast Losses

- Diamond Detectors
 - Fast & sensitive
 - Used in LHC to distinguish bunch by bunch losses

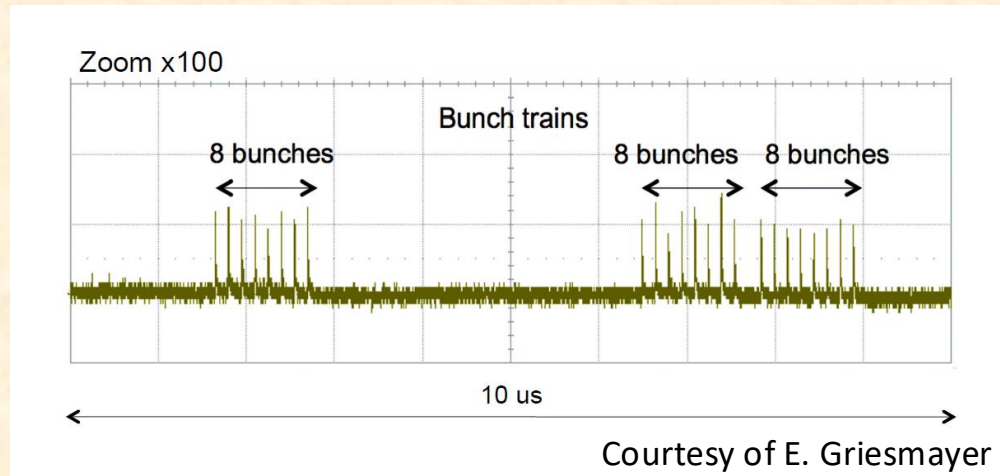
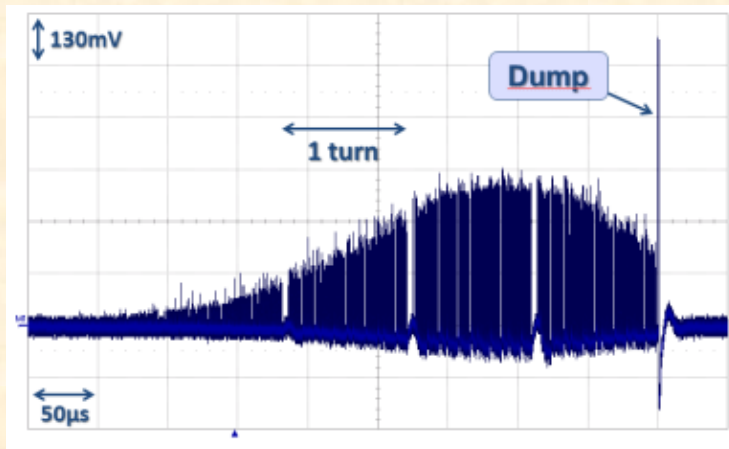
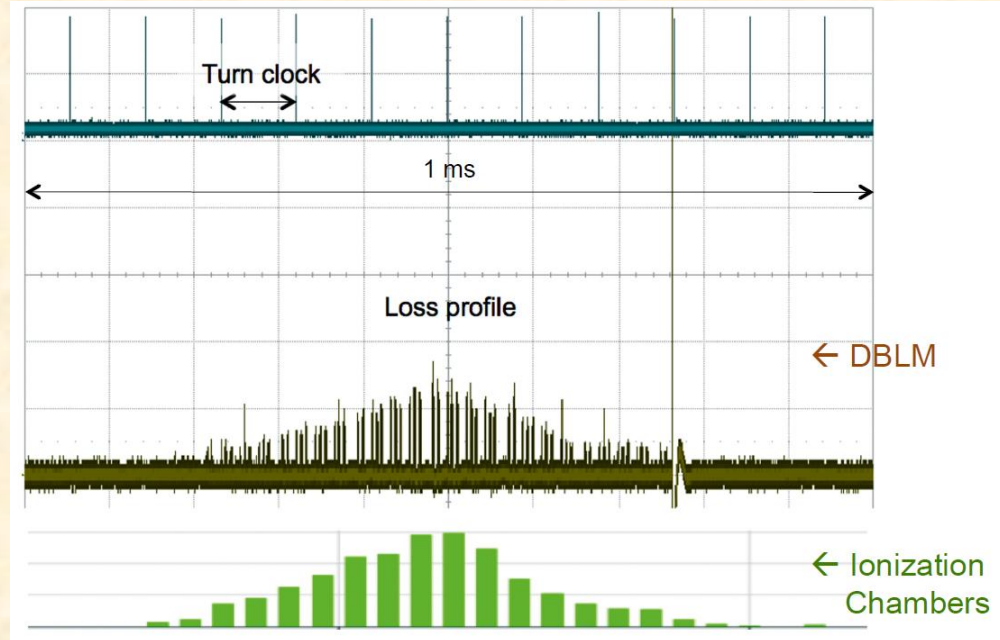
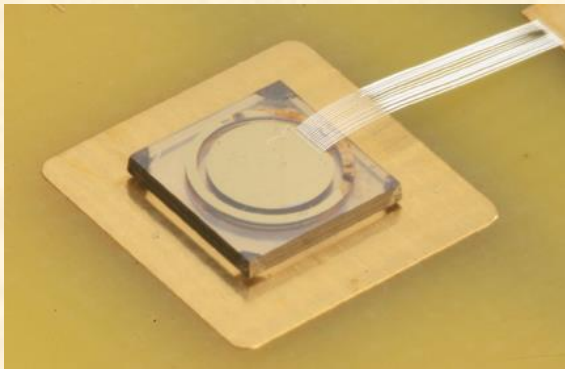



Accidental beam loss

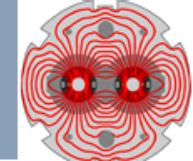

YEARS/ANS CERN

Unit: Gray/s Scale: Log Integration Time: 40 us Start 1900 End 2047 Losses: Max Display: Acquisition

rs Filter Octant Filter Dump Filter List Filter Regex Filter Beam Permit Filter

3550 / 3892

Monitor	40 us	80 us	320 us	640 us	2560 us	10 ms	82 ms	655 ms	1.3 s	5.2 s	20.9 s	83.8 s
L31L8.B1E10_MQ	Dump	Dump	Dump	Dump	Dump	Dump	Ok	Ok	Ok	Ok	Ok	Ok
L04L6.B1E10_TCDSA.4L6.B1	Dump	Dump	Dump	Dump	Dump	Dump	Dump	Ok	Ok	Ok	Ok	Ok
L04L6.B1E10_TCDSB.4L6.B1	Dump	Dump	Ok	Ok	Ok	Ok	Ok	Ok	Ok	Ok	Ok	Ok
L04L6.B2110_TCDOA.04L6.B2	Dump	Dump	Dump	Dump	Dump	Dump	Ok	Ok	Ok	Ok	Ok	Ok
L04R6.B2110_TCDSB.4R6.B2	Dump	Dump	Ok	Ok	Ok	Ok	Ok	Ok	Ok	Ok	Ok	Ok
L04R6.B2110_TCDSA.4R6.B2	Dump	Dump	Dump	Dump	Dump	Dump	Dump	Ok	Ok	Ok	Ok	Ok
L04R6.B1E10_TCDOA.B1R6.B1	Dump	Dump	Dump	Dump	Dump	Dump	Ok	Ok	Ok	Ok	Ok	Ok

Type: IC LIC SEM

Section: LSS DS ARC

Left Right: Left Right

Octant: 1 2 3 4

Beam: Beam 1 Beam 2

ump Indicators



30.07.2011 23:53:11

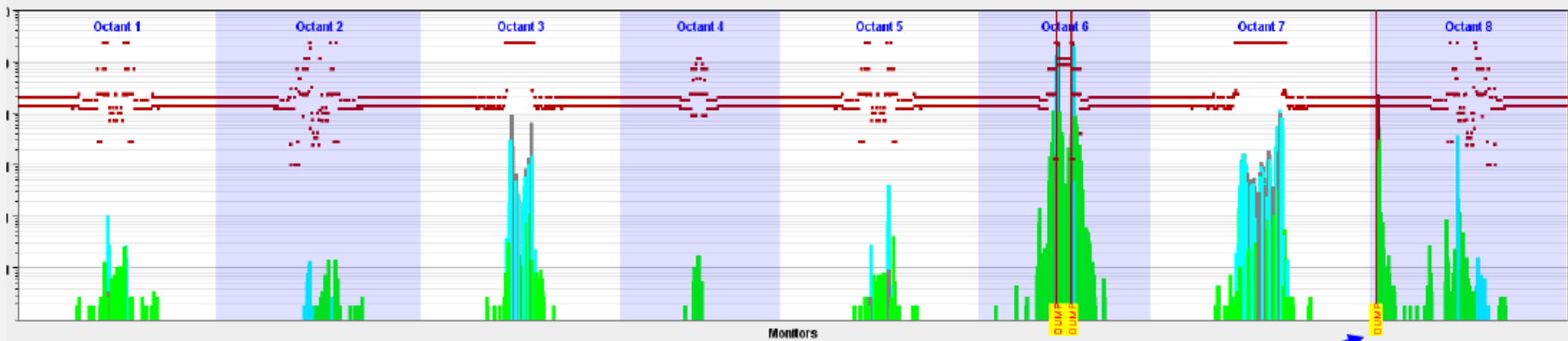

Losses versus Time

BLMQI.31L8.B1E10_MQ

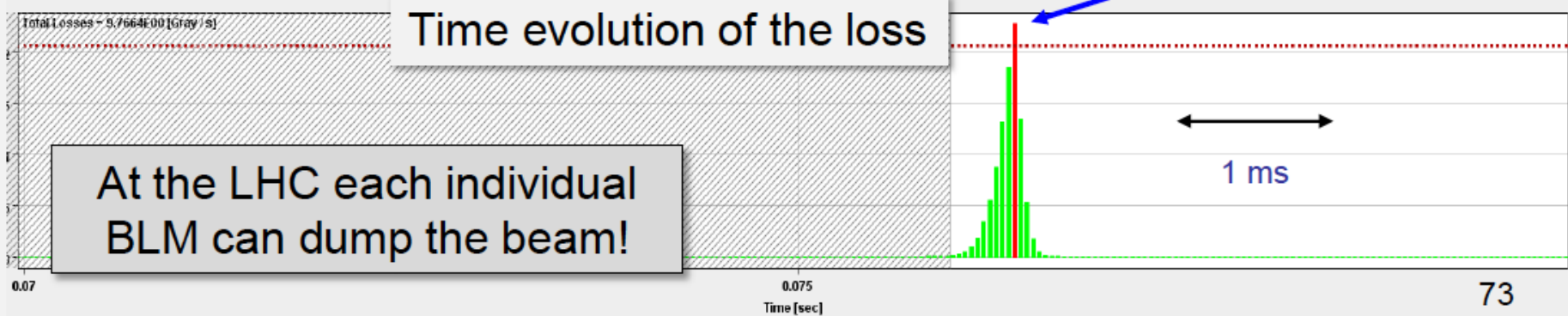

Time evolution of the loss

At the LHC each individual BLM can dump the beam!

November 2014 JAS - MPS and operation / LHC - J. Wenninger

Surprise, surprise !



- Very fast beam loss events (\sim ms) mainly in superconducting regions have been **THE SURPRISE** of LHC operation – nicknamed UFOs*.
 - *\sim 20 dumps by such UFO-type events every year (2010-2012).*
- The signals are consistent with small (10's μ m diameter) dust particles 'entering' the beam.

Time evolution of a UFO-type loss

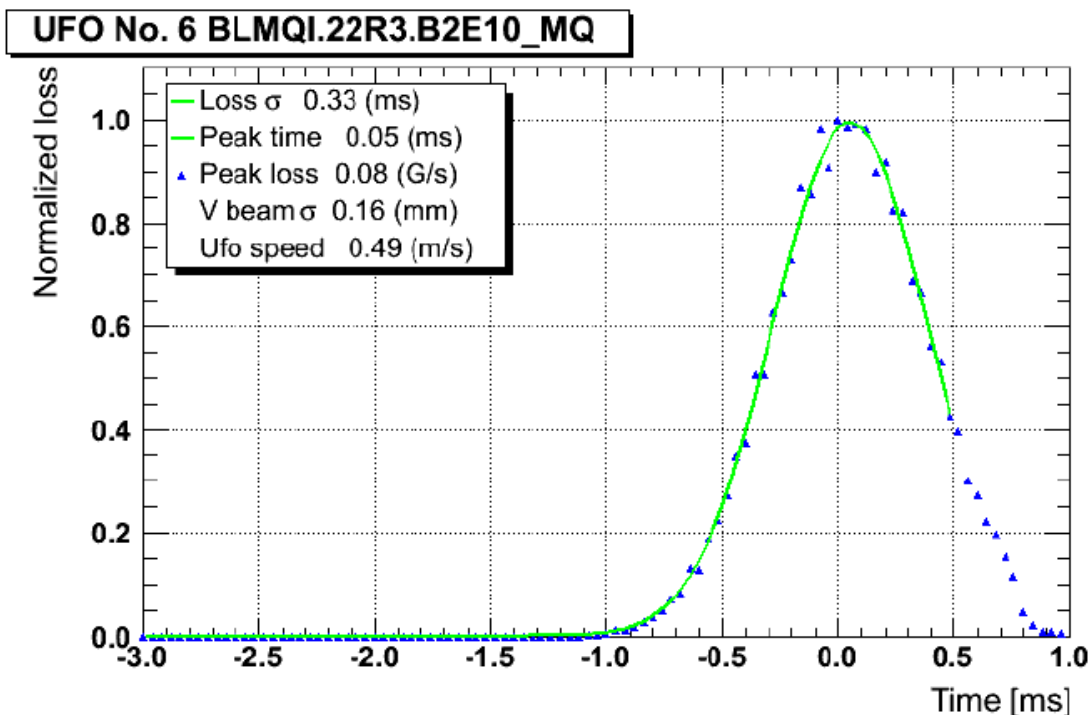

*:Unidentified Falling Object, acronym borrowed from nuclear fusion community

UFO monitoring



- Monitoring of UFO-like loss events was initiated. *The vast majority of events lead to losses below dump threshold.*
- For LHC injection kickers UFOs could be traced to Al oxide dust → cleaning campaign during the long shutdown.
- There is **conditioning** with beam:
 - The (non-dumping) UFO-rate drops from ~10/hour to ~2/hour over a year.

In the injection kickers UFOs were traced to Al oxide particles.

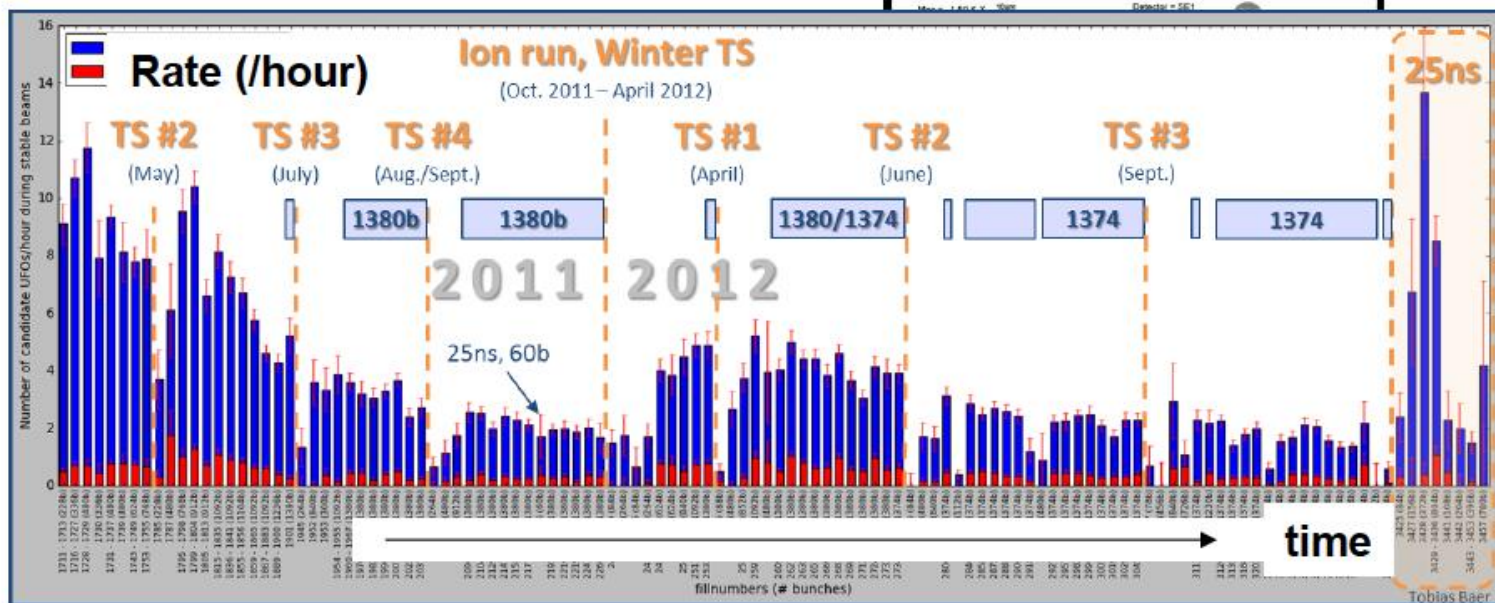
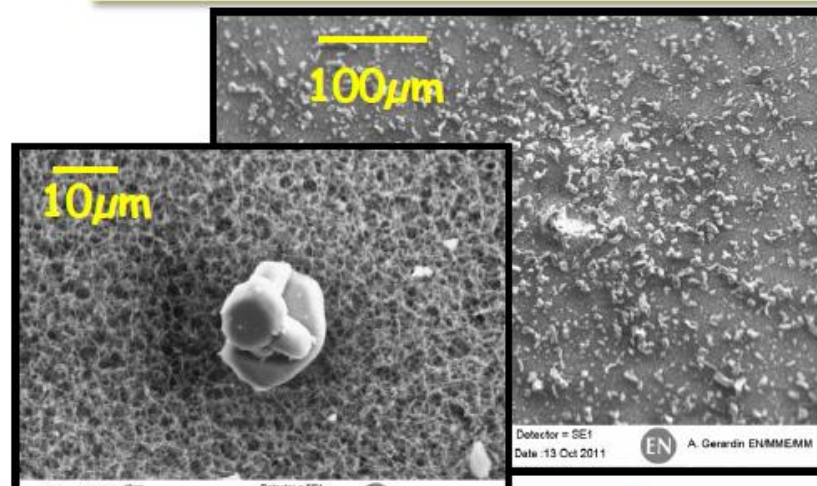

Beam induced RF heating?

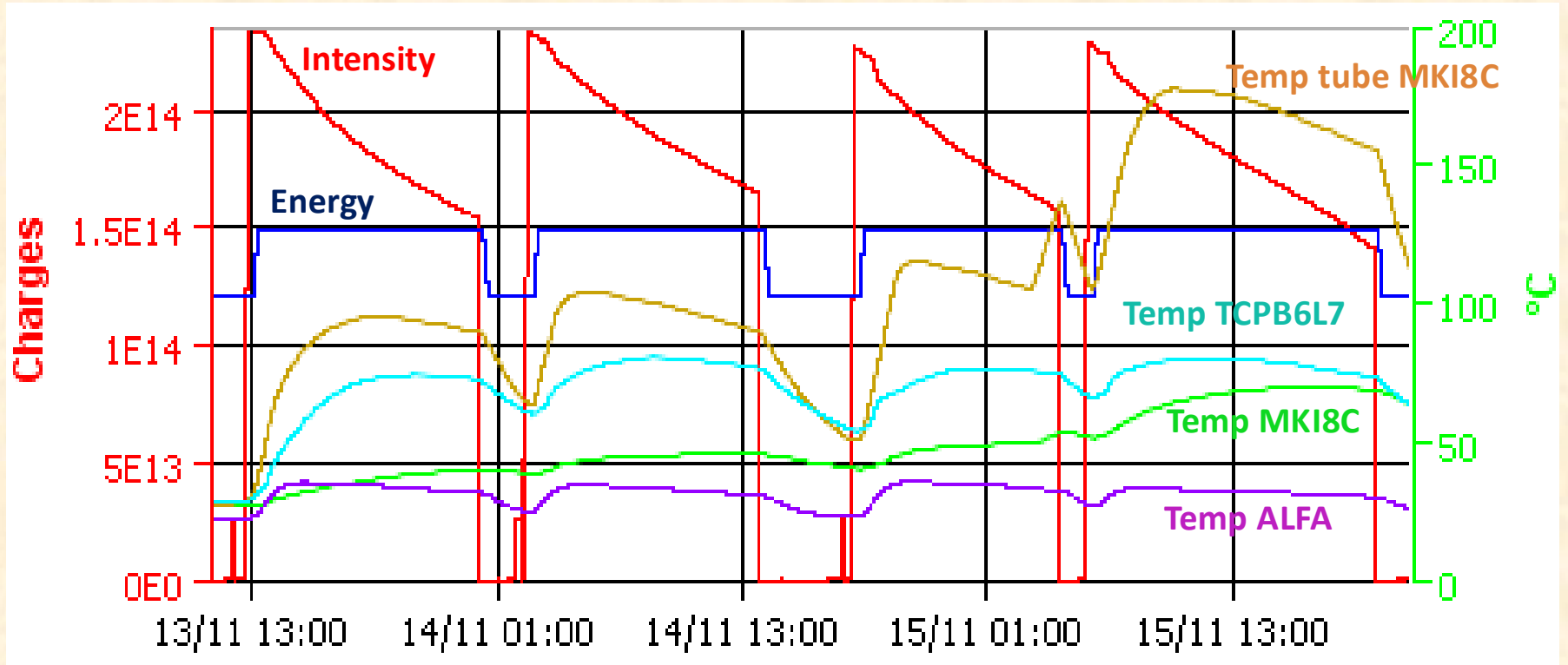

- Example of temperature increase for kicker, collimator, detector during 4 LHC fills in mid Nov 2012
- Temperature increase believed to be due to the interaction of beam induced wake fields with the surrounding → also referred to as “RF heating”
- Temperature increase in LHC devices can cause several issues (damage, delays, dumps)
- Other sources of heating of beam surrounding : synchrotron light, beam losses, electron cloud (not addressed during this talk)

18 typical LHC days

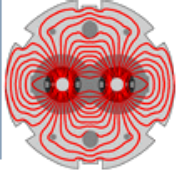

Timeseries Chart between 2012-10-22 19:15:00.000 and 2012-11-08 20:20:11.330 (UTC_TIME) Timescaled with AVG every 1 MINUTE

LHC.BE1C.A094.B1.BEAM_INTENSITY LHC.BE1D.C.A094.B2.BEAM_INTENSITY

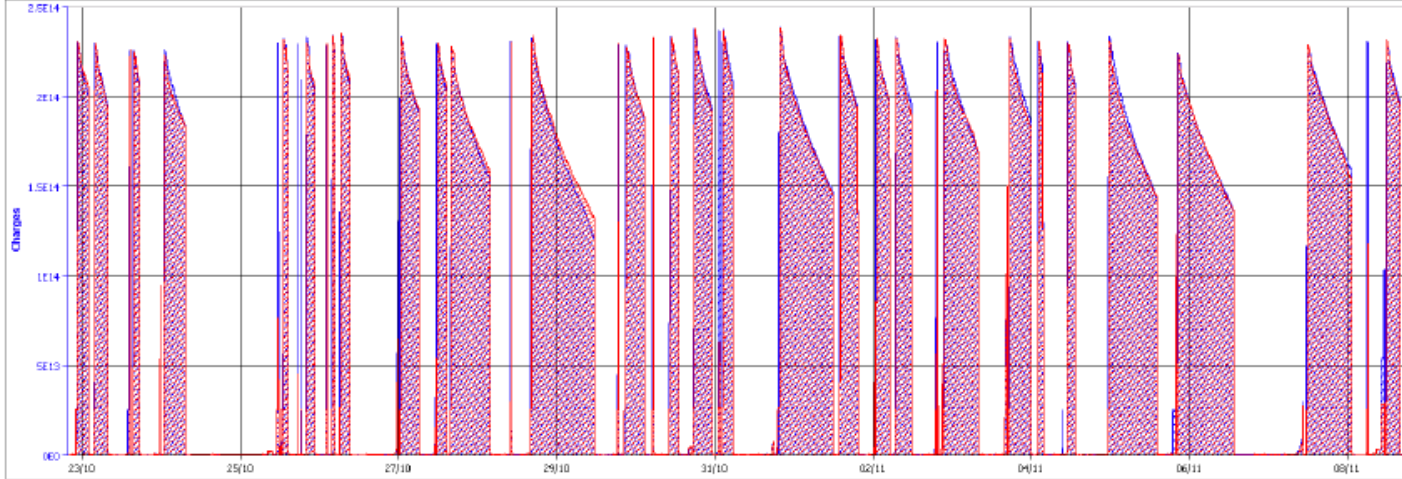

Intensity B1

Intensity B2

Timeseries Chart between 2012-10-22 19:15:00.000 and 2012-11-08 20:20:11.330 (UTC_TIME) Timescaled with AVG every 1 MINUTE

ATLAS.LUM_TOT_RST LHC.BSRA.US06.B1.ABORT_GAP_ENERGY

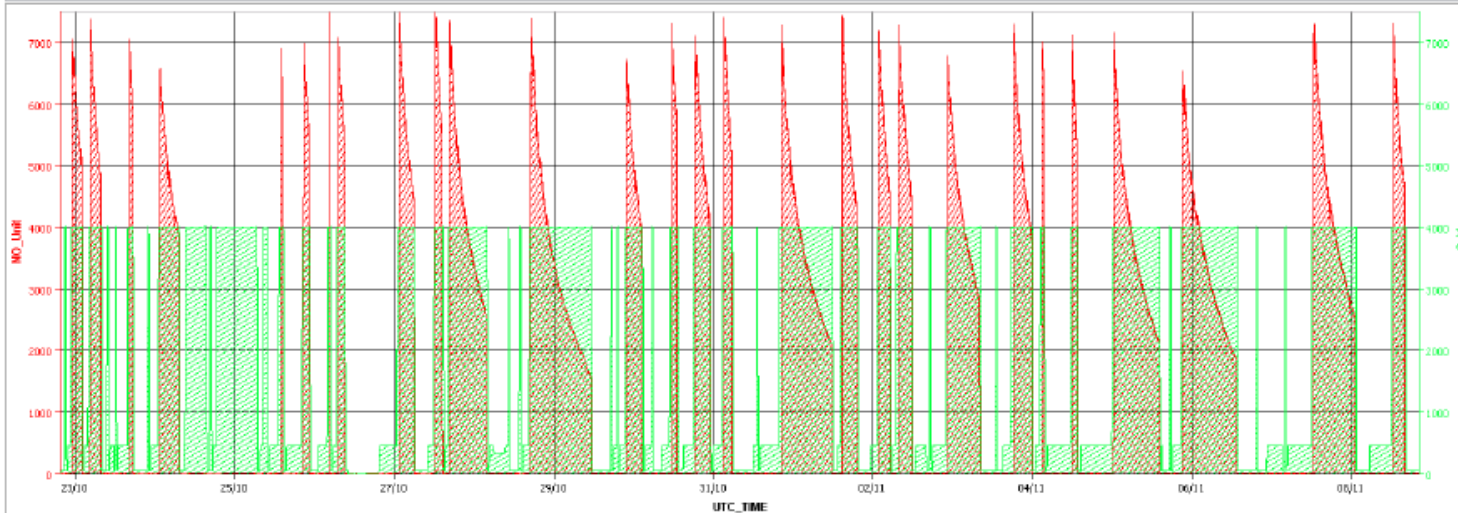

Luminosity

Energy

*Luminosity
lifetime ~ 10 h*

Summary

- The LHC is a very complex machine.
- The energy stored in the LHC could destroy it in a single turn.
- Its operation must balance availability for HEP and safety.
- All known effects had been correctly anticipated however some unexpected phenomena were discovered.

THE JOURNEY OF A PROTON FROM THE SOURCE TO THE LHC

(Courtesy of D.Manglunki - BE/OP/CERN)

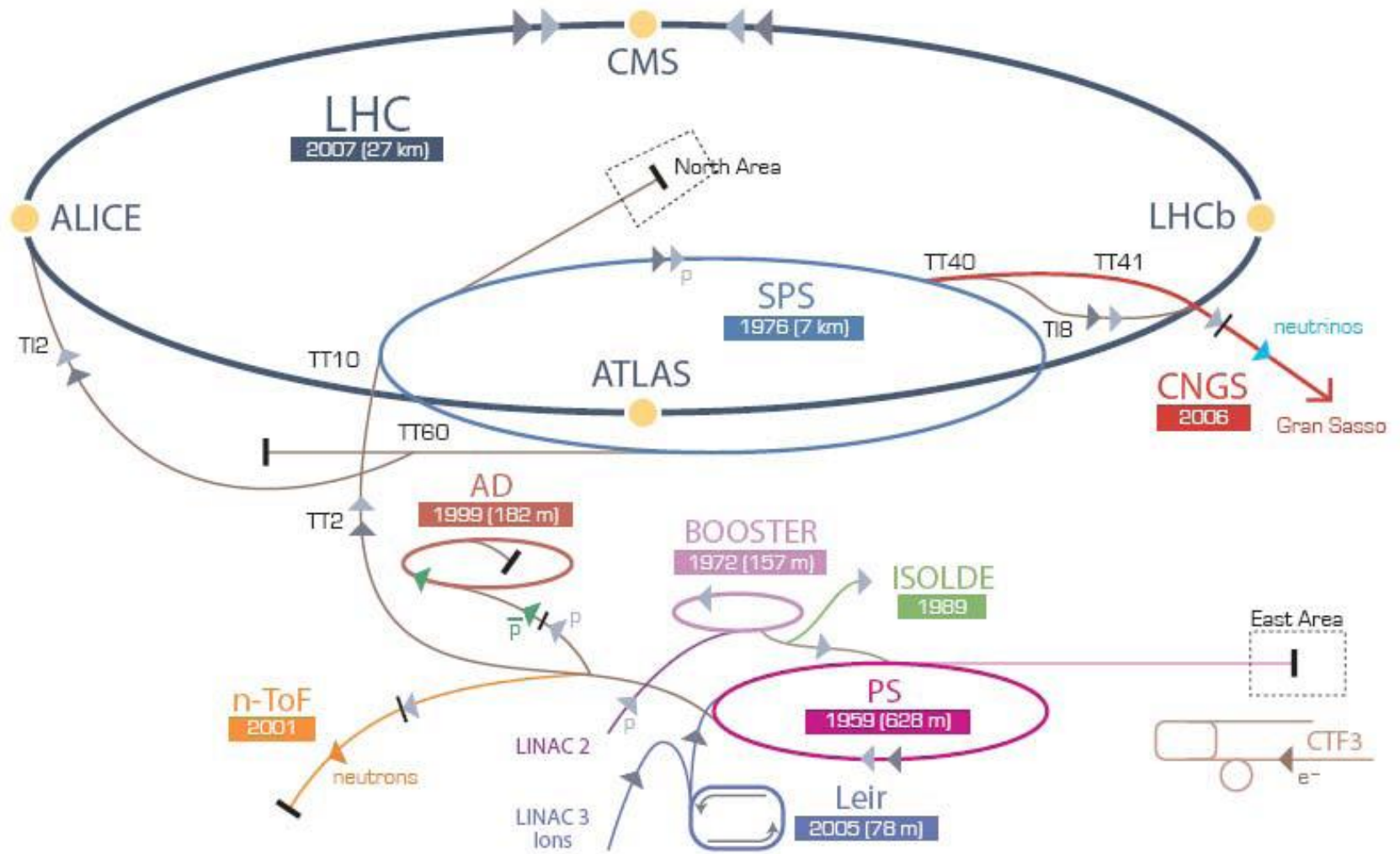

▶ p [proton] ▶ ion ▶ neutrons ▶ \bar{p} [antiproton] \leftrightarrow proton/antiproton conversion ▶ neutrinos ▶ electron

LHC Large Hadron Collider SPS Super Proton Synchrotron PS Proton Synchrotron

AD Antiproton Decelerator CTF3 Clic Test Facility CNGS Cern Neutrinos to Gran Sasso ISOLDE Isotope Separator OnLine DEvice

LEIR Low Energy Ion Ring LINAC LINear ACcelerator n-ToF Neutrons Time Of Flight

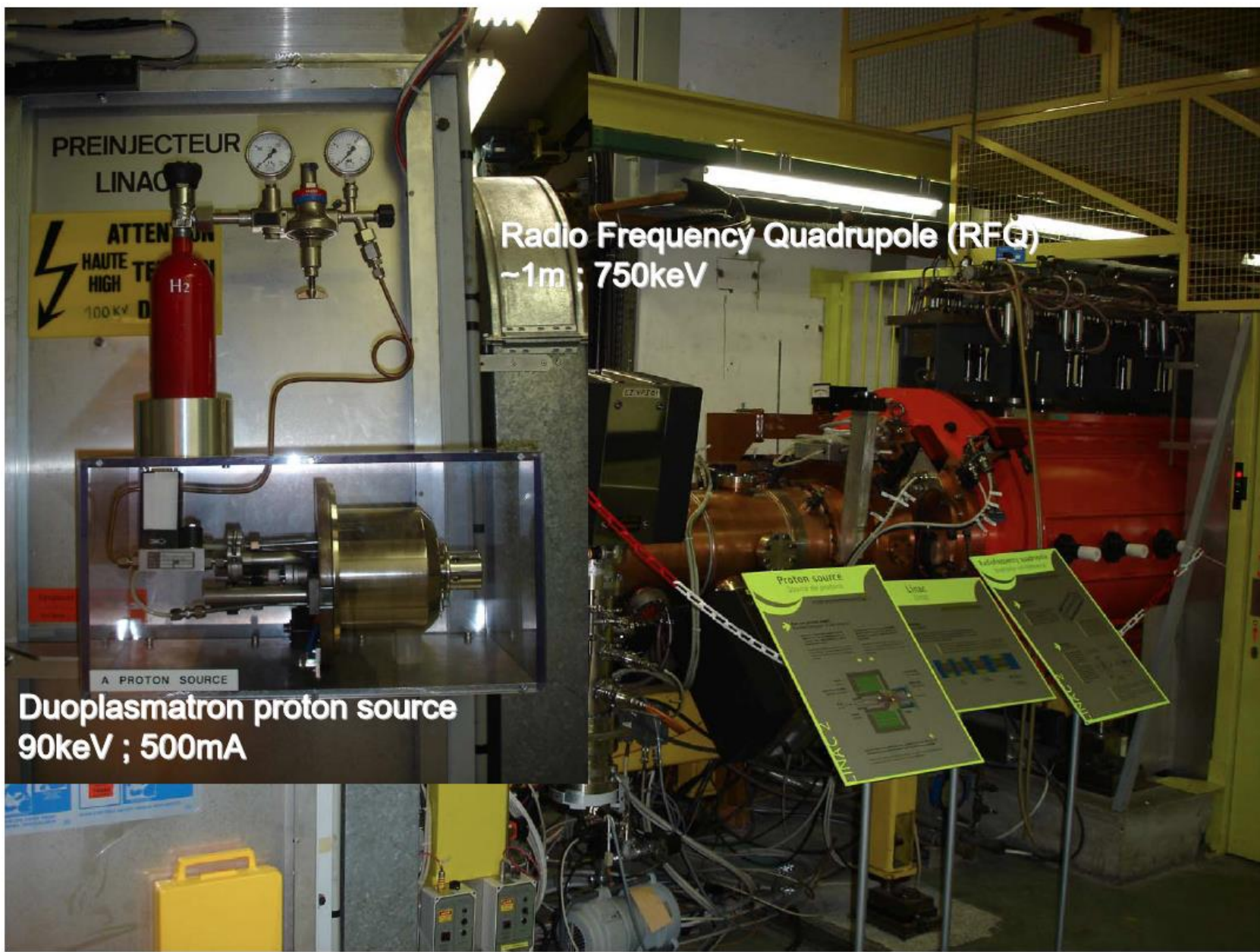

PREINJECTEUR
LINAC

ATTENTION
HAUTE TENSION
HIGH TENSION
100KV DANGER

H₂

A PROTON SOURCE

Duoplasmatron proton source
90keV ; 500mA

Radio Frequency Quadrupole (RFQ)
~1m ; 750keV

Proton source
Source de protons

Linac

Radio Frequency Quadrupole (RFQ)

LINAC 2

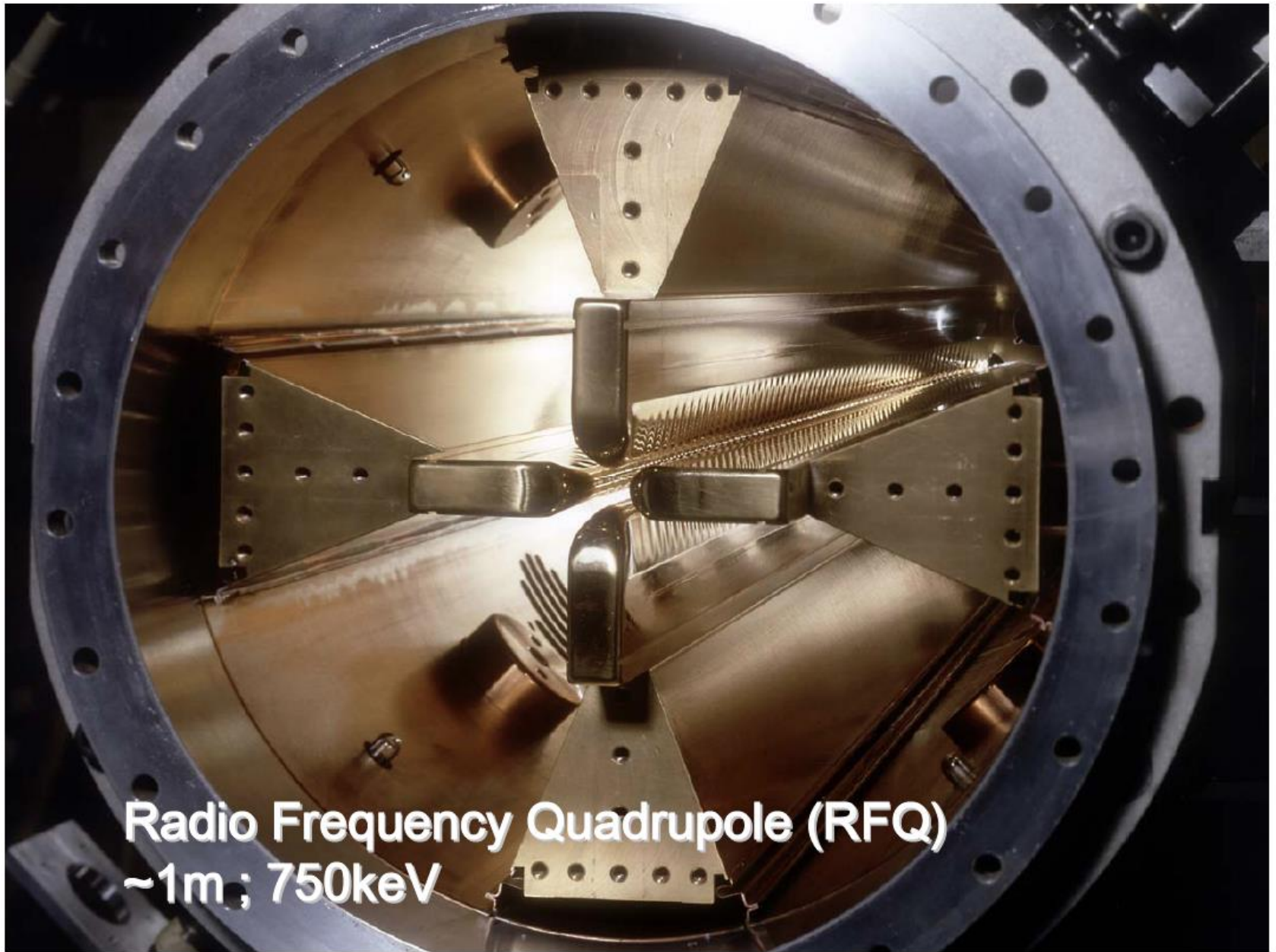

Radio Frequency Quadrupole (RFQ)
~1m ; 750keV

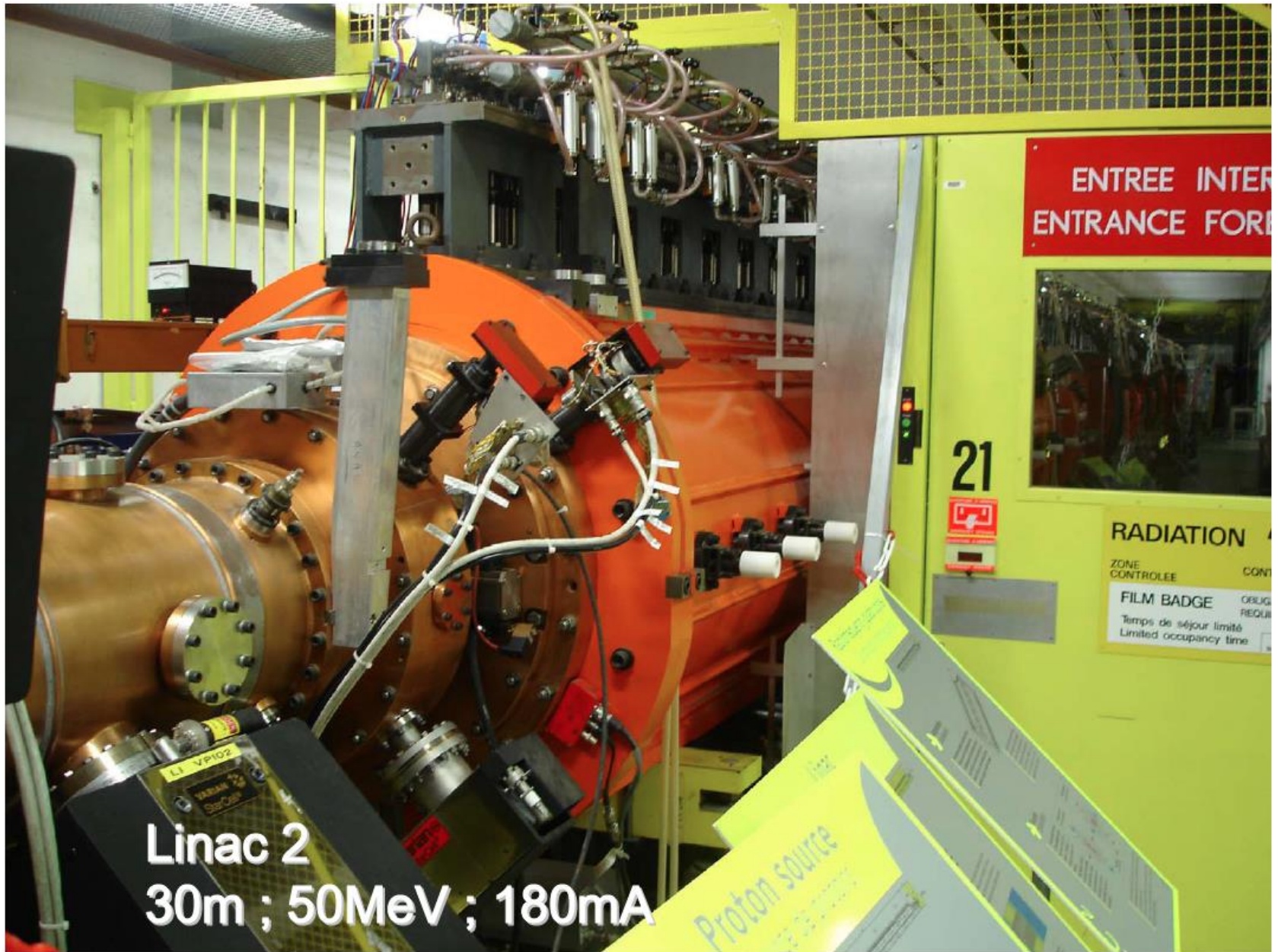

Linac 2
30m ; 50MeV ; 180mA

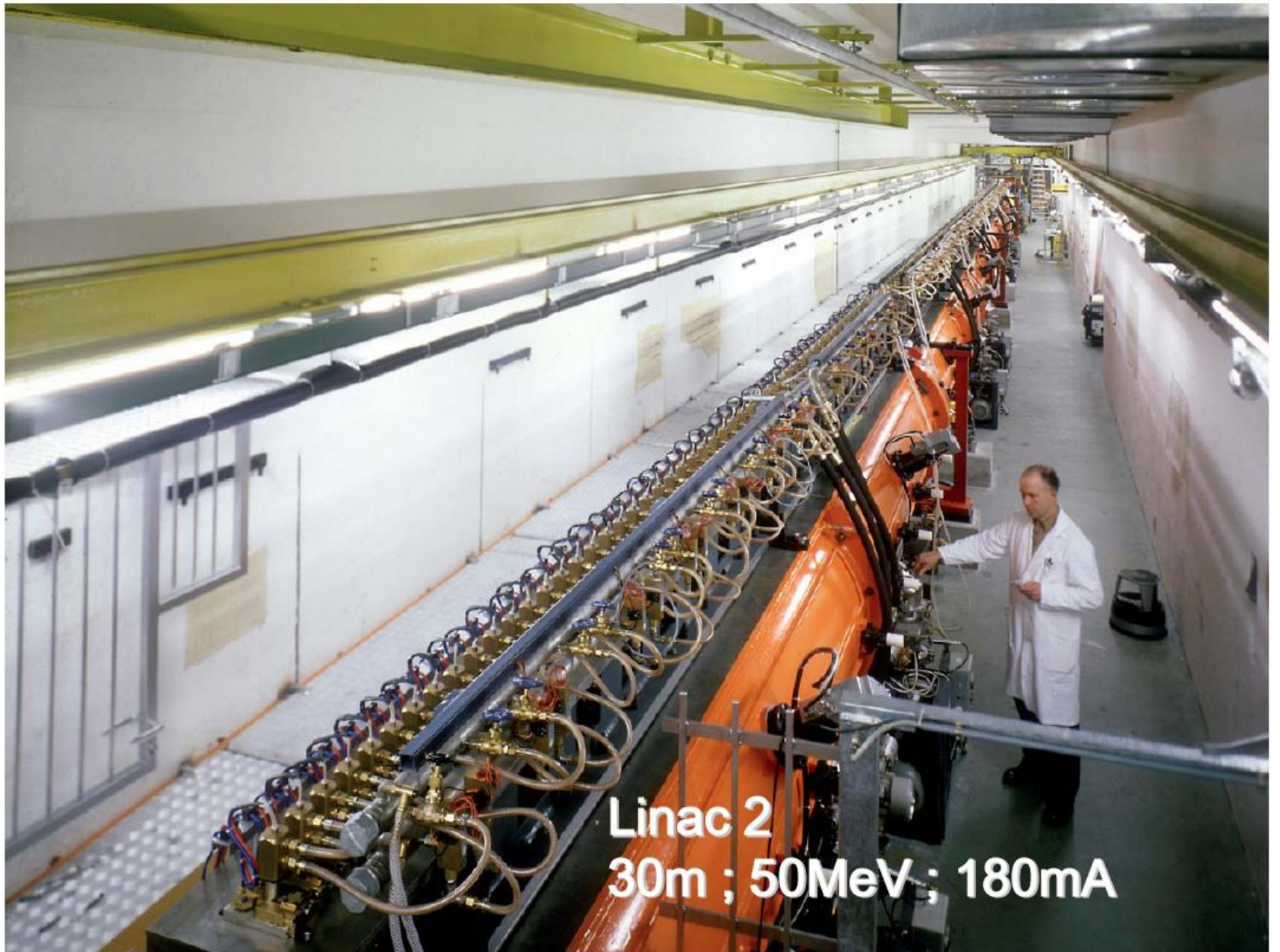

Linac 2
30m ; 50MeV ; 180mA



PSB distributor

Transfer line from Linac 2 to Proton Synchrotron Booster (PSB)



Proton Synchrotron Booster
4 rings ; 157m each
1.4GeV ; 10^{13} p⁺/ring

The photograph shows a long, industrial-style corridor with a blue carpet. On the right side, there are four parallel rows of large, green and orange metal cabinets, which are the four rings of the Proton Synchrotron Booster. Each ring is a long, narrow structure. In the foreground, there are several metal racks filled with electronic components and wiring. A yellow warning sign with a radiation symbol is placed on one of the racks. The ceiling is high and has a grid of fluorescent lights. The overall environment is a technical laboratory or control room for a particle accelerator.

⚠ DANGER
RADIATION ⚠
DO NOT TOUCH THIS EQUIPMENT
WHEN THE ACCELERATOR IS ON

Individual extraction lines
from each ring of the PSB

Extraction line from PSB to
Proton Synchrotron (PS)
& Isolde

Recombinations
1+2 & 3+4

Recombinations
(1-2) + (3-4)

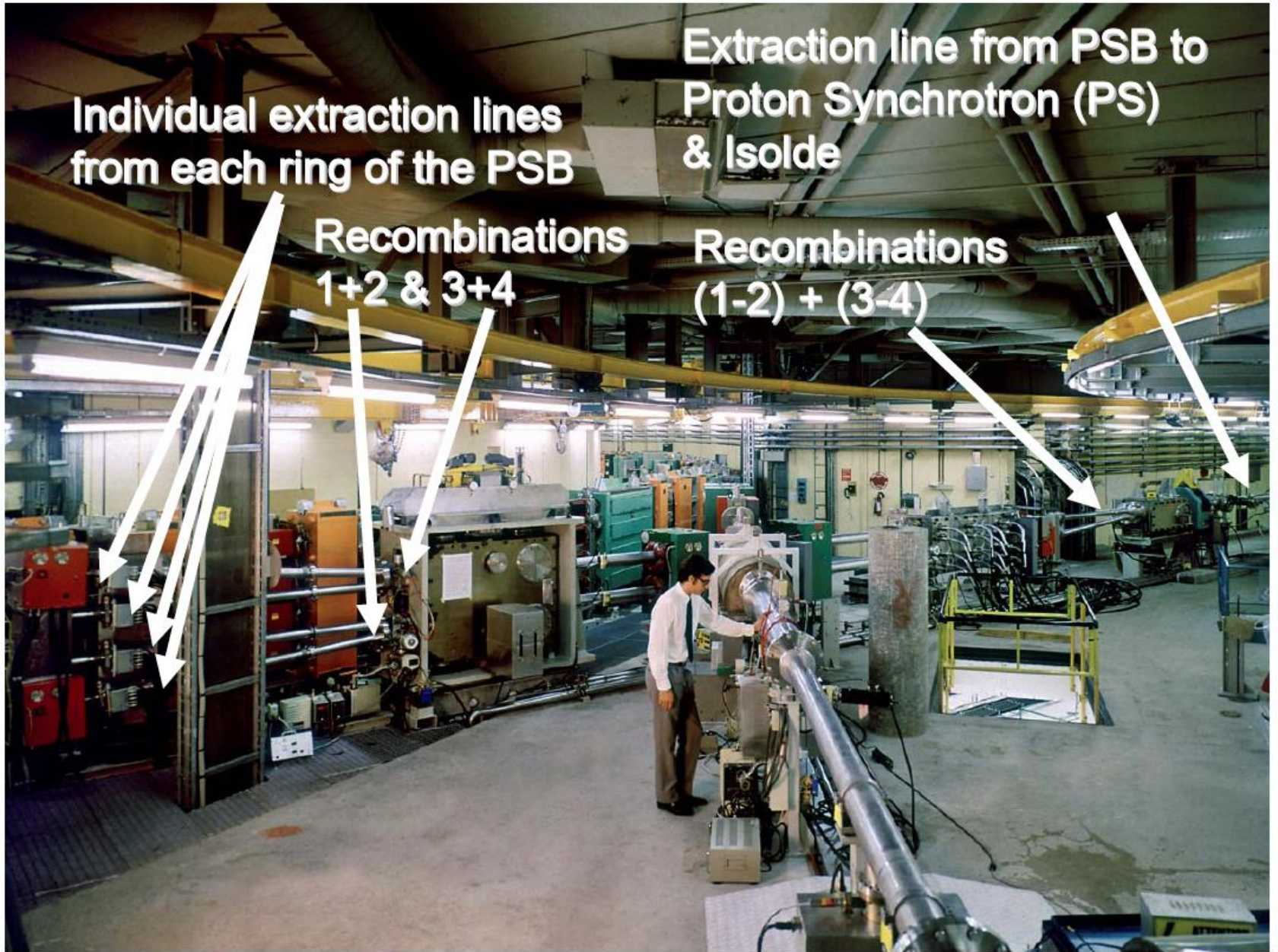

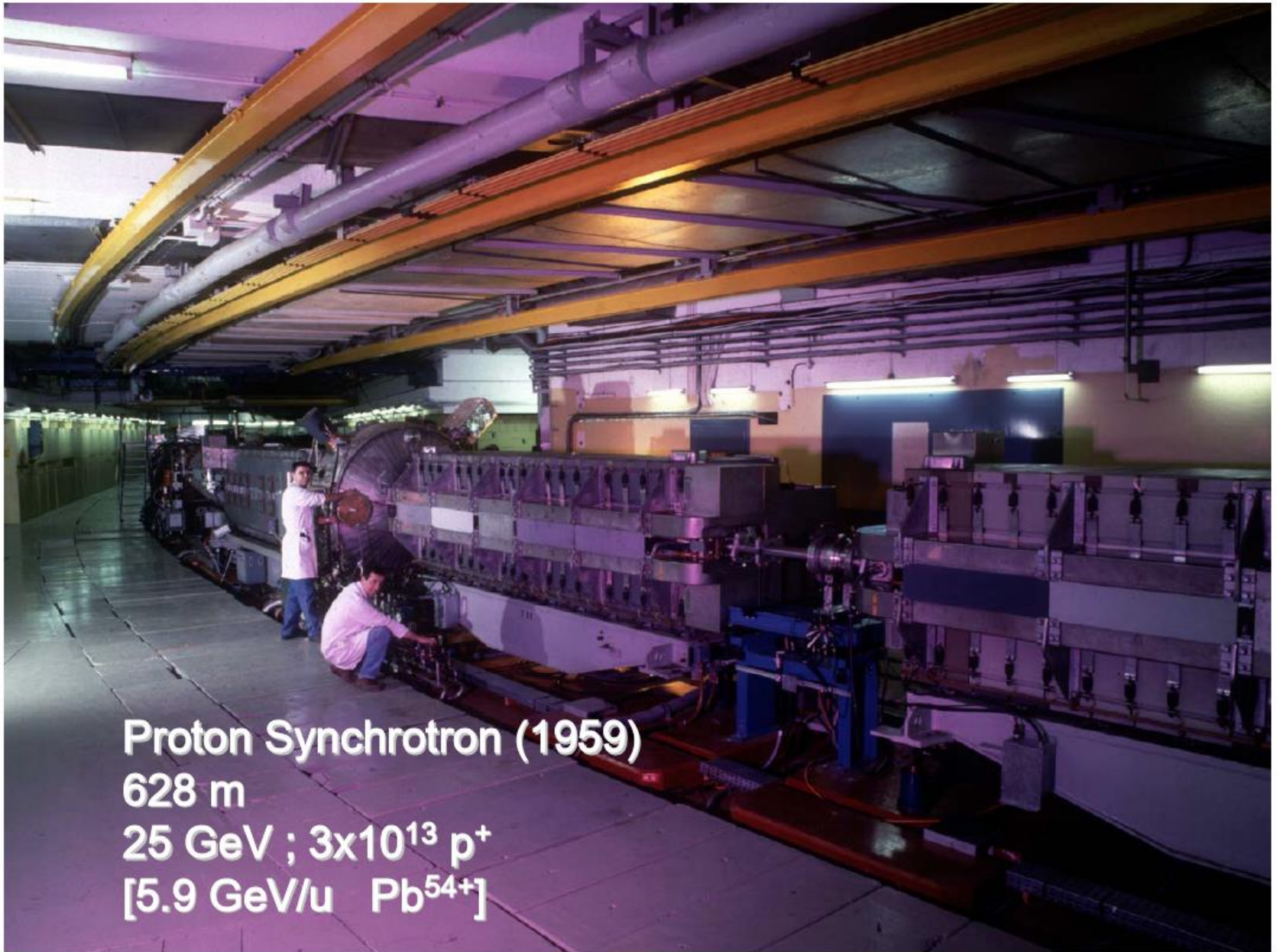

Proton Synchrotron (1959)

628 m

25 GeV ; 3×10^{13} p⁺

[5.9 GeV/u Pb⁵⁴⁺]

Super Proton Synchrotron (SPS)

6.9 km

450 GeV ; 5×10^{13} p^+

[177 GeV/u Pb^{82+}]

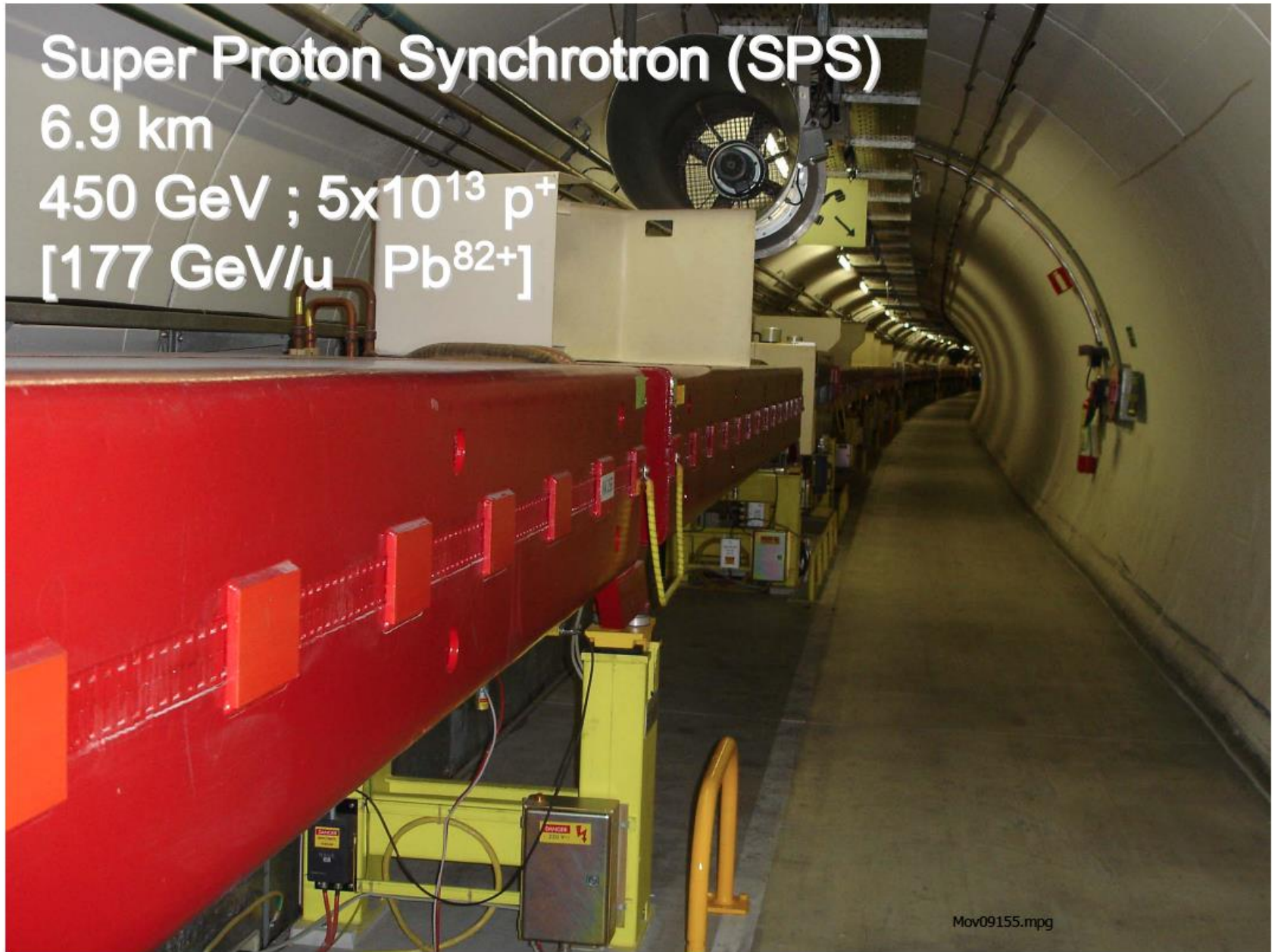



TI8 counter-clockwise transfer line from SPS to LHC

ATTENTION
EMPLACEMENT RESERVE
POUR LA POSE DES ANAITS

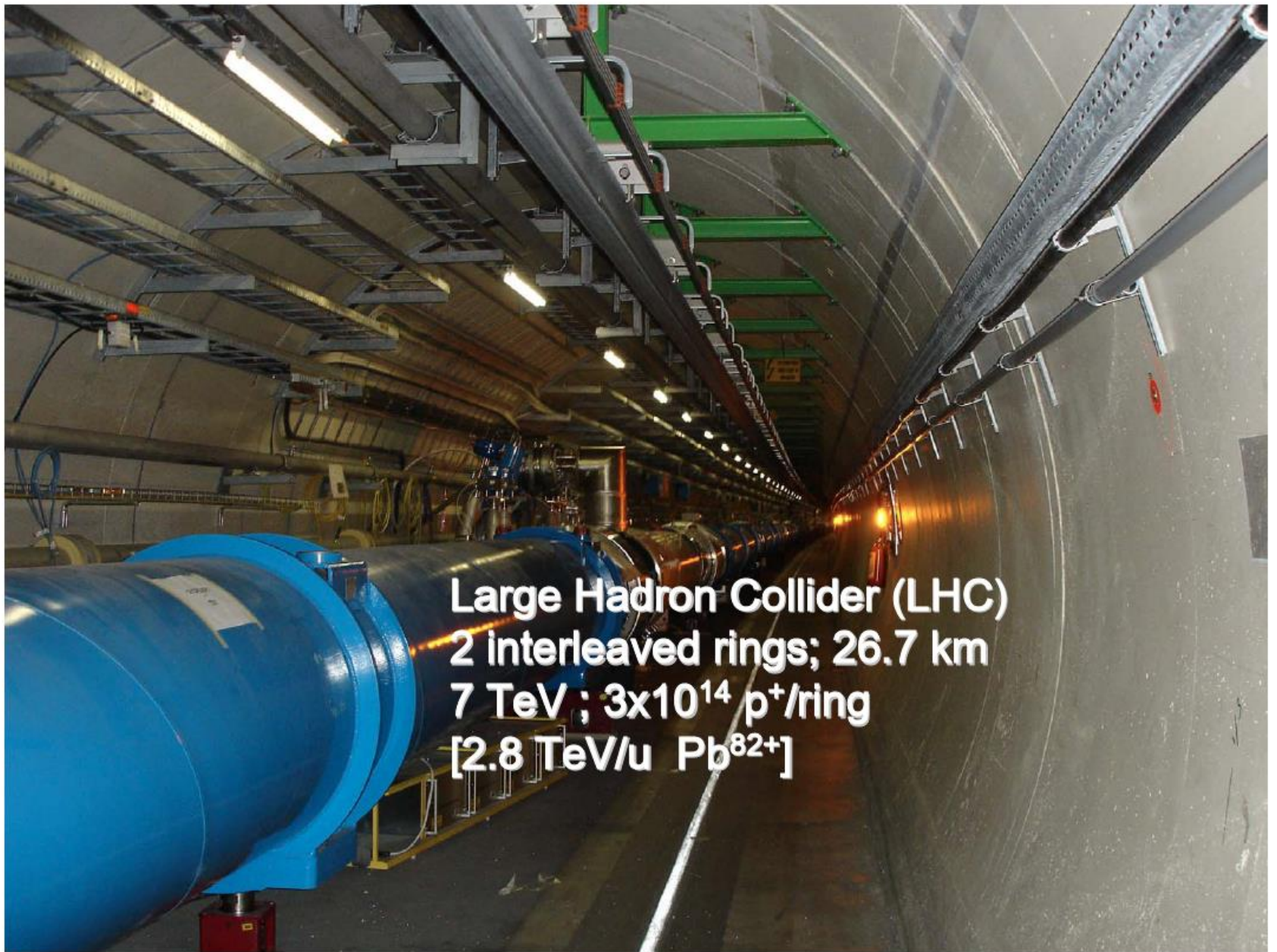

Large Hadron Collider (LHC)
2 interleaved rings; 26.7 km
7 TeV ; 3×10^{14} p⁺/ring
[2.8 TeV/u Pb⁸²⁺]