

ED PHENIICS

Understanding basic principles of particle accelerators

Machine-detectors interface and Applications of particle accelerators

Nicolas Delerue

IJCLab (CNRS and Université de Paris-Sud)

MACHINE DETECTOR INTERFACE

How easy is it to add an experiment on an accelerator?

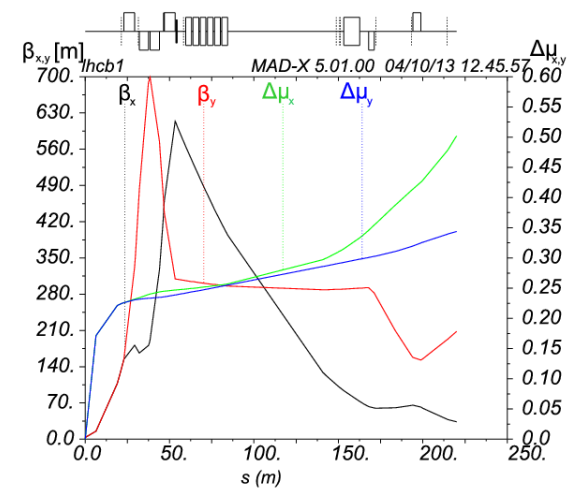
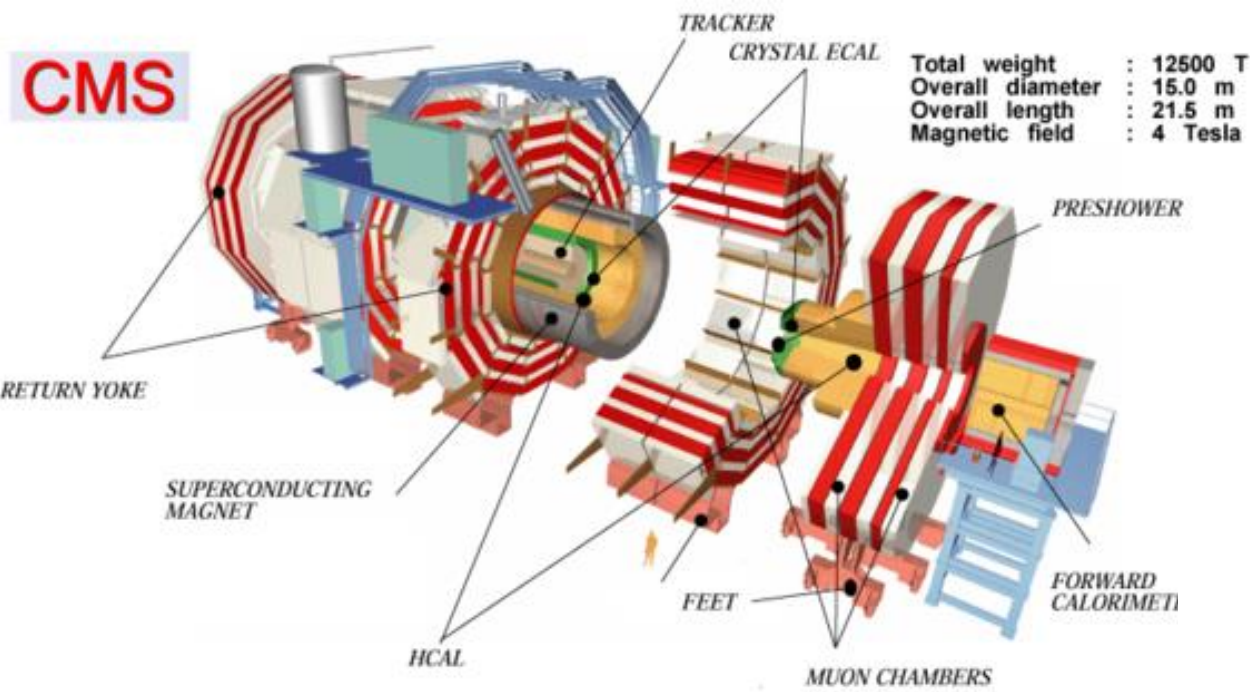

Adding a detector in an accelerator

- The detector is not transparent for the accelerator.
 - For example it often comes with limited apertures and a large magnet.
- The accelerator will also have side effects on the detector: for example by creating backgrounds and large RF fields.
- The interface between the detector and the machine need to be studied carefully.

Interaction point at the ILC

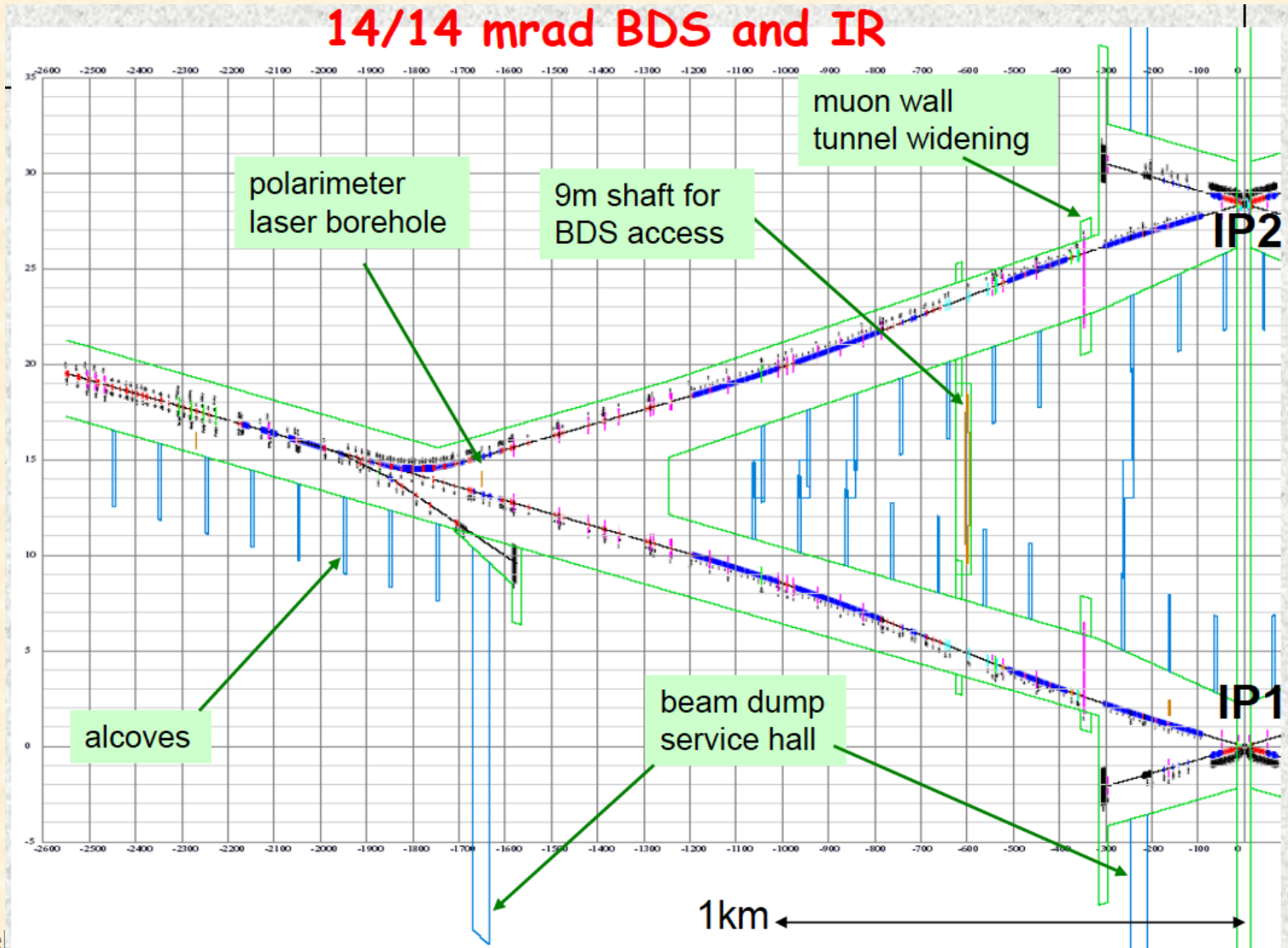

ILC MACHINE-DETECTOR INTERFACE

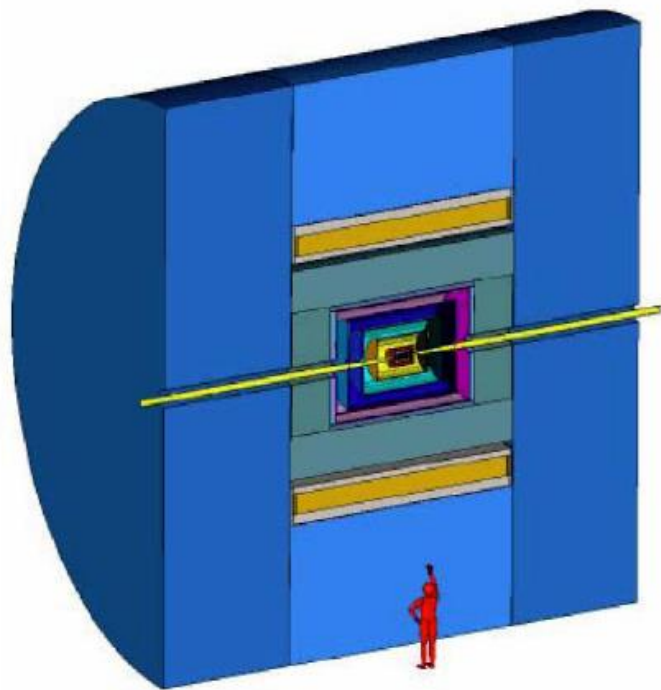

ILC "compact" detector SiD
with 5-Tesla solenoidal field

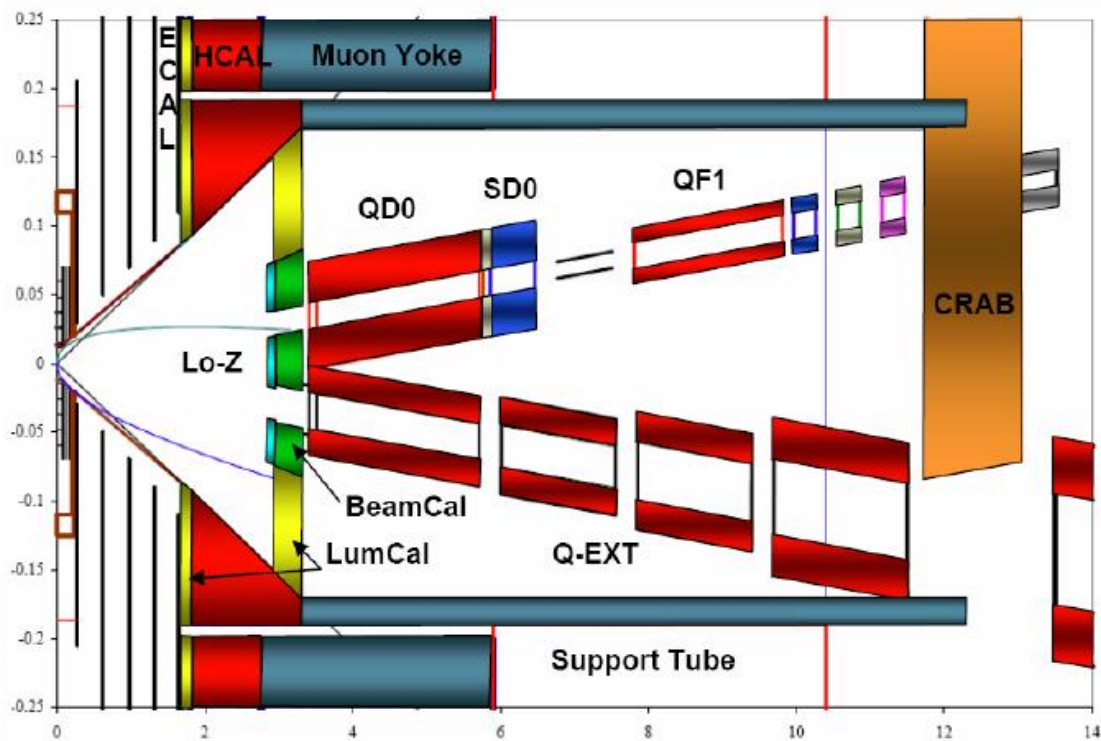

$L^* \approx 3.5$ m, compare to $L^* = 23$ m at LHC!

BACKGROUNDS AND DETECTOR PERFORMANCE

Two sources

1. IP backgrounds: Particles originated from the interaction point (IP) - beam-beam interaction products and collision remnants.
2. Machine backgrounds: Unavoidable bilateral irradiation by particle fluxes from the beamline components and accelerator tunnel.

Backgrounds affect ILC detector performance in three major ways:

- Detector component radiation aging and damage.
- Reconstruction of background objects (e.g., tracks) not related to products of e^+e^- collisions !!!
- Deterioration of detector resolution (e.g., jets energy resolution due to extra energy from background hits).

COLLIMATION SYSTEM AND MAGNETIC SPOILERS IN BDS

Collimation depth: $X = 9\sigma_x, Y = 6\sigma_y$
 Amplitude spoiler: $\beta_{x/y} = 600\text{m}/1000\text{m}$
 Momentum spoiler: Dispersion = 0.15 m

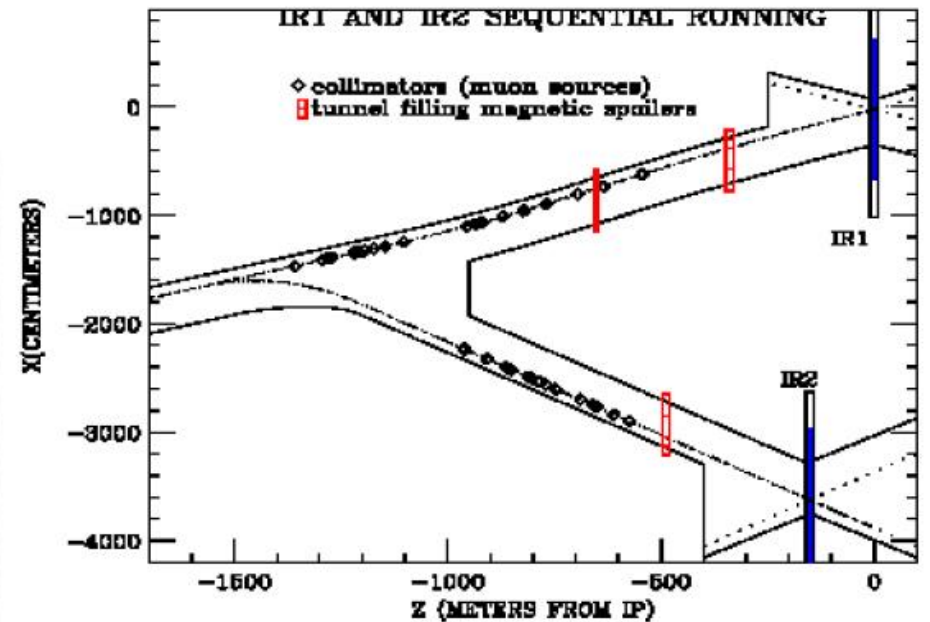
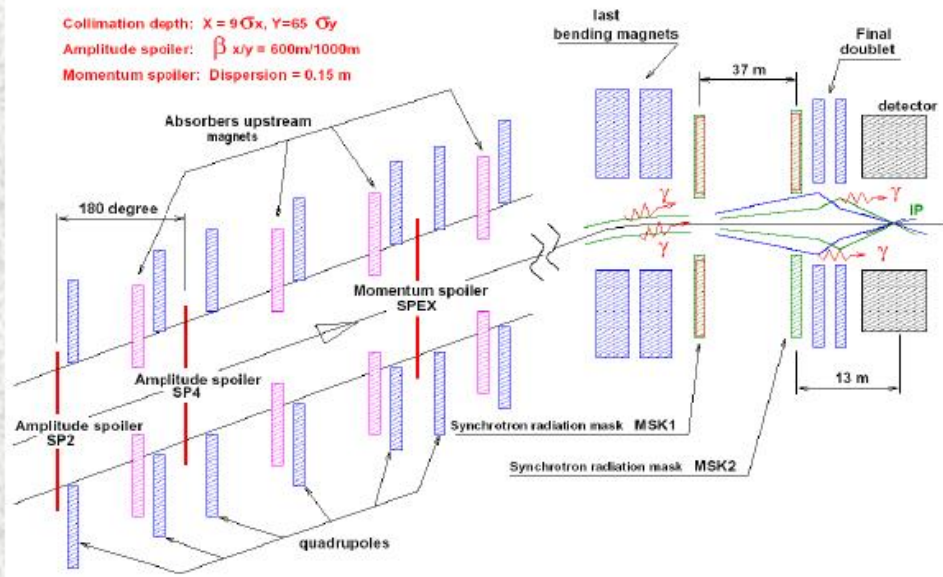

BEAMSTRAHLUNG

Beams are extremely collimated with large bunch charge
 → electrons of one bunch radiate against the coherent field of the other bunch

$$dE \sim \frac{N^2}{\sigma_x^2 \sigma_z}$$

→ average energy loss 1.5% for electrons/positrons at 500 GeV

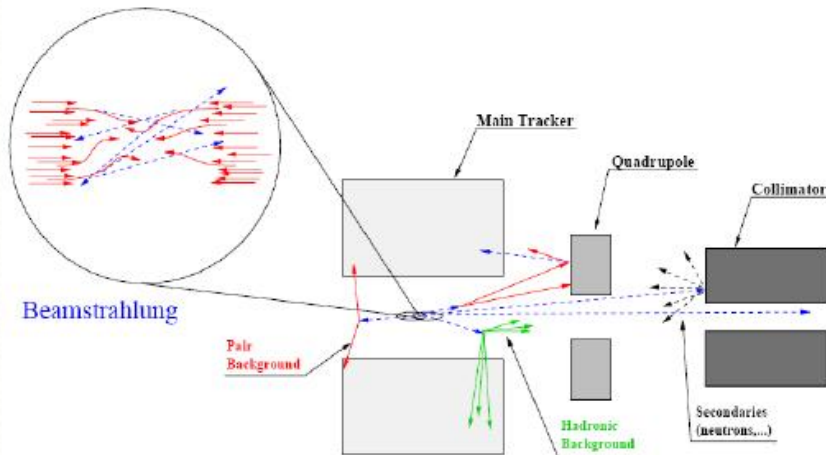

photons are very collimated around beampipe, but
 - $\approx 0.6 \times 10^5 e^+e^-$ -pairs per bunch crossing
 - ≈ 1 hadronic event ($\gamma\gamma \rightarrow$ hadrons) per 10 bunches
 - secondaries (neutrons, ...)

Consequences:

1. Shield Detector against low-angle e^+e^- -pairs and secondaries \Rightarrow Mask
2. Hadronic $\gamma\gamma$ -events might overlay real physics events: recognize them!

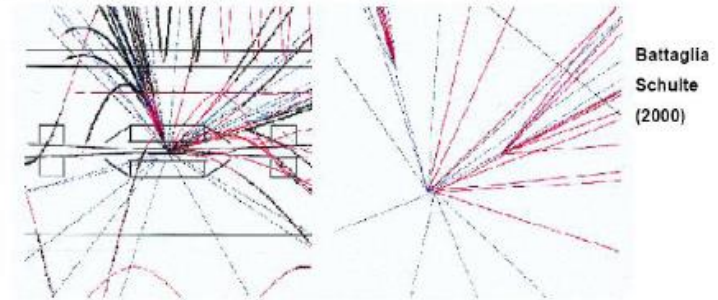

3. Beam particles lose energy before interaction (similar to ISR)

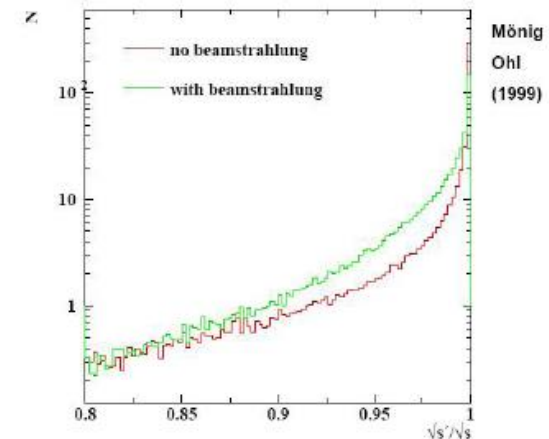

NEUTRONS IN DETECTOR

Neutron Production – Energies

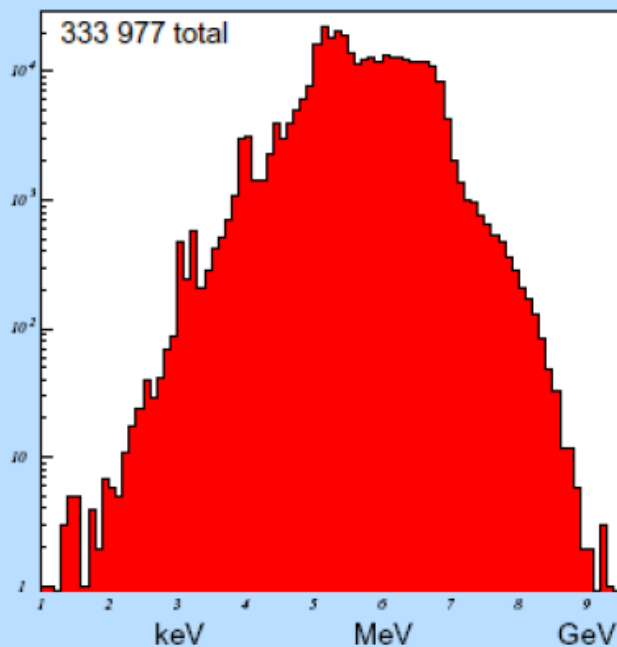

Energies of neutrons. . .

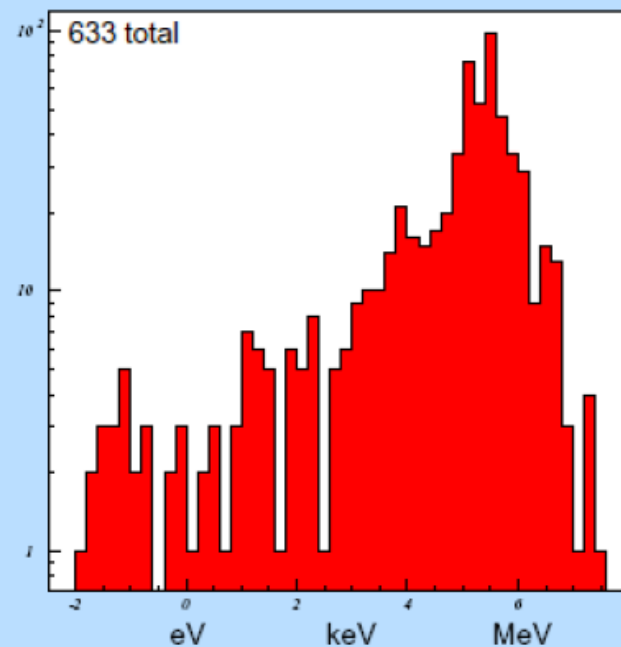

. . . when entering the TPC
(some more than once)

SYNCHROTRON RADIATION

See SR theory in A. Seryi's lecture

Concerns

backscattering from downstream
aperture limitations

edge- & tip- scattering from
upstream SR masks

impact of a partially-shared beam
line on SR masking (2mr):

compatibility of stay-clear
apertures (spent beam, pairs,
beamstrahlung γ) with
effective masking of
incoming SR

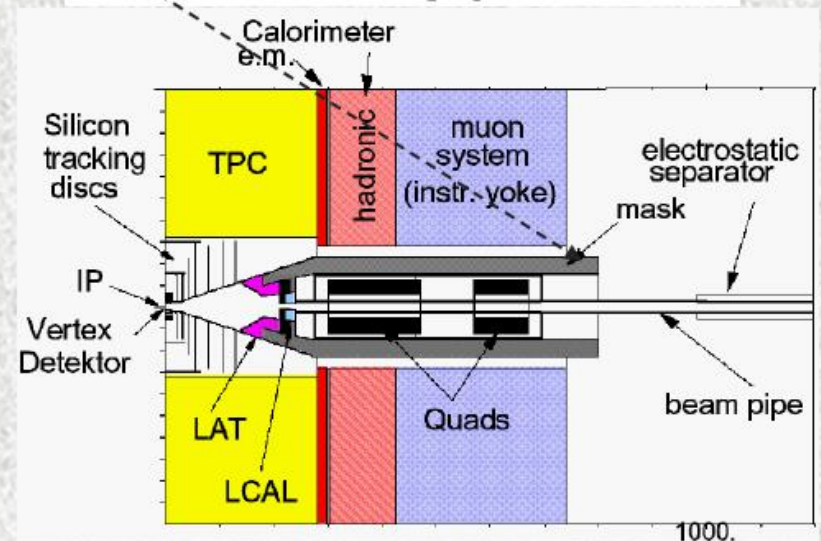
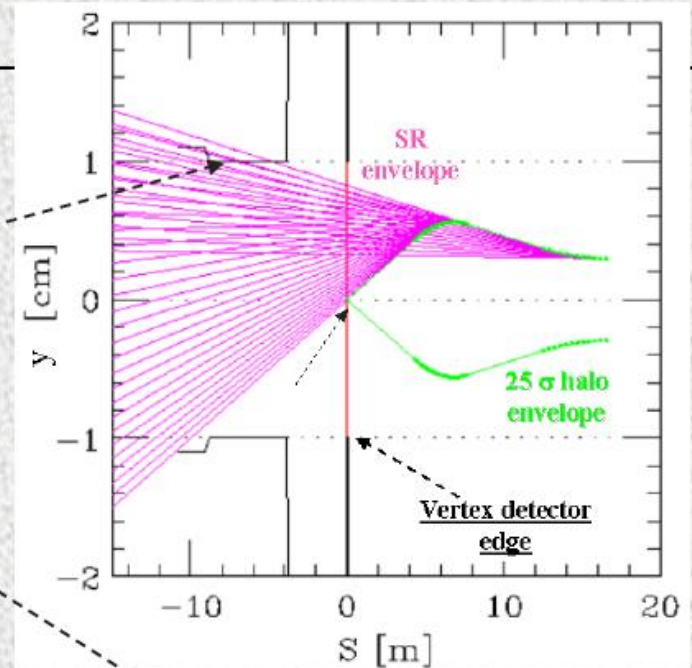

Hit Time Distribution in Muon Endcap

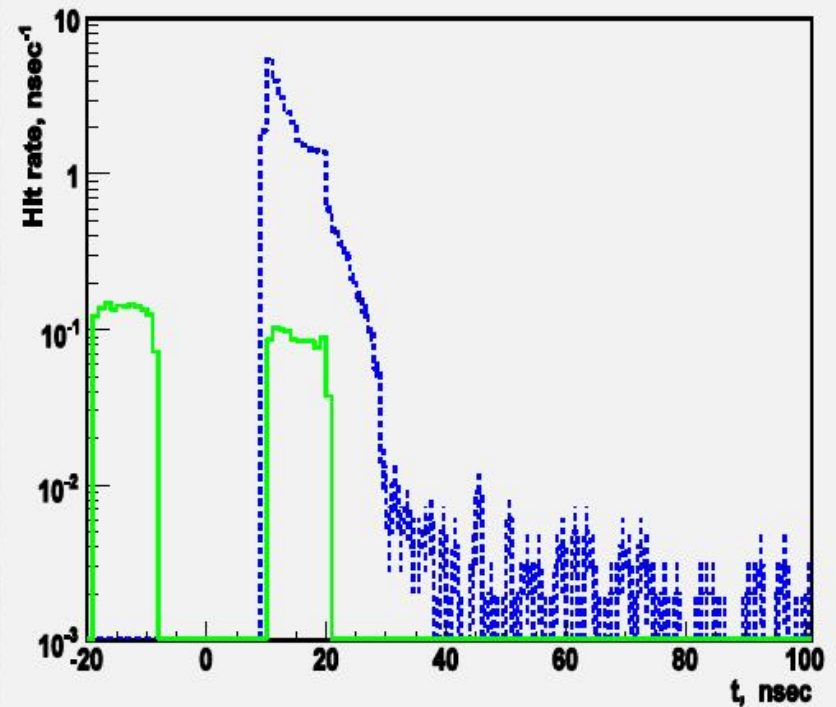
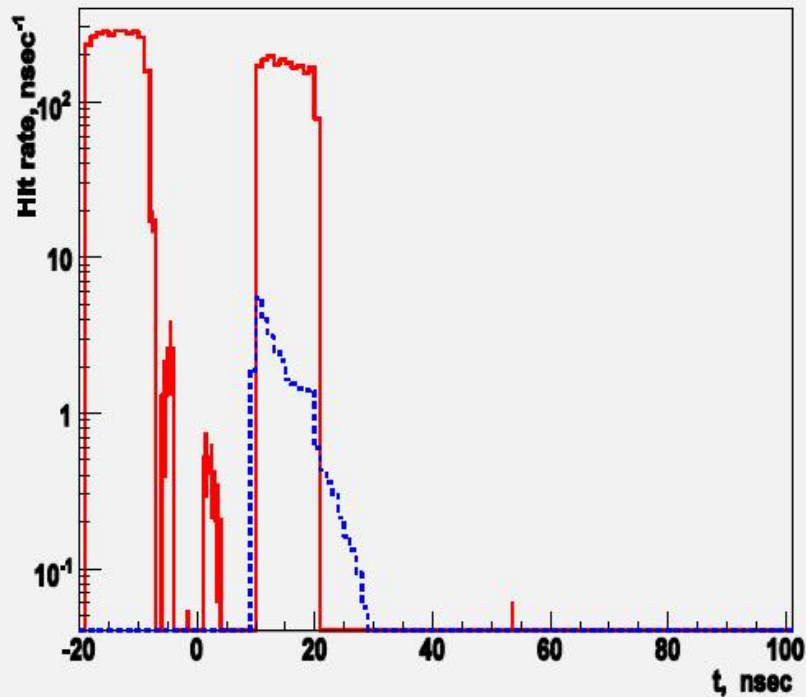

Red: machine background (no spoilers)

Green: machine background (with 9 & 18-m walls)

Blue: e^+e^- events

$t=0$ is bunch crossing.

BDS background
from e^+ tunnel only

Beam beam effects (1)

- In a collider the two beams feel each other's electric field well before and well after colliding.
- Given that the particles come very close to each other, this lead to very intense forces.
- These forces lead to significant disruption of the beam.

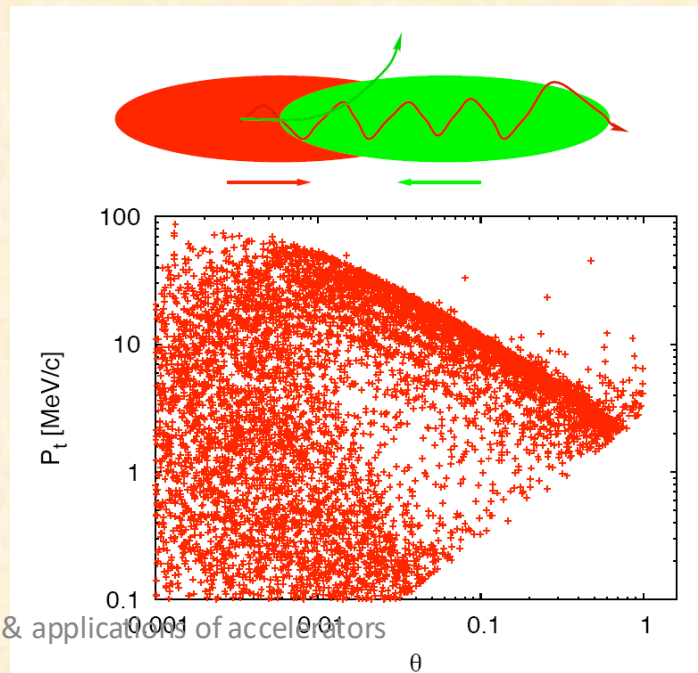

Beam beam effect (2)

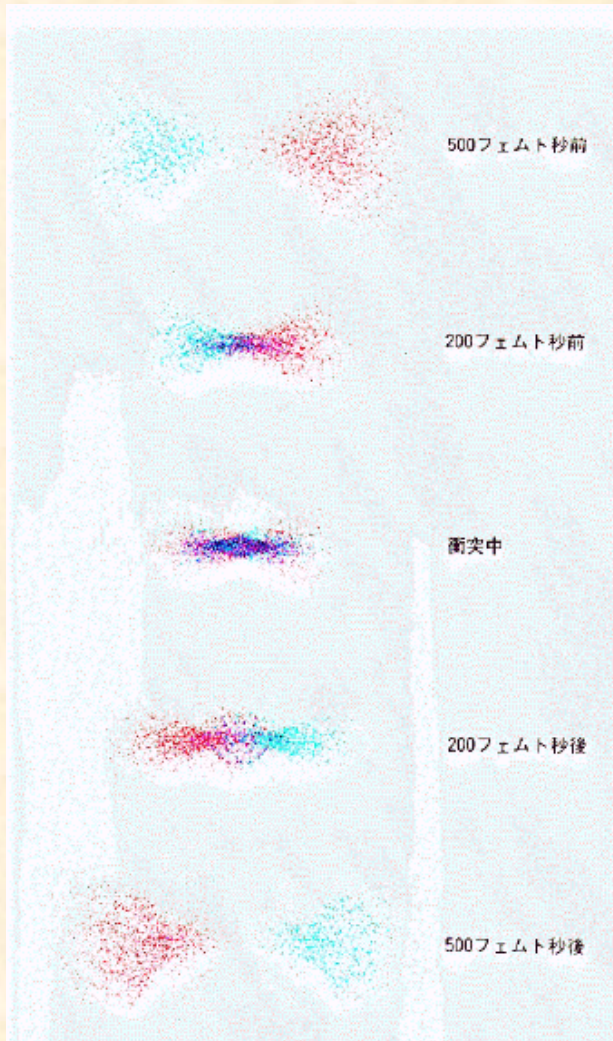

- At the interaction point the two beams self-focus onto each other.
- If the self focussing is too strong this can lead to a large emittance growth.
- If the two beam are not perfectly aligned this will also lead to large transverse deflection.
- This is a strong limitation on the size of the beams and therefore the luminosity, especially in a ring.

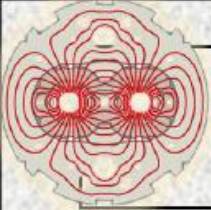

LHC: First collisions at 7 TeV on 30 March 2010

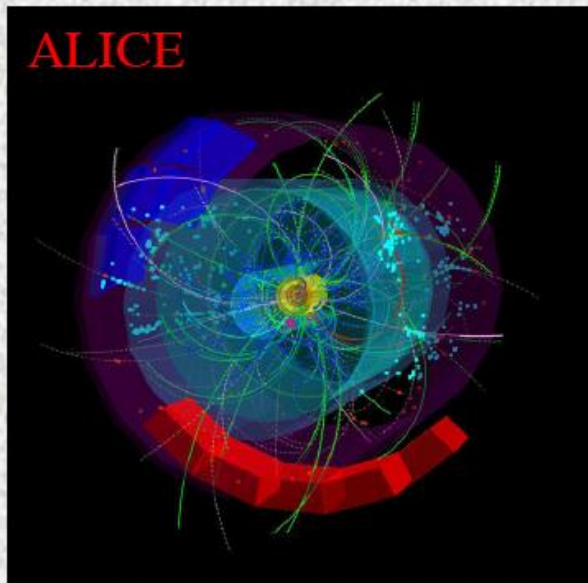

LHCb Event Display

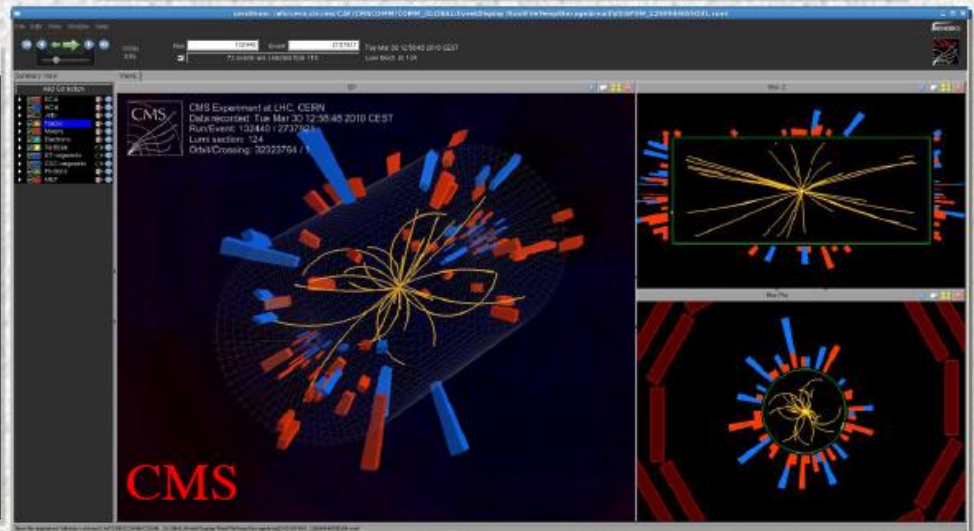
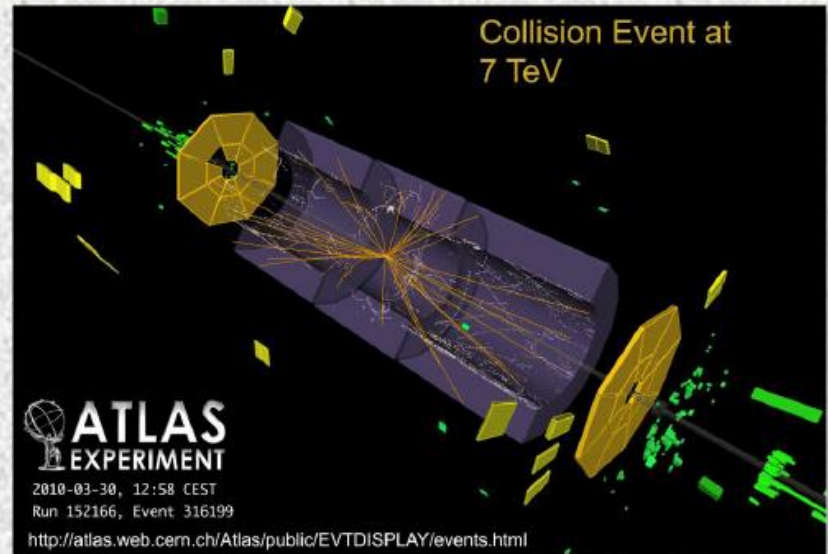
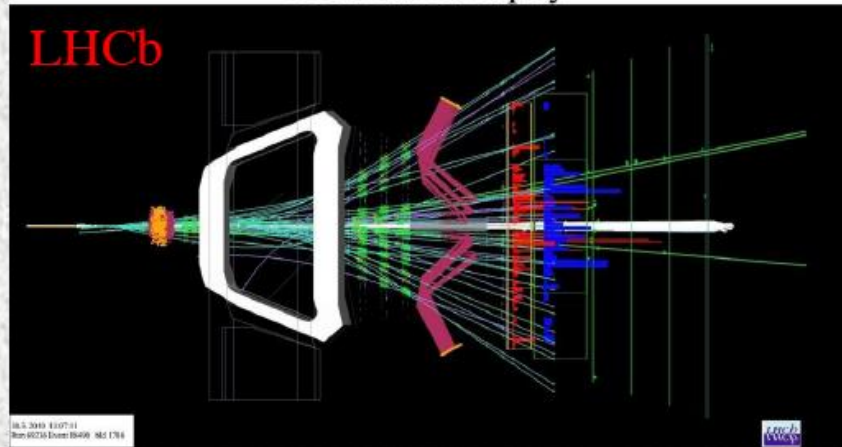

Three Sources of MIB

Compared to the luminosity-driven backgrounds at the IPs, machine-induced backgrounds (MIB) are less studied, their characteristics vary in a broader range, and - at a low luminosity - they can be a serious issue. The collimation system takes care of "slow" losses with a very high efficiency. But still three following components form the MIB at the detectors (considering LHC specifics):

1. **Tertiary beam halo** generated in the IP3 and IP7 collimation systems ("collimation tails").
2. **Beam-gas**: products of beam-gas interactions in straight sections and arcs upstream of the experiments and after the cleaning insertions.
3. **"Kicker prefire"**: any remnants of a missteered beam uncaptured in the IP6 beam dump system.

First Complete Studies of Machine Backgrounds at LHC

First complete study in 1996 by Mokhov, Drozhdin and Huhtinen:

NIM A 381 (1996) 531

Introduced the concept of "interface plane" at ~26m
(here detector simulations can take over from machine)

request to block tunnel entry
(to stop hadron & Em halo)
Request to never have beam
without TAS present

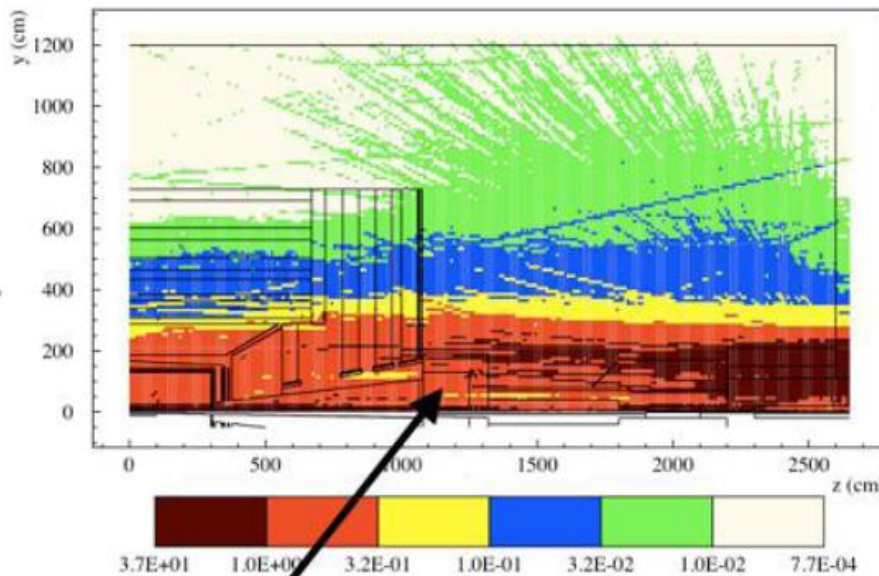

muons not an occupancy issue
-(compared to pp-background @ 1E34)

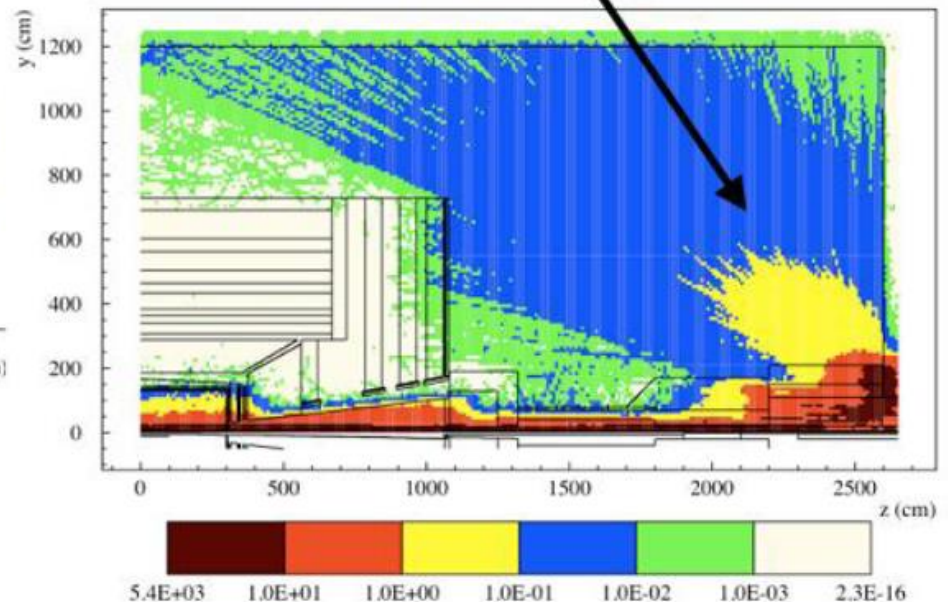

Effect on CMS and IP5 SC magnets of a kicker prefire studied first by MDH in 1999

Beam-Gas: Muon Flux Isocontours in IP5

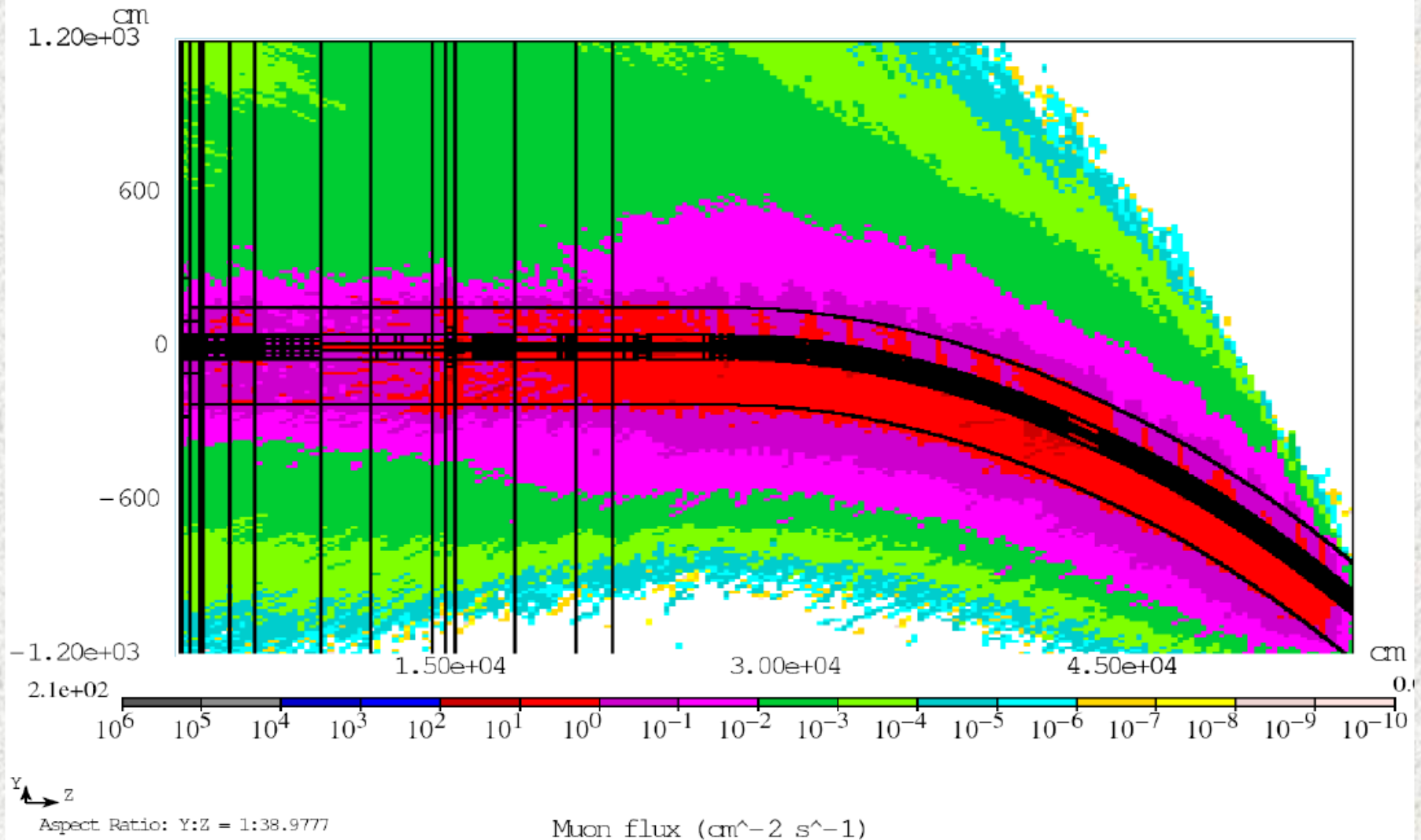

Kicker Prefire: Neutron Fluence

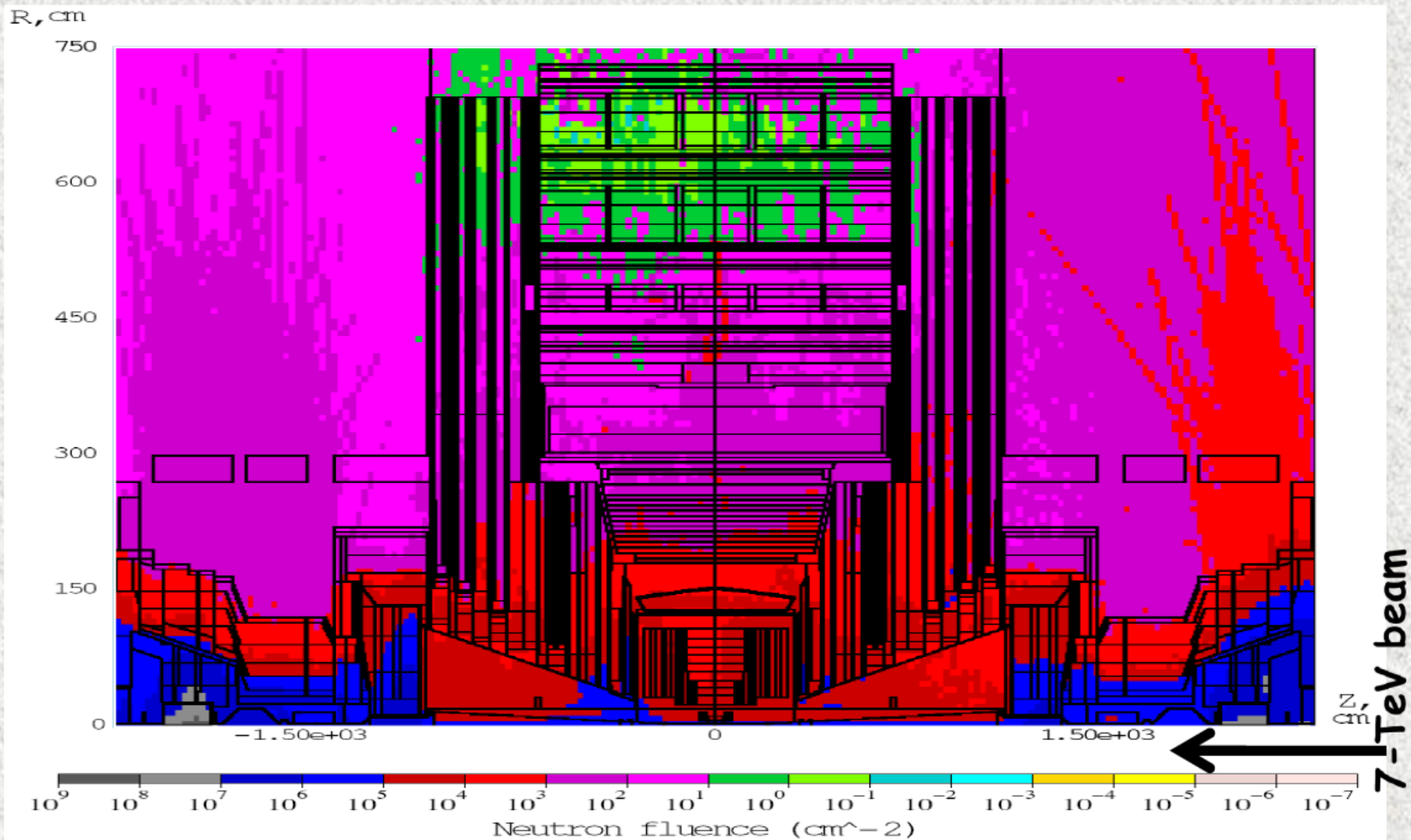

APPLICATIONS

Quizz

- Particle accelerators are not used only for HEP, they have many other applications.
- In which kind of institutions are there the more particle accelerators in the world?
 - (a) HEP lab
 - (b) Other physical sciences labs (non HEP)
 - (c) Museums
 - (d) Hospitals
 - (e) Other

Answer (d)

- HEP labs use the biggest particle accelerators in the world but there are only a few of them.
- Non HEP physical science labs use accelerators to produce X-rays. Every large country has 1 or 2 of such accelerators (SOLEIL and ESRF in France).
- Large museums like Le Louvres in Paris use particle accelerators to study cultural artefacts.
- Large hospitals use particle accelerators to treat cancer => a single hospital may have several accelerators!
- Most particle accelerators in the world are used for medical applications.

HEP applications of accelerators

- Most of the physics we are studying this week relies on particle accelerators.
- The LHC is the largest of these accelerators.
- Tevatron is (was) the second largest
- Others include B-factories (KEKB, PEP-II), c-factories, heavy ions accelerators (BNL, GANIL, Darmstadt,...),...
- Between 10 and 50 machines in the world...
- To ensure maximum luminosity, a low emittance, a low beta function and a flat beam are necessary.

$$\mathcal{L} = \frac{f N_1 N_2}{4\pi \sigma_x \sigma_y} \quad \sigma = \sqrt{\epsilon \beta} \quad \mathcal{L} = \frac{f N_1 N_2}{4\pi \sqrt{\epsilon_x \epsilon_y \beta_x \beta_y}}$$

Accelerators in England & Scotland



- There are more than 150 accelerators.
- Only 1 of them is used to teach HEP, all others are used for non HEP applications!

Accelerators Installed Worldwide

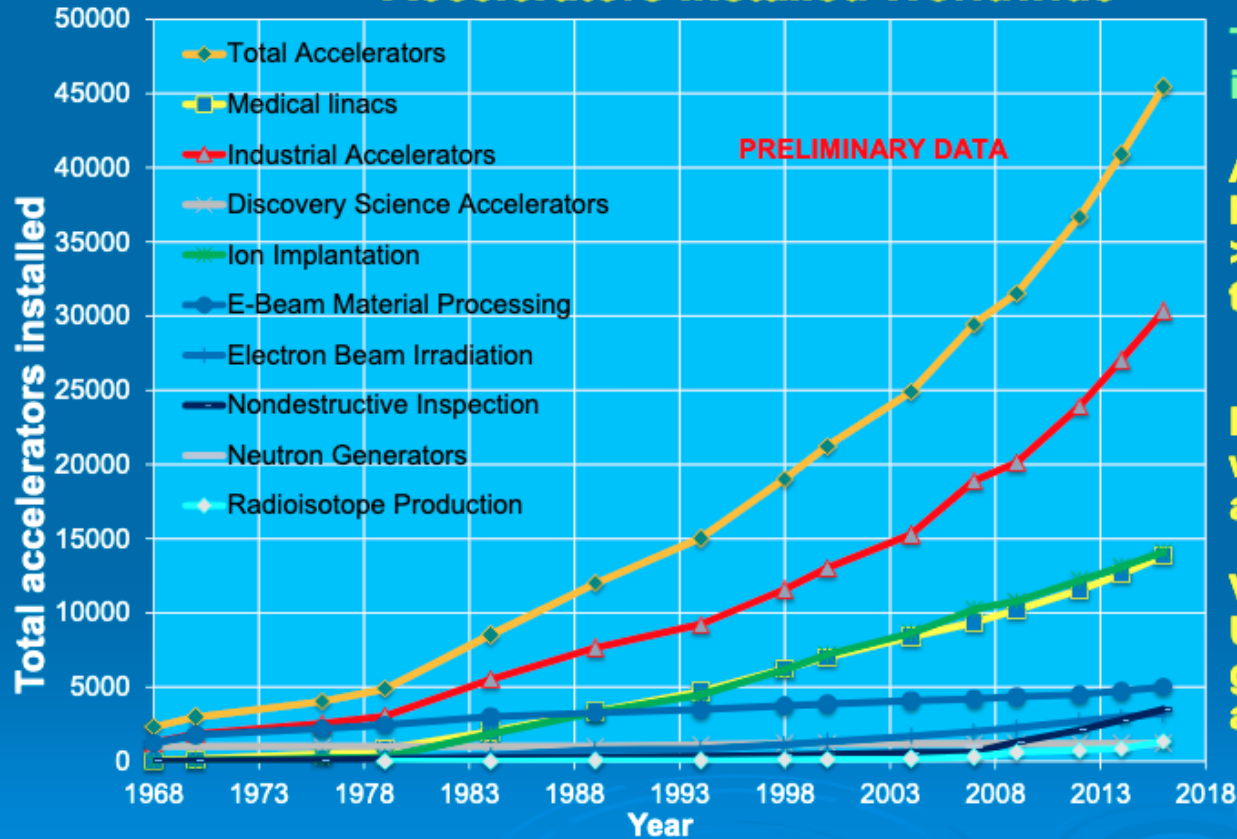

Total sales of accelerators is ~US\$5B annually

About 47,000 systems have been sold, > 40,000 still in operation today

More than 100 vendors worldwide are in the accelerator business.

Vendors are primarily in US, Europe and Japan, but growing in China, Russia and India

R. Hamm, Accelerator-Industry Co-Innovation Workshop, Feb 6, 2018, Brussels, Belgium

Courtesy of Lenny Rivkin

Non HEP applications

Dating old artefacts

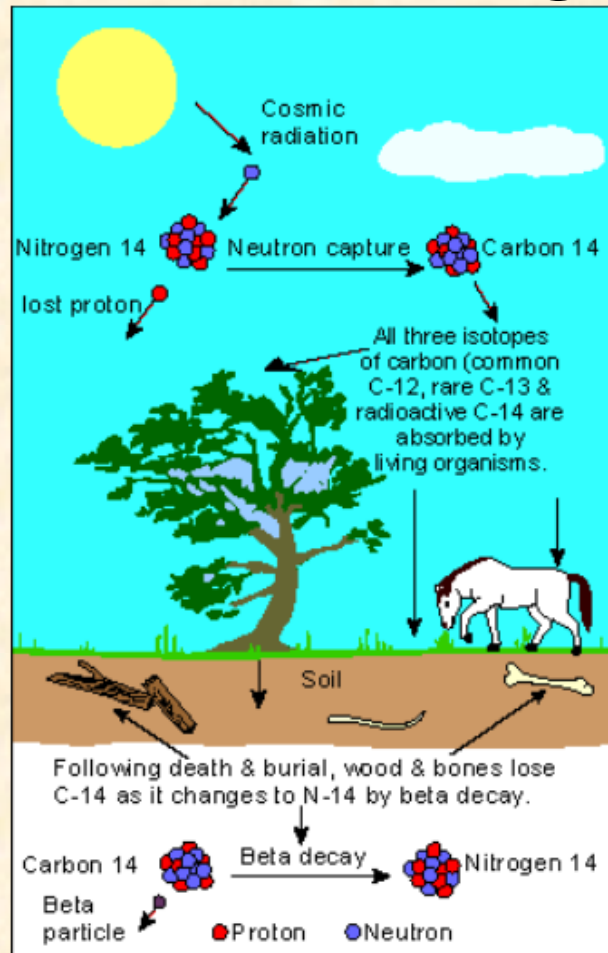

- Radiocarbon dating allows to measure the age of ancient artefacts.
- The ratio C13 vs C14 can be measured by using an accelerator.
- This technique is called “Accelerator Mass spectroscopy”.

Accelerator Mass Spectroscopy (1)

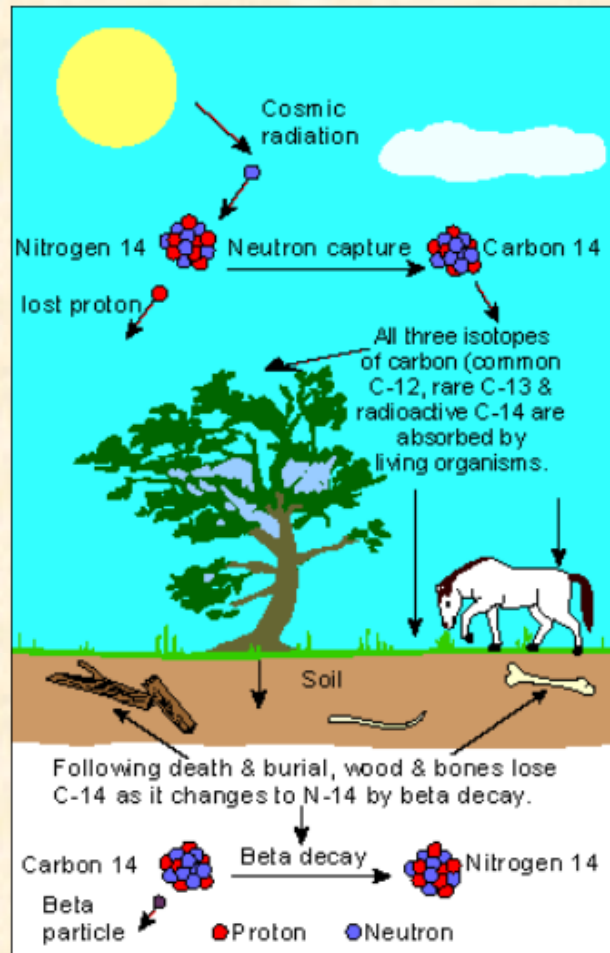

- In an AMS device the C12, C13 and C14 beams need to be separated to allow an accurate counting.
- An energy of 10-15MV is sufficient.
- Beam stability is very important to ensure good accuracy.

Accelerator Mass Spectroscopy (2)

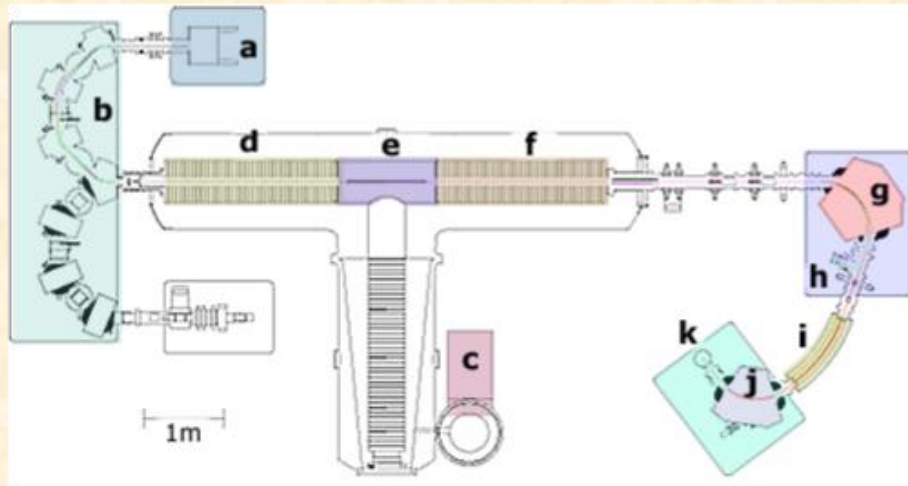

- AMS machines use a sputtering ion source producing C- ions.
- A tandem Van de Graaff is then used to accelerate the ions and strip them to C³⁺.
- A DC accelerator offers a better stability than a RF accelerator.
- A Faraday cup is used to measure the beam charge.



Example of AMS application

Vinland map



- AMS was used to date ashes found in Newfoundland in a European-type settlement. These ashes were dated back to the XIth century.
- A viking map featuring Newfoundland was shown to be older than Columbus trip to America.
- AMS has contributed to establish that North America was visited by Vikings well before other European nations.

Dating old artefacts...



- There are many other accelerator based dating techniques which I do not have time to cover.
- Proton, Neutron and light sources can all be used to investigate some properties of old artefacts.
- Left:
Roman Jug dated by ISIS.

Treating Cancer

- Some type of cancer tumors are located at places difficult to reach by Surgery.
- X-rays can be used to kill such tumors.
- This is called Radiotherapy.
- Radiotherapy need 10-15 MeV electrons for a few seconds.
- The accelerator needs to be compact so that it fits in an hospital room and fields can be contained.

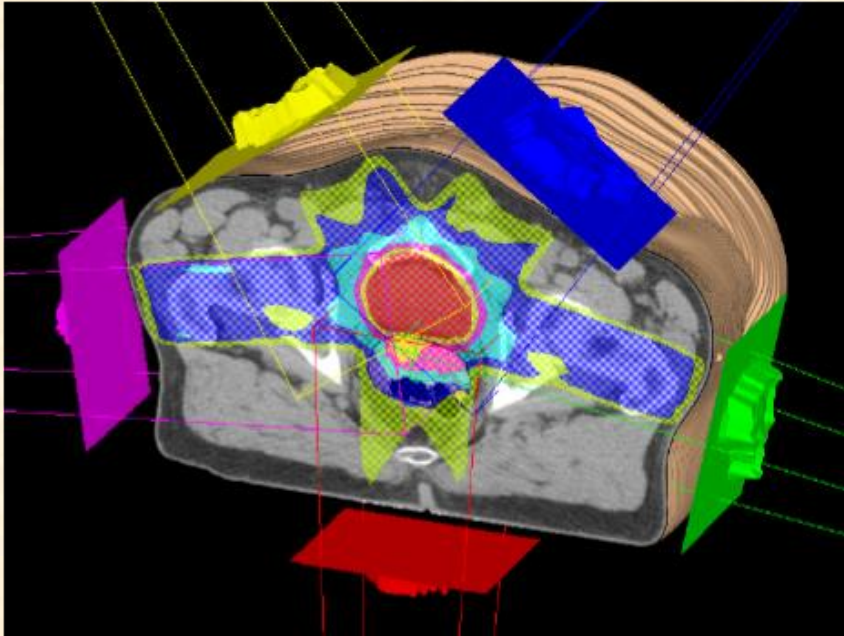

Medical linac

- Radiation therapy uses small 15MeV “linacs”.
- It is safer to produce a low current over several pulses rather than a high peak current over a few pulses, hence a thermionic gun is used (such gun are also more reliable and easier to maintain).
- To reach 15 MeV with a large electrostatic accelerator would require a large installation likely to frighten the patients.
- A short RF accelerator is used to reach the required energy.



Radiotherapy

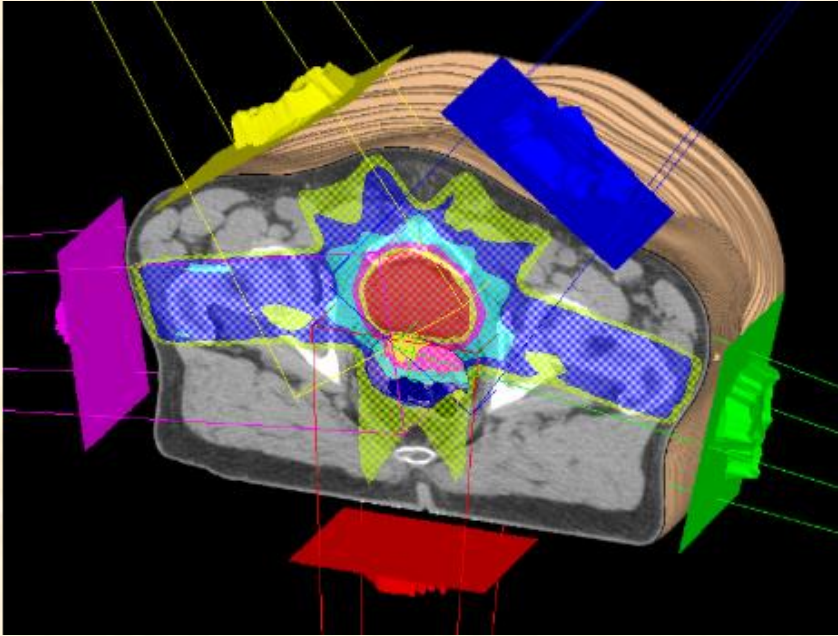

- X-rays are used to kill a tumour.
- To minimize the dose sent on healthy tissues several X-ray beams are sent in turn from different directions.
- However this technique is not ideal due to its impact on healthy tissues.

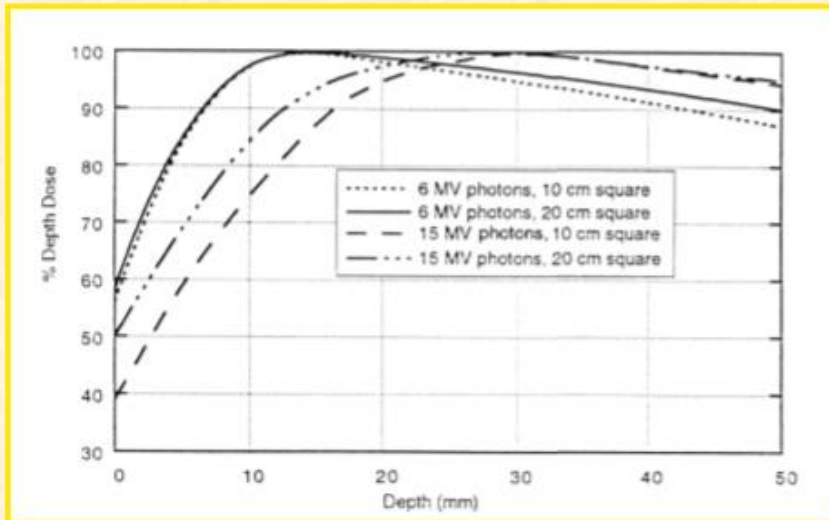

Proton and ion therapy

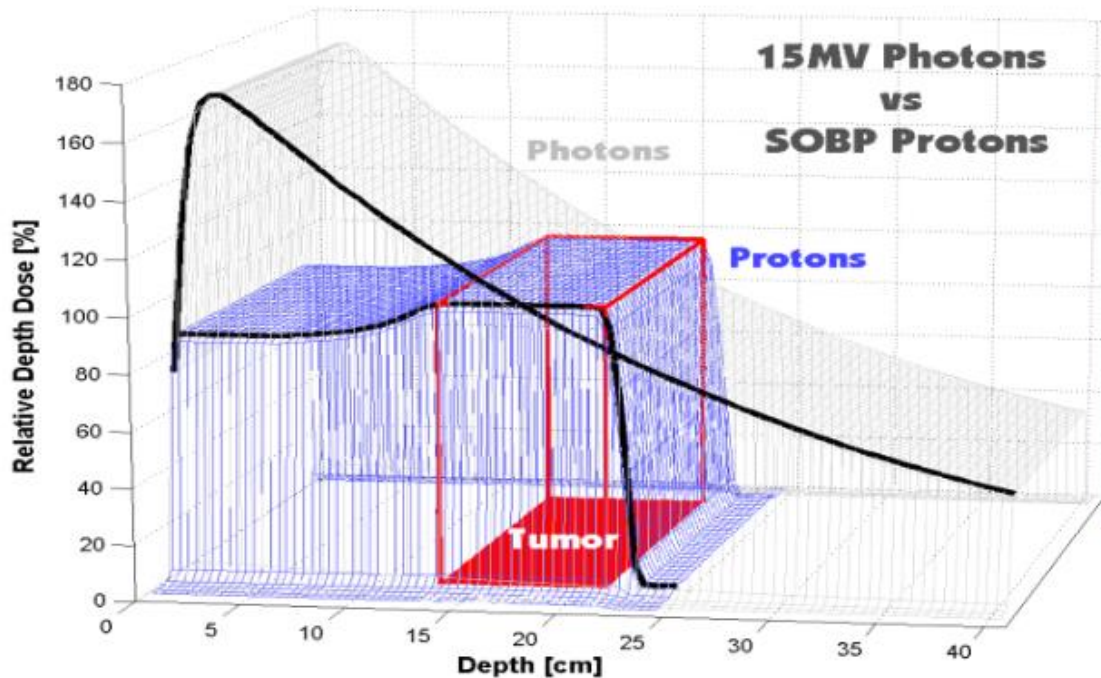
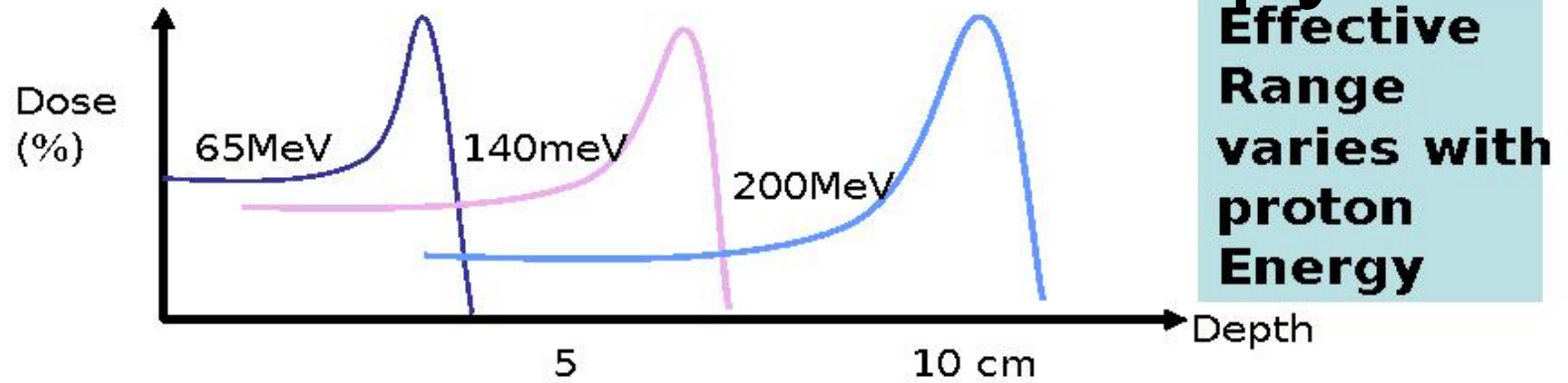

The 'spread out Bragg Peak - plateau effect [SOBP]

Source: Bleddyn Jones, JAI graduates lectures

A possible solution...

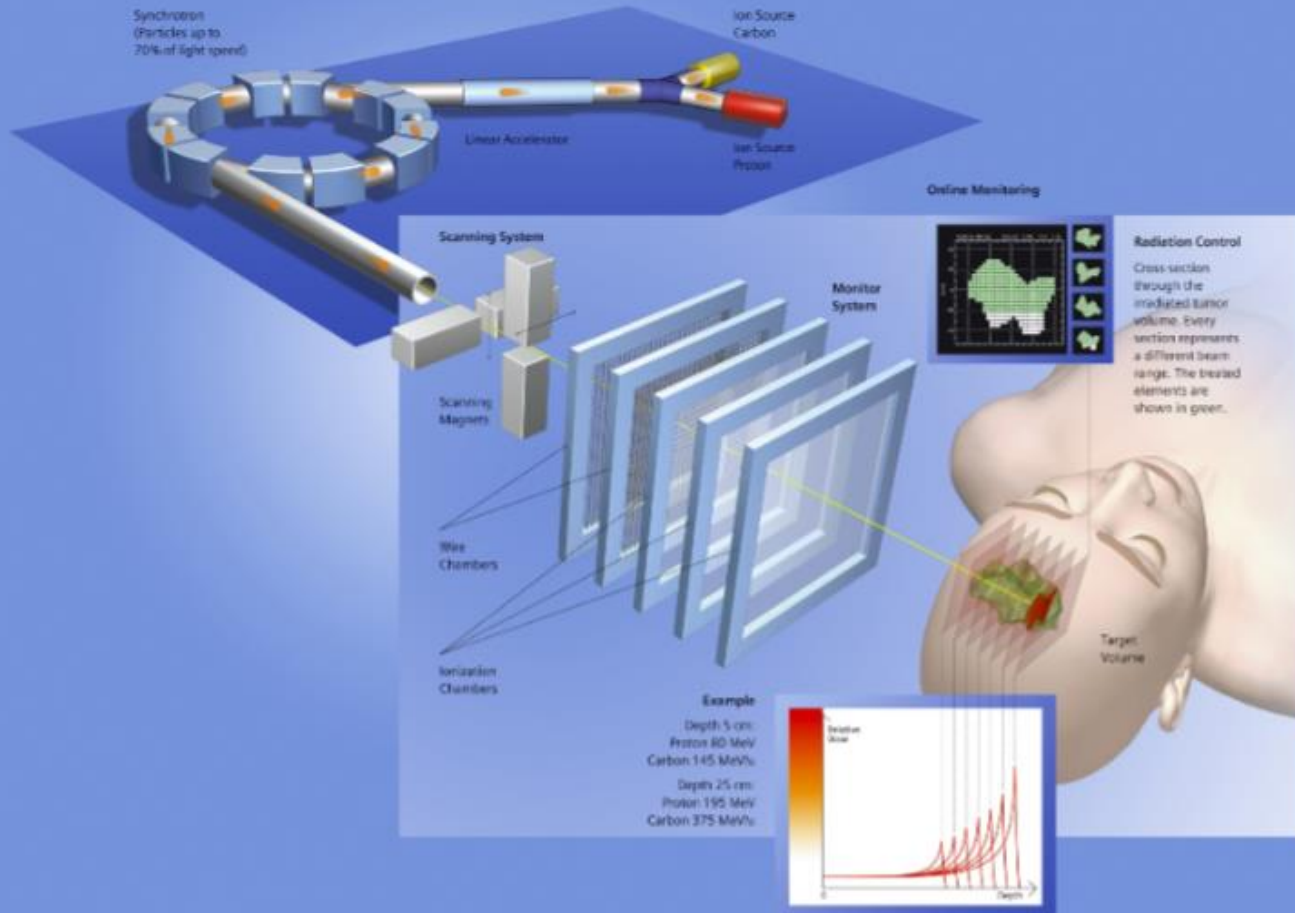

Source: Bleddyn Jones, JAI graduates lectures

Medical cyclotron

- Cyclotrons are well suited to accelerate ions.
- Several hospitals or universities are equipped with cyclotrons to produce radioactive isotopes used as markers in drugs.
- Such a cyclotron is a commercial product.

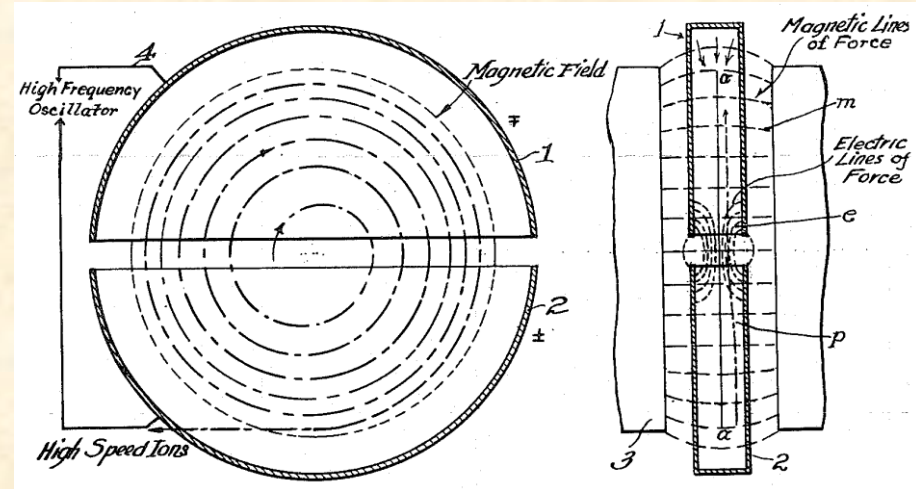

Pharmaceutical drugs

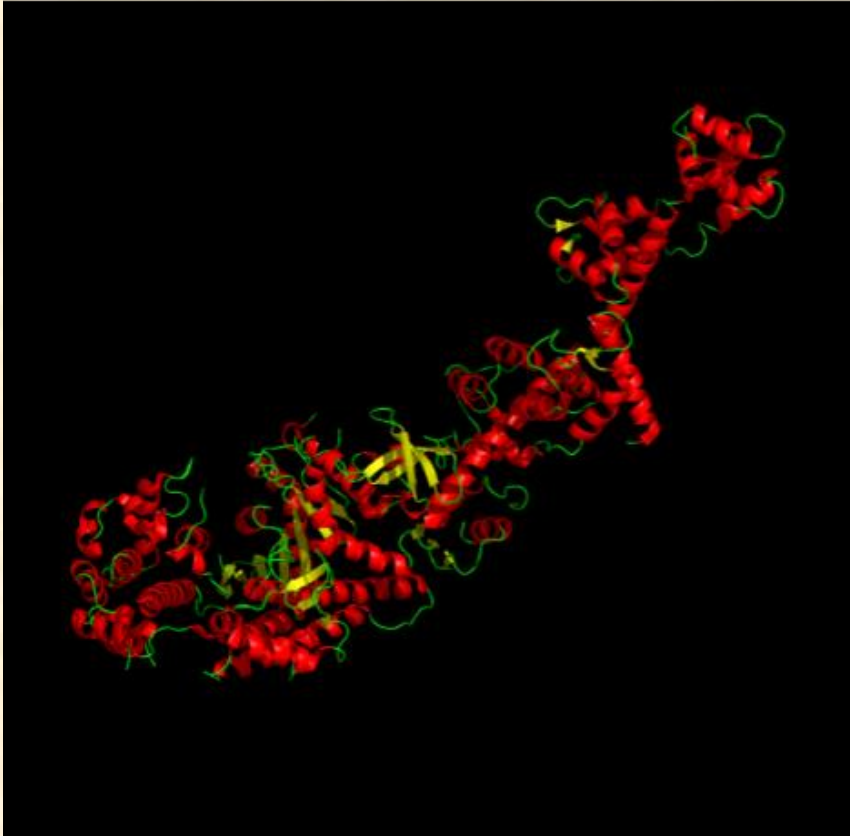

- To be efficient a drug need to target the correct molecule.
- This can only be achieved by studying the diffraction of intense on the molecule.
- What type of machine (gun, accelerator, ...) is best suited to deliver an intense stable beam of X-rays?

A source of intense X-rays

- Synchrotrons are best suited to deliver intense beams of X-rays.
- Although synchrotrons operate at ultra low emittance the gun can be thermionic as radiation damping reduces the transverse emittance.
- A RF accelerator is then used to accelerate the particles up to the ring energy. A booster may be used to reduce the length of the linac.



Source: Diamond

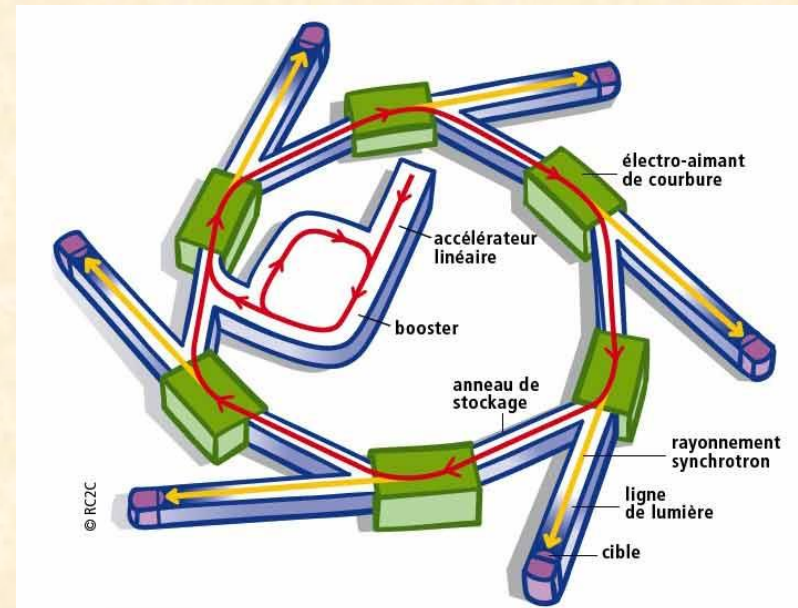

Source: SOLEIL

Applications of synchrotrons

- Light sources have a wide range of applications.
- A light source in England has been used to improve the quality of chocolate!
- Diamond is being used to study old manuscripts too precious to be opened!
- Protein imaging, drugs, material studies,...
- GMR (the phenomena that allows dense magnetic storage in your ipod) has been studied with light sources.



The next generation of light sources

- The drawback of using radiation damping to reach ultra-low emittance is that the beam is stretched longitudinally.
- This means that the X-ray pulse have a long (ps) duration.
- Some applications require fs long high brightness X-ray pulses...
- How can this be achieved?

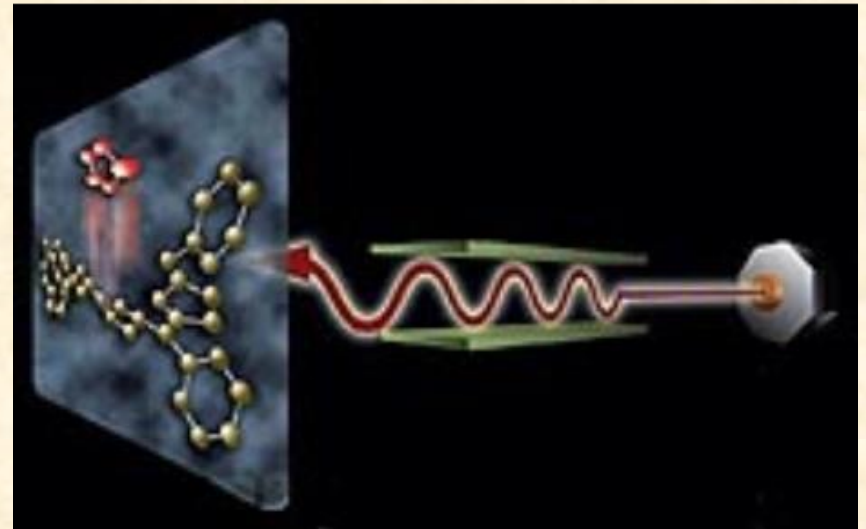

Next generation: Linac based Free electron lasers

- Only linac based accelerators can deliver ultra-short pulses.
- Ultra-short pulses are necessary to get coherent emission of X-rays.
- Hence the emittance must be ultra-low from the start.
- This requires a photo-cathode RF gun.
- With an ultra-low emittance it is possible to achieve lasing in the undulators (and thus an even higher light output).

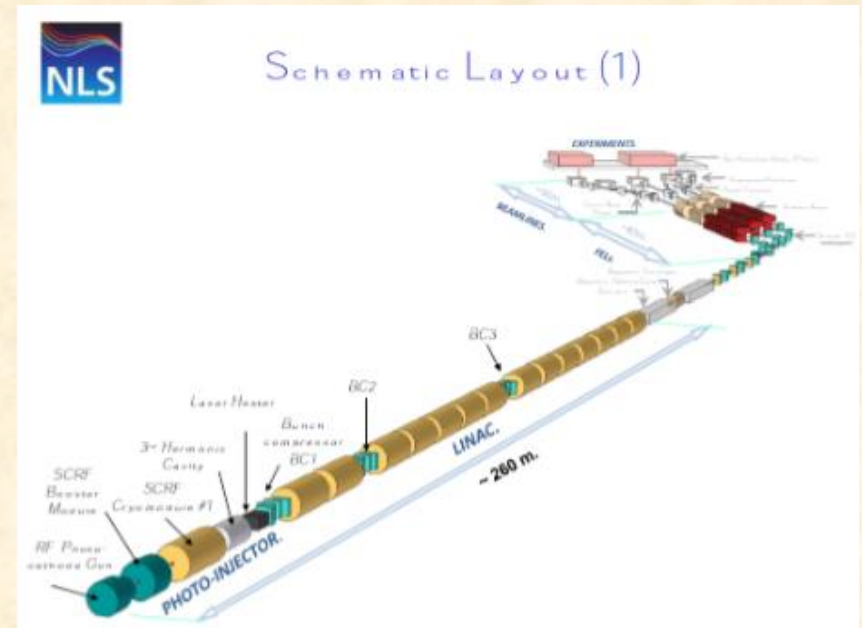

How to make short bunches?

- RF guns can be used to make short pulses.
- To have even shorter pulses one needs to use a compression scheme.

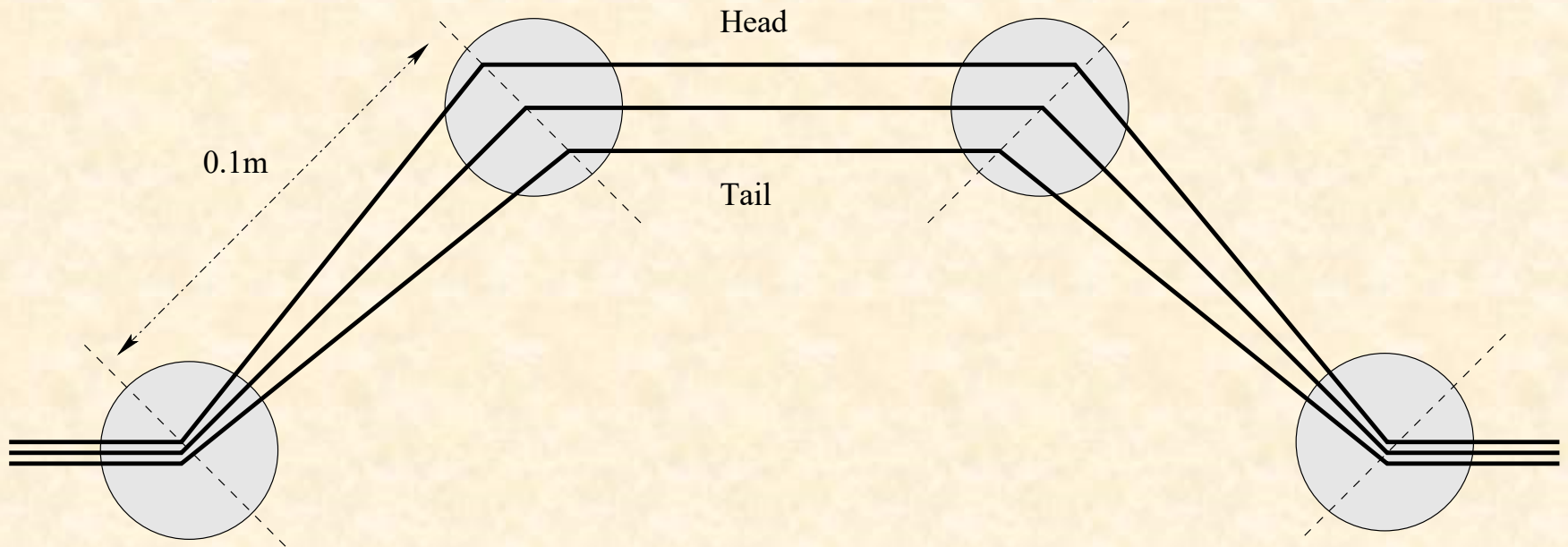

Neutron crystallography

- X-ray crystallography can only be used on matter that is rather transparent to X-rays.
- Other objects such as this Roman vase or the materials used to build an aircraft need a probe that penetrate deeper in the material: Neutrons.
- How can we produce neutrons?



Neutrons sources

- It is not possible to directly accelerate neutrons.
- However neutrons are produced when a target is bombarded with protons.
- The ISIS neutron source requires 800 MeV protons.
- How to build this?



A neutron source: ISIS

- A proton synchrotron can be used to bring the protons to the right energy.
- Emittance is not a challenge at the target location but a low emittance beam helps minimizing the losses in the accelerator (and hence the activation).
- Note that it is easier to accelerate H^- than H^+ .

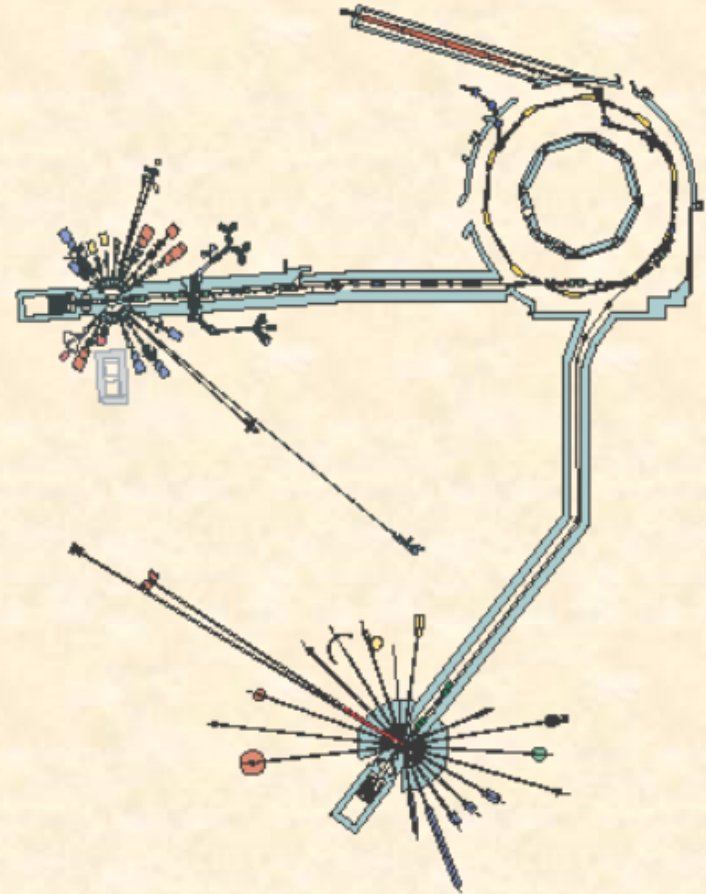

Spallation

- Spallation is a process in which fragments (protons, neutrons,...) are ejected from a target atom hit by a high energy proton.
- Such target is very challenging as most of the proton power is deposited in the target.

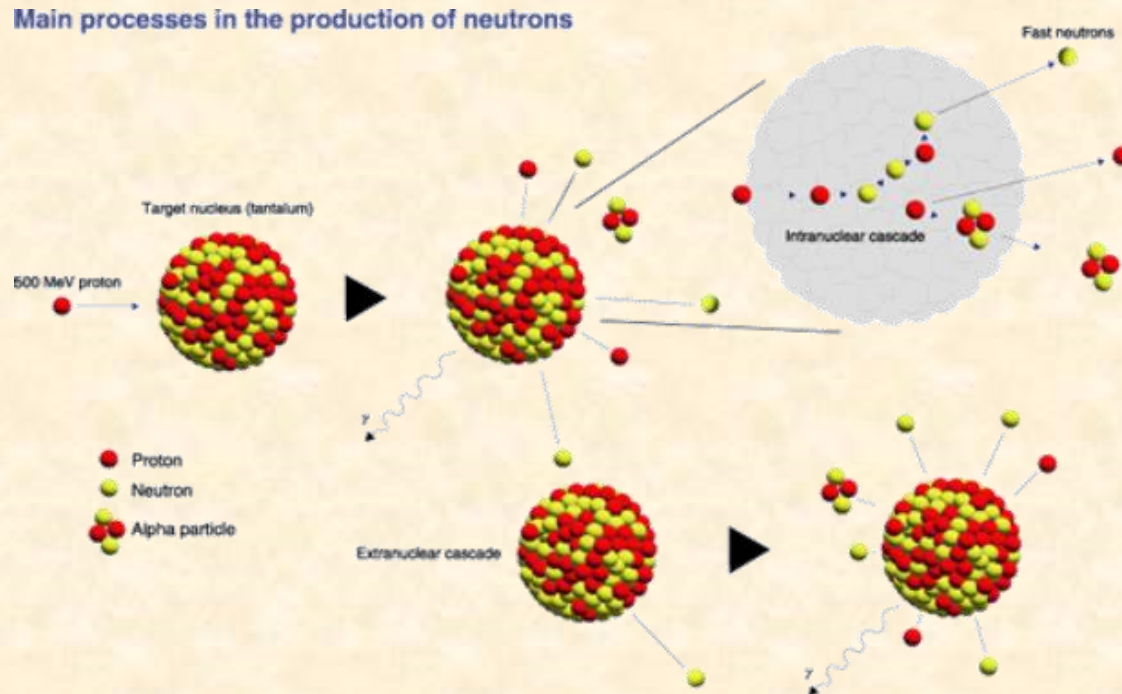

Spallation target

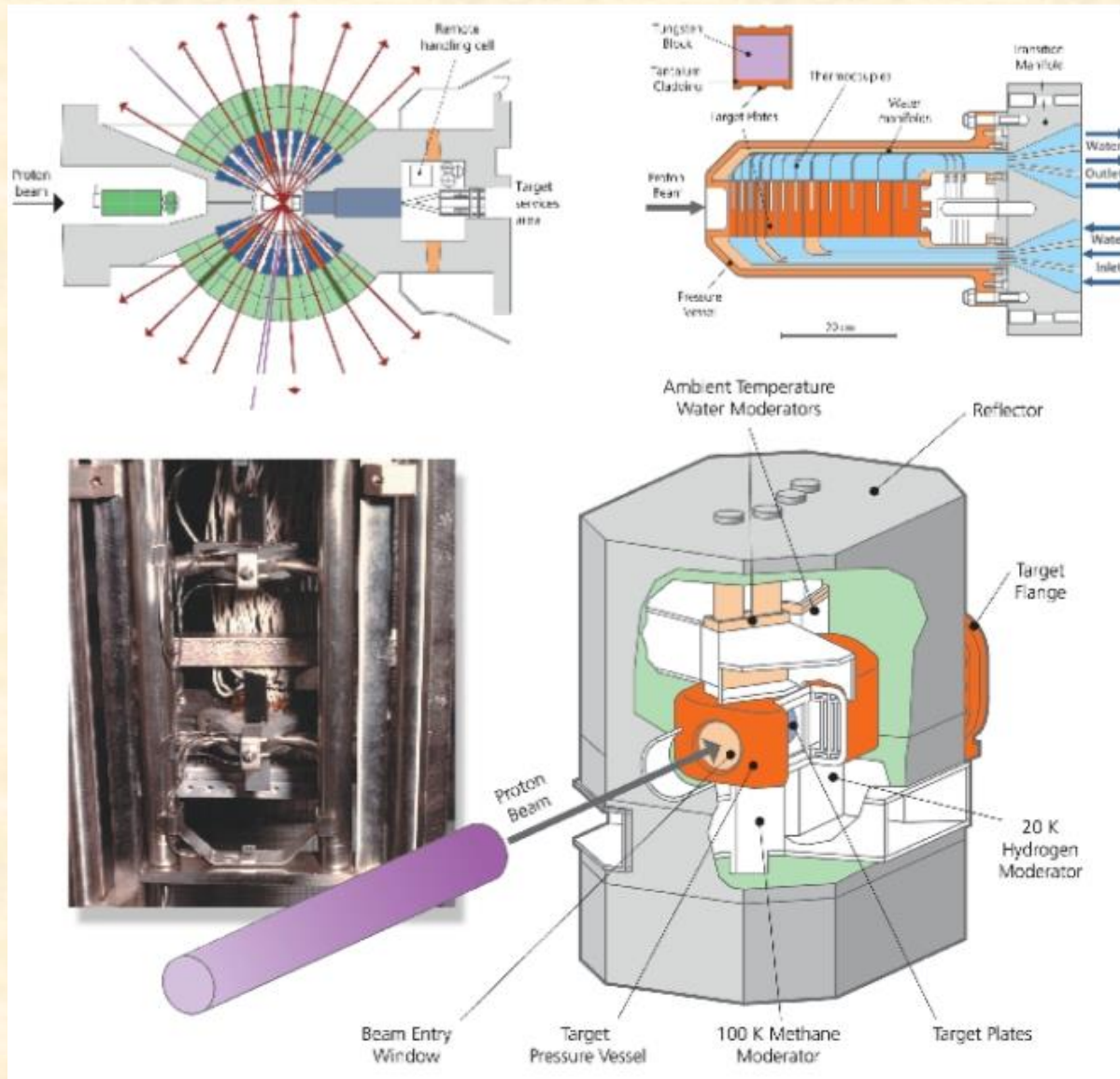

Accelerator Driven sub-critical reactor (ADS)

- An intense source of protons could be used to produce an intense flux of neutrons.
- After moderation these neutrons would trigger nuclear reactions in some nuclear material.
- Advantage the reactor can operate in sub-critical mode (if the accelerator stops the nuclear reactions die automatically).
- The nuclear fuel could be made of isotopes that can not sustain a chain reaction (such as Thorium).
=> no risk of proliferation.

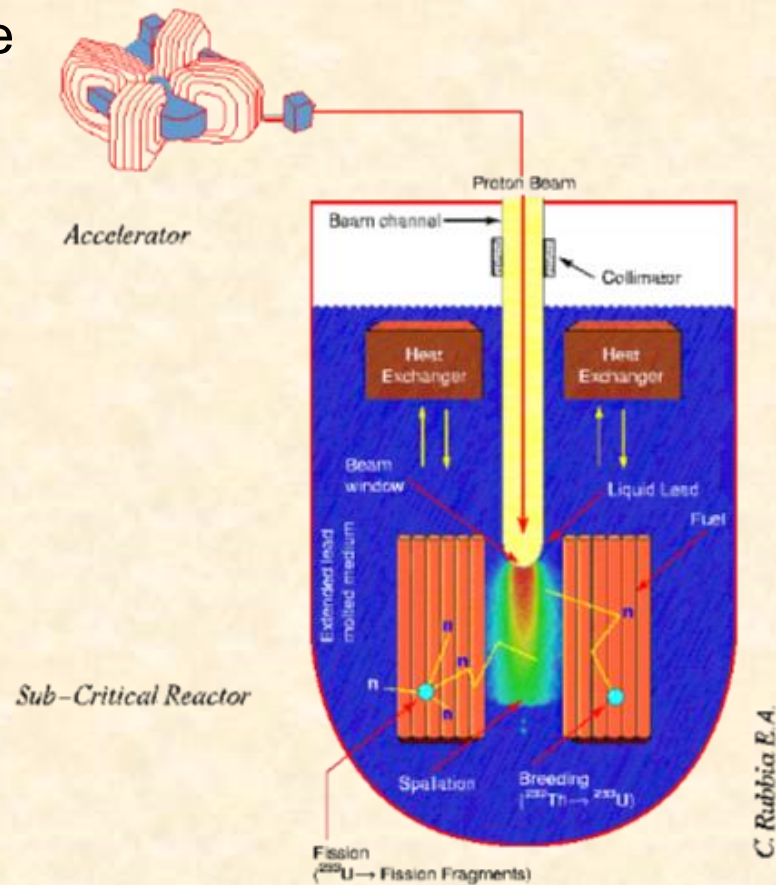

Need for high redundancy

- Even if they do not like it, HEP experiments can cope with an unreliable accelerator.
- In a nuclear reactor a sudden stop of the driver will cause a thermal shock.
- To many thermal shocks might damage the containment vessel => The accelerator has to have a high level of reliability.

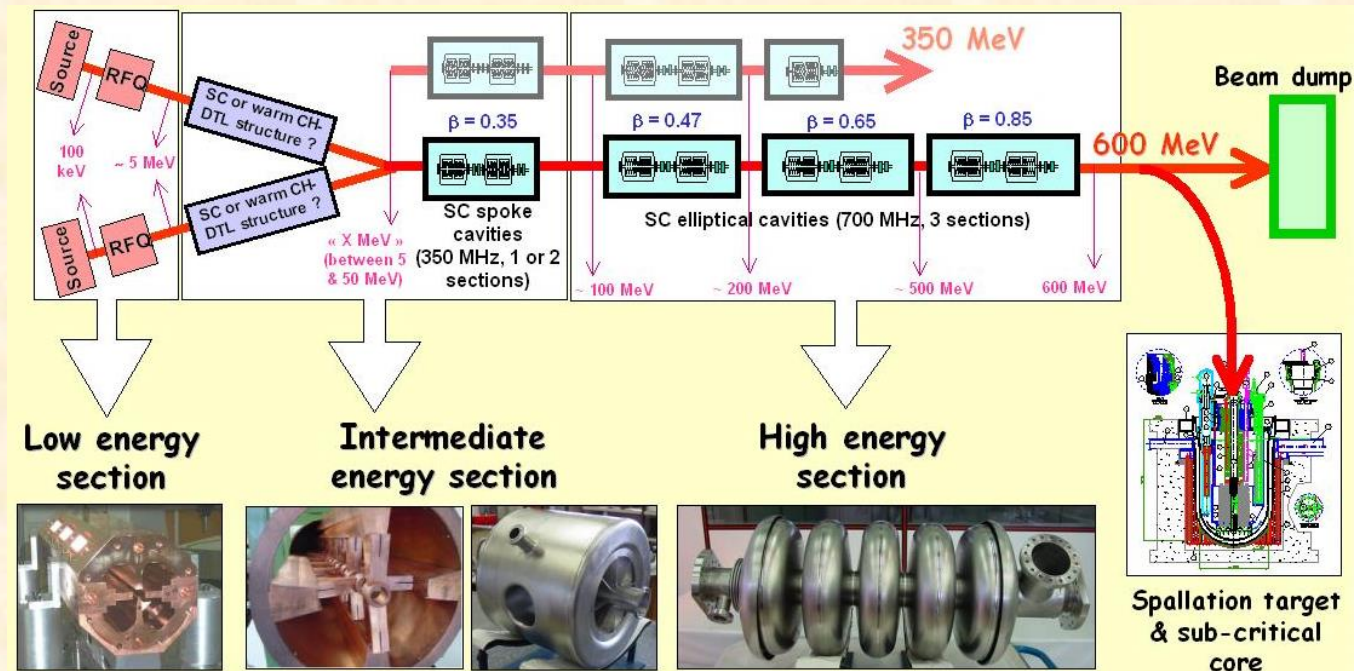

Applications of accelerators to the environment

Fine Particle PM2.5 IBA Characterisation

Typical fine mass filters for 24 hour collection weighs ~300µg.

Filters analysed using nA beams of MeV protons and IBA techniques give over 30 different elemental and chemical species.

Analysis does not destroy the sample.



Exposed stretched Teflon filter, optimised for IBA analysis.

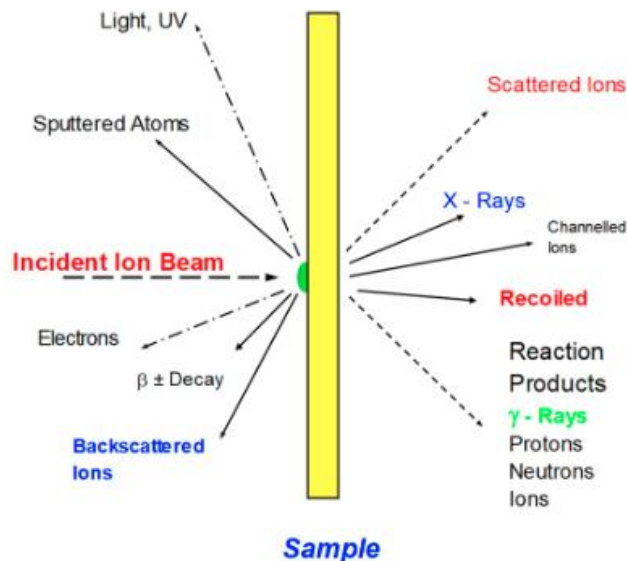

ANSTO 2MV STAR accelerator

PIXE – Interactions with electrons, characteristic keV x-rays from Al to U

PIGE – Interactions with nucleus, gamma rays for light elements (Mg, Al, F, Na..)

RBS – Rutherford Backscattering for C, N, O ..

PESA – Particle Elastic Scattering analysis for total H content.

These 4 techniques can be run simultaneously in a few minutes and provide data from H to U with sensitivities of (µg/g) on sample sizes as small as pg.



Environment

Degradation of pollutants in water, air and soil

- high-efficiency removal of NO_x and SO_x from flue gases
- treatment of marine diesel exhaust gases
- purifying drinking water
- treating industrial or hospital waste water
- disinfecting sewage sludge
- remediation of Hydrocarbon contaminated soils

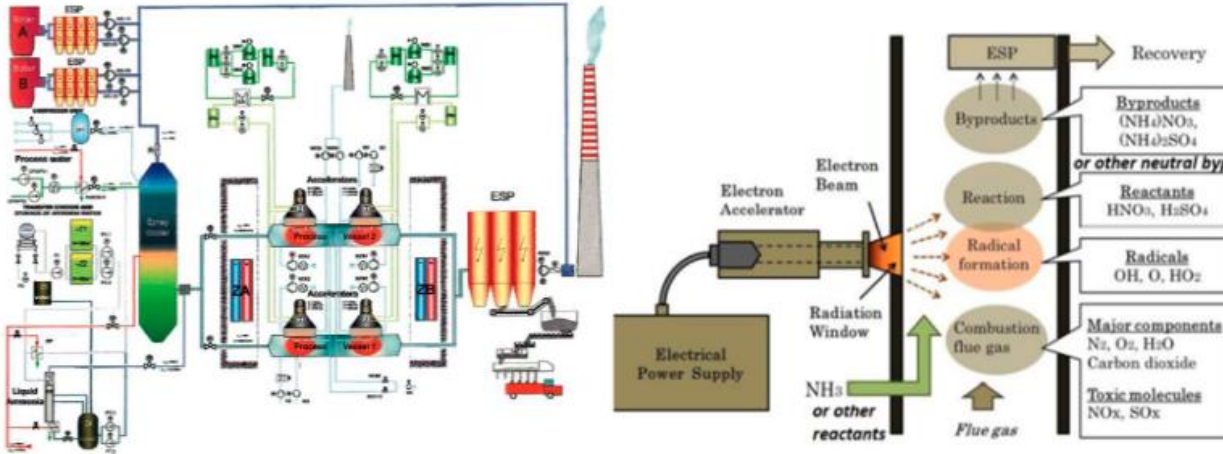

projects in Poland, Japan, USA, Germany, and China



Reduction of pollution by polymer degradation

- powdered Teflon for lubricants, high quality inks
- cellulose in viscose industry
- wood pulp in paper industry

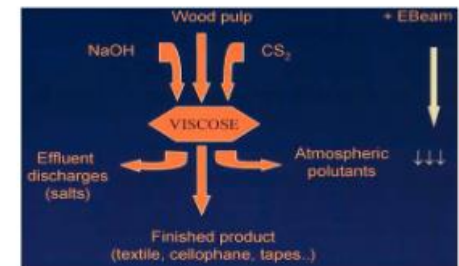

Courtesy of Wim Mondelears

Uses of Radiation Sources: Food and Agriculture [1]

- Food irradiation (cobalt-60 and cesium-137):

Dose	Purpose	Products
Low dose (< 1 kGy)	<ul style="list-style-type: none">• Kill parasites, insects, and larvae• Inhibit sprouting• Slow ripening	<ul style="list-style-type: none">• Meat• Flour, rice, grains• Potatoes, garlic, onions
Medium dose (1-10 kGy)	<ul style="list-style-type: none">• Pasteurize to eliminate food borne illnesses caused by microbes	<ul style="list-style-type: none">• Fruits, meat, seafood
High dose (>10 kGy)	<ul style="list-style-type: none">• Sterilize food for immunocompromized patients	<ul style="list-style-type: none">• Hospital food



NON - IRRADIATED



IRRADIATED

<https://iaea.org>

Accelerators (or radiation sources) can sterilize food

Courtesy of Valeriia Starovoitova

- Sterile Insect Technique (cobalt-60 and cesium-137)

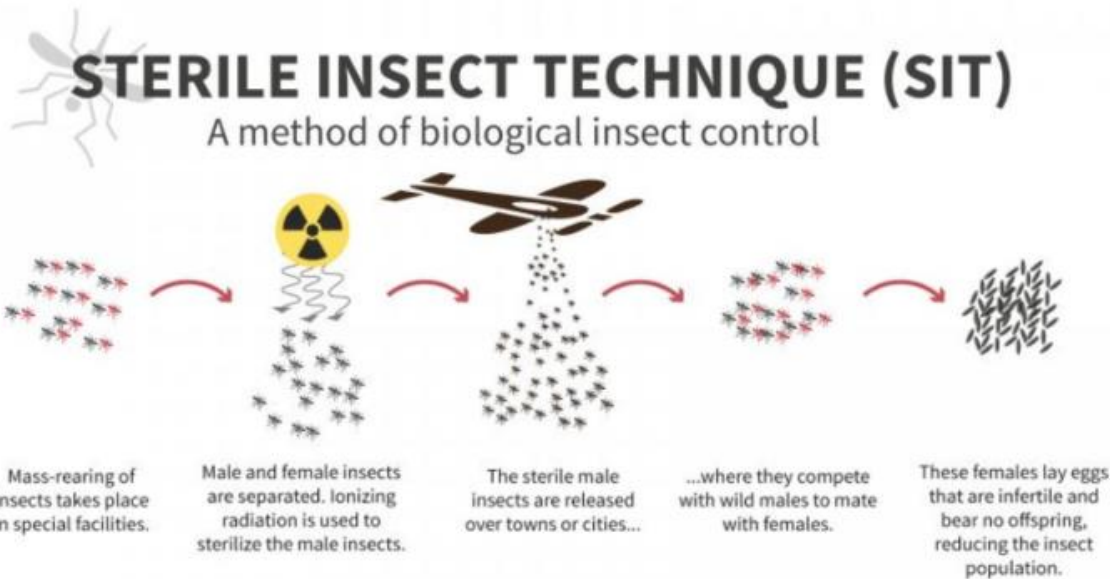

<https://iaea.org>

Courtesy of Valeriia Starovoitova

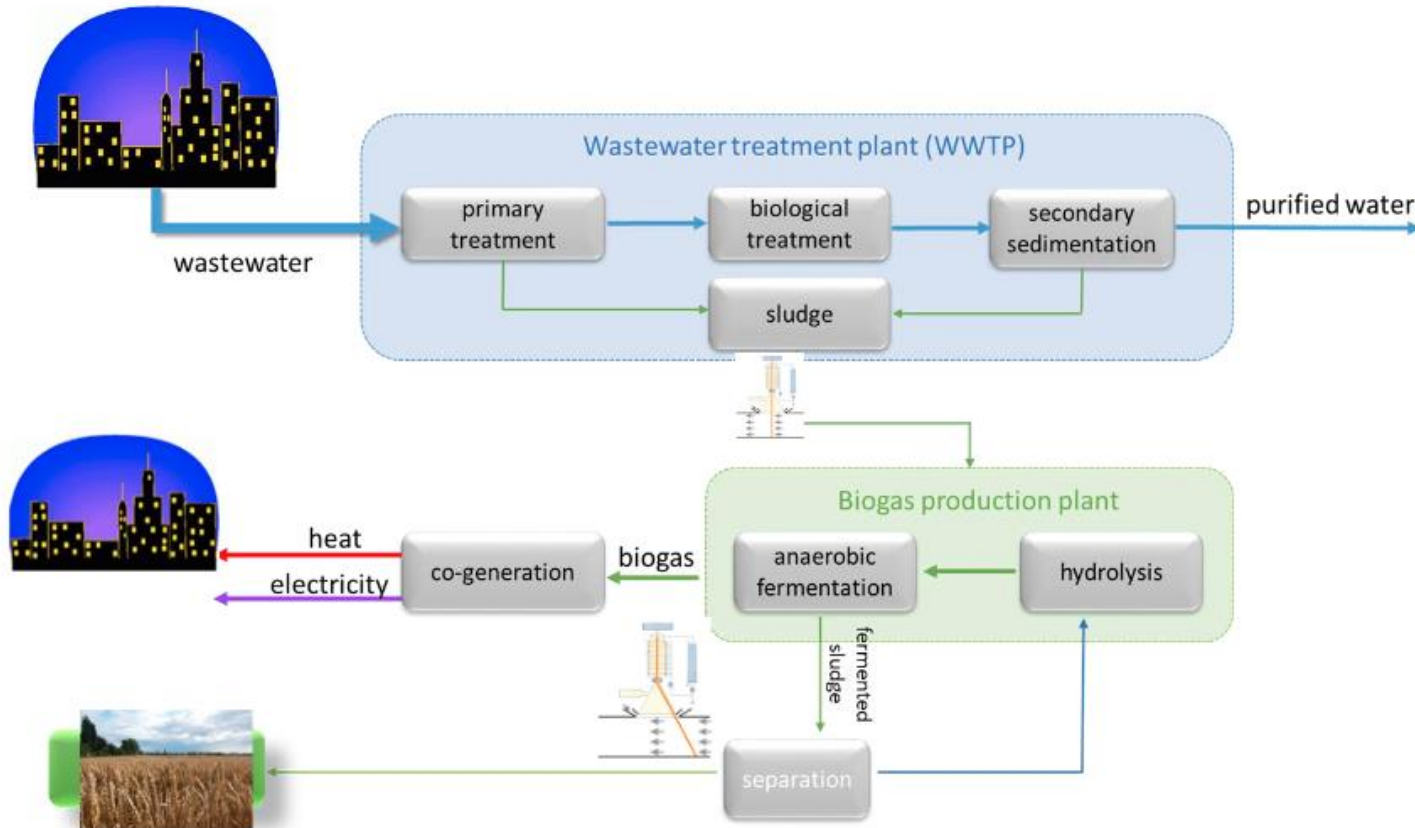

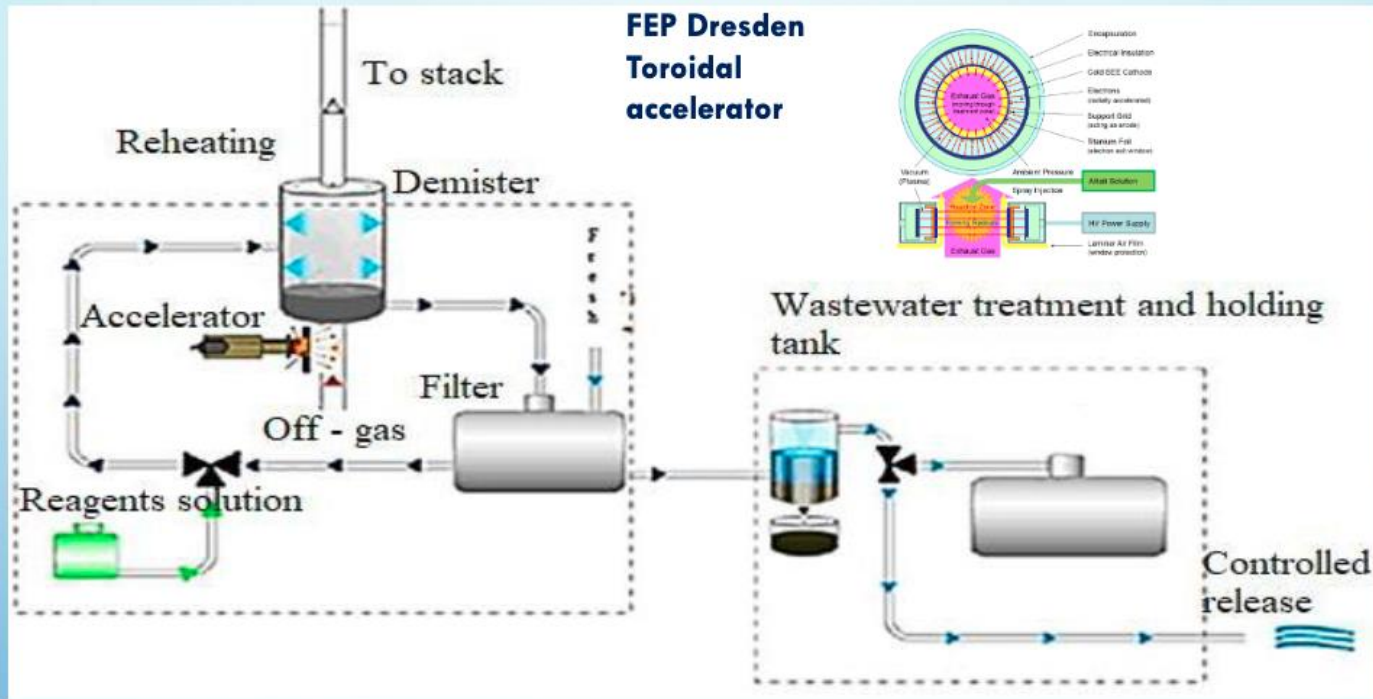

CONCEPTUAL SCHEME OF THE INSTALLATION USING EB TECHNOLOGY FOR SO_x AND NO_x REMOVAL AS APPLIED ON BOARD

Courtesy of Sergey Kutsaev, Radiabeam

Radioisotope sources applications:

- Agricultural applications (enforced mutation, insect sterilization, pre-planting stimulation)
- Non-destructive testing (field radiography, cargo inspection, borehole logging)
- Radiation damage studies (electronics, petroleum, construction materials)
- Medical (blood irradiation, radiotherapy)

Radioisotopes properties:

- Light and inexpensive
- Monochromatic radiation
- Radiate continuously
- Safety issues (accidents, theft, terrorism)

Accelerator-based alternatives:

- Energy spectrum is bremsstrahlung
- Electron energy must be $\sim 3\text{-}4\times$ gamma energy
- **Size and weight must be comparable**
- **Economical: price is a big limiting factor**

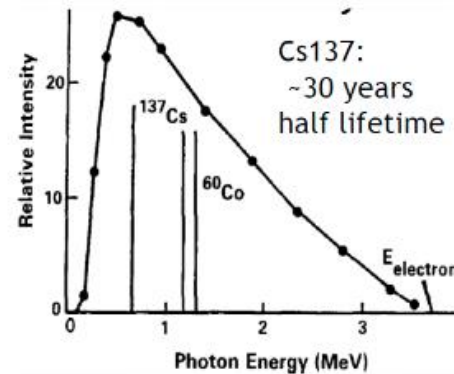

Isotope	Half life	Energy
Yb-169	32 days	145 keV
Se-75	120 days	217 keV
Ir-192	74 days	380 keV
Cs-137	30 y	661 keV
Co-60	5.3 years	1.25 MeV

Industry is producing accelerators to replace radioisotopes.

Courtesy of Anne-Laure Lamure

Cosmic Rays → NPF → CCN → clouds → Global Climate

New Particle Formation Cloud Condensation Nuclei

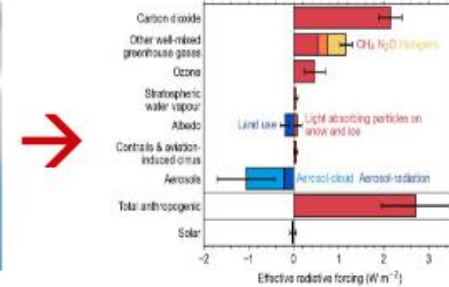
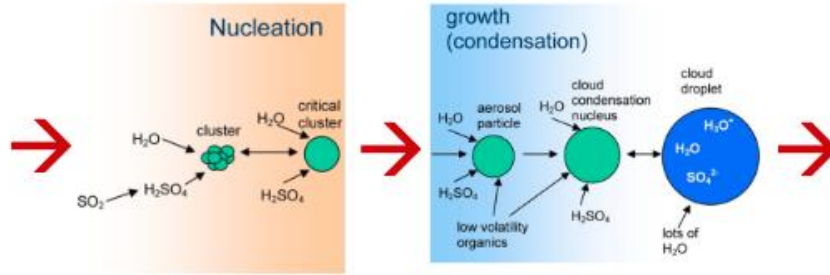
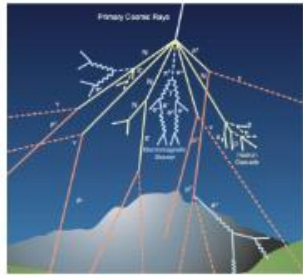

CERN CLOUD Experiment



Credit: Maximilien Brice

Accelerators can be used to study the effect of cosmic rays on cloud formation

Courtesy of Eva Sommer

... and much more



- There are many more applications to accelerators.
- Although HEP is driving the progress other communities have now their types of accelerators.
- As new generations are built, new potentials and new possibilities are discovered.

Ultra compact sources: Laser-driven plasma acceleration (1)

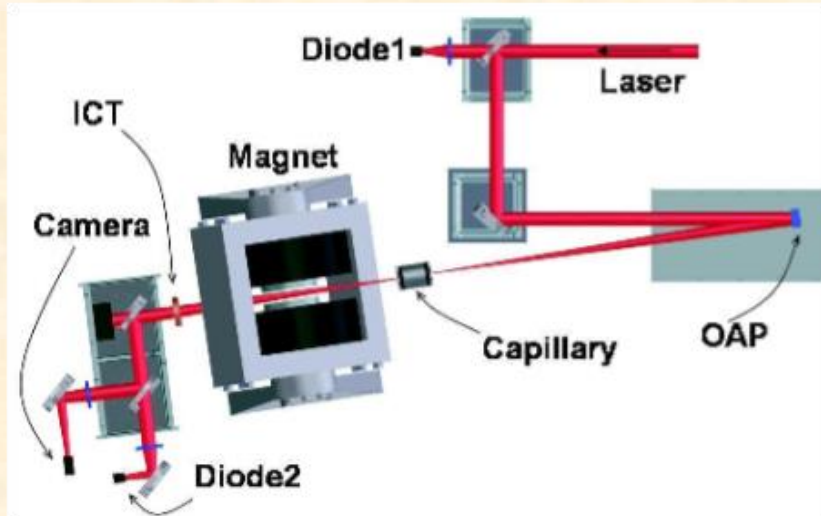

- An intense laser pulse shot in a plasma can accelerate electrons to very high energy: 1 GeV over 33mm
- Such electron source could produce high energy low emittance electron beam over very short distances.
- This could be used to drive a compact FEL.

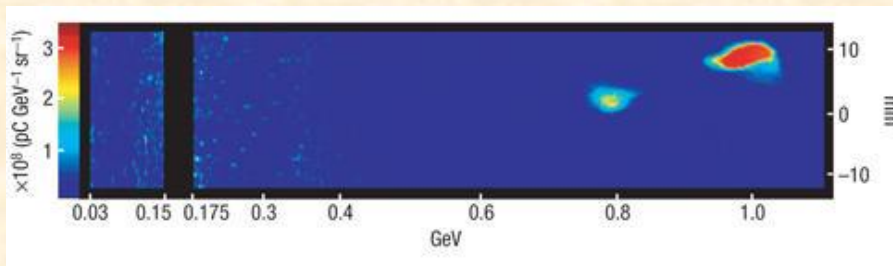

Leemans et al, doi:10.1038/nphys418

Ultra compact sources: Laser-driven plasma acceleration (2)

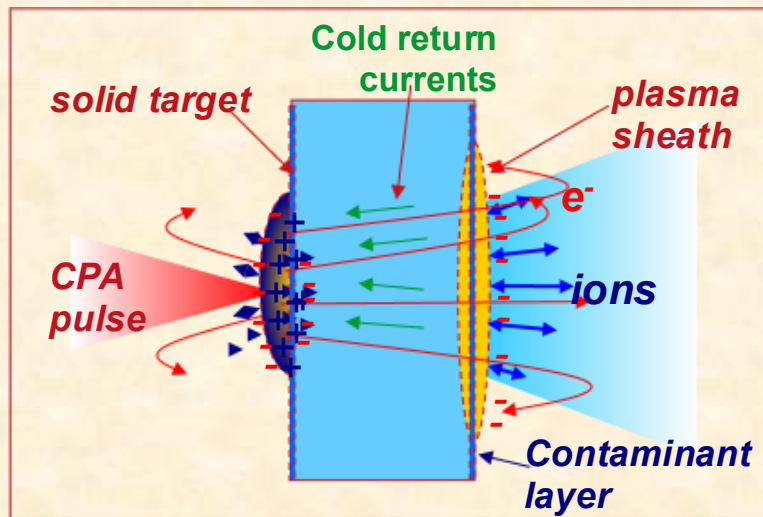

- If a similar laser is shot onto a target, medium energy ions can be produced.
- This could be used for ion therapy.

ThomX

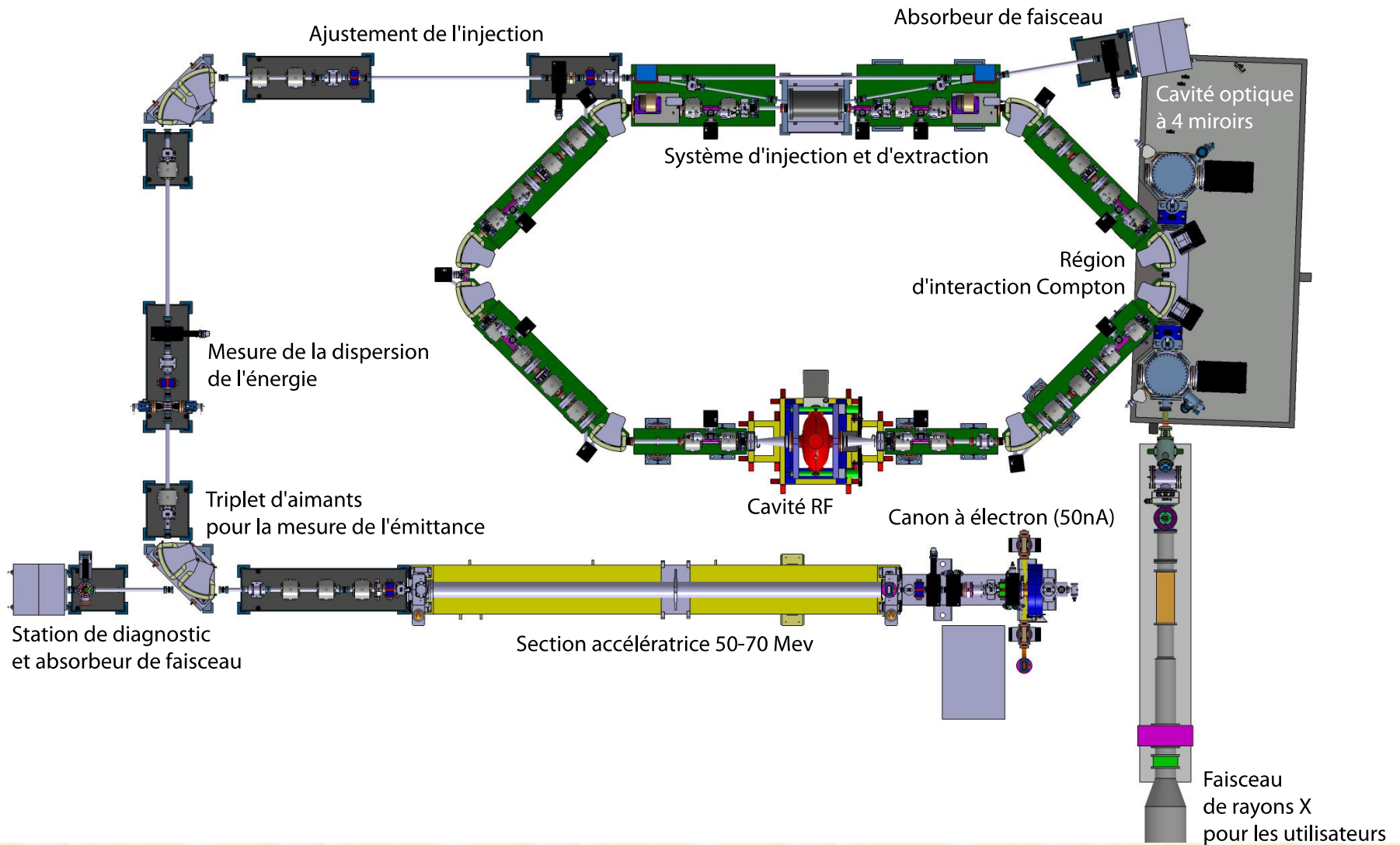

Costs

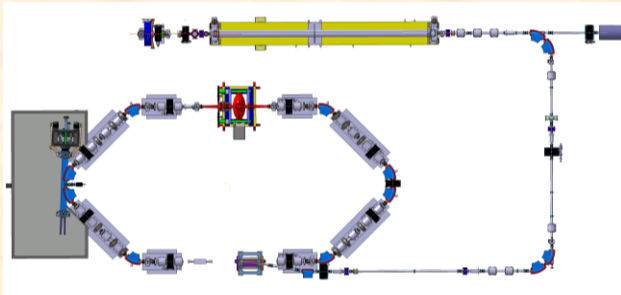
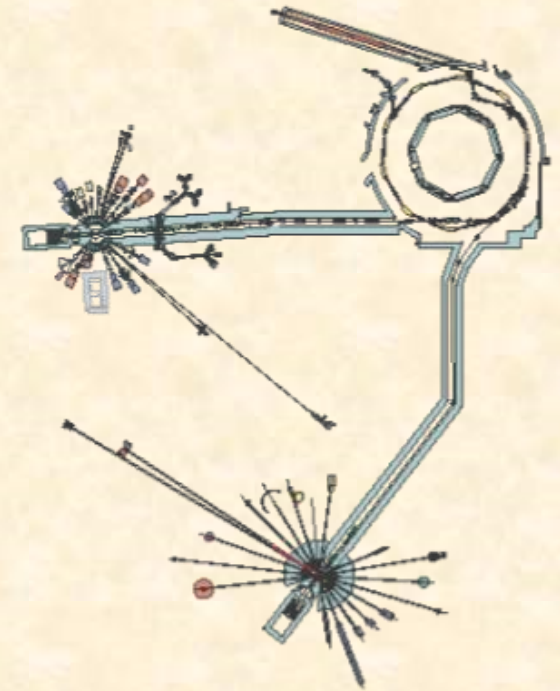

- Small accelerators can be operated by single institutions.
- Large accelerators need to be built as part of international collaborations.



Progress of accelerators

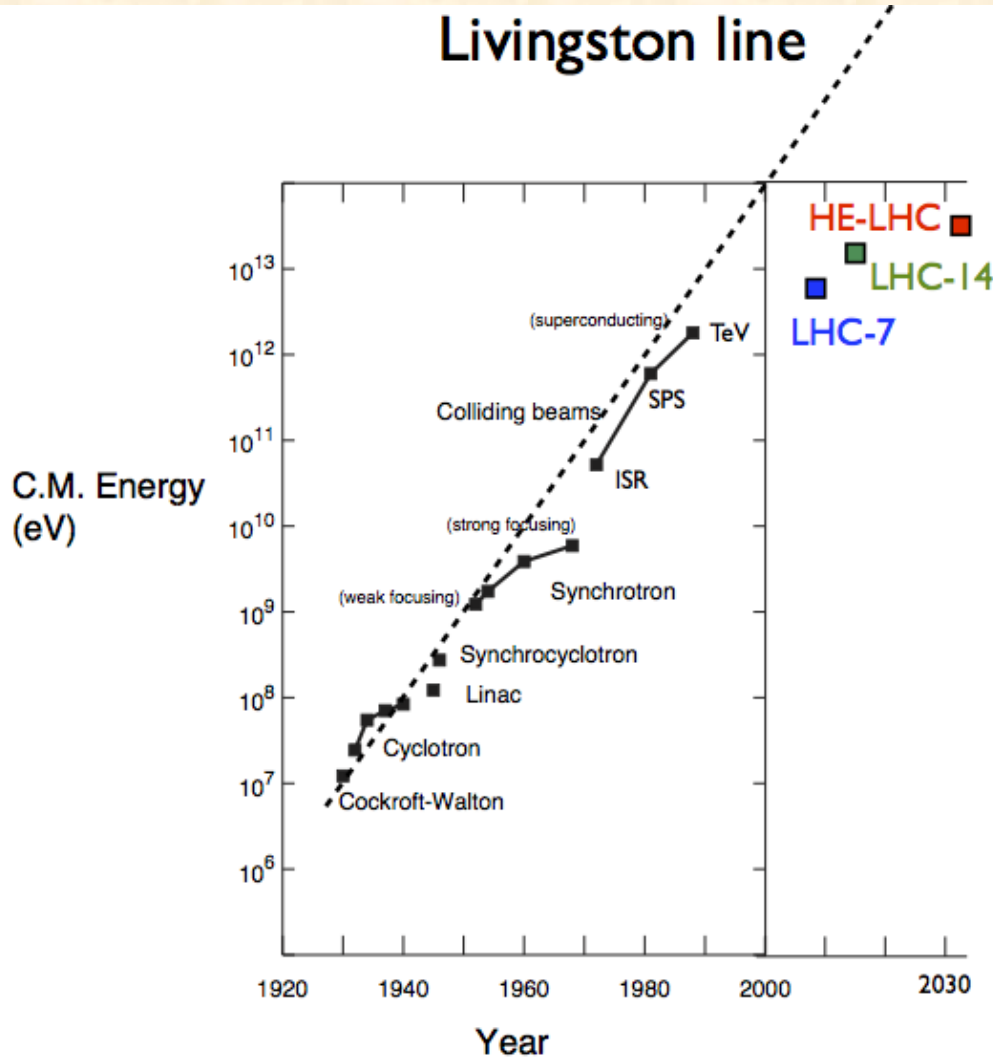

- Accelerators have made tremendous progress over the past 50 years.
- They drove part of the developments of HEP.
- However they have also become very large and expensive.

European Strategy

General Recommendations

- i. *The full exploitation of the physics potential of the LHC and the HL-LHC and the completion of the high-luminosity upgrade remain the highest priorities of European particle physics. Every effort must be made to complete the HL-LHC upgrade within the current schedule.*

CERN's future vision and strategy is completely aligned with this recommendation:

- HL-LHC machine *and* detectors are CERN's highest priorities
- Full exploitation of HL-LHC including LHCb and ALICE upgrades
- Importance of maintaining the current schedule

Recommendations on the next collider at CERN

I. The next CERN flagship collider project

- i. *The electron–positron Future Circular Collider (FCC-ee) is recommended as the preferred option for the next flagship collider at CERN.*
- ii. *A descoped FCC-ee is the preferred alternative option for the next flagship collider at CERN*

OVERALL SUMMARY OF THE LECTURES

Particle sources & acceleration

- Particles are extracted from matter either using ionisation or by creating a plasma.
- They are accelerated using RF fields.
- They are controlled using magnets.

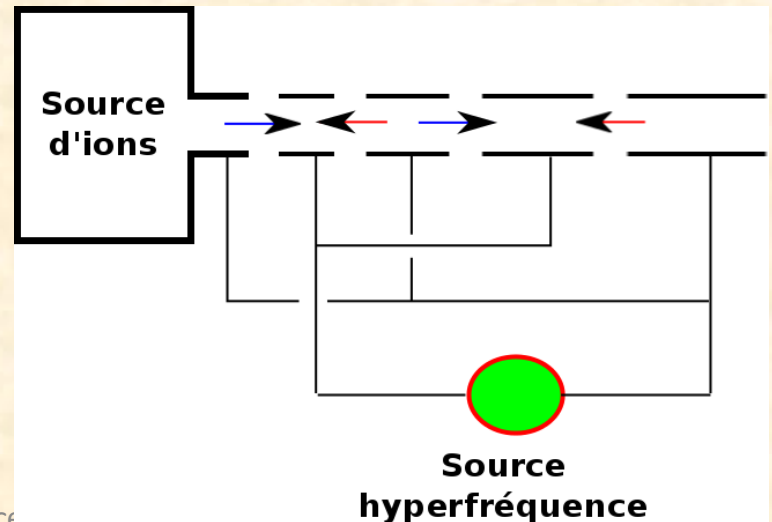
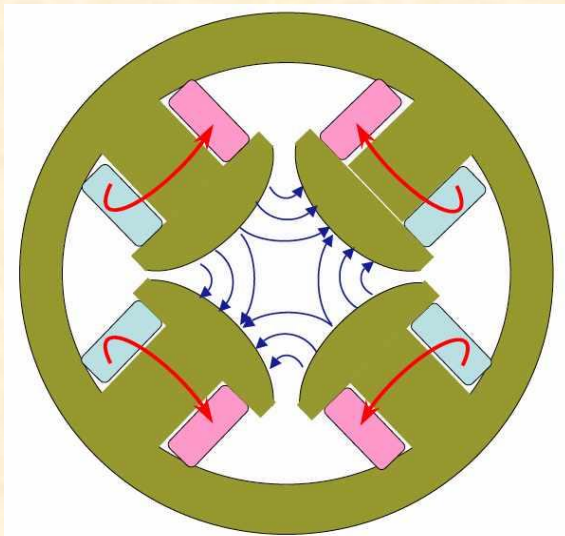
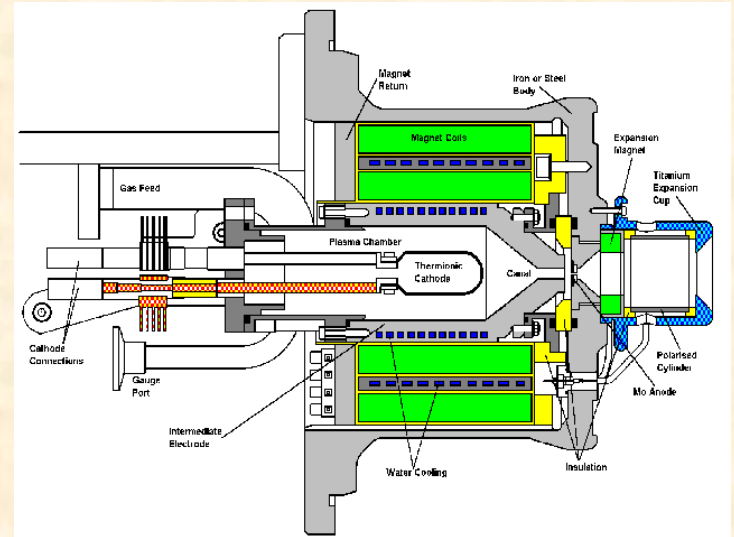

BASIC CONCEPT (RF)

Figure of merit of EM design:

E_{peak} : minimize peak surface electrical field in order to reduce field emission (normalized to E_{acc})

B_{peak} : minimize peak magnetic field to maximize achievable accelerating voltage (normalized to E_{acc})

$\left(\frac{R}{Q}\right)_n = \frac{V_{acc}^2}{\omega_n W_n}$: maximize R/Q to produce more accelerating voltage V_{acc} for a given stored energy W in the cavity

$G = QR_s$: maximize the geometry factor to increase the cavity effectiveness of providing accelerating voltage (shape alone)

Regarding the accelerated particle and the materials (NC or SC), the optimization of RF structures will focus on these parameters

Superconducting magnets is required for high energy or high current applications

- Reduction of radius of curvature and power consumption
⇒ With room temperature magnets, the LHC circumference would be 120 km and the power consumption impossible to handle
- Bigger aperture as $B \propto I_0/\text{aperture}$ for dipole , $I_0/\text{aperture}^2$ for quadrupoles
⇒ Bigger transverse acceptance
⇒ Less beam losses, Less constraints for alignment.

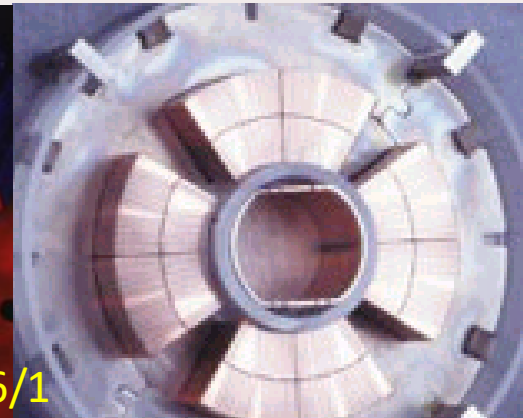
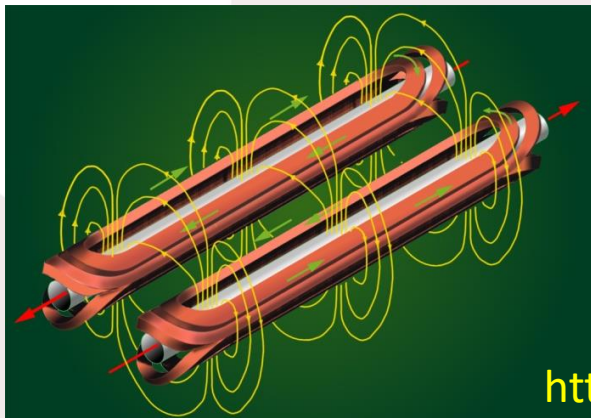

<http://www.lhc-closer.es/1/4/6/1>

Superconducting RF is compulsory for CW high-current operations :

- **for NC, $P_{RF} \propto \omega^{-1/2}$, for SC, $P_{RF} \propto \omega$**
 - ⇒ Lower frequency ⇒ Larger longitudinal acceptance
 - ⇒ Larger structure ⇒ Larger transverse acceptance
 - ⇒ **Reduced beam losses**

- Energy efficiency is better : $P_{cryo} + P_{RF-SC} < P_{RF-NC}$
 - ⇒ For SC cavities $P_{RF-SC} \sim 10W$ ($Q_0 \sim 5E9$) @ 6.4 MV/m
 - For Spoke section : $P_{RF-SC} \sim 400$ kW, $P_{cryo} \sim 600$ kW
 - ⇒ For NC cavities $P_{RF-NC} \sim 185kW$ ($Q_0 \sim 3e5$) @ 6.4 MV/m
 - For Spoke section : $P_{RF-NC} \sim 9$ MW

- Higher accelerating gradient achievable in CW
(in practice... not in theory) as $P_{RF} \propto E_{acc}^2$.
 - ⇒ **Reduced linac length**

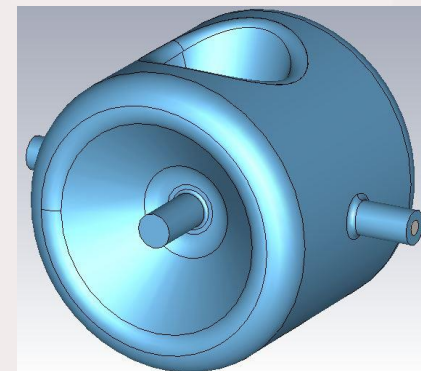

Spoke cavity, 352 MHz

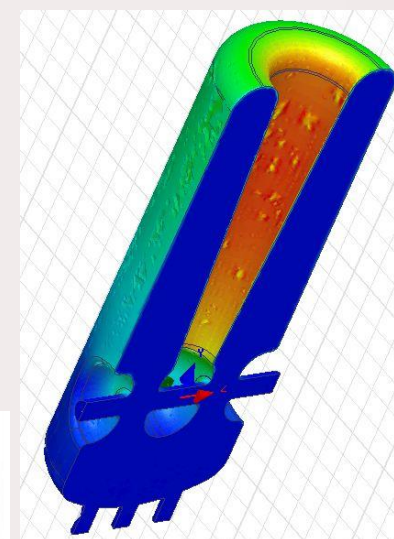

Quarter Wave Resonator,
88 MHz

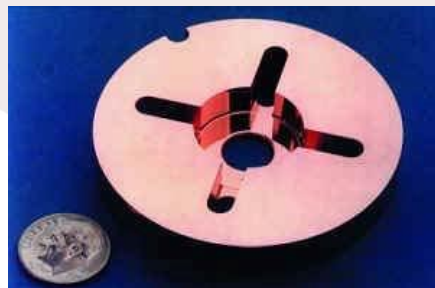

NLC, 11.4 GHz



Elliptical cavity, 1.3 GHz

MAIN COMPONENTS

- ❑ **Vacuum vessel**
 - Thermal Insulation
 - Interface
- ❑ **Supporting components**
 - Supporting and positioning
- ❑ **Thermal shields**
 - Thermal Insulation
- ❑ **Cryogenic piping**
 - Cryogenic environment
- ❑ **Magnetic shield**
 - Magnetic protection
- ❑ **Cold mass (cavities, magnets)**

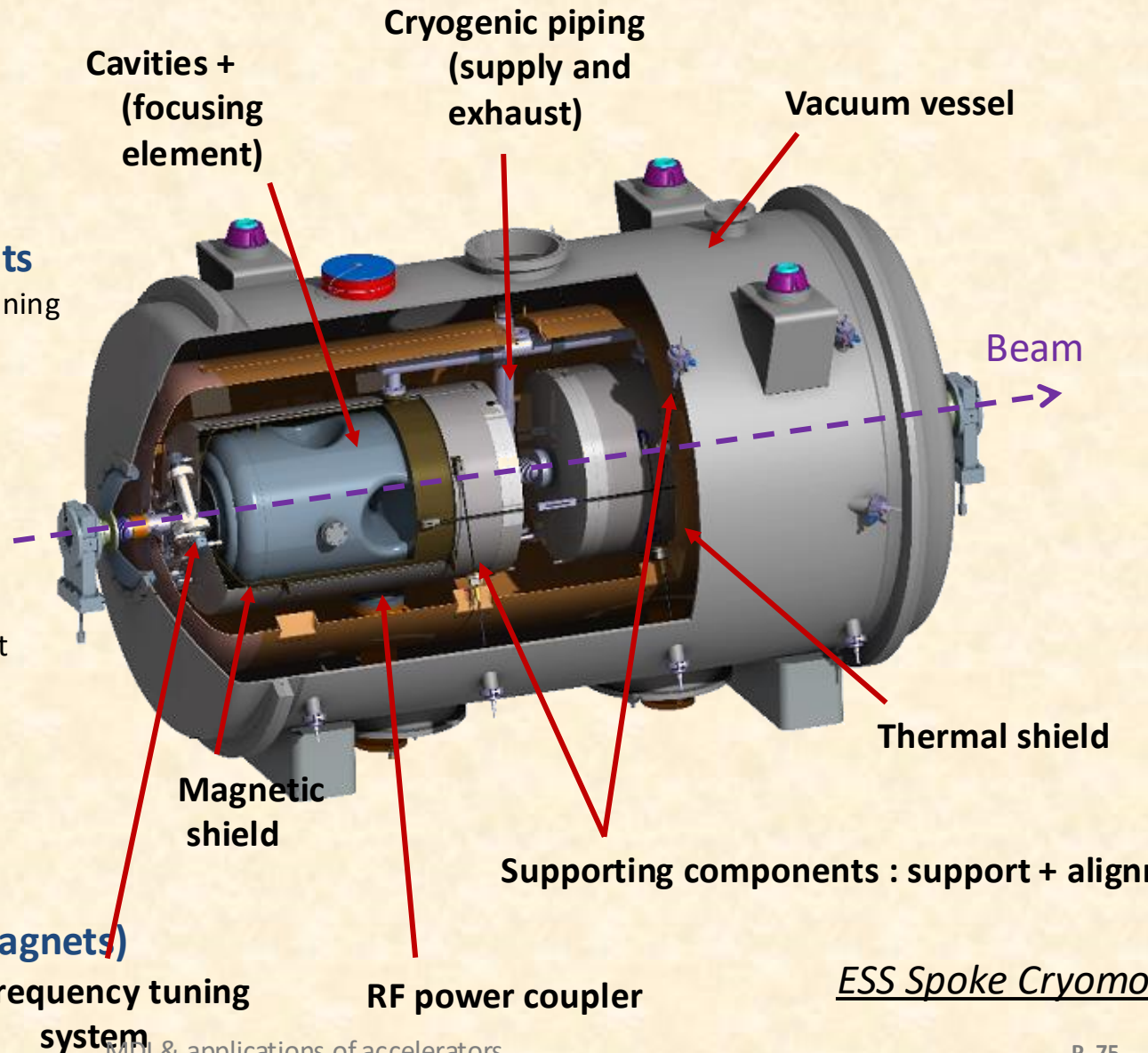

ESS Spoke Cryomodule

Dynamics & diagnostics

- There are many physical phenomena that act on and in the beam.
- Understanding them is important to control and improve beam quality.
- Tools are necessary to be able to visualise them.

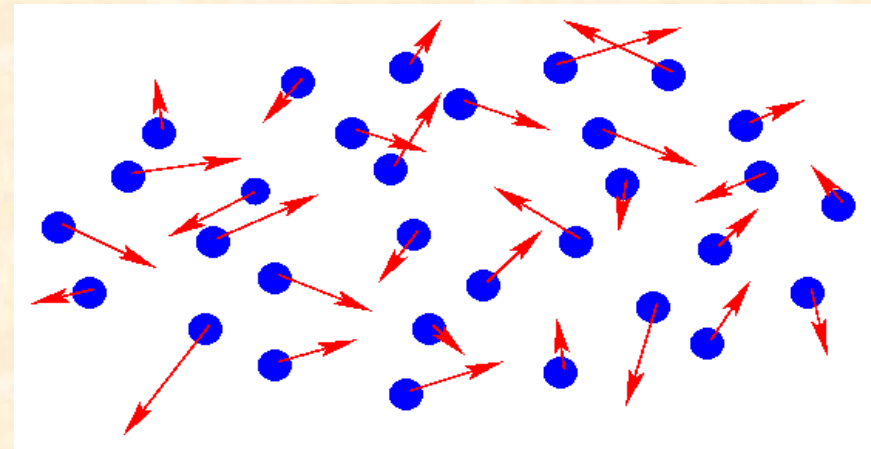

Massive shower in a tungsten cylinder (outlined in green) produced by a single 10 GeV incident electron.

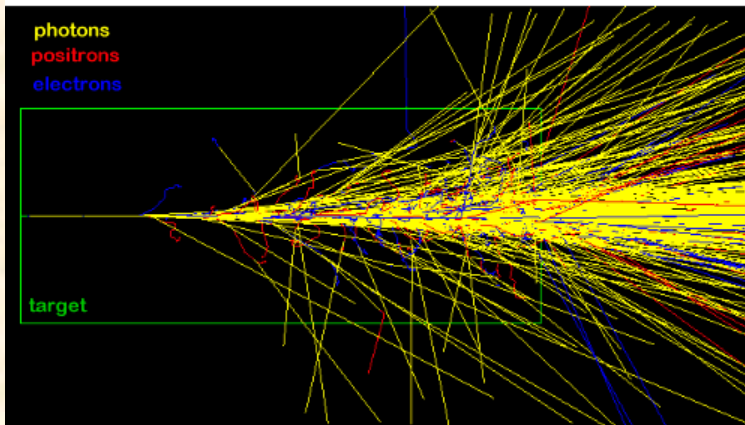

TRANSVERSE BEAM DYNAMICS : SUMMARY

Nicolas Delerue, IAL
Orsay

Charged particle in electromagnetic field : $\frac{d\vec{p}}{dt} = q(\vec{E} + \vec{v} \times \vec{B})$

Cyclotron frequency : $\omega = \frac{qB}{m}$ Magnetic Rigidity $B\rho = \frac{P}{q}$, Electric rigidity $E\rho = \beta c \times B\rho$

Maxwell equations : $div \vec{E} = \frac{\rho}{\epsilon_0}$, $div \vec{B} = 0$, $\overrightarrow{rot} \vec{E} = -\left(\frac{\partial \vec{B}}{\partial t}\right)$, $\overrightarrow{rot} \vec{B} = \mu_0 \vec{J} + \frac{1}{c^2} \frac{\partial \vec{E}}{\partial t}$

Maximum B achievable in iron at room temperature $\sim 1.8T$, for high B need supra !

In bending magnet : Ampère-turn $NI \approx g \frac{B}{\mu_0}$, in quadrupole : $NI \approx \frac{R^2}{2} \frac{G}{\mu_0}$

Quadrupole focal length : $f = \frac{B\rho}{GL}$

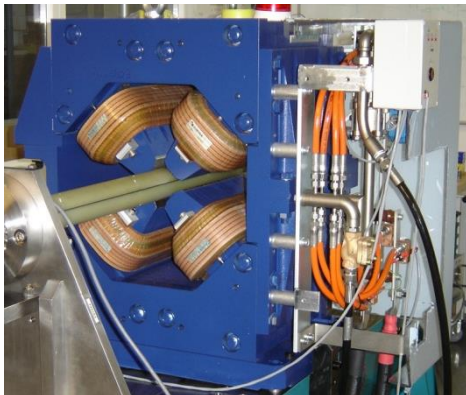

General development of magnetic field around the reference trajectory:

$$\begin{cases} B_x(s) = h^{-1} B_{z0} (-nh^2 z + 2\beta h^3 xz + \dots) \\ B_z(s) = h^{-1} B_{z0} (h' z - (n'h^2 + 2nhh' + hh') xz + \dots) \\ B_z(s) = h^{-1} B_{z0} \left(h - nh^2 x + \beta h^3 x^2 - \frac{1}{2} (h' - nh^3 + 2\beta h^3) z^2 + \dots \right) \end{cases}$$

Field index : $n = -\frac{\rho}{B_{z0}} \left(\frac{\partial B_z}{\partial x} \right)_0$

Sextupolar : $\beta = \frac{\rho^2}{2B_{z0}} \left(\frac{\partial^2 B_z}{\partial x^2} \right)_0$

Particles motion : Hill's equation $y'' + K_x(s)y = f(s)$ with $y = x$ or z

1st order Bend Matrix (with $L = \rho\theta$) $T = \begin{pmatrix} \cos \theta & \rho \sin \theta & \rho(1 - \cos \theta) \\ -\sin \theta / \rho & \cos \theta & \sin \theta \\ 0 & 0 & 1 \end{pmatrix}$

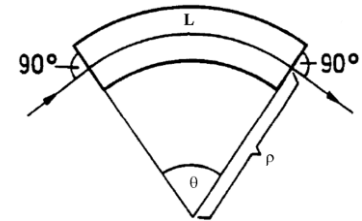

1st order Quadrupole matrix (with $K = \frac{G}{B\rho}$ et $\varphi = \sqrt{K}L$) $T_x = \begin{pmatrix} \cos \varphi & \sin \varphi / \sqrt{K} \\ -\sqrt{K} \sin \varphi & \cos \varphi \end{pmatrix}$ et $T_x = \begin{pmatrix} \cosh \varphi & \sinh \varphi / \sqrt{K} \\ \sqrt{K} \sinh \varphi & \cosh \varphi \end{pmatrix}$

Beam envelop and emittance : $\gamma_y y^2 + 2\alpha_y y' y + \beta_y y'^2 = \epsilon_y / \pi$

Liouville theorem : $\epsilon_y \text{norm} = \beta \gamma \epsilon_y \text{geom} = \text{constante}$

Beam Matrix $\sigma = \frac{\epsilon_y}{\pi} \begin{pmatrix} \beta_y & -\alpha_y \\ -\alpha_y & \gamma_y \end{pmatrix}$ with $\beta_y \gamma_y - \alpha_y^2 = 1$

Transformation : $\sigma_1 = T \sigma_0 T^t$

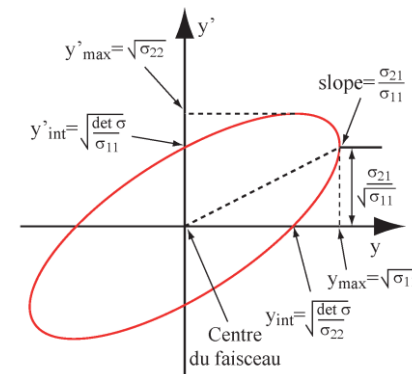

Longitudinal dynamics: Trajectories in the longitudinal phase space (3)

Trajectories for a 60° synchronous phase (sinus « ring-convention ») and $\eta > 0$
(-30° in cosinus « linac-convention »)

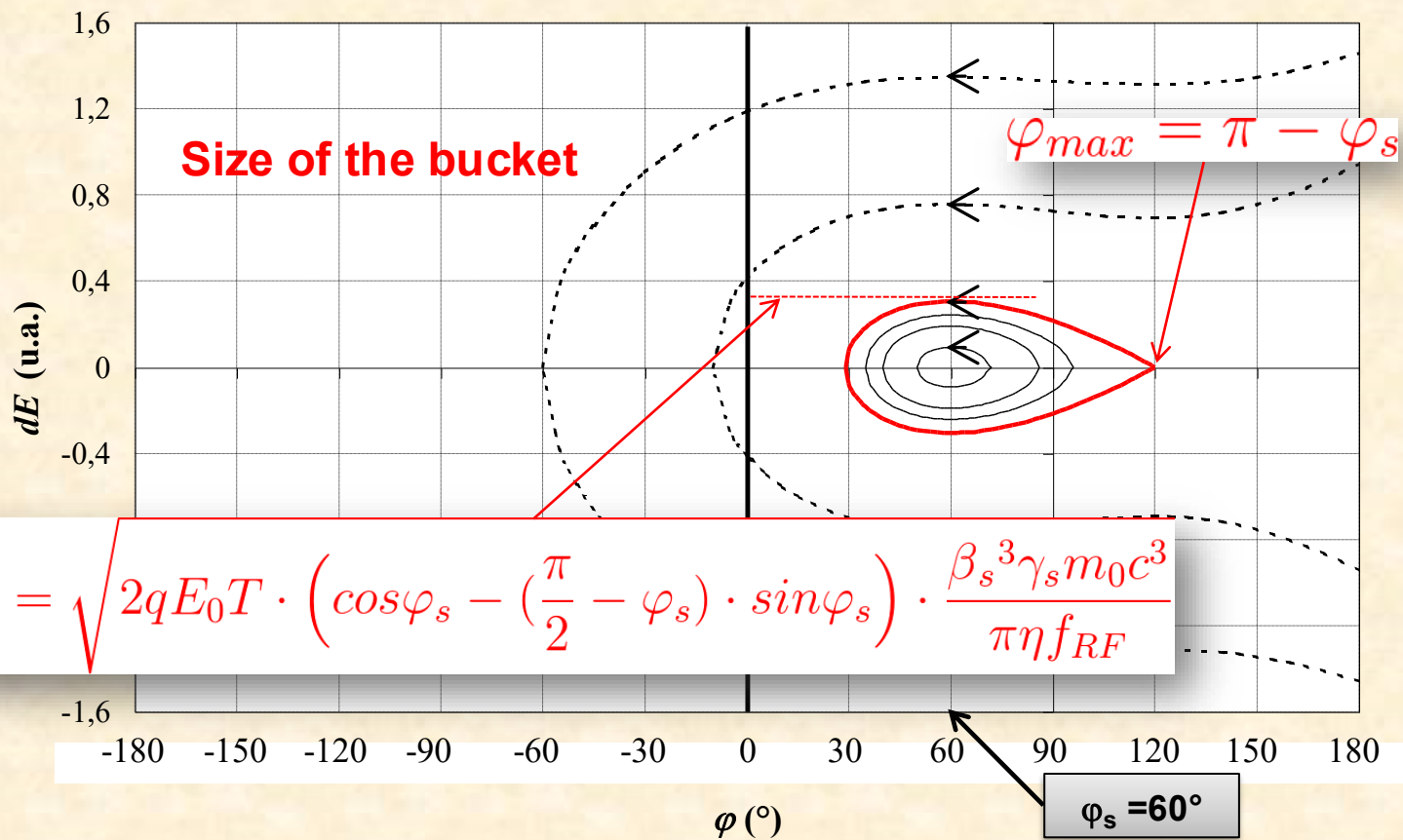

Longitudinal dynamics: Filamentation in longitudinal phase space

All the beam particles are thus traveling on the $H = C^{\text{st}}$ curves in the (ϕ, w) space

= trajectories at frequency k_0 if the forces are linear (inner bucket)

= trajectories at lower frequency when the forces become non-linear (outer bucket)

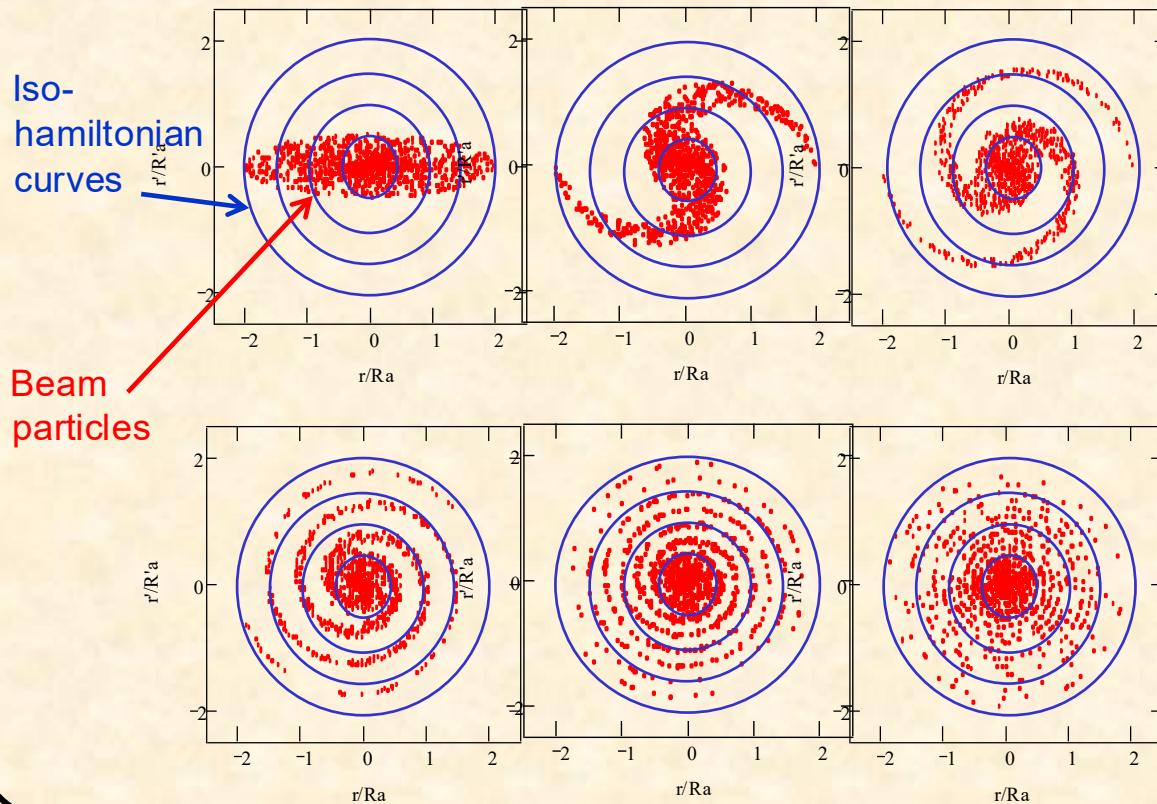

=> If the beam is not correctly matched to $H=cte$ curves, **filamentation** is quickly observed

The beam longitudinal rms emittance is then increasing

peak performance through the years

	2010	2011	2012	Nominal
bunch spacing [ns]	150	50	50	25
no. of bunches	368	1380	1380	2808
beta* [m] ATLAS and CMS	3.5	1.0	0.6	0.55
max. bunch intensity [protons/bunch]	1.2×10^{11}	1.45×10^{11}	1.7×10^{11}	1.15×10^{11}
normalized emittance [mm-mrad]	~2.0	~2.4	~2.5	3.75
peak luminosity [cm ⁻² s ⁻¹]	2.1×10^{32}	3.7×10^{33}	7.7×10^{33}	1.0×10^{34}

>2x design when scaled to 7 TeV!
MDI & applications of accelerators

And wednesday...

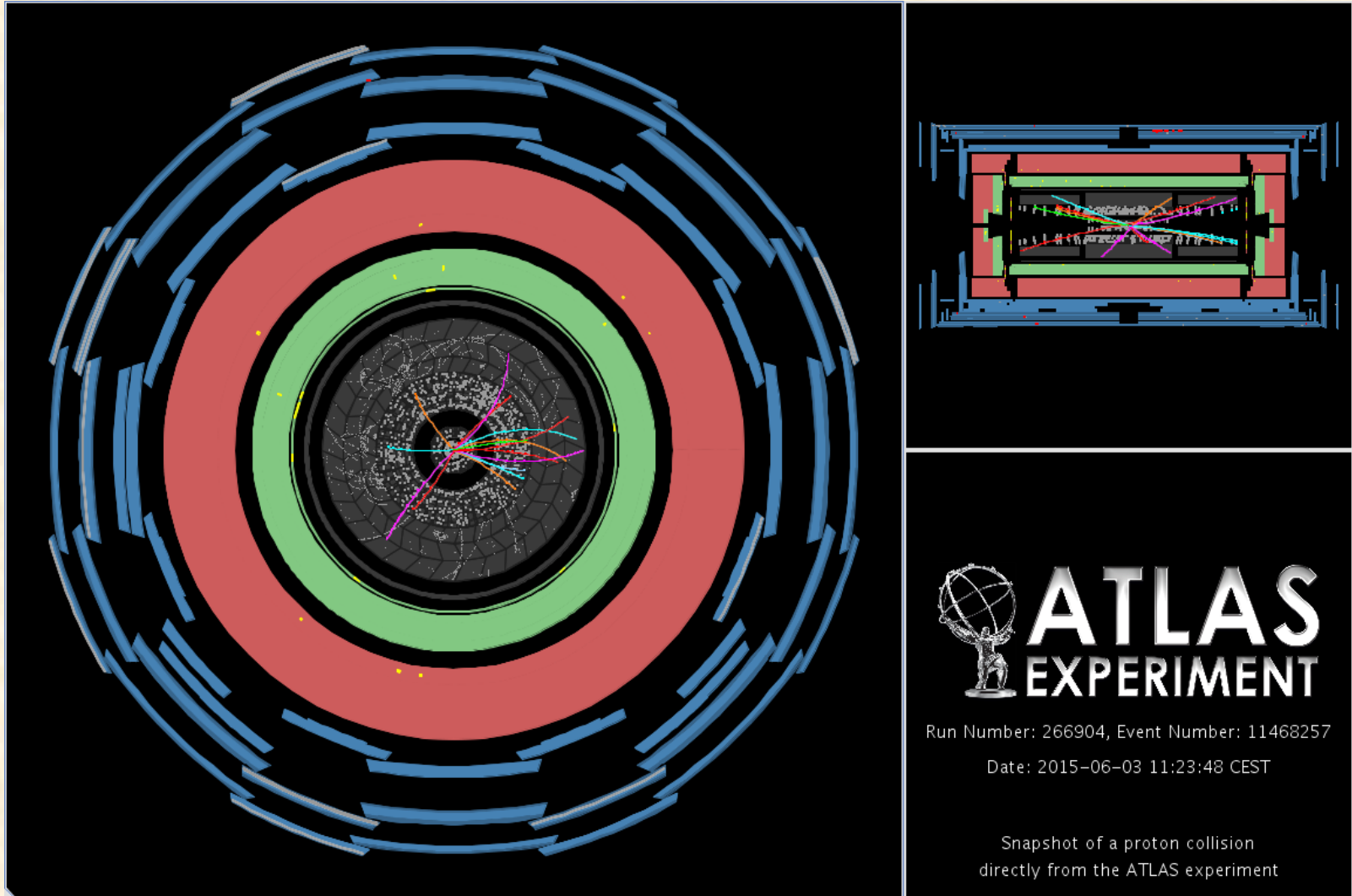

The first physics events of run 2 were recorded!

L'installation SPIRAL2 @GANIL

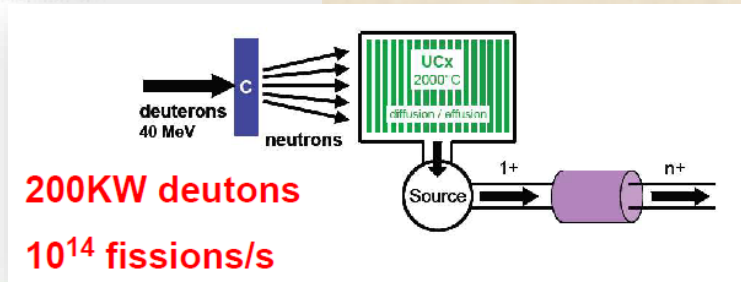
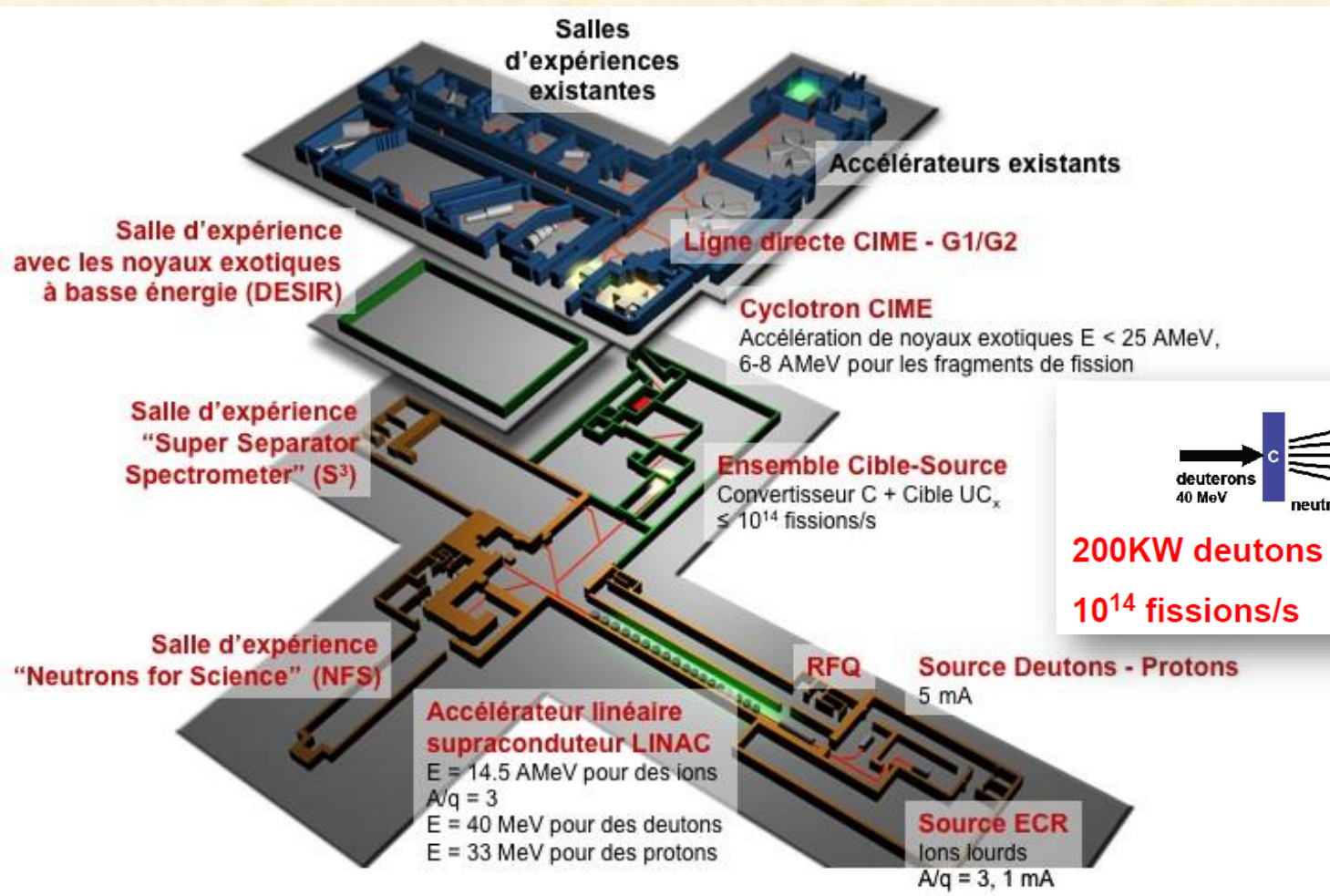

The ISOL method (Isotope On-Line) to produce Rare Isotope Beams

outgassing

Outgassing is the **spontaneous** evolution of gas from solid or liquid.

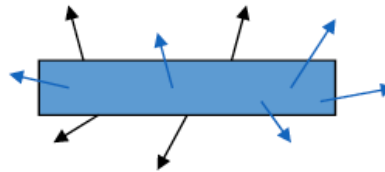
desorption /degazing

Desorption is the release of adsorbed chemical species from the surface of a solid or liquid.

Particules (ions, photons, electrons,....)

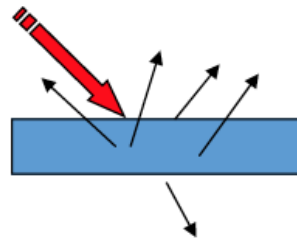

Vacuum in accelerators :

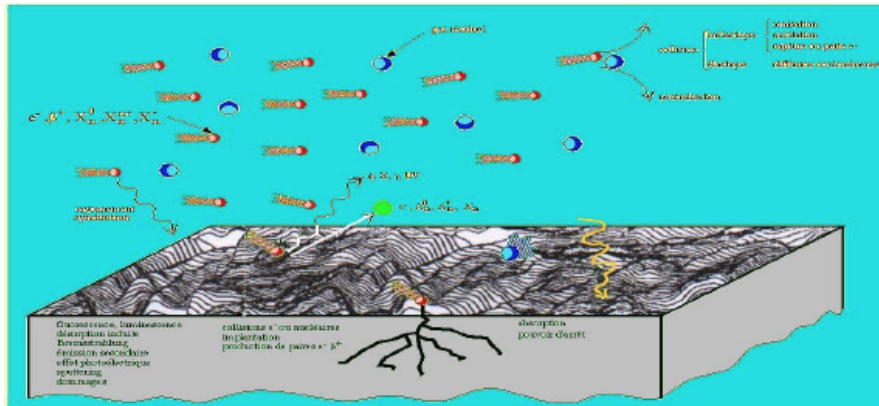

**Beam & Vacuum & Surface:
a difficult coexistence!**

Interaction: Beam - résiduel gas

- ➡ Changing the shape and the beam energy
- ➡ Secondary particle emission (ion, e-, photons)
- ➡ Loss of beam particles

Interaction: Particules (secondary, primary) - surface

- ➡ Desorption by electron, photon, ion impact
- ➡ Secondary emission

Applications of accelerators



Outlook

- Accelerators have a very wide range of applications both for research but also for the industry and medical treatment.
- They range in size from a few meters to several kilometers.
- Their operation and development requires skills from several different fields.

