



Multiplexed
Survey
Telescope
宽视场巡天望远镜



清华大学
Tsinghua University

Multiplexed Survey Telescope

Project Introduction & Collaboration Policy

Eric Jullo / LAM

based on Song Huang slides

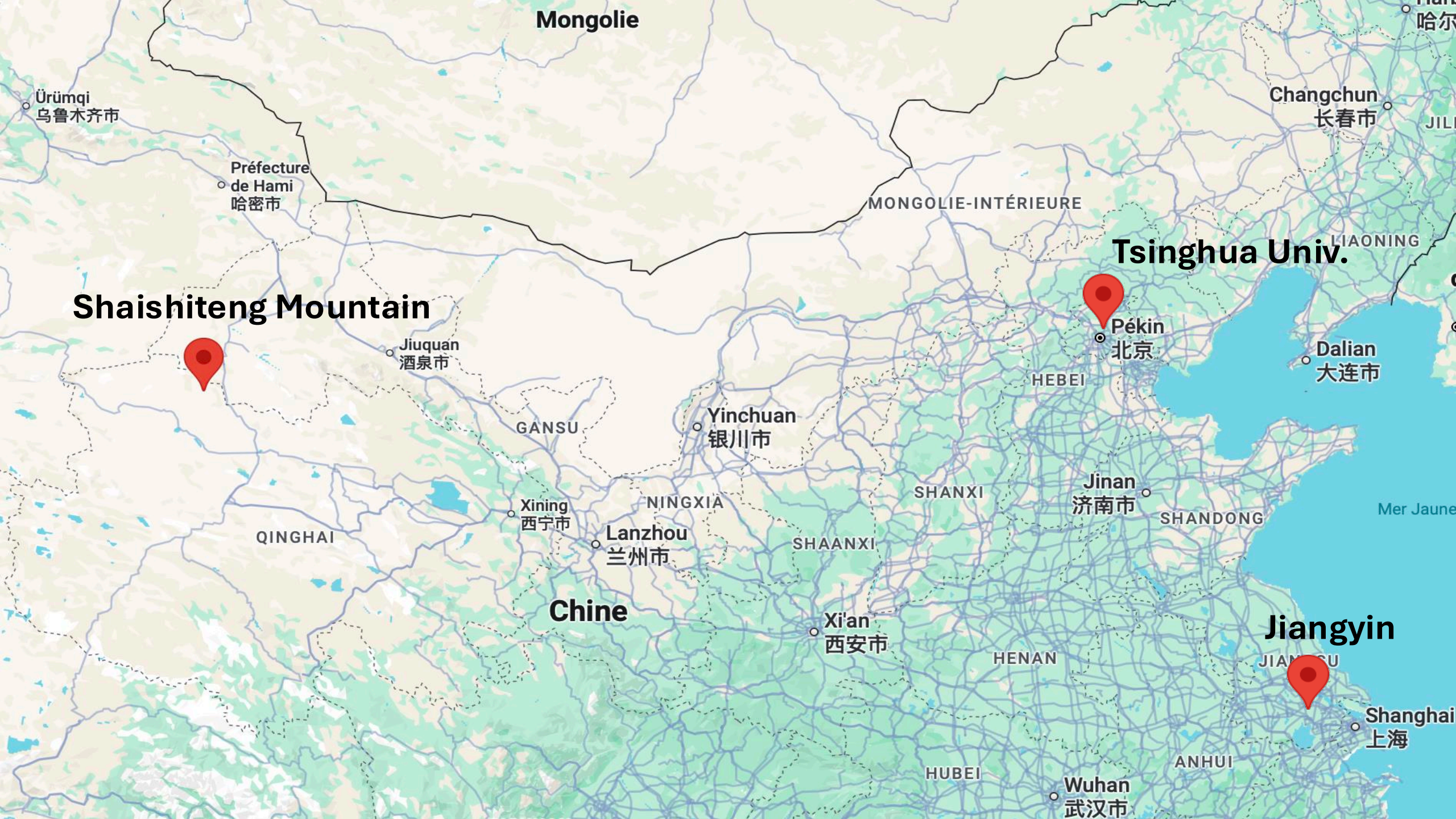

Mongolie

Ürümqi
乌鲁木齐市

Préfecture
de Hami
哈密市

Changchun
长春市

MONGOLIE-INTÉRIEURE

Tsinghua Univ.

Shaishiteng Mountain



Jiuquan
酒泉市



Pékin
北京

Dalian
大连市

GANSU

Yinchuan
银川市

HEBEI

QINGHAI

Xining
西宁市

NINGXIA

Lanzhou
兰州市

SHANXI

Jinan
济南市

SHANDONG

Mer Jaune

Chine

SHAANXI

Xi'an
西安市

HENAN

Jiangyin

JIAN SU

Shanghai
上海

HUBEI

Wuhan
武汉市

ANHUI



The 15th Five-Year Plan

On International Collaboration in Science

“构建高水平科技开放合作新格局”；

Build a new framework for **high-level open scientific** and technological cooperation

“支持与各国科研人员共同攻克基础前沿科学问题”；

Support **joint efforts** with researchers from around the world to **tackle frontier problems** in basic science

“扩大科技计划对外开放”；

Further **open up science and technology programs to international participation**

“推动重大科研基础设施和平台向全球科学家开放使用”；

Promote open access to major research infrastructures and platforms for scientists worldwide

“牵头实施并积极参与国际大科学计划和大科学工程”；

Lead and actively participate in **international large-scale research programs and major science projects**

“支持在我国境内设立国际科技组织”。

Support the establishment of **international scientific and technological organizations** in China



What is MUST?

•Cheng ZHAO, et al. 2024

6.5m
Primary

2.4m Secondary

1.6m Lens WFC

6 deg² FoV

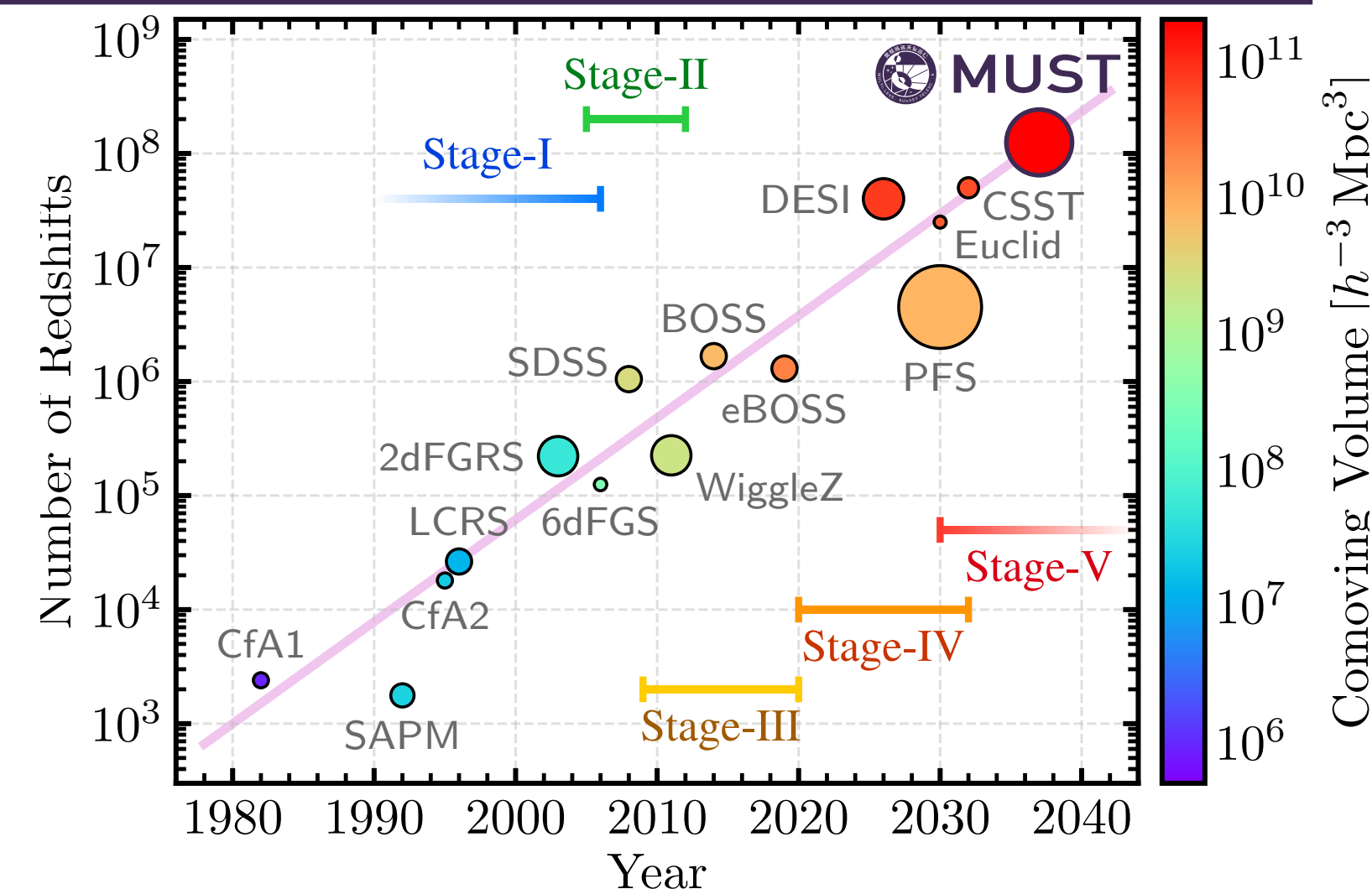
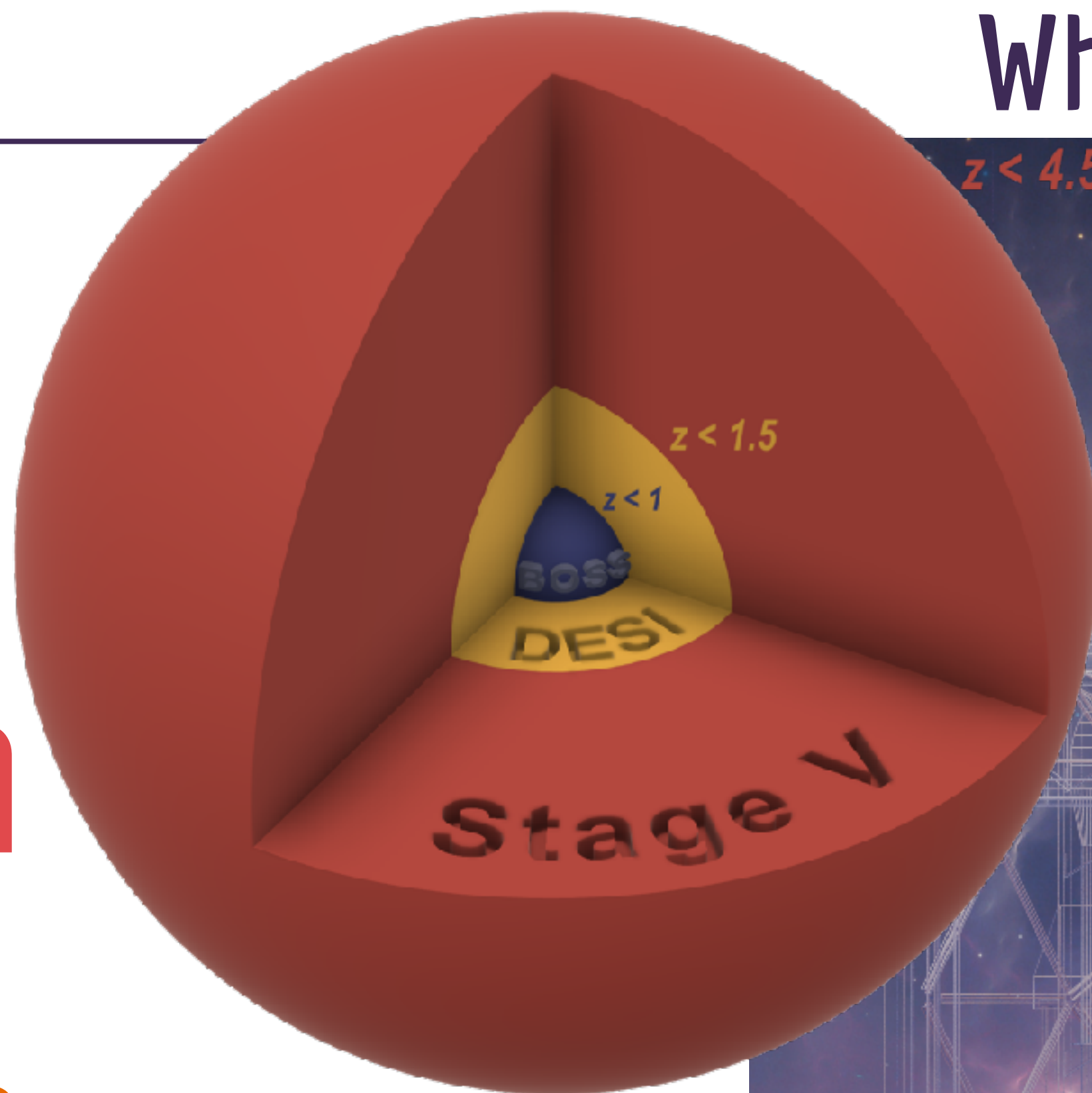

20,000 Fiber Positioners
MODULAR Focal Plane

40 Spectrographs

0.37–0.96 micron

R~2000–5000





A Few Key Numbers

1st 6-m Class Telescope in China

\$230M Estimated Total Cost

~\$140M Raised & Spent

4350m Altitude



July 2026
Construction Begins

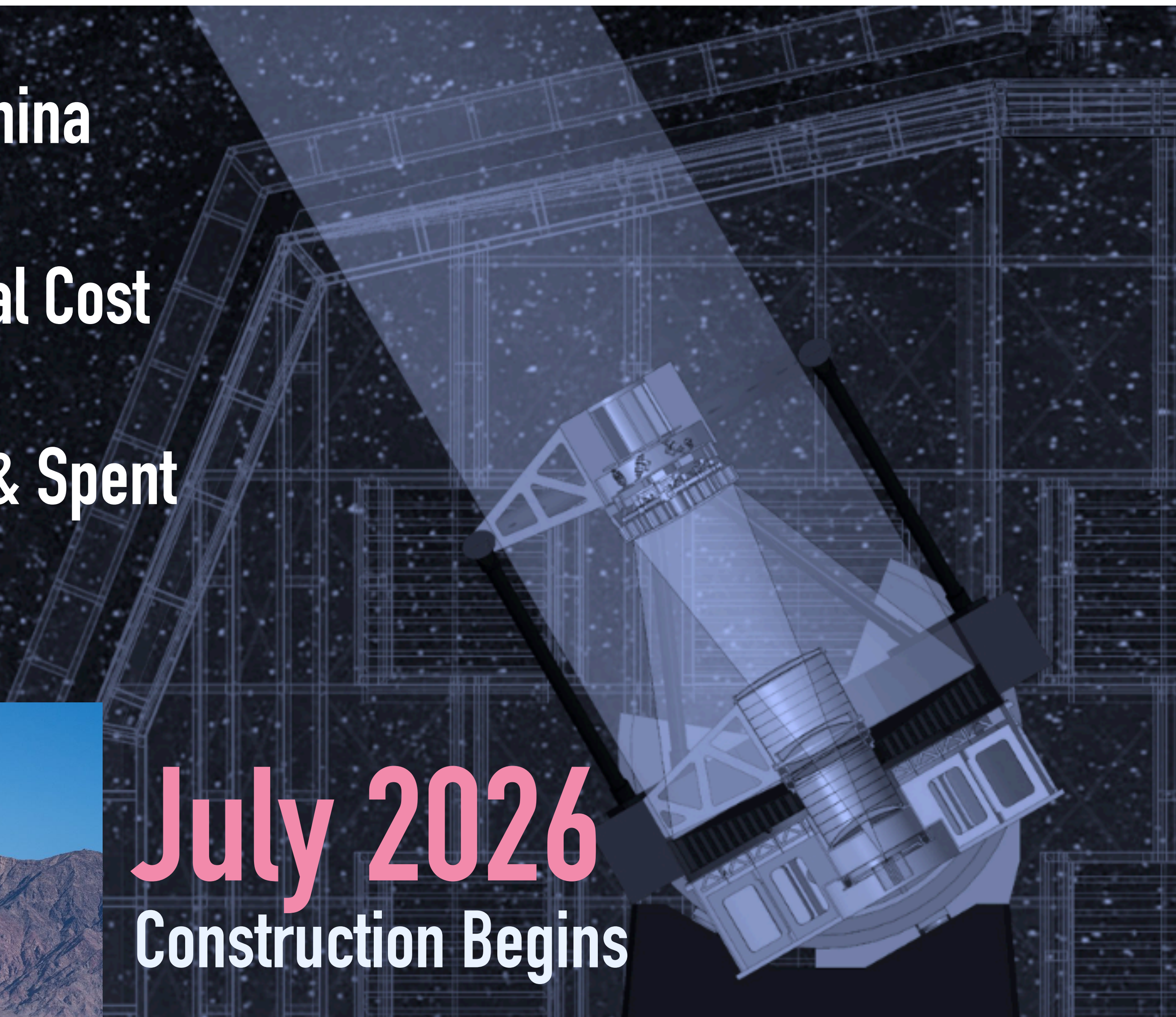



Scientific Roadmap & Requirements

•Submitted the LSS Cosmology Forecast Paper

•Cheng ZHAO, et al. 2024

•Develop the conceptual Grey & Dark night survey

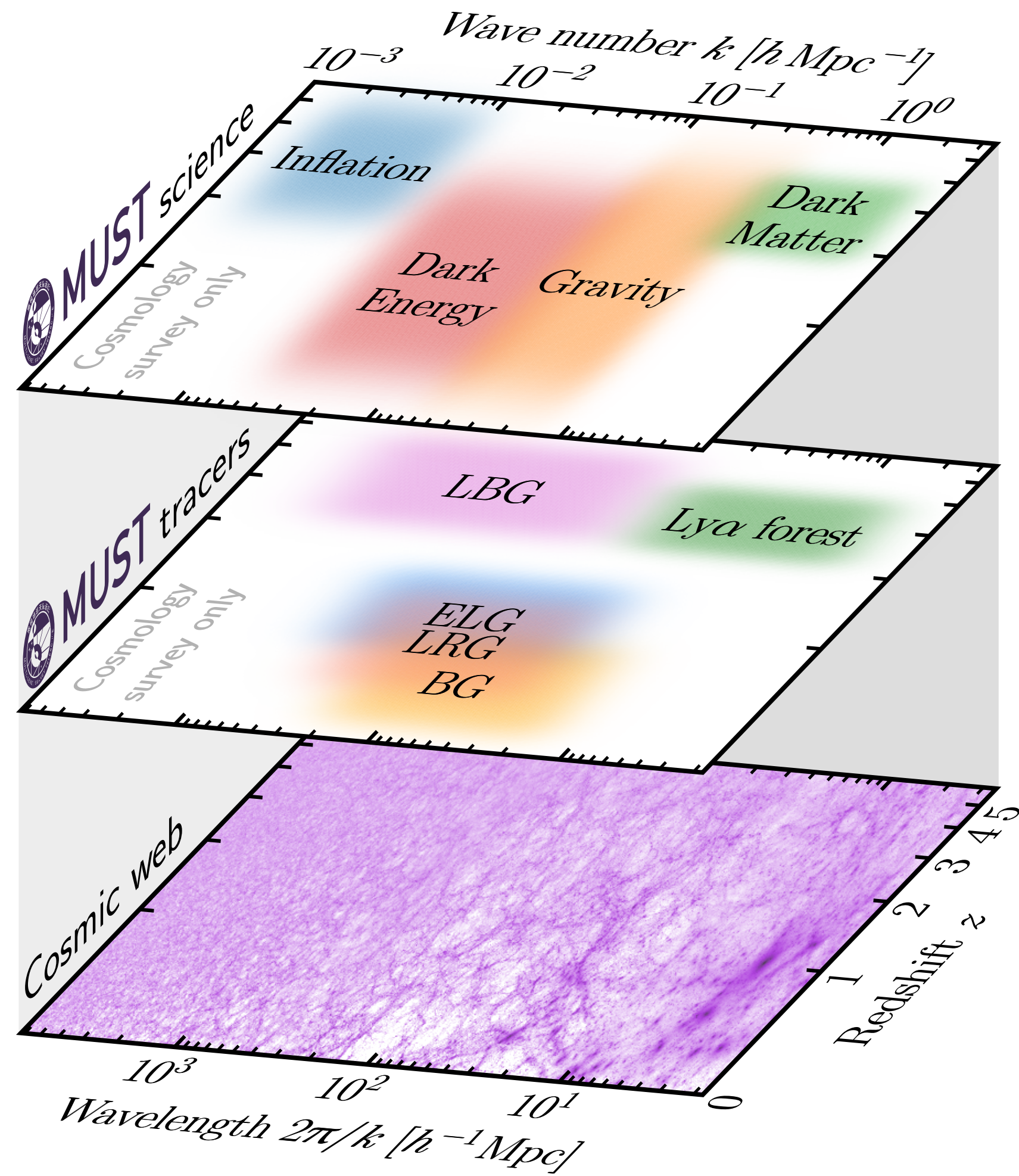

MUST GRAY TIME

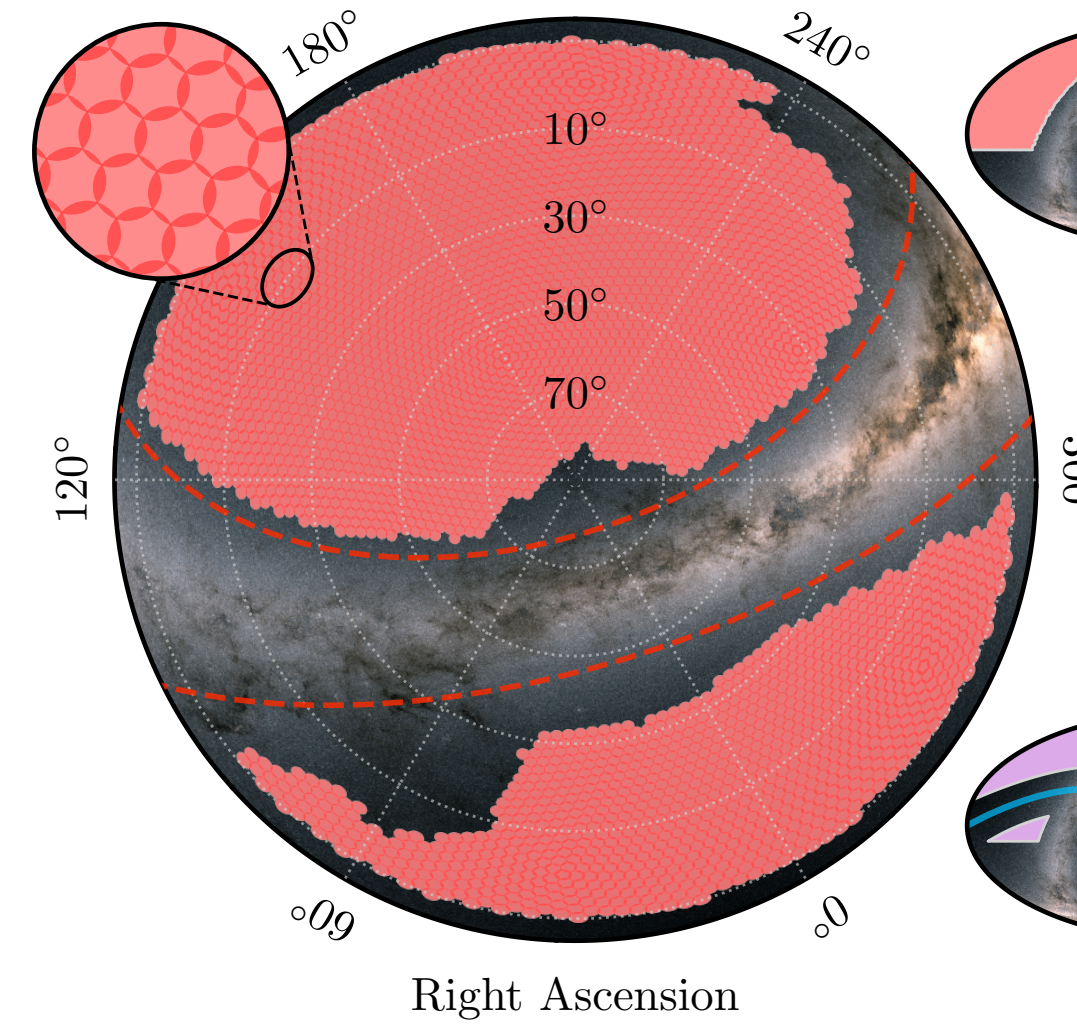

MUST DARK TIME

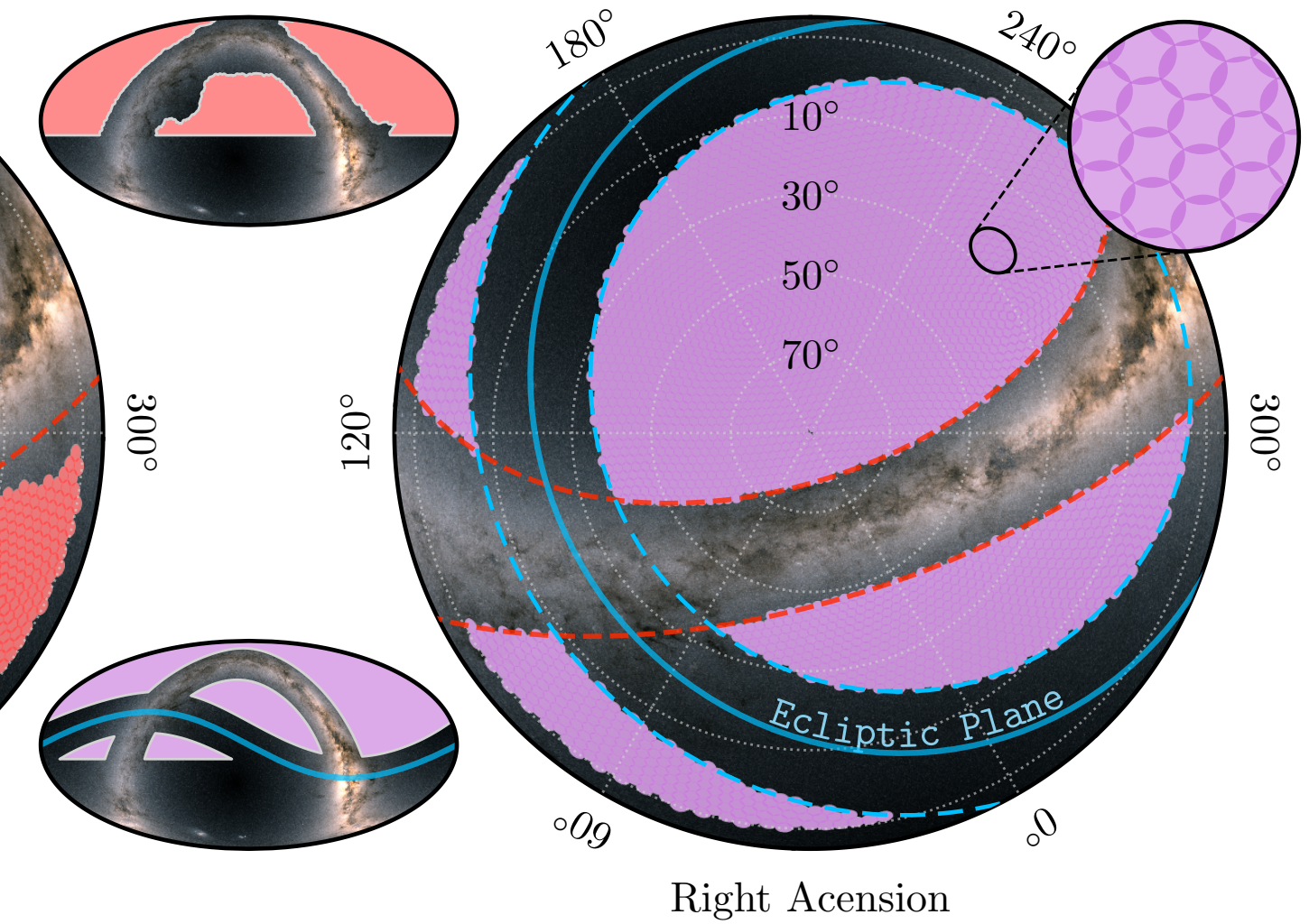

Dark Night

•8.5 Years: -11,000 deg²; -30 Million redshifts of 2.2<z<5.0 LBGs with a 70% redshift success rate & 80% survey efficiency.

Grey Night

•9.5 Years: -13,000 deg²; -114 Million redshifts of z<1.6 BGS/ELG/LRGs with an 80% redshift success rate & 80% survey efficiency.

Overall

•>140 Million redshifts at z<5.0 in the 1st decade of operation for cosmology and extragalactic science



Cosmological constraints

Cheng ZHAO, et al. 2024

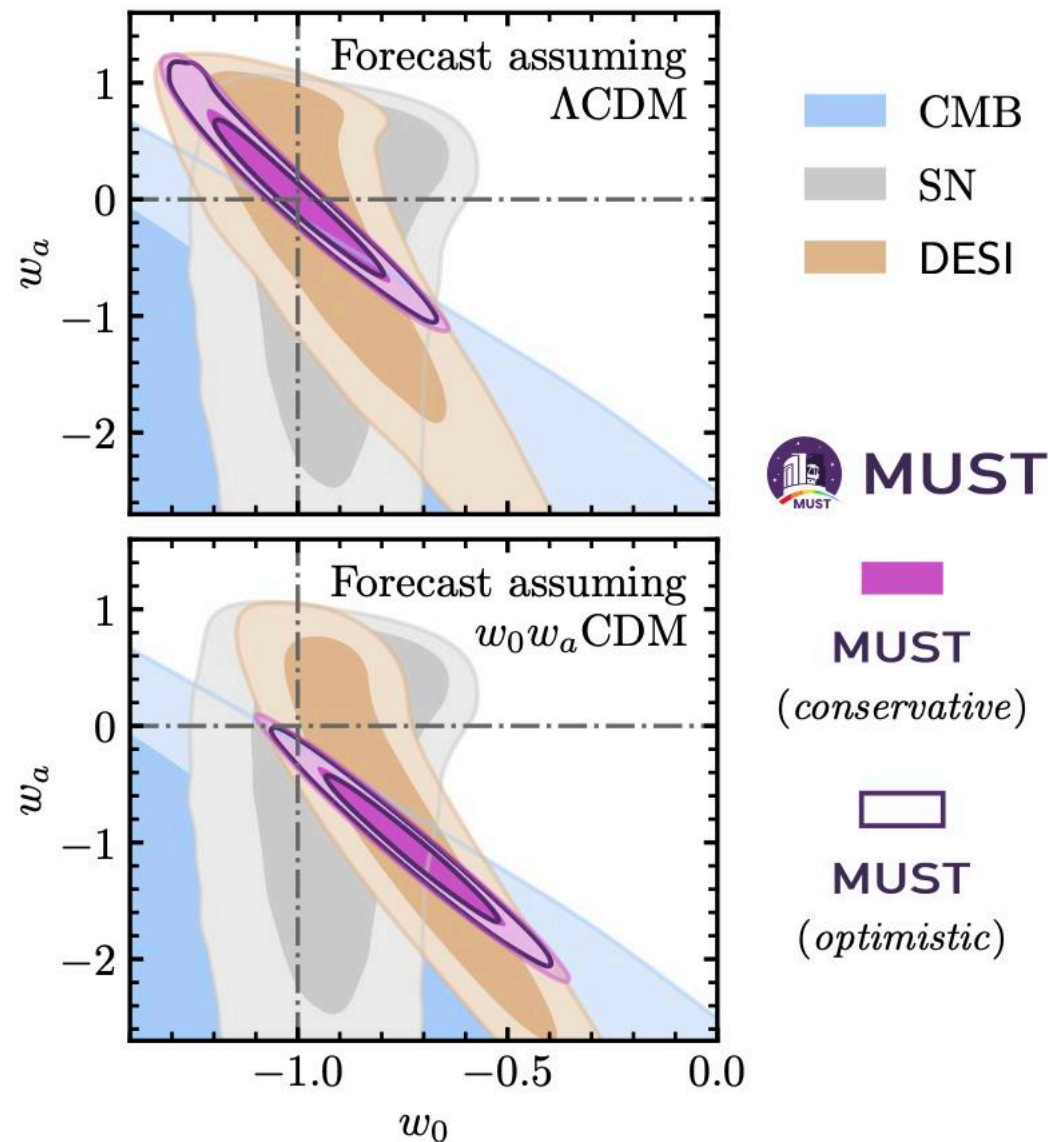
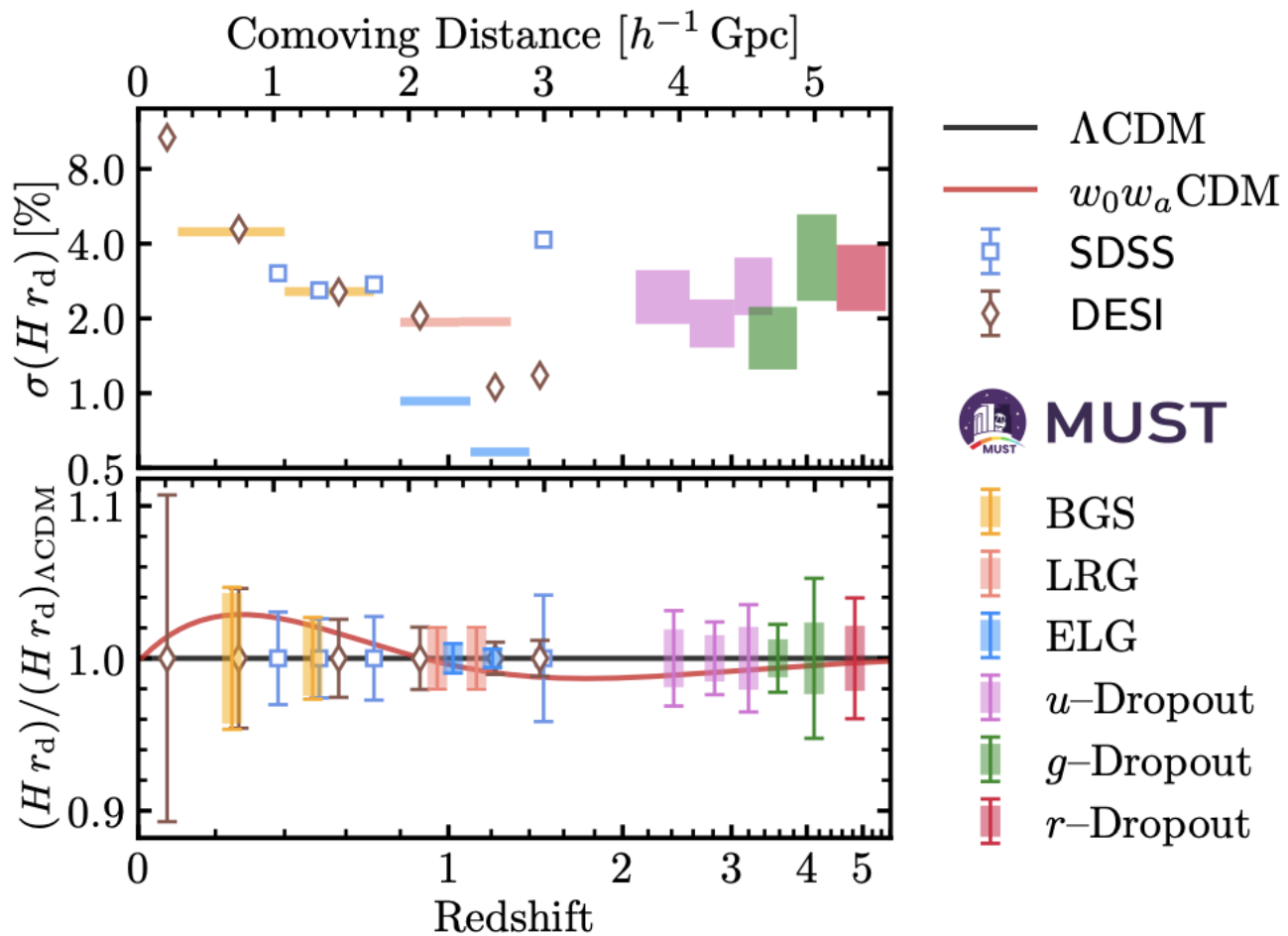



Scientific Roadmap & Requirements

Key Scientific Requirements (Examples):

MUST Focal Plane (FF) System Block Diagram NOT To Proportion

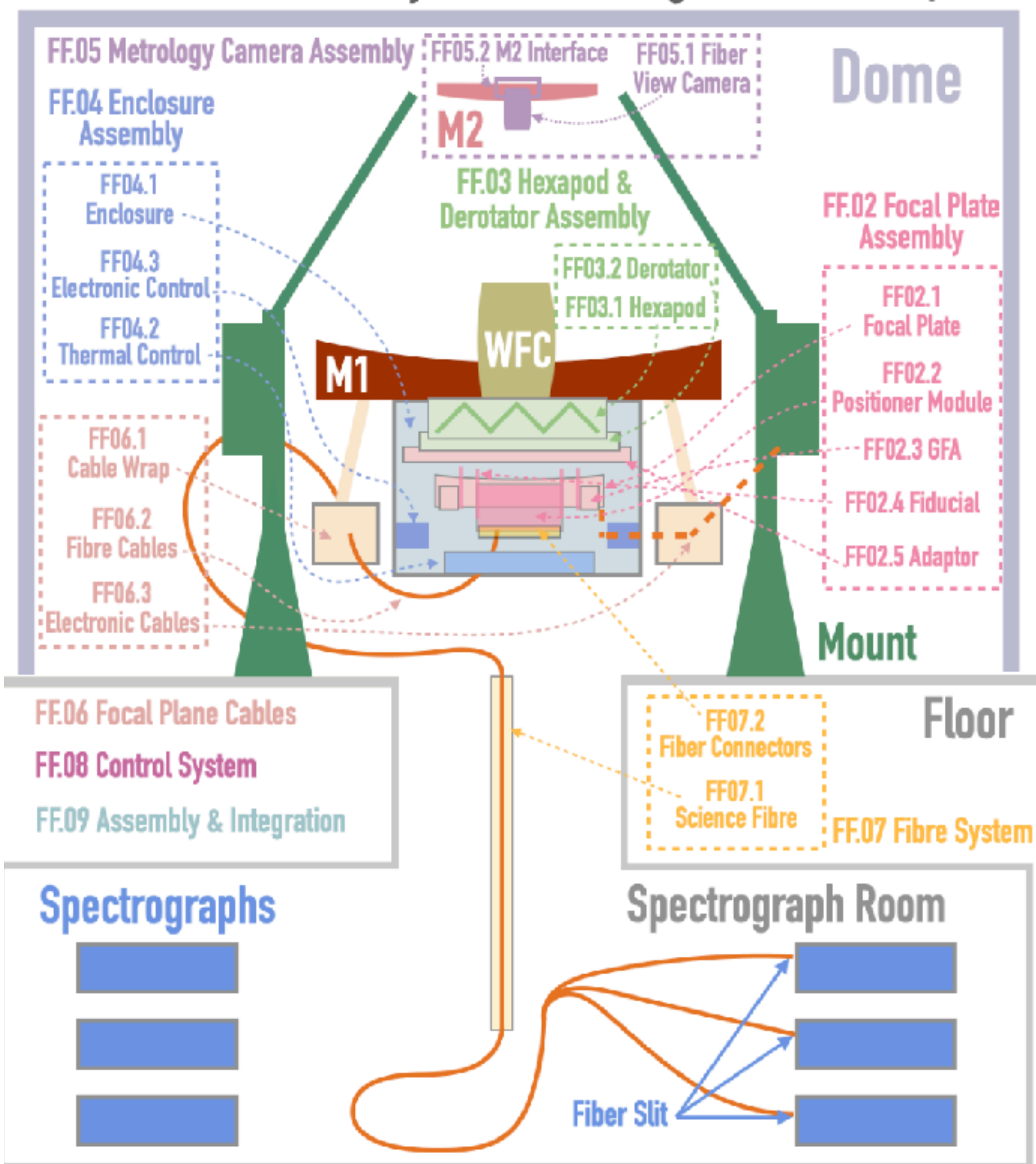

- MUST should achieve a **>90% redshift success rate** for a fiber magnitude (1.2 arcsec fiber) **$g < 24.6$ mag ELG at $z < 1.4$** in **1,200s** effective exposure time to result in at least **2,500 per square degree** target density within a **>11,000 deg²** effective survey area.
- For **$r < 24.5$ mag LBGs (u-dropout)** at **$z < 3.5$** , MUST should achieve a **>70% redshift success rate** in a **2.5-hour exposure time** and a target density of **>600 per square degree** within a **>8,000 deg²** effective survey footprint.

Everything is a Challenge!

- For example: Imaging Survey Data
- Will analyze & refine these requirements and use them to guide the system design.

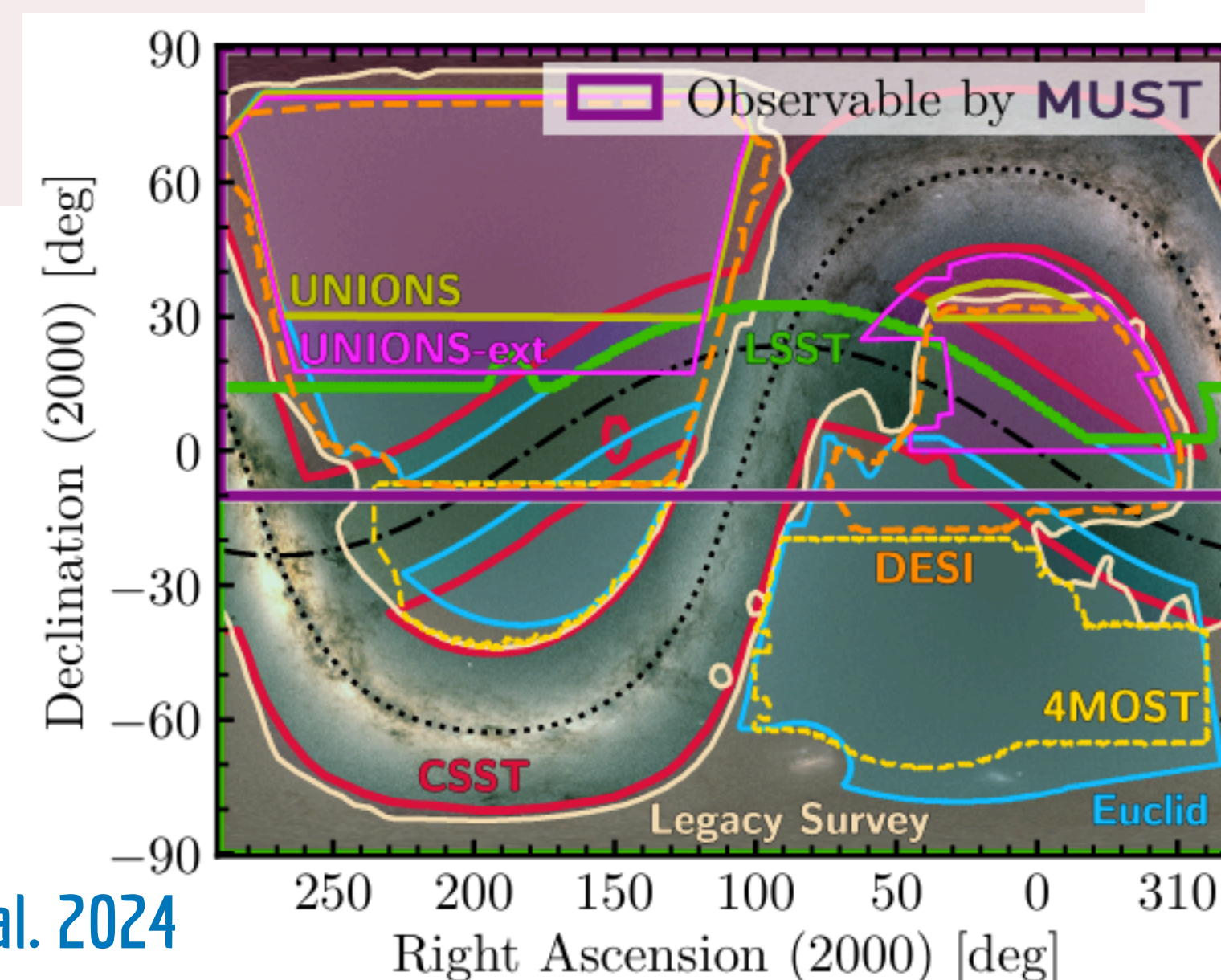

• Cheng ZHAO, et al. 2024

Manufacture & Assembly Facility in Jiangyin

MUST Focal Plane (FF) System Block Diagram NOT To Proportion

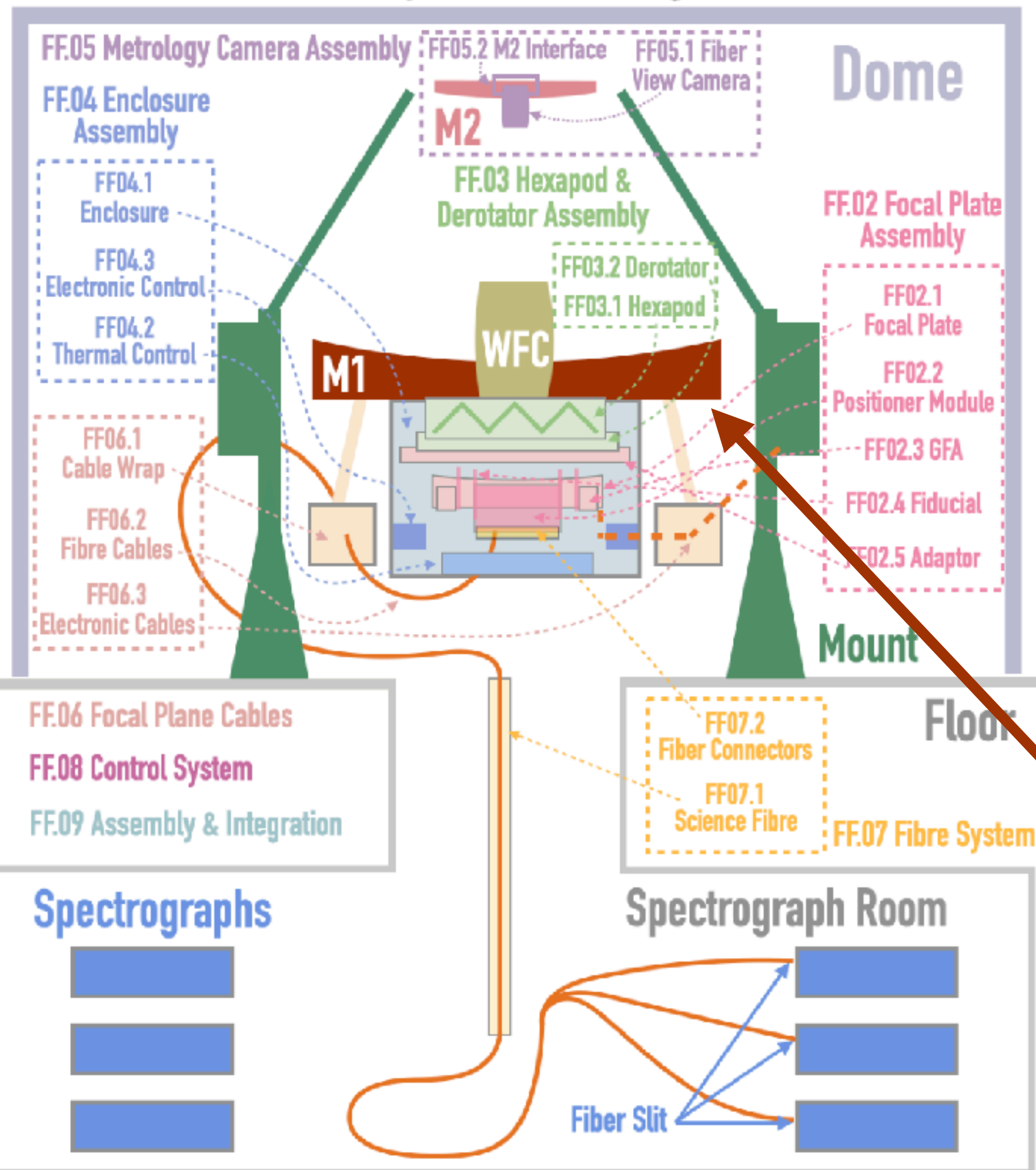

- Finished and already put to use.
- Will become a full optical-mechanical assembly center.



Primary Mirror

- **6.5m SiC primary mirror:** passed the preliminary design review and is being prepared for casting.
- Collaborating to design and test the reflective coating and the protection & cleaning procedures.

MUST Focal Plane (FF) System Block Diagram NOT To Proportion

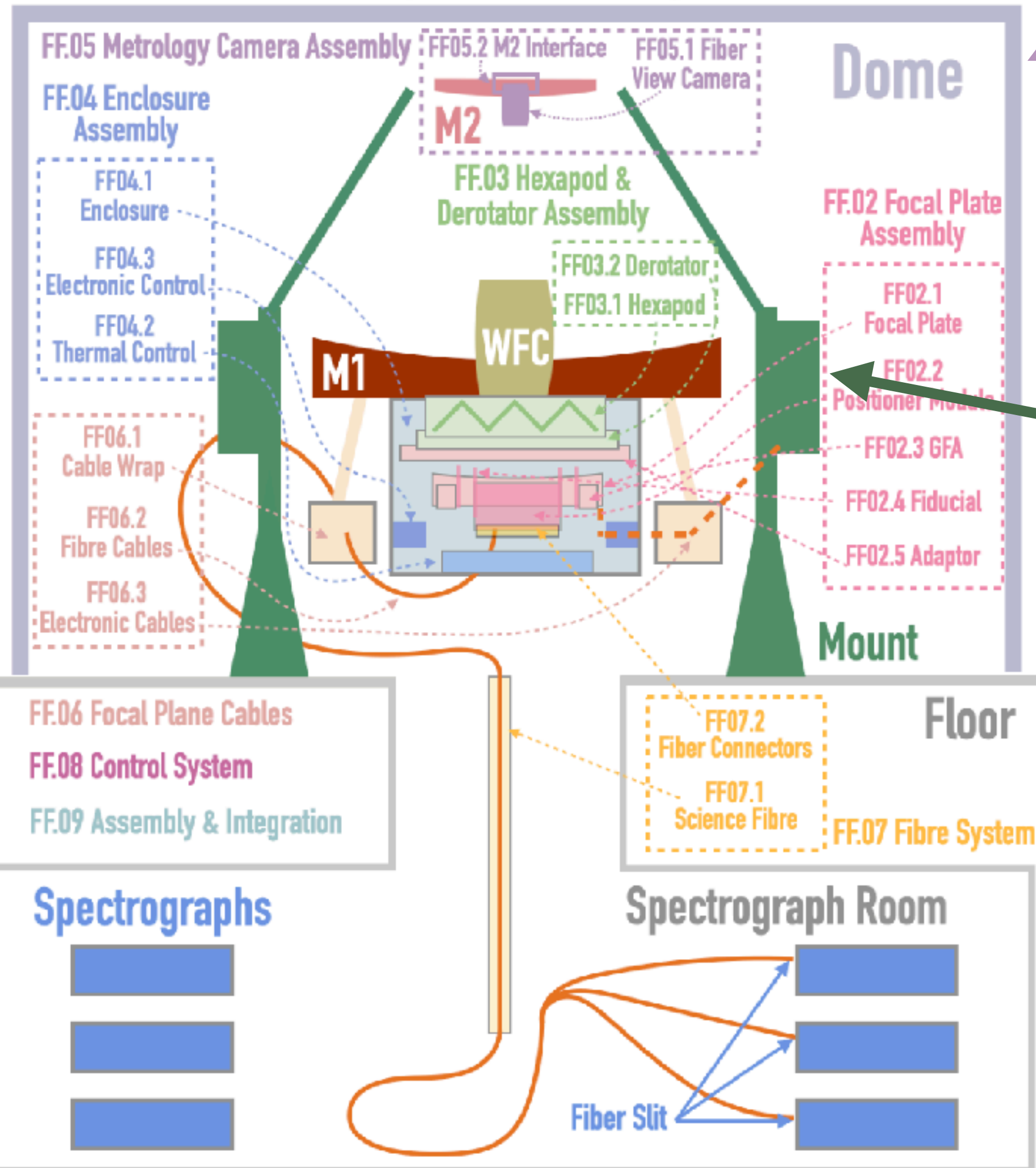

Dome

- Iterating the design with EIE, especially the requirements for the spectrograph rooms.
- Now, MUST's dome will be part of a **summit facility** with another telescope.

Mount & Structures

- Passed the **PDR**.
- Identified a few critical interface issues with the Focal Plane Systems (mostly the fiber route). Will focus on them in the following year.
- Low temperature on-site is a significant challenge.

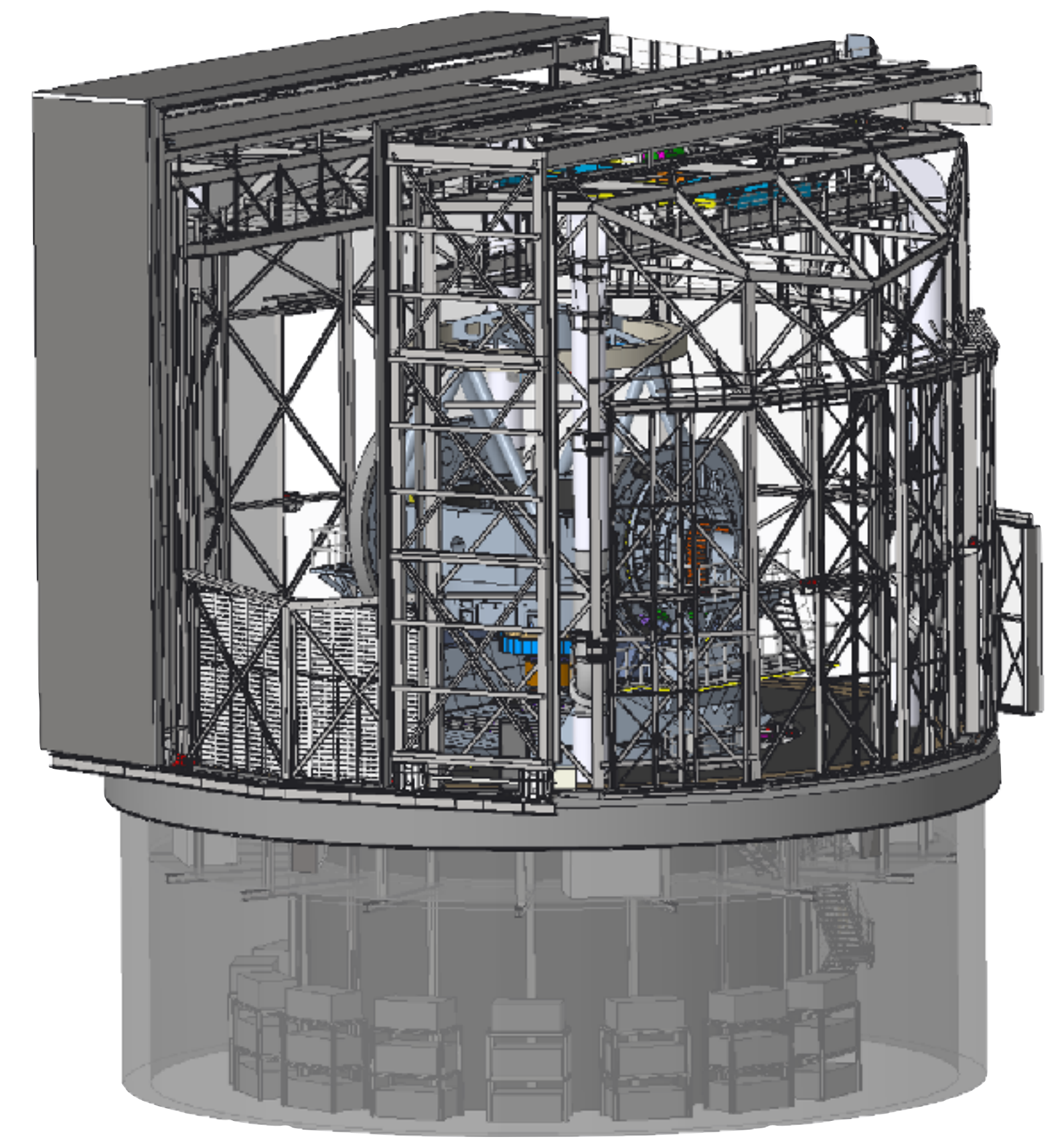

MUST Path Finder

- Finished & Installed on site. Is being commissioned as we speak.

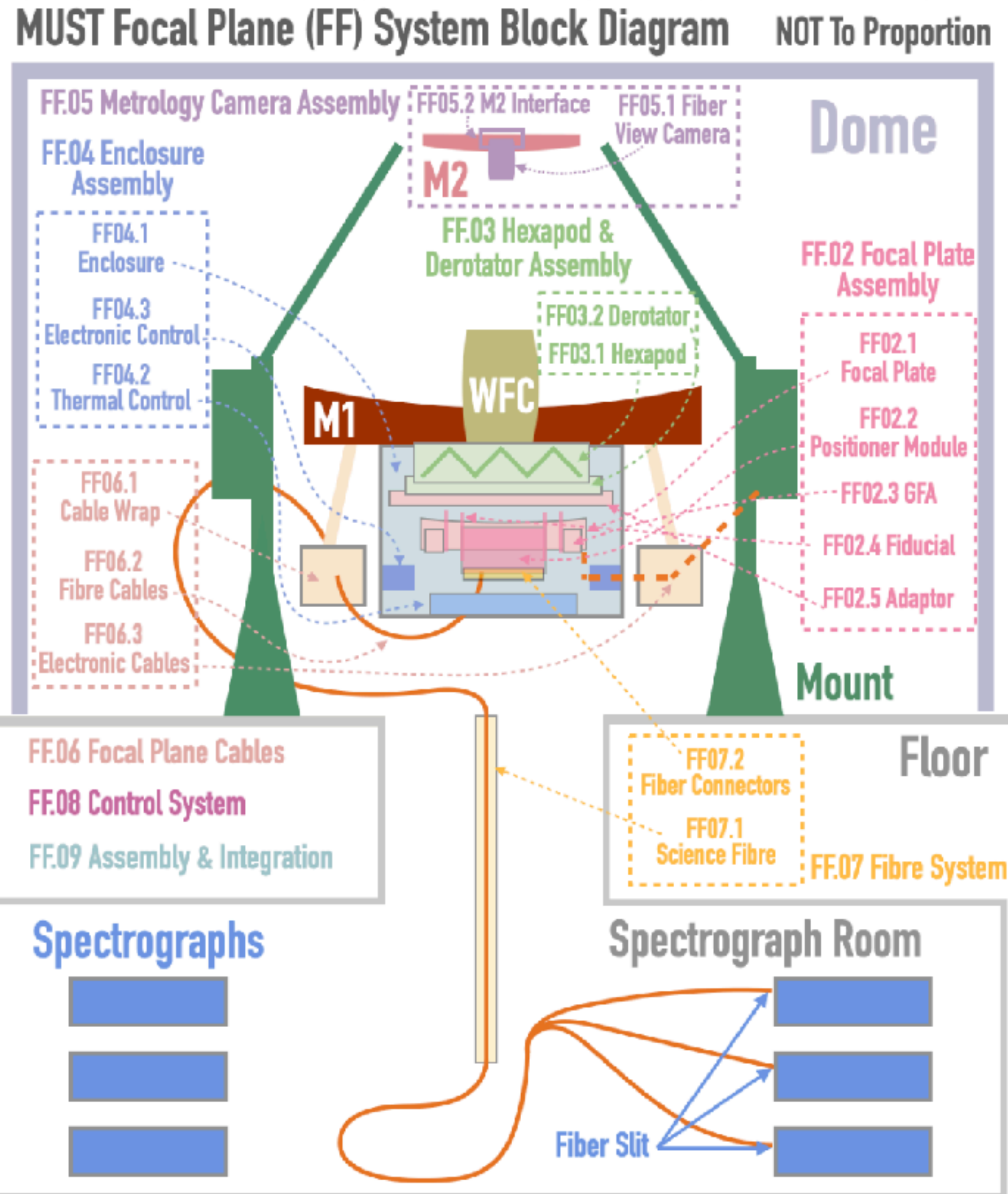

- Equipped with a CMOS camera, it will carry out simple observation for **Site Monitoring**, education, and science.
- More importantly, will help us develop the **TCS & OCS**, and help us rehearse the **Telescope Operation** on the summit.

Focal Plane System

FF.02.1 Focal Plate

- **Requirements** are near ready; confirmed that it could be manufactured in China; plan to carry out more prototyping tests.
- **Risk:** Many critical interfaces with the rest of the FPS.
 - Highest priority: with the FPM; related to the FPS assembly and maintenance

• **Testing different metrology and measurement approaches now.**

• Exploring the feasibility of installing it inside the FPS for in-situ metrology

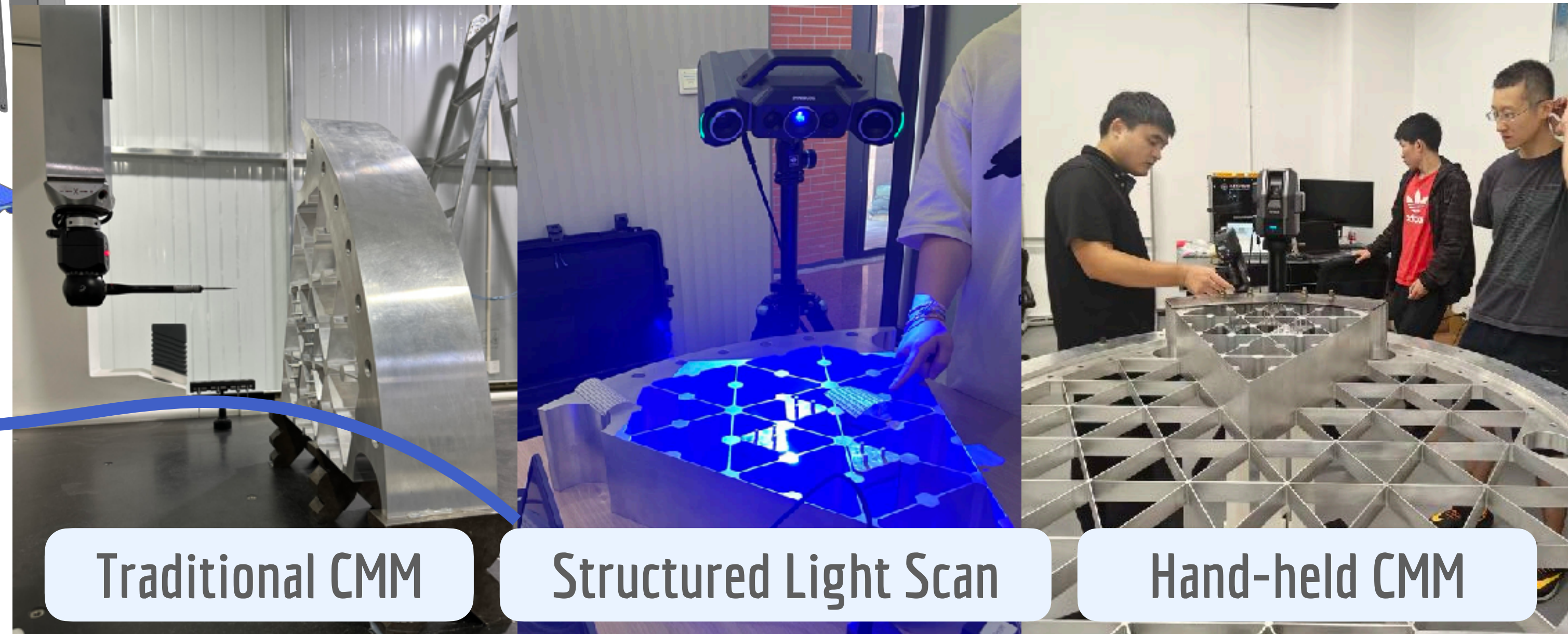

Traditional CMM

Structured Light Scan

Hand-held CMM

Throughput

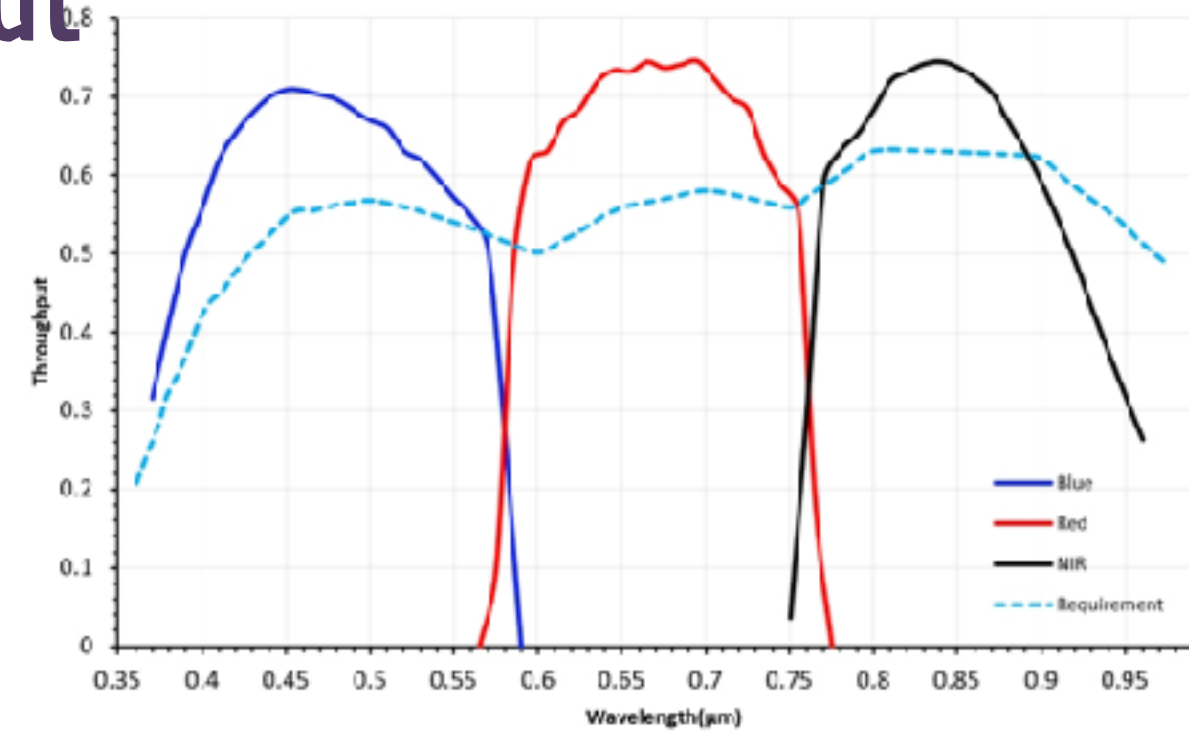
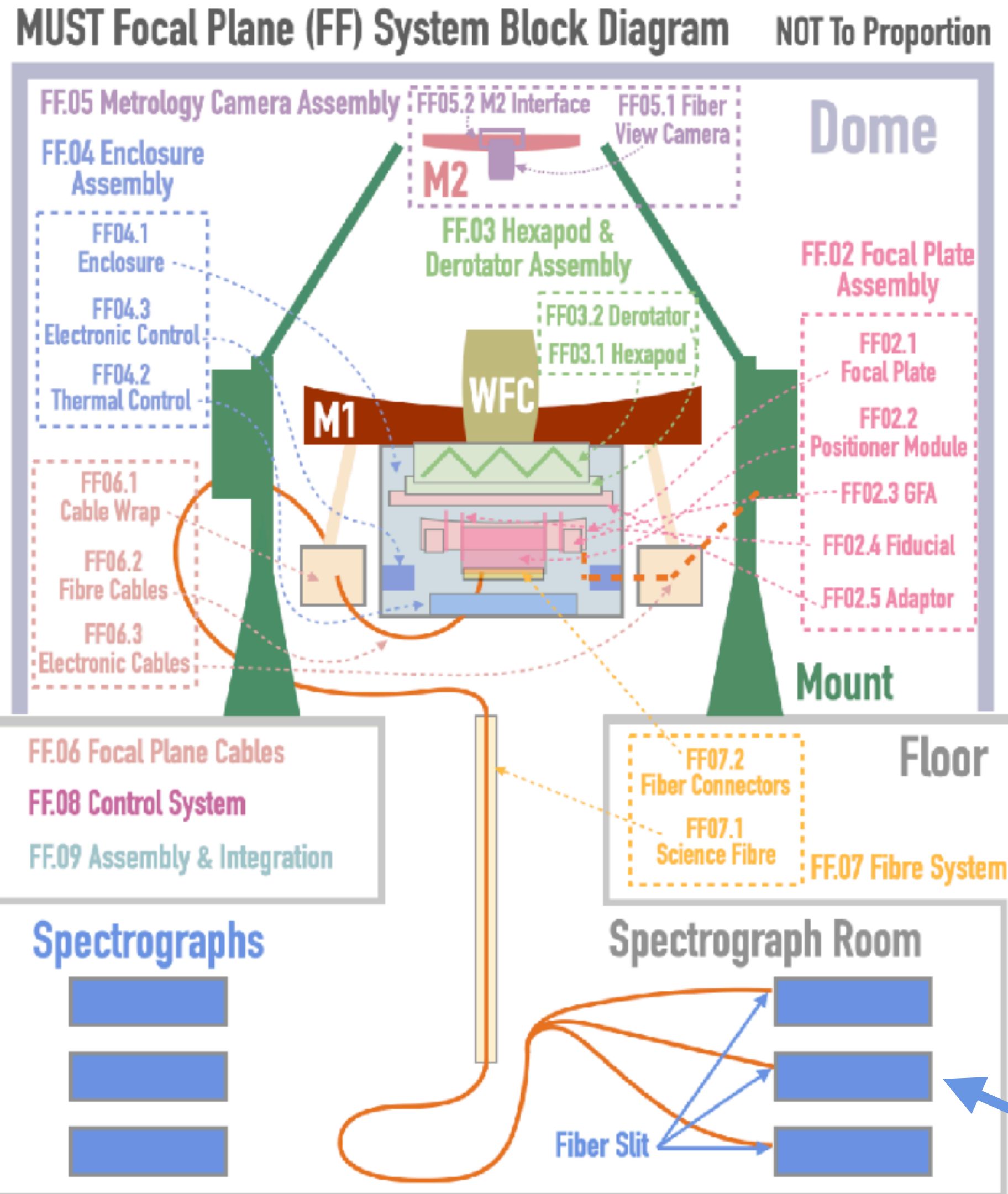

Figure 31 End-to-End throughput of the spectrograph system.

Spectral Resolution

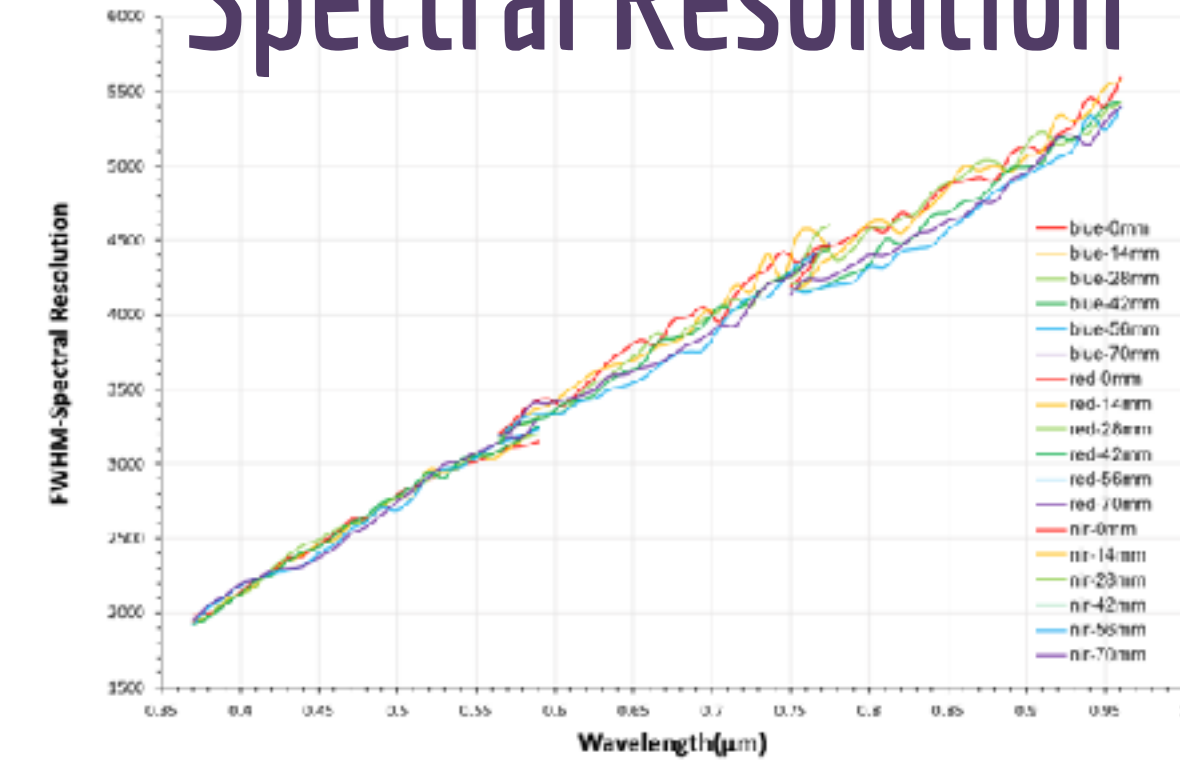
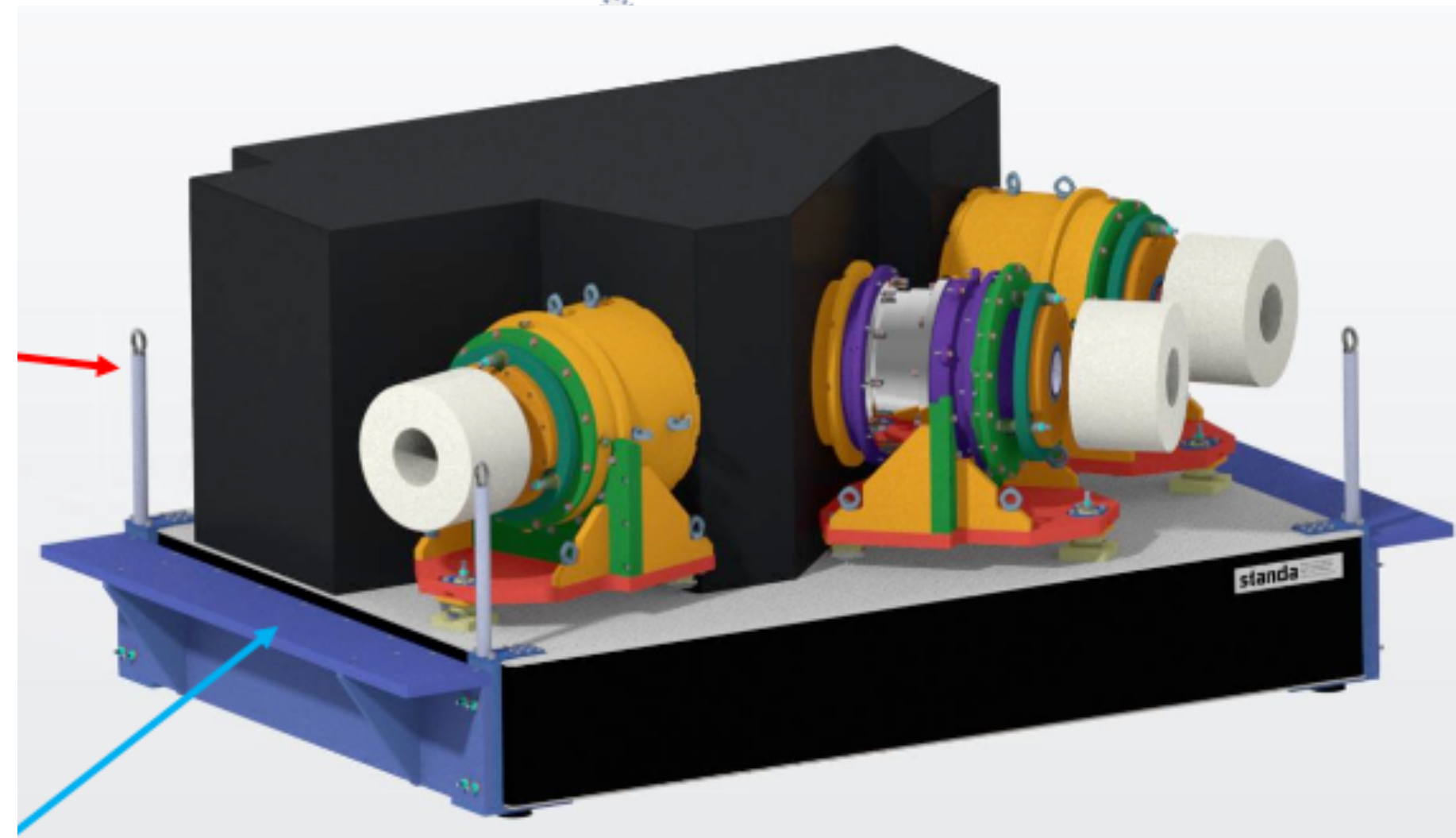

Figure 29 FWHM spectral resolution for the ideal system of different FOV.



- **Detectors**
 - Purchased for 12 spectrographs.
- **Cryostats**
 - Will be produced by CIOMP
 - Using a state-of-the-art cryocooler.
- **Need Help:**
 - **Fiber Slit; ATI; etc**

Spectrograph

- Come up with an independent design; Finished the Conceptual Optical-Design Review
- Identified collaborators for the optical spectrograph.

STA5800 100um Fully-Depleted CCD 1:1 Scale Projection of the Spectrograph

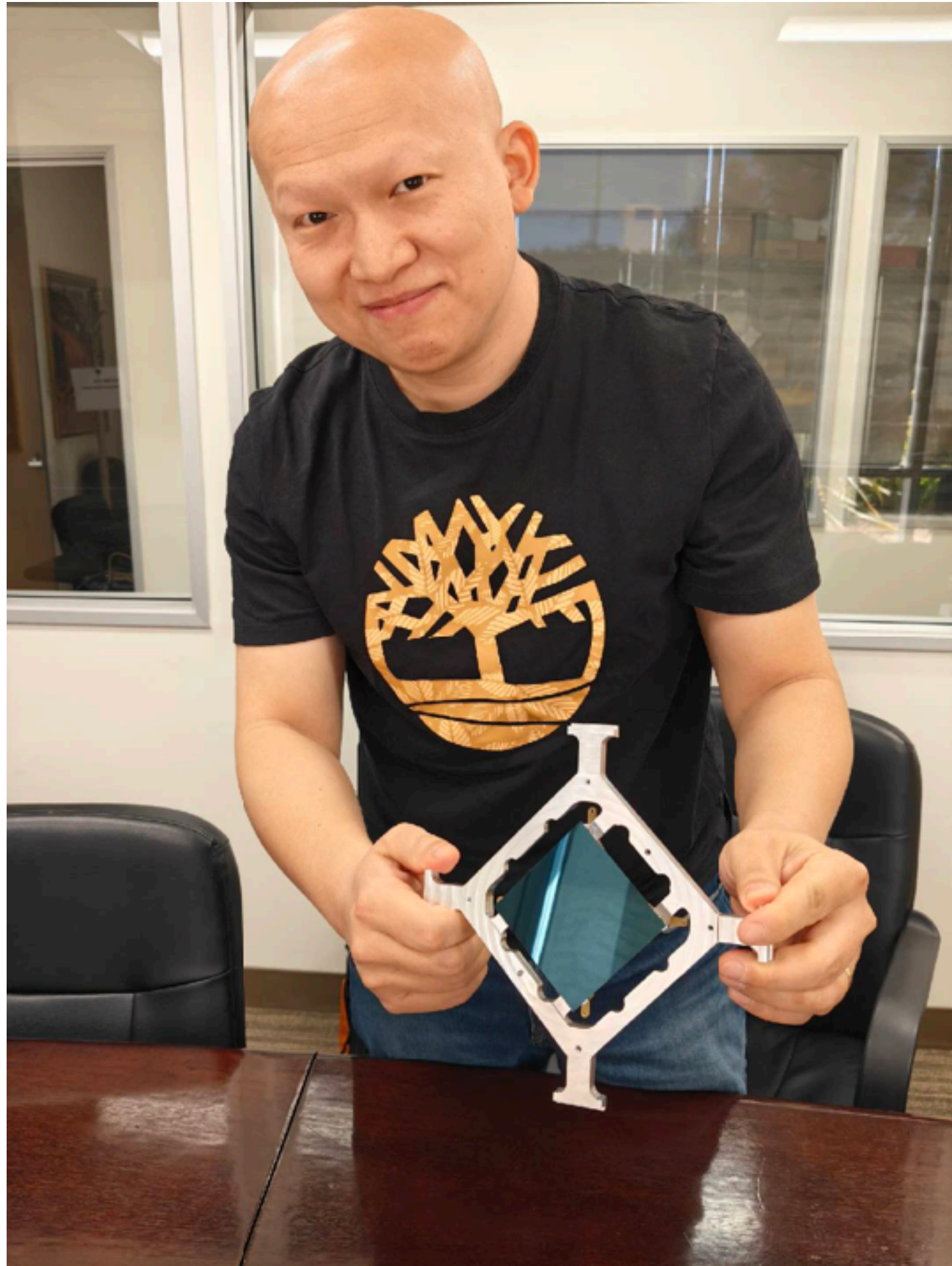

4k x 4k 15um Back-Illumination **Gpixel**

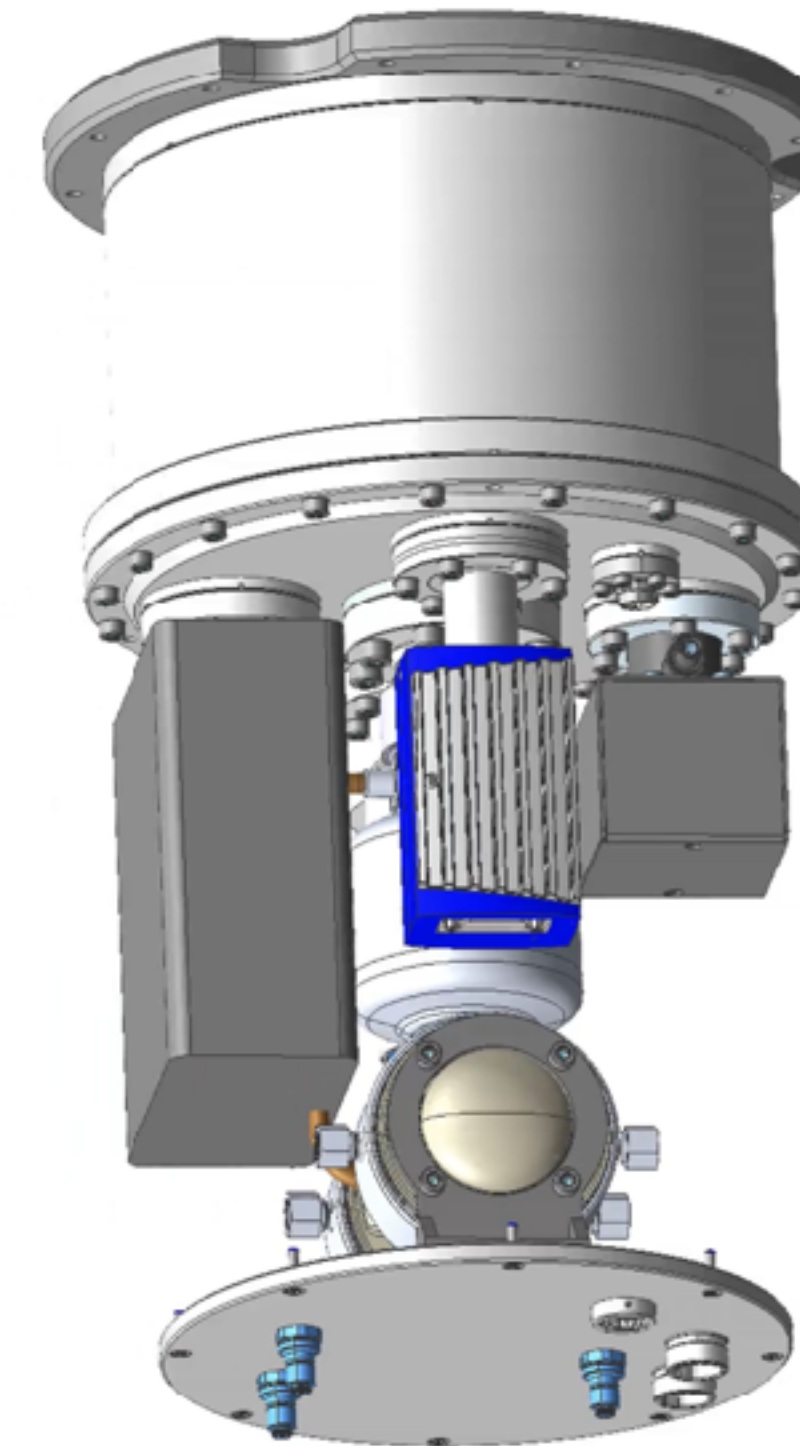

sCMOS by Gpixel

Cryostat + FEE design
by CIOMP using LiHan
LPT Cooler



Overall Schedule

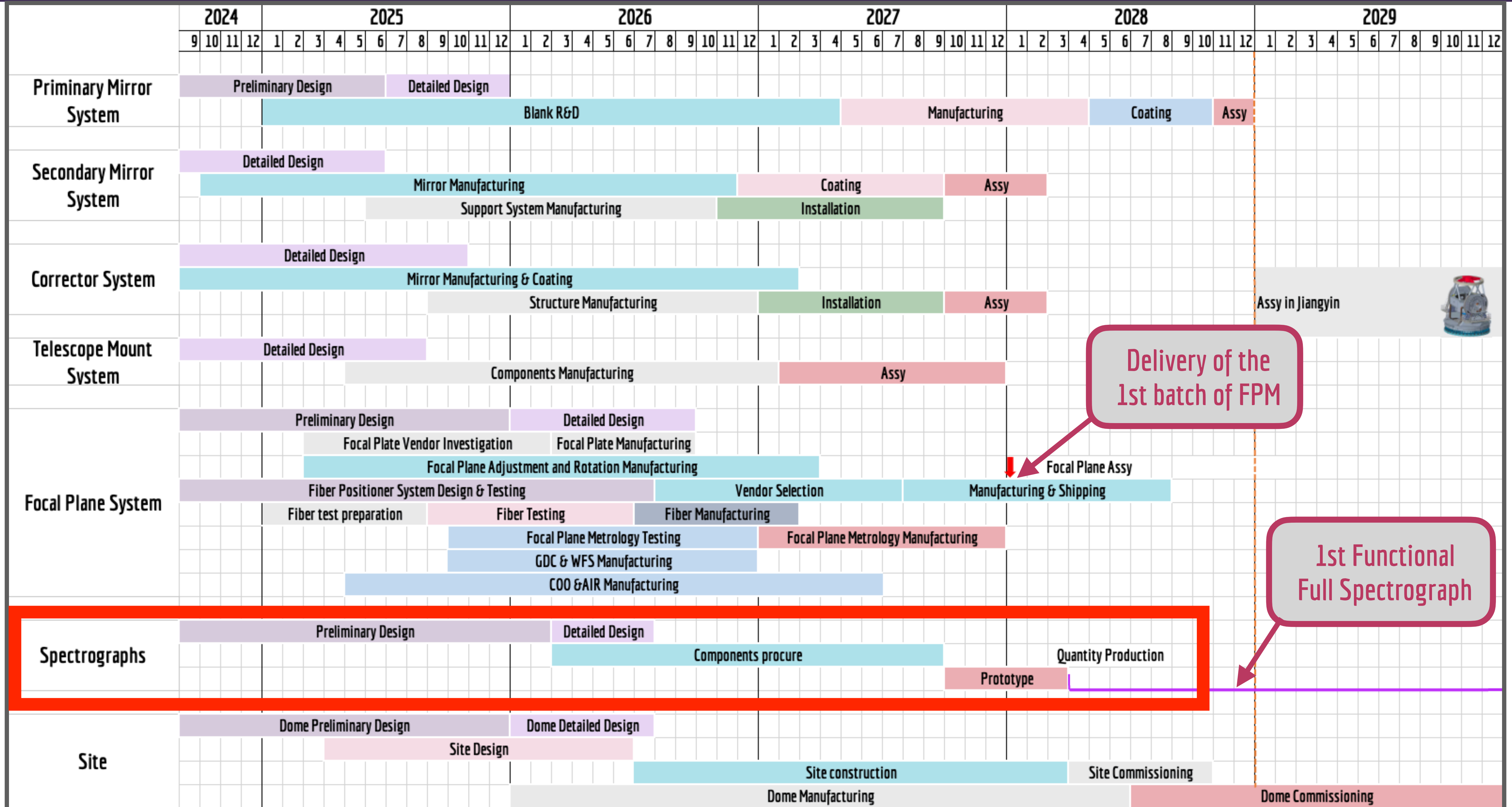

Delivery of the 1st batch of FPM

1st Functional Full Spectrograph

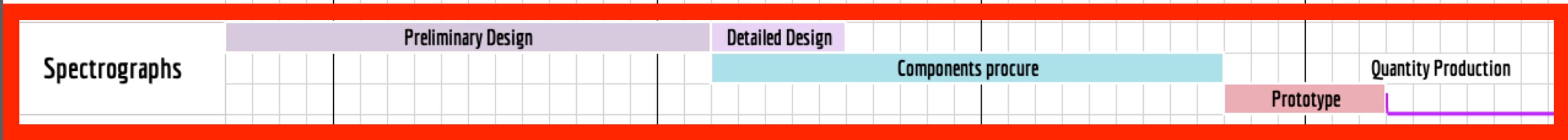

Digital Twin Workstation

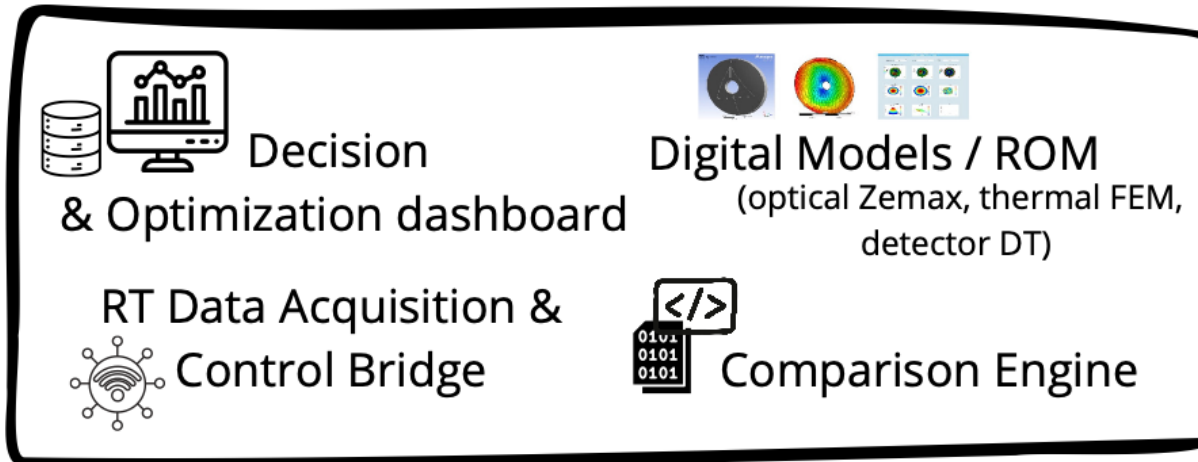

Acquisition & Control (IoT, USB, ...)

Spectrograph & Test Tooling

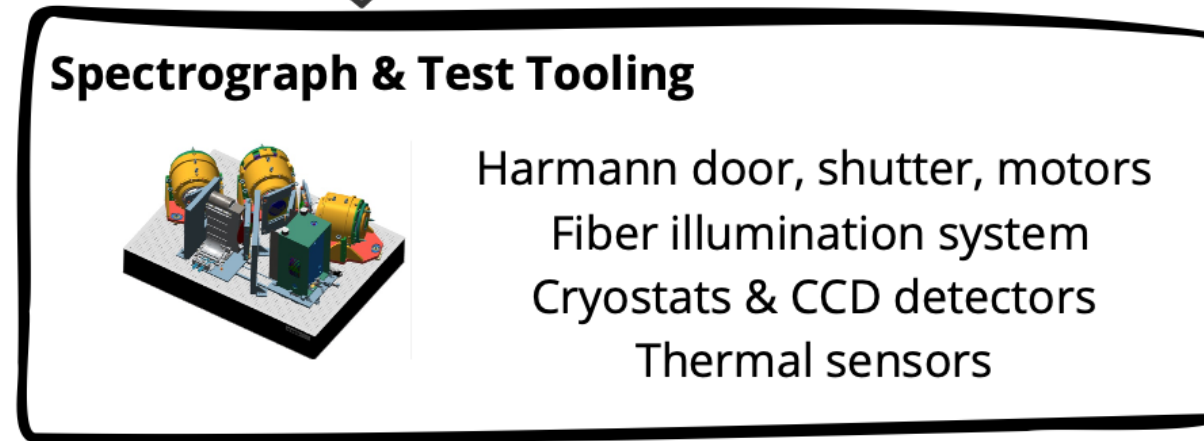

=>Alignment & Validation solution for spectrograph series
(eg. 40 spectro for MUST / 140 for WST)





Overall Schedule

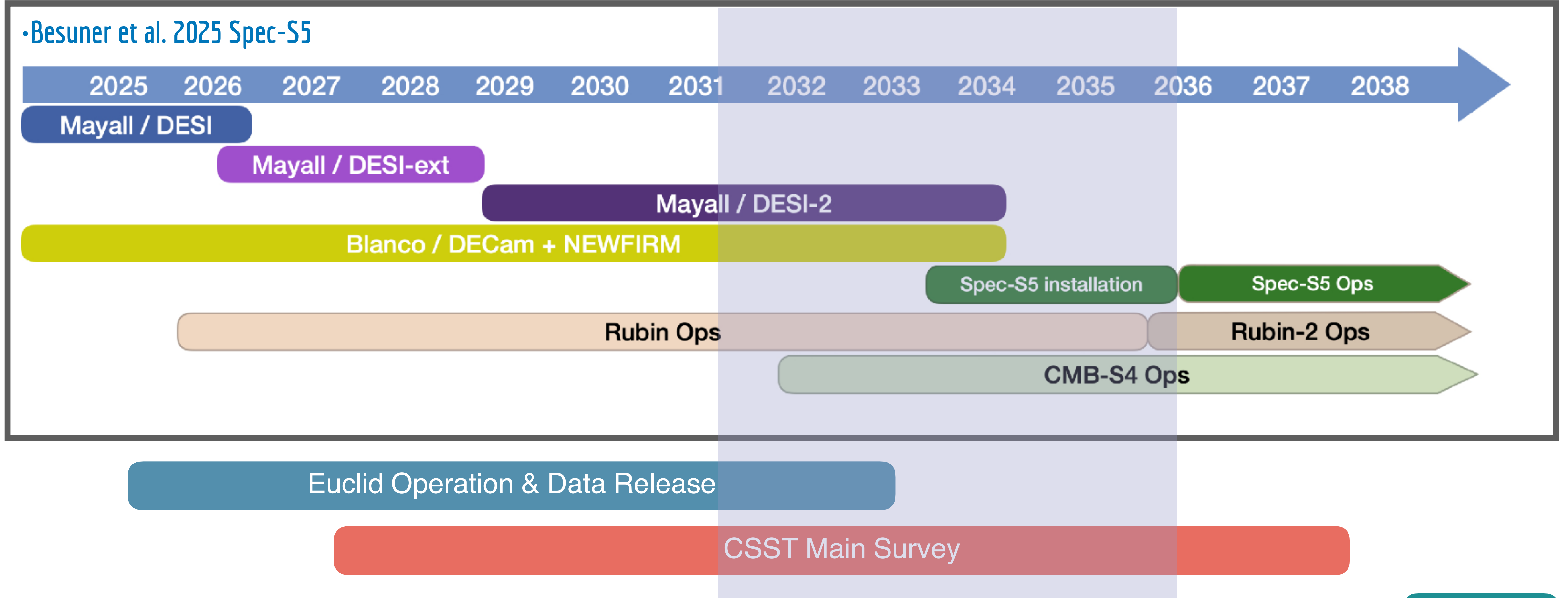

•While we do not aim for a “**competition**”, there is one: **Spec-S5**, while being uncertain, is still leading us in **technical development** of the next-gen instrumentations and in the **experience** of running a large spectroscopic survey (by A LOT!).

•The **5-6 year window** is crucial for us!



MUST is a suitable **WST pathfinder!**



Still Growing Scientific Collaboration

At Tsinghua



Cheng Zhao



Song Huang



Zheng Cai

At EPFL



Jean Paul
Kneib

CPPM



Willam
Gillard

LAM



Eric Jullo

LPNHE

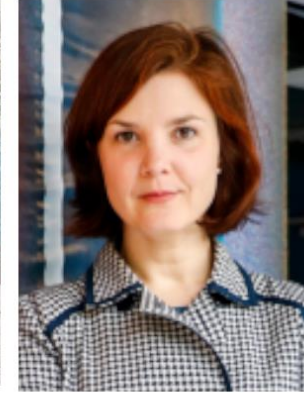

Pauline
Zarrouk

CEA



Etienne
Burtin

- Will have a **Wiki/Document/Membership/Slack-ish system** for the Science Collaboration
- MUST is **NOT just a cosmological survey**: Establishing **Scientific Working Groups** (You can contribute!).
- Having a **Bi-Weekly Science Telecon** (Wed morning in Europe). Everyone is welcomed to join!
- In France, we had a **French Meeting** in Marseille in April 2026 and a mailing list **must_france@lam.fr**



You?



Spectroscopic Surveys Over the World

Collaboration Policy

<https://docs.google.com/document/d/1c3MvChA3uh-42h4pSVkSKZfQ762LrBgG/edit#heading=h.hxrfwo5kbody7>

MUST Science Collaboration Policy (Construction Phase)

Version: Draft for Internal Discussion

1. Preamble and Scope

1.1 Purpose

The **MULTiplexed Survey Telescope (MUST)** is a 6.5-meter-wide-field telescope designed to conduct next-generation cosmological spectroscopic surveys. MUST is led by Tsinghua University, which hosts the Project Office, and is being developed as an international collaboration that includes domestic and international partners.

The purpose of this **Science Collaboration Policy ("the Policy")** is to define the organisational, membership, and publication framework for the Construction Phase of MUST. The Policy aims to provide a clear, transparent, and fair basis for participation in the MUST Science Collaboration and for recognising monetary, in-kind, and scientific contributions made during this period.

- Follow the example of DESI, but want to be more **flexible** at this stage.
- In principle, **Open** to Everyone, without guaranteed data right.
- We welcome (direct/in-direct) **funding and in-kind contributions**, and looking forward to working toward signing MOU or research agreements with Institute or Research Groups with agreed-upon contributions.
- Individual can also gain **Data Right** through concrete contributions to the engineering aspects of MUST or the **"Critical Path"** for MUST's Science Preparation.



Science Working Group Chairs

- Galaxy & quasar clustering
 - **Ruiyang Zhao** (Tsinghua)
 - Siyi Zhao (Tsinghua)
- Lyman-alpha clustering
 - **Paulo Montero-Camacho** (Pengcheng Lab)
 - Francesco Sinigaglia (SISSA)
- Simulations
 - **Zhongxu Zhai** (SJTU)
 - Yu Liu (EPFL)
 - Daniel Forero-Sanchez (ICCUB)



Science Working Group Chairs

- Extragalactic Survey
 - **Meng Gu** (Tsinghua)
 - Tao Wang (Nanjing Univ.)
- Milky-Way Survey
 - **Wenting Wang** (SJTU)
- Time-Domain Cosmology (+ Peculiar Velocity Survey?)
 - **Fei Qin** (CPPM)
- Science Synergy
 - **Eric Jullo** (AMU)
 - Ji Yao (SHAO)



Science Working Group Chairs

- Target Selection
 - **Aurélien Verdier** (EPFL)
 - Xiaorui Yang (Tsinghua)
- Survey Strategy
 - **Mengfan He** (Tsinghua)
- Spectrum Pipeline
 - **Jiaxi Yu** (IPMU)
- AI for MUST
 - **Yin Li** (Pengcheng Lab)
 - Qiufan Lin (Pengcheng Lab)



Acknowledgement

Thank You!

