

Future missions for CMB spectral distortion measurements

X.COULON

on behalf of the **BISOU & FOSSIL** collaboration

2th of June, 2026

The standard cosmological model

Λ -CDM model

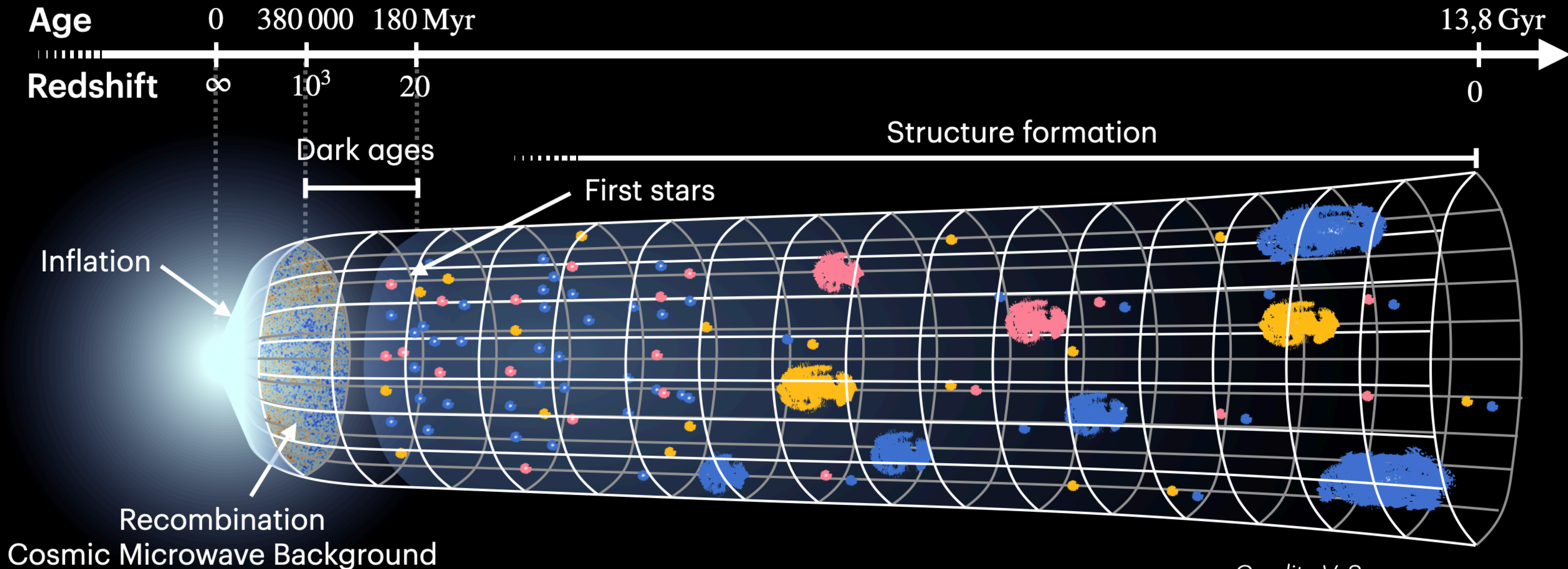

The CMB spectrum

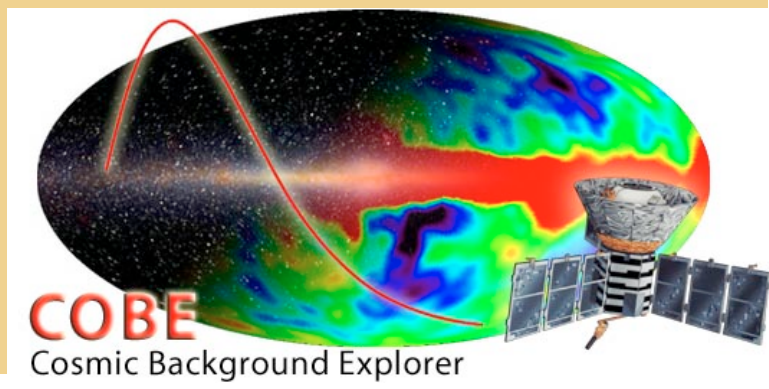

- **COBE** (COsmic Background Explorer)
 - **FIRAS** (Far-InfraRed Absolute Spectrophotometer):
 - $T_0 = 2.725 \pm 0.006 \text{ K}$ (95 % CL) *Fixsen+2009*

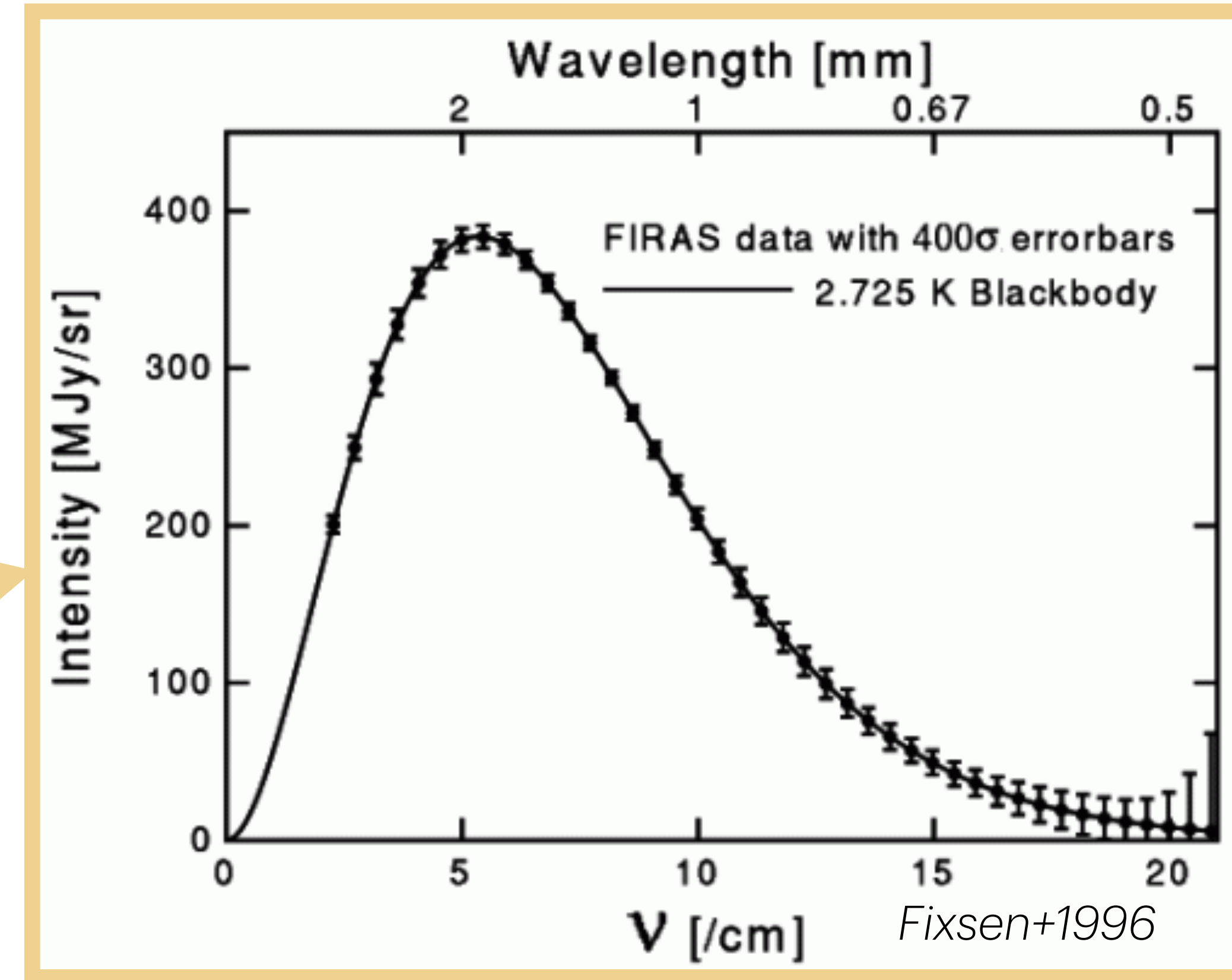
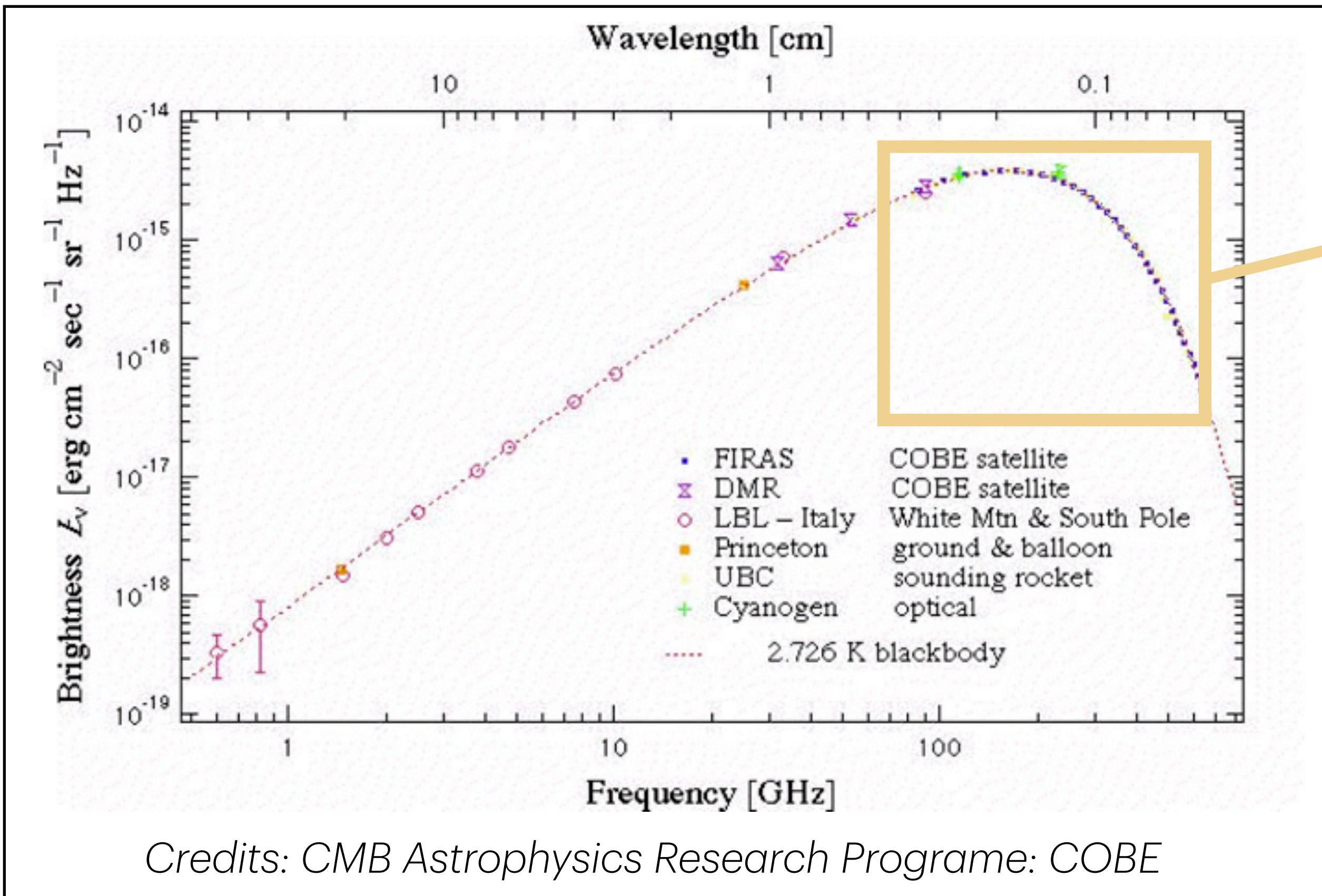

The CMB is the most perfect natural blackbody ever observed!

Thermalisation

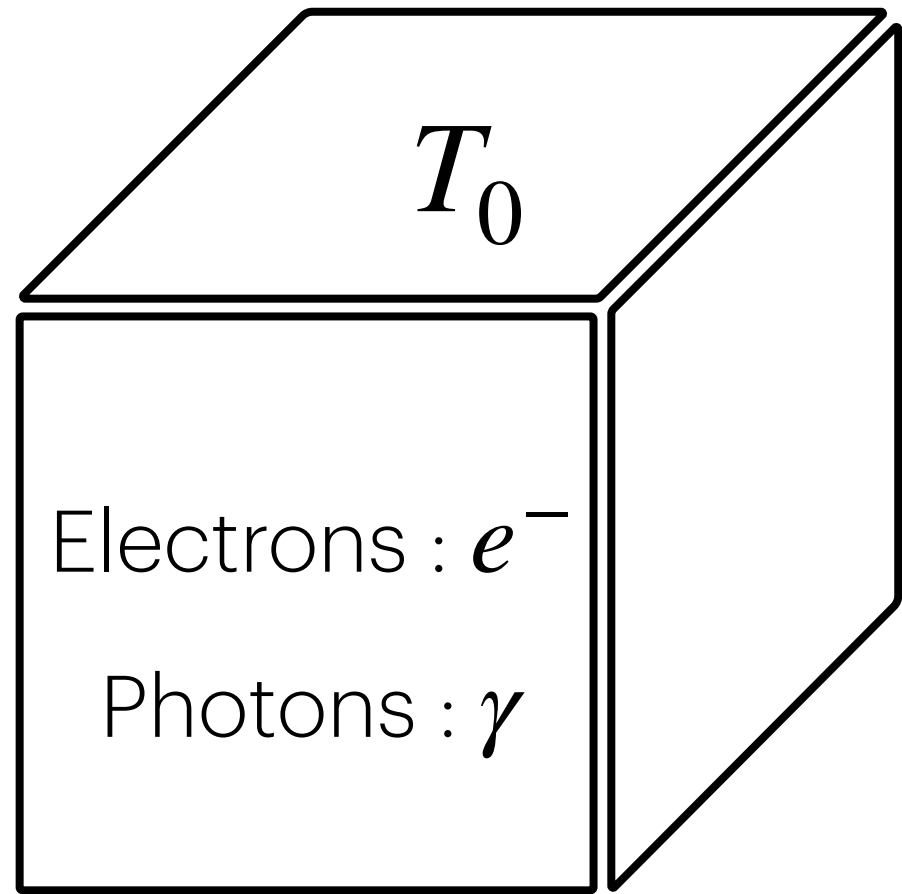

Blackbody at T_0

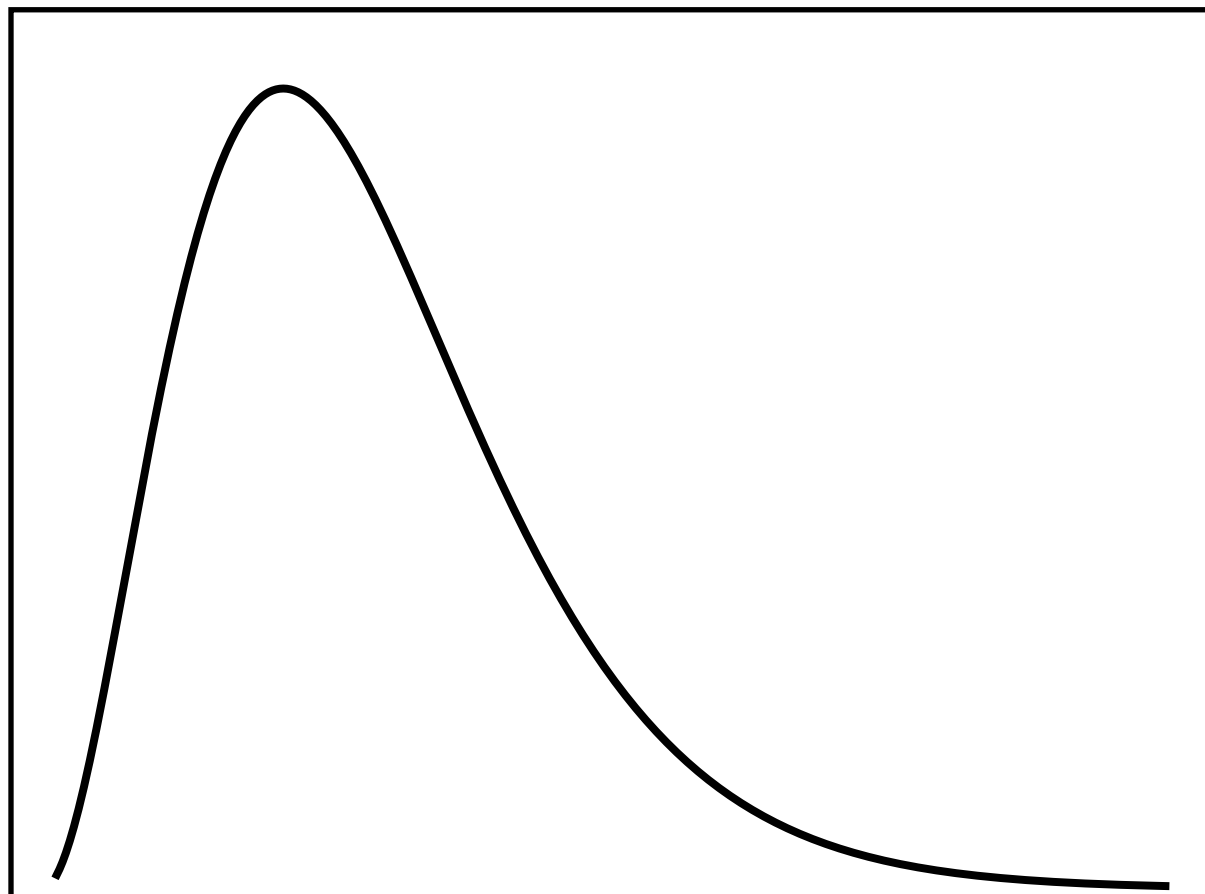

Thermalisation

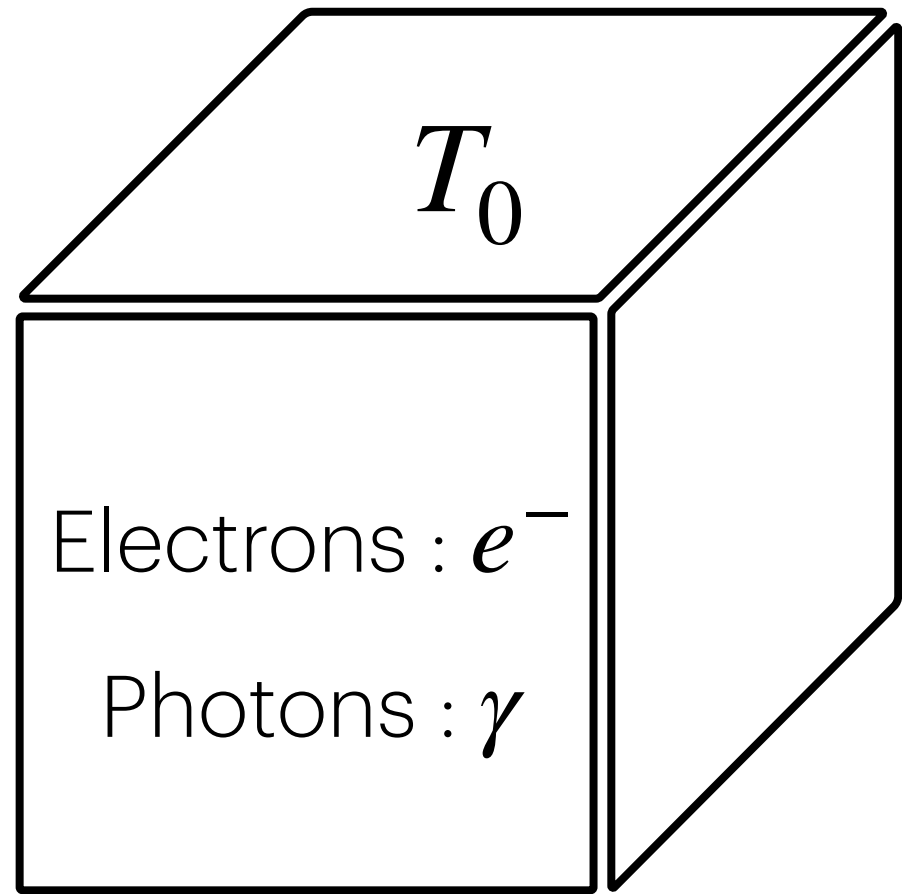

Heating of a wall of
the cavity
(energy injection)

Blackbody at T_0

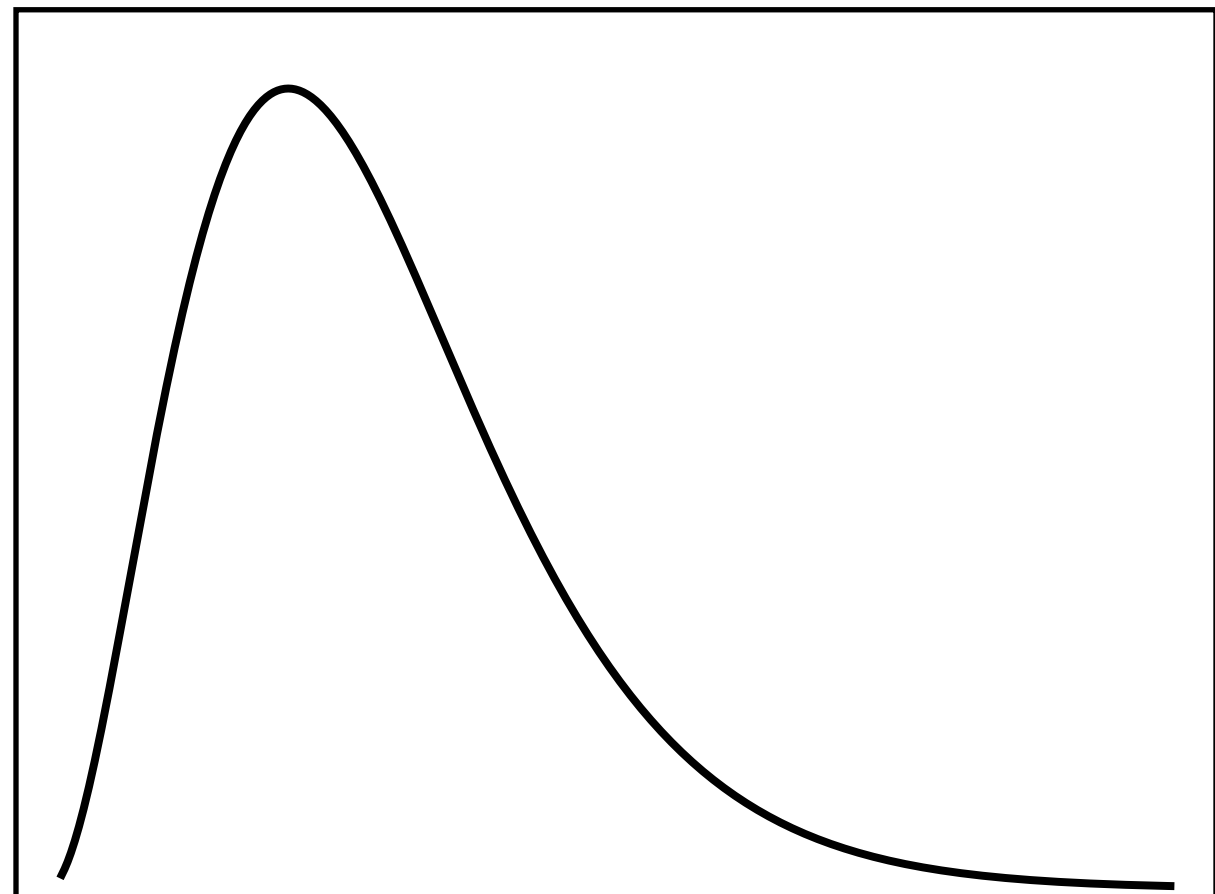

Thermalisation

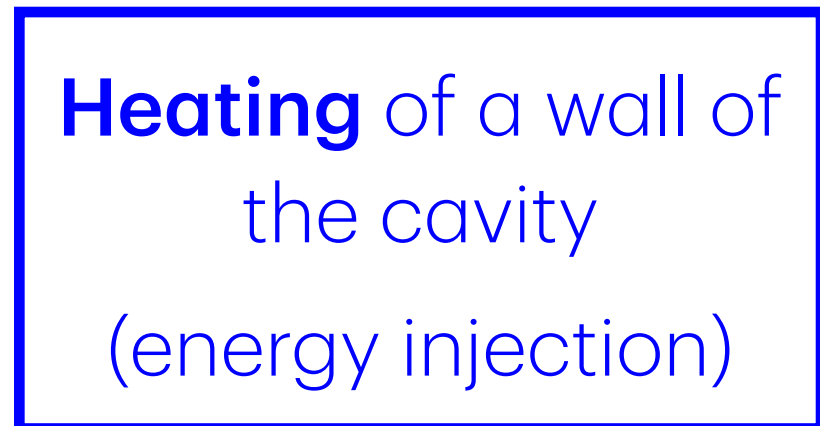
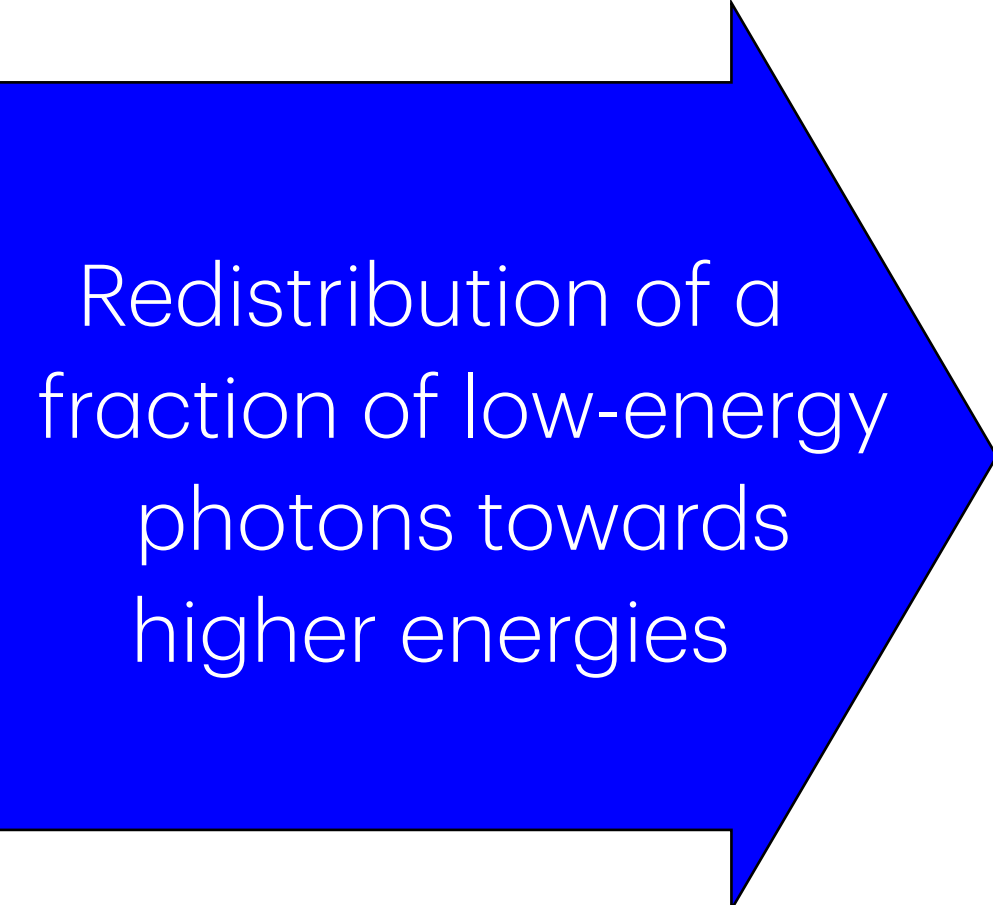
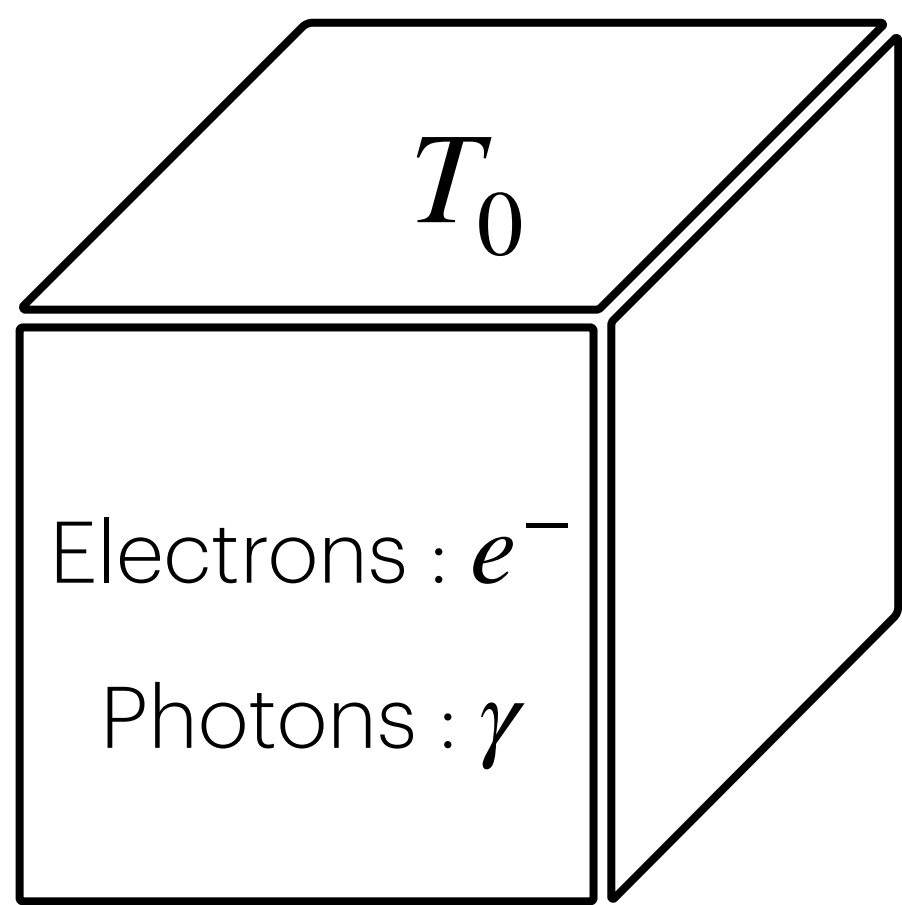

Blackbody at T_0

Distorted blackbody

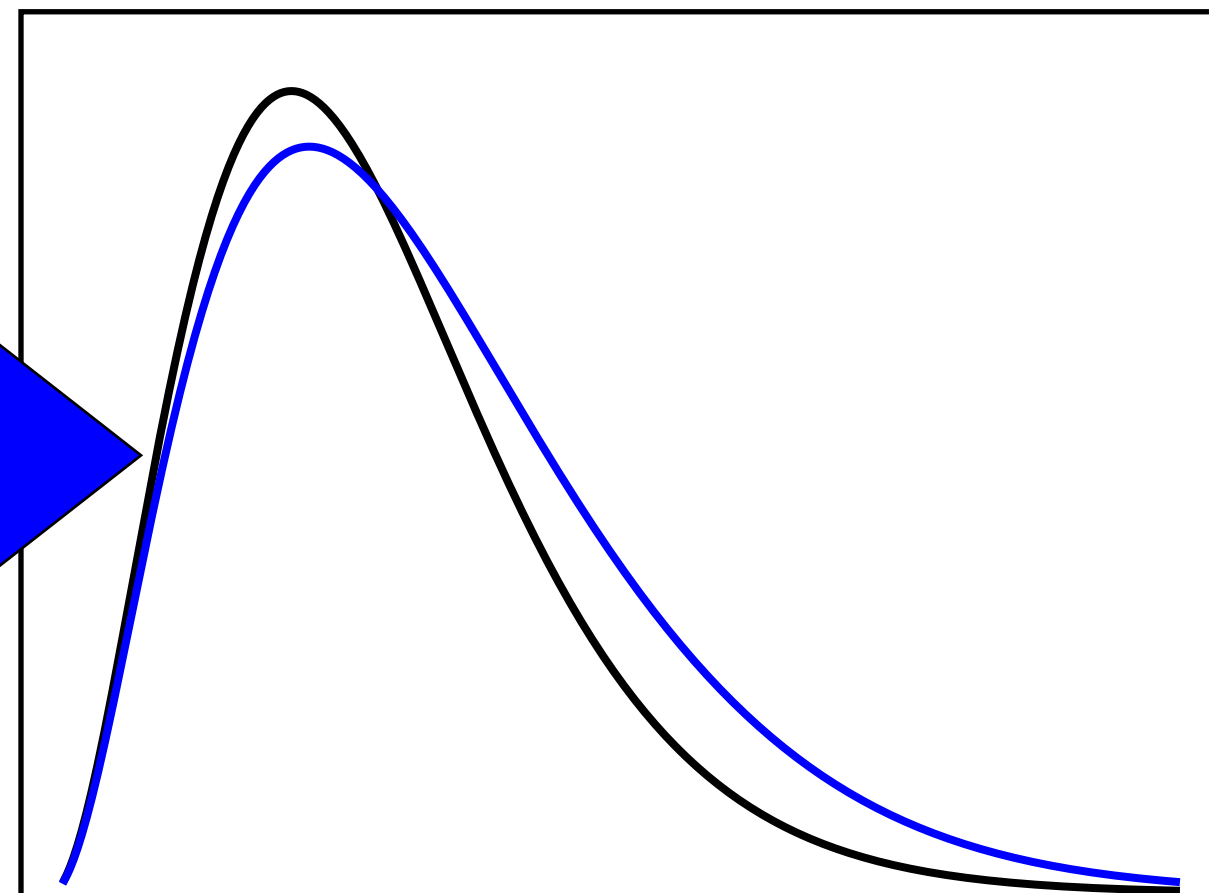
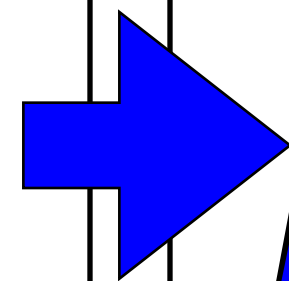
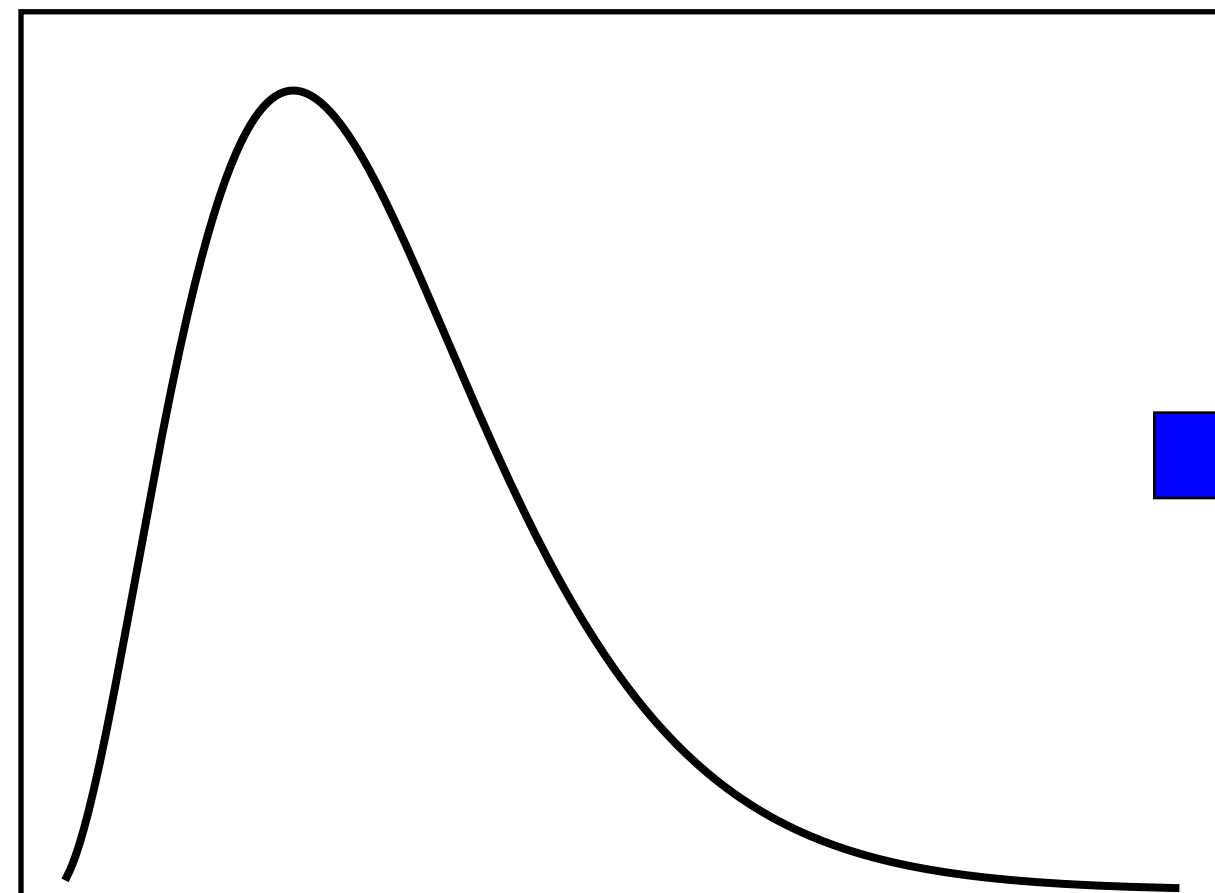

Thermalisation

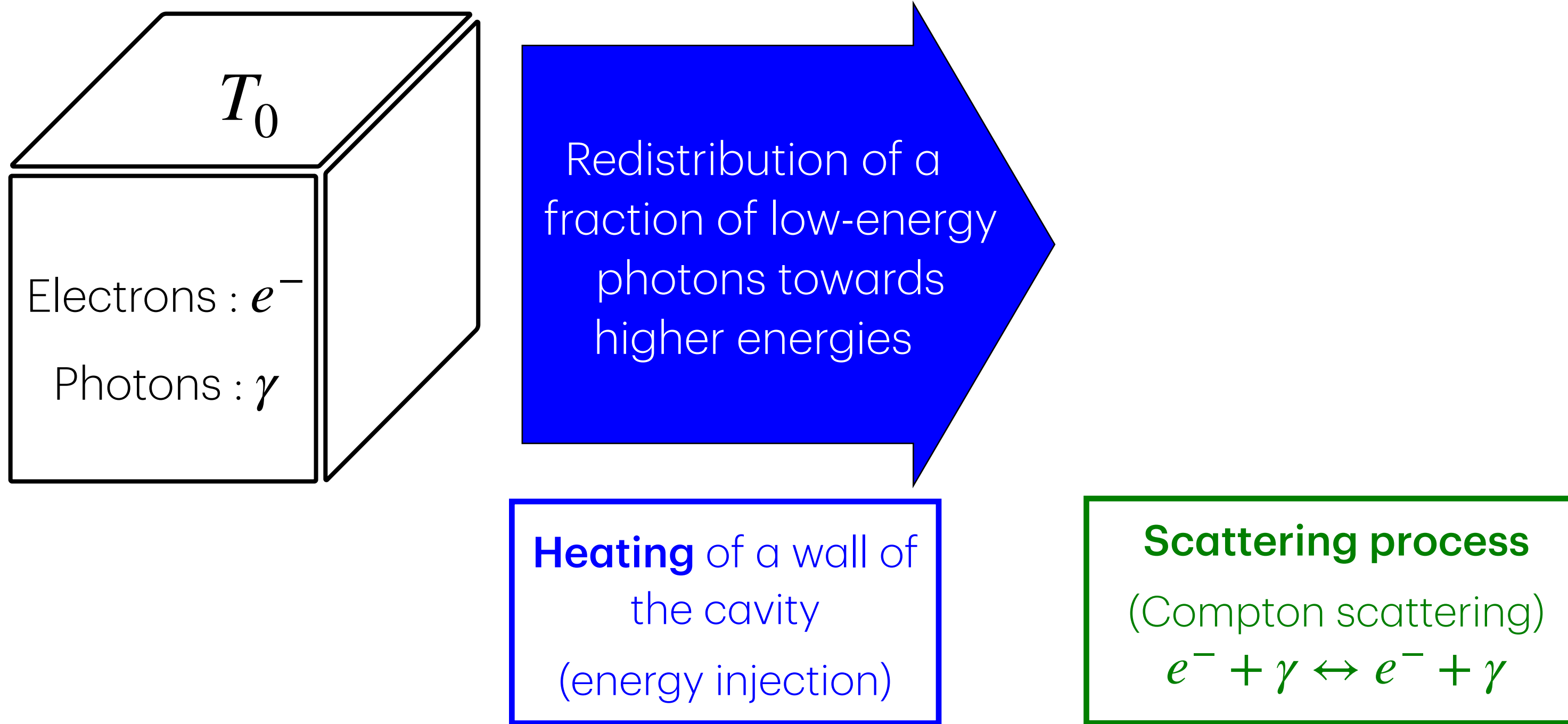

Blackbody at T_0

Distorted blackbody

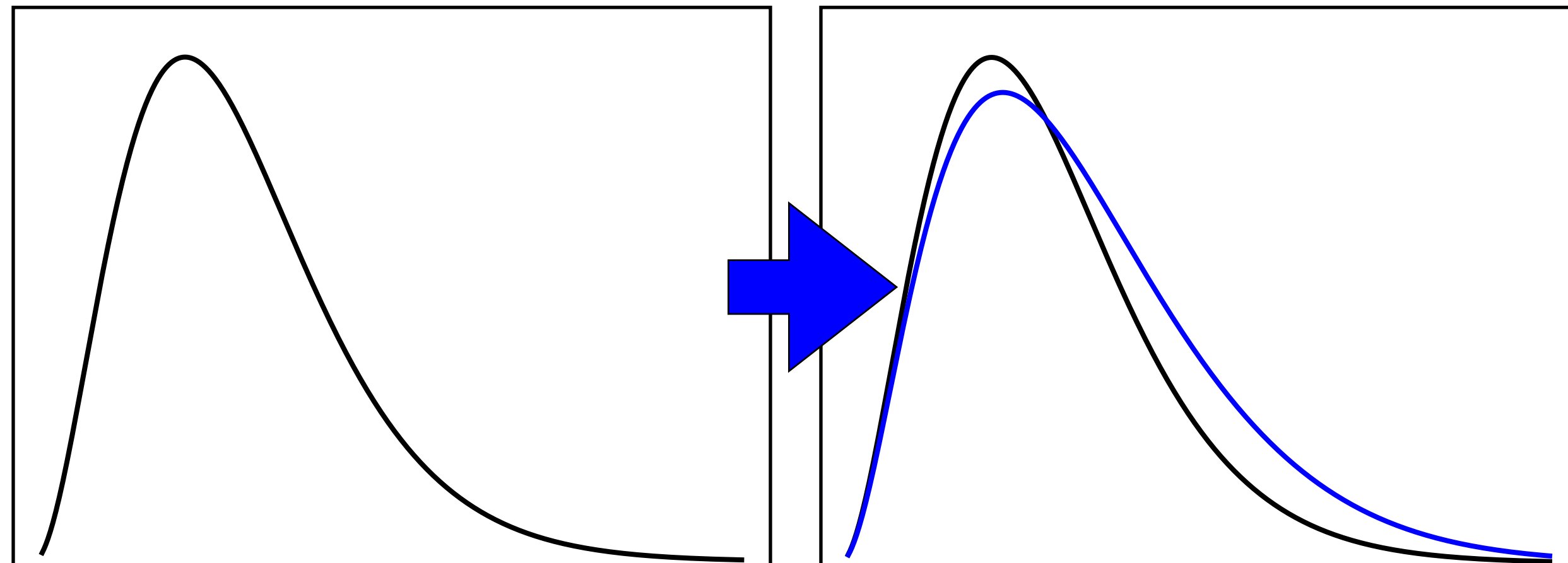

Thermalisation

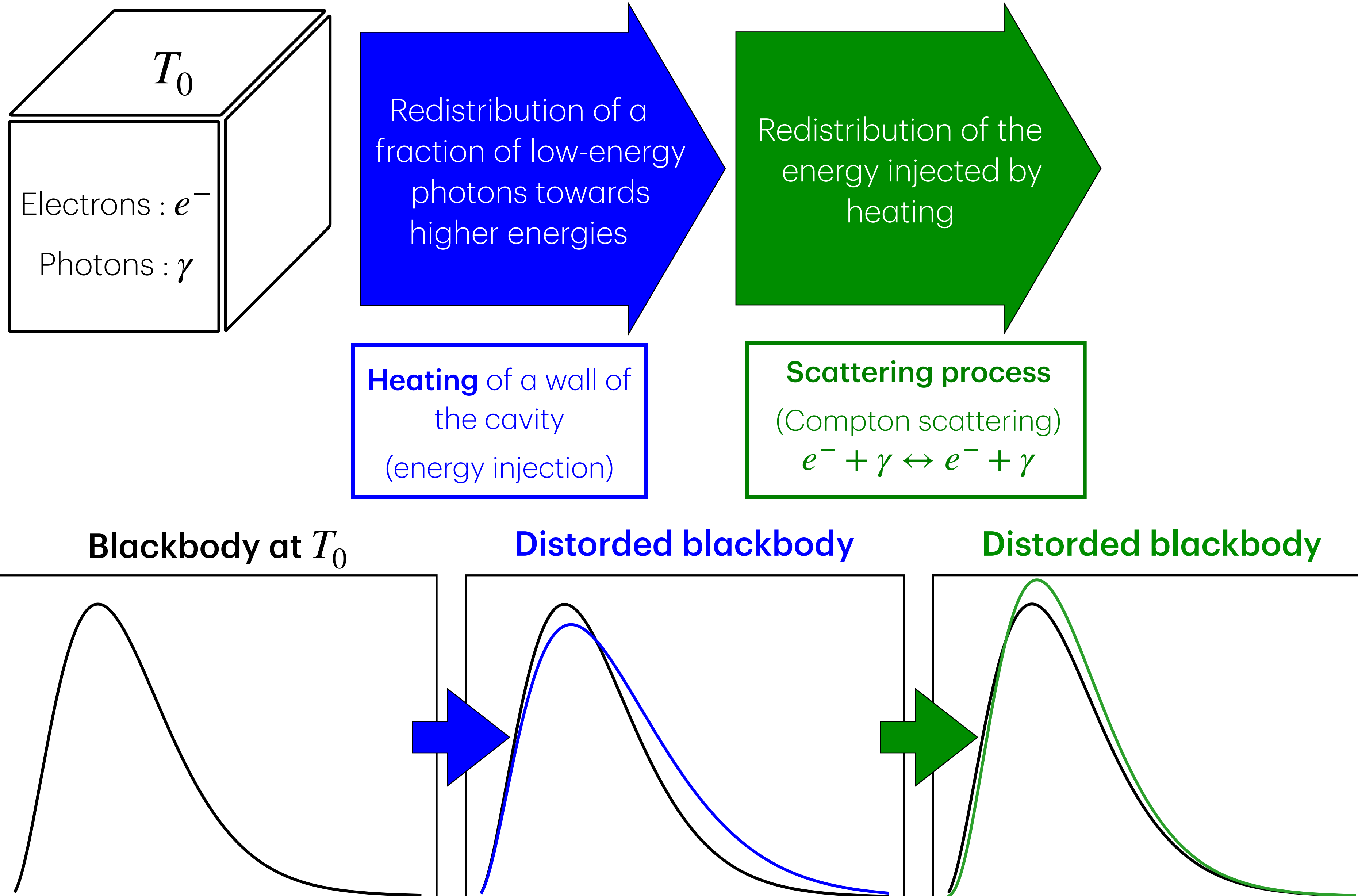

Thermalisation

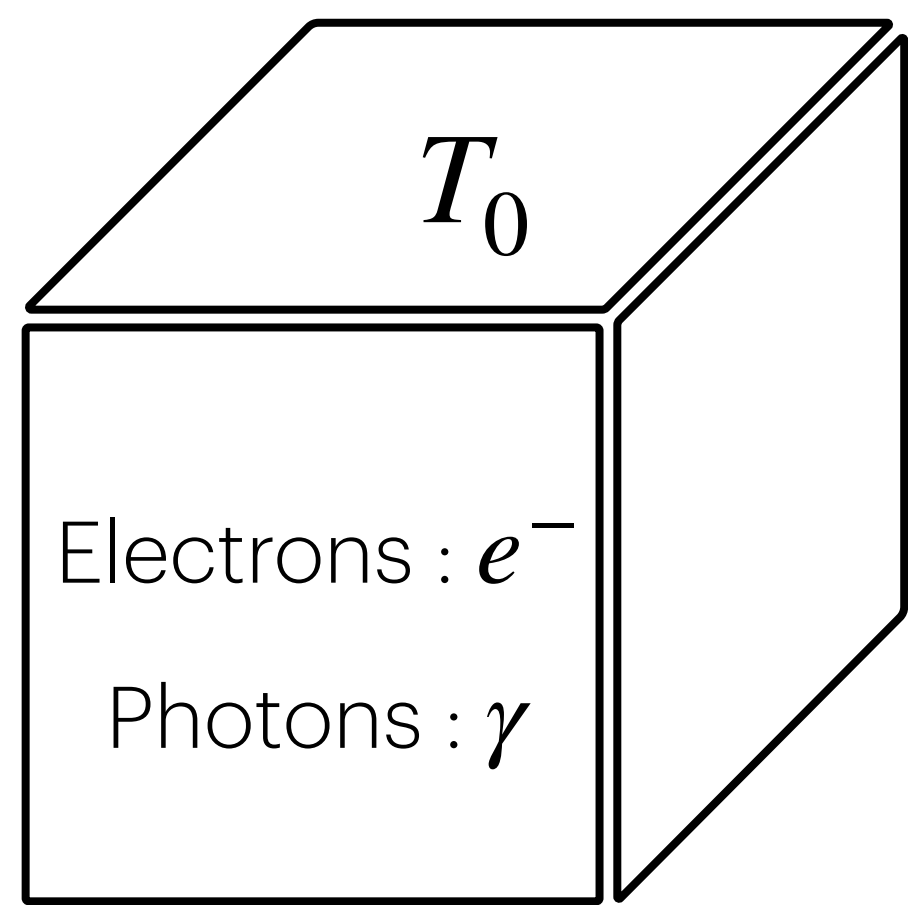

Redistribution of a fraction of low-energy photons towards higher energies

Redistribution of the energy injected by heating

Heating of a wall of the cavity
(energy injection)

Scattering process
(Compton scattering)
 $e^- + \gamma \leftrightarrow e^- + \gamma$

Number changing process
(Bremsstrahlung)
 $e^- + \gamma \leftrightarrow e^- + \gamma + \gamma$

Blackbody at T_0

Distorted blackbody

Distorted blackbody

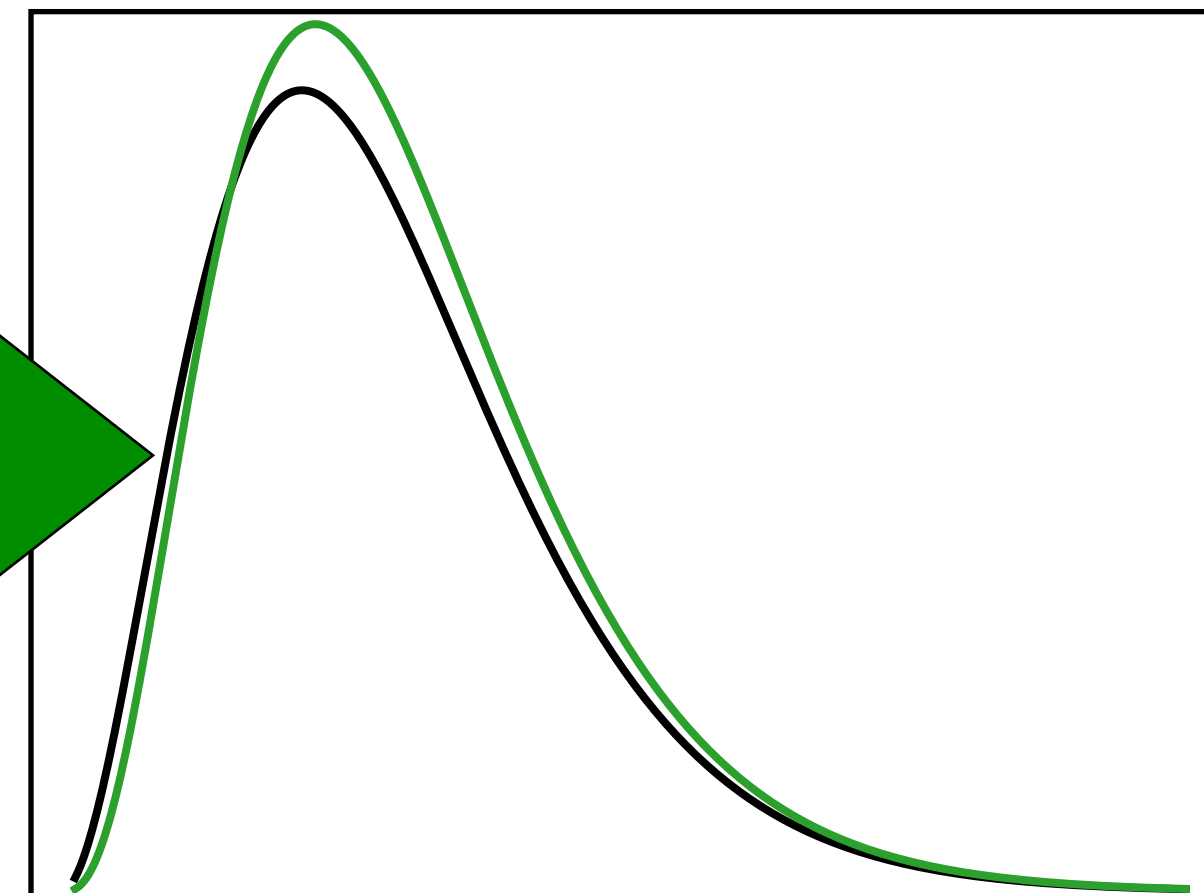
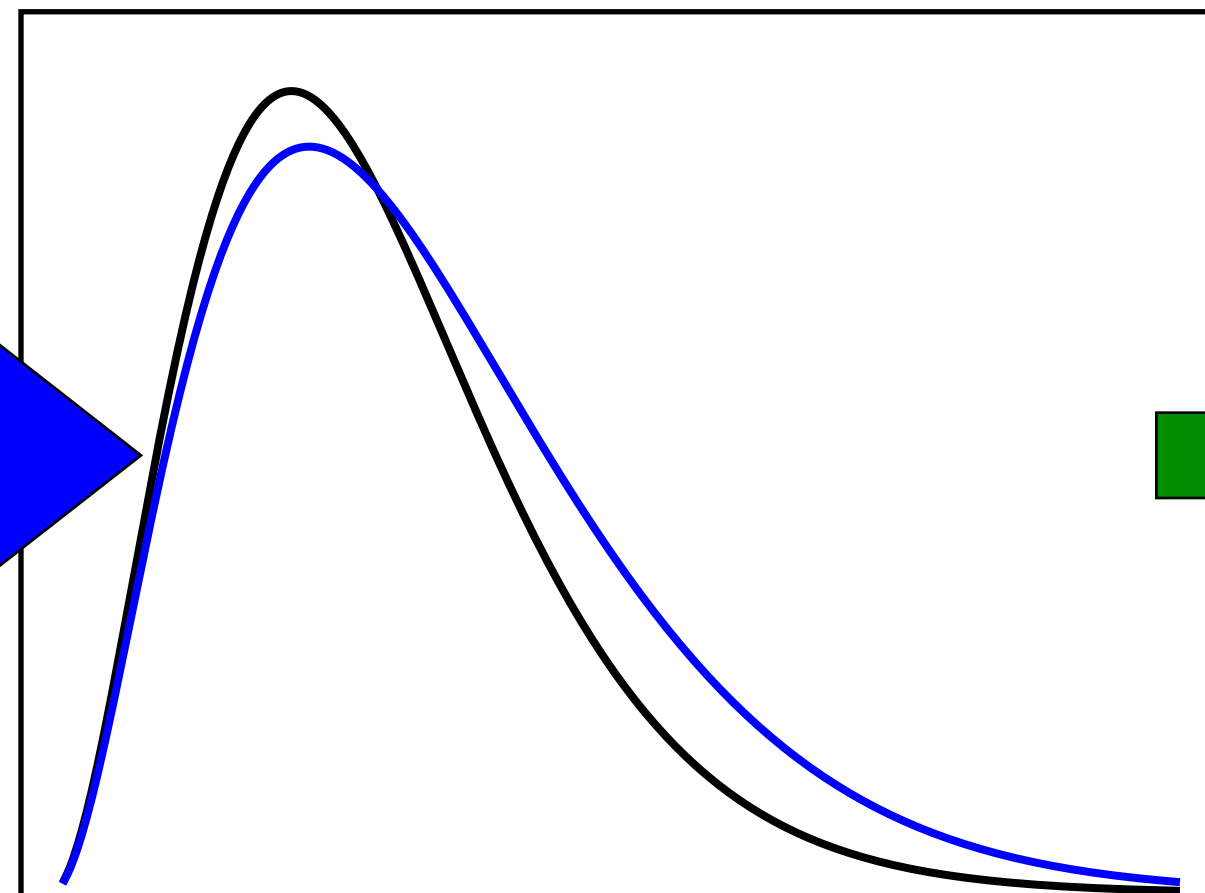
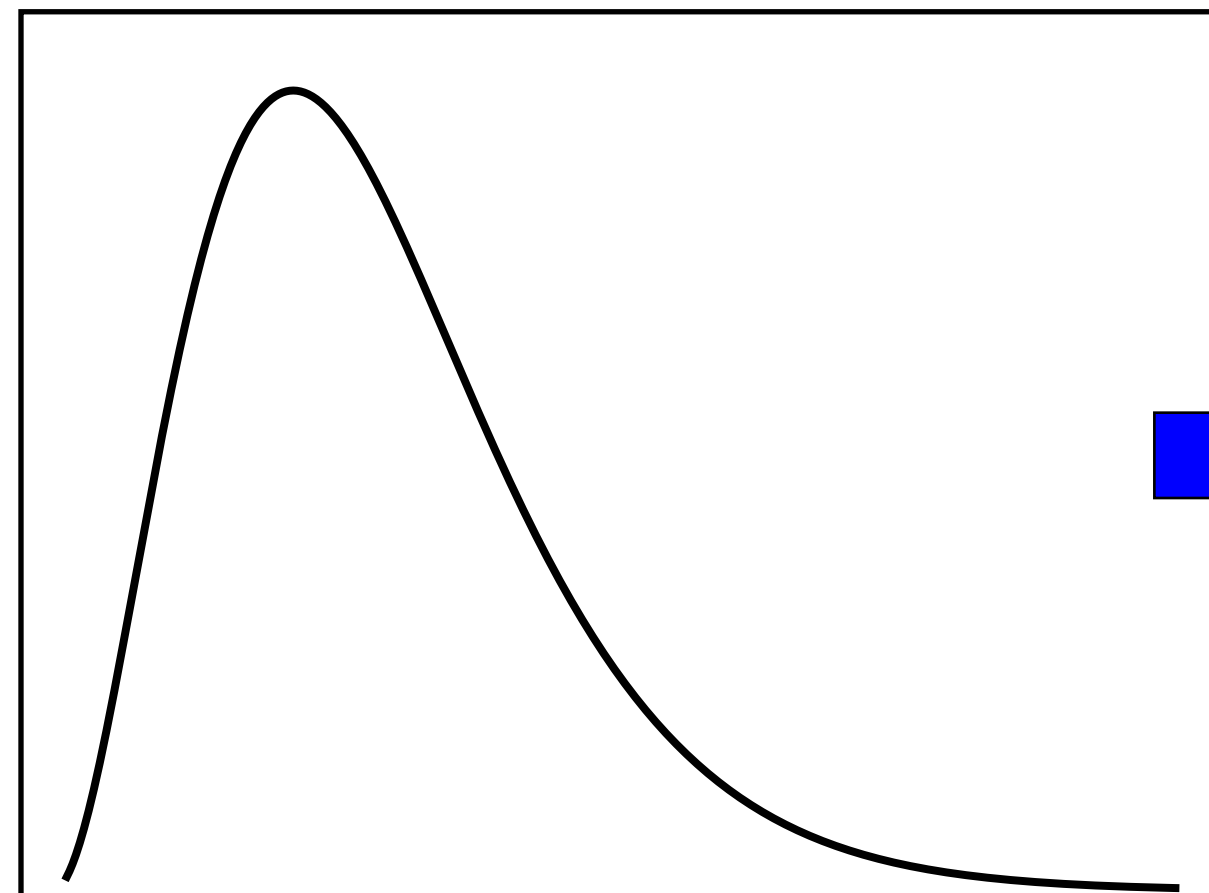

Thermalisation

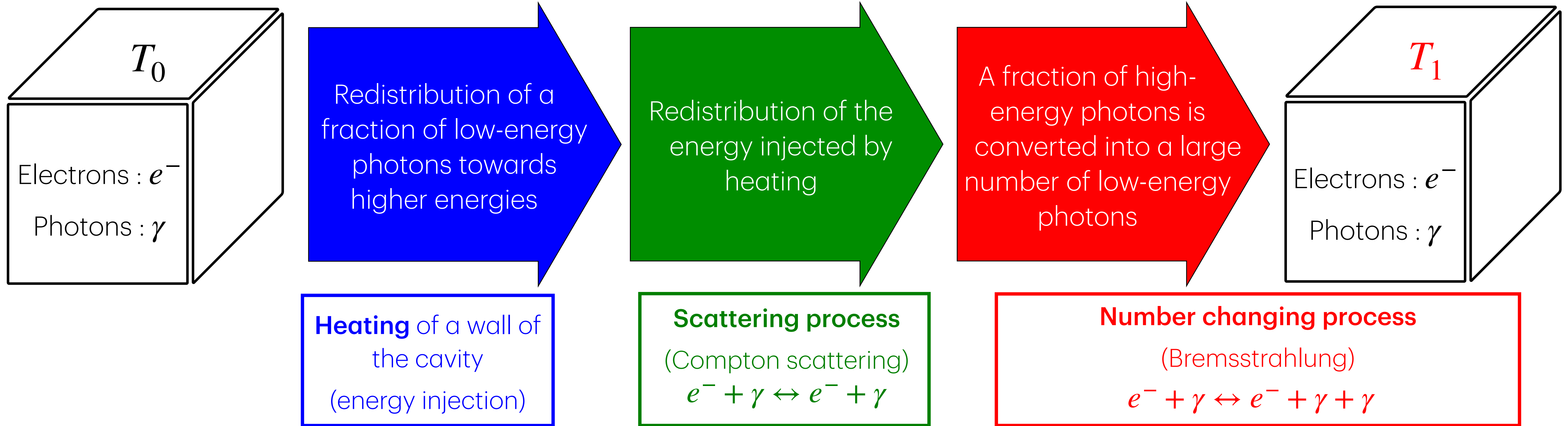

Blackbody at T_0

Distorted blackbody

Distorted blackbody

Blackbody at T_1

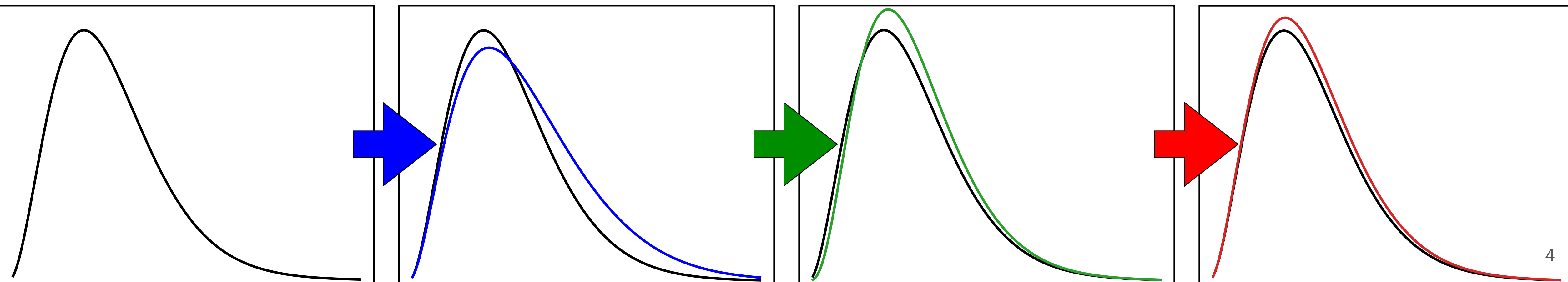

Thermalisation in the early Universe

Inflation 2 months

$$z > 2 \times 10^6$$

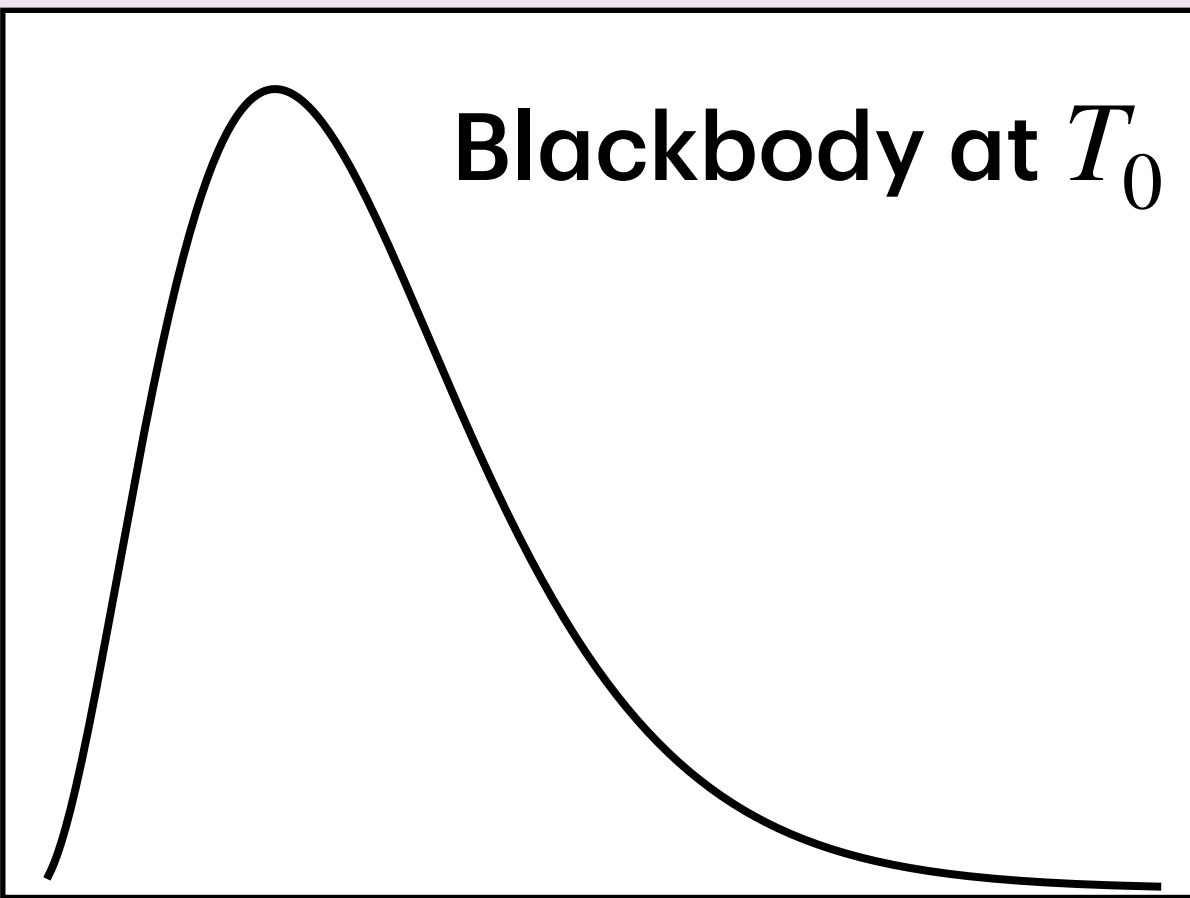

Compton scattering

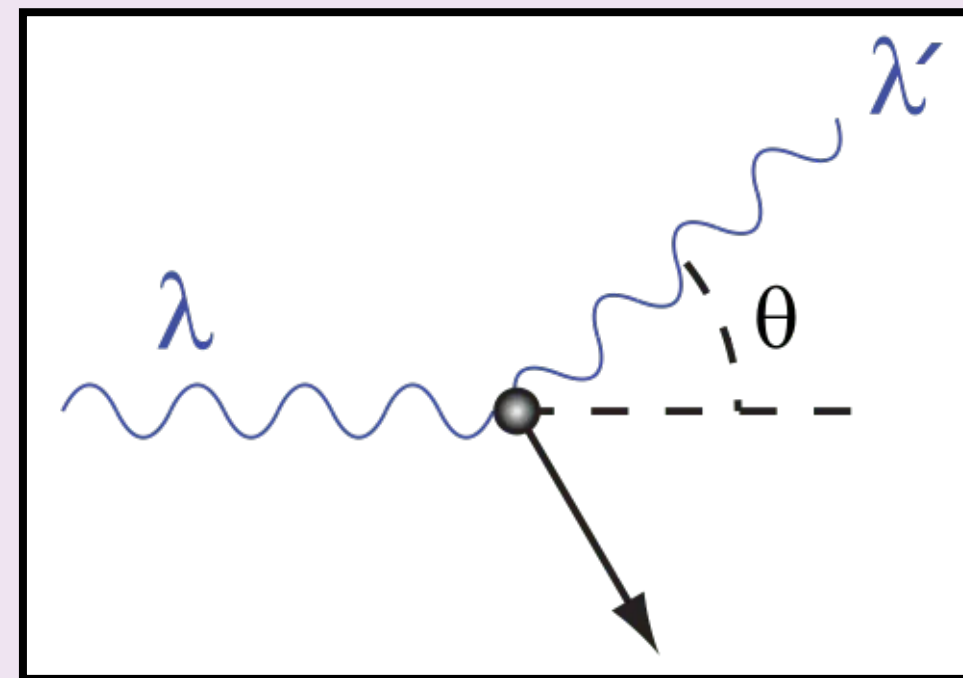

Bremsstrahlung

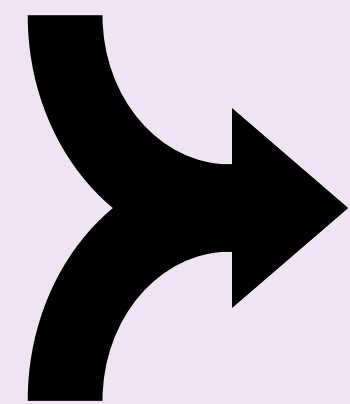
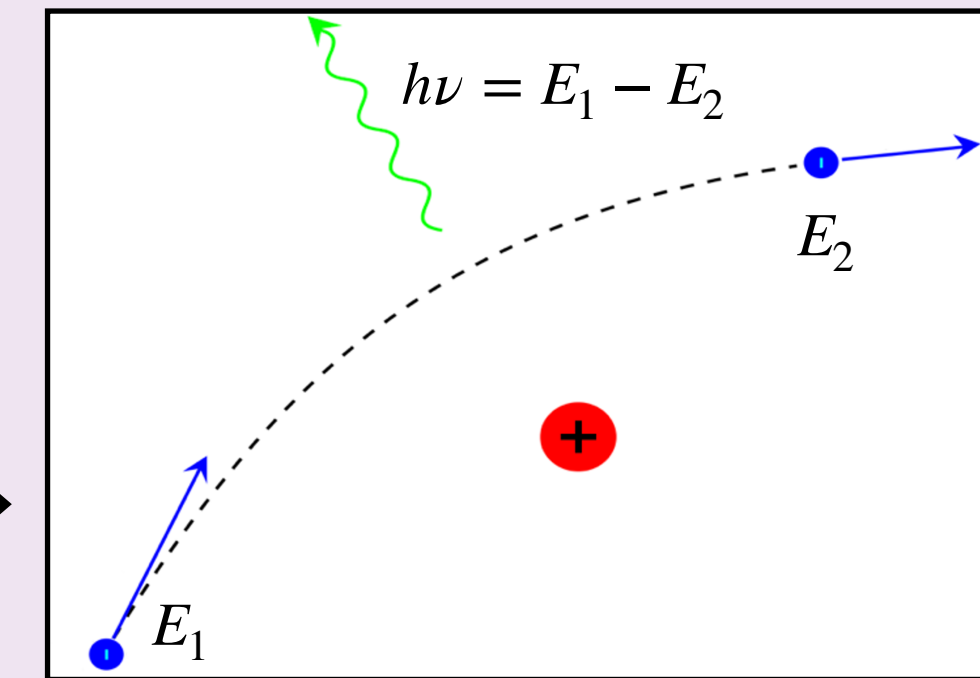

Energy injection

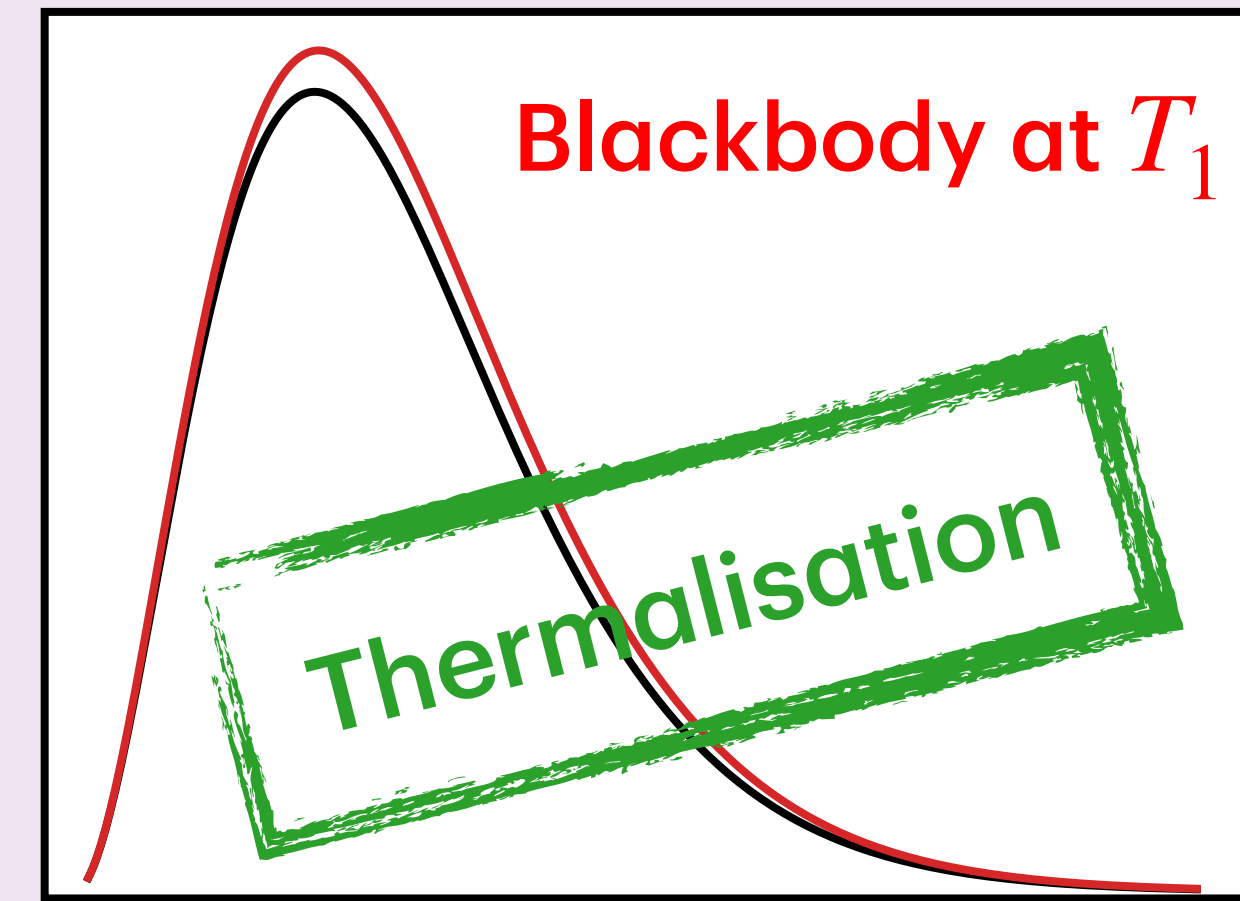
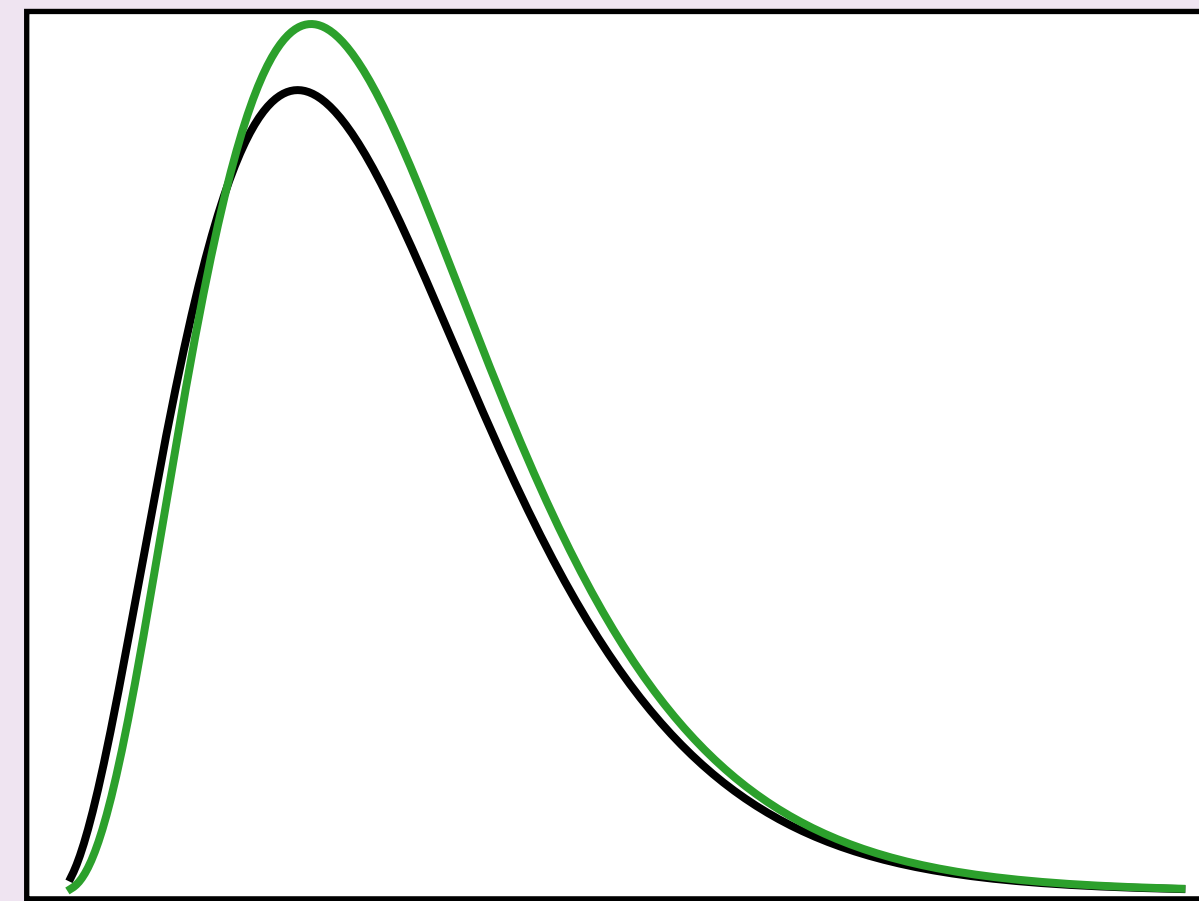
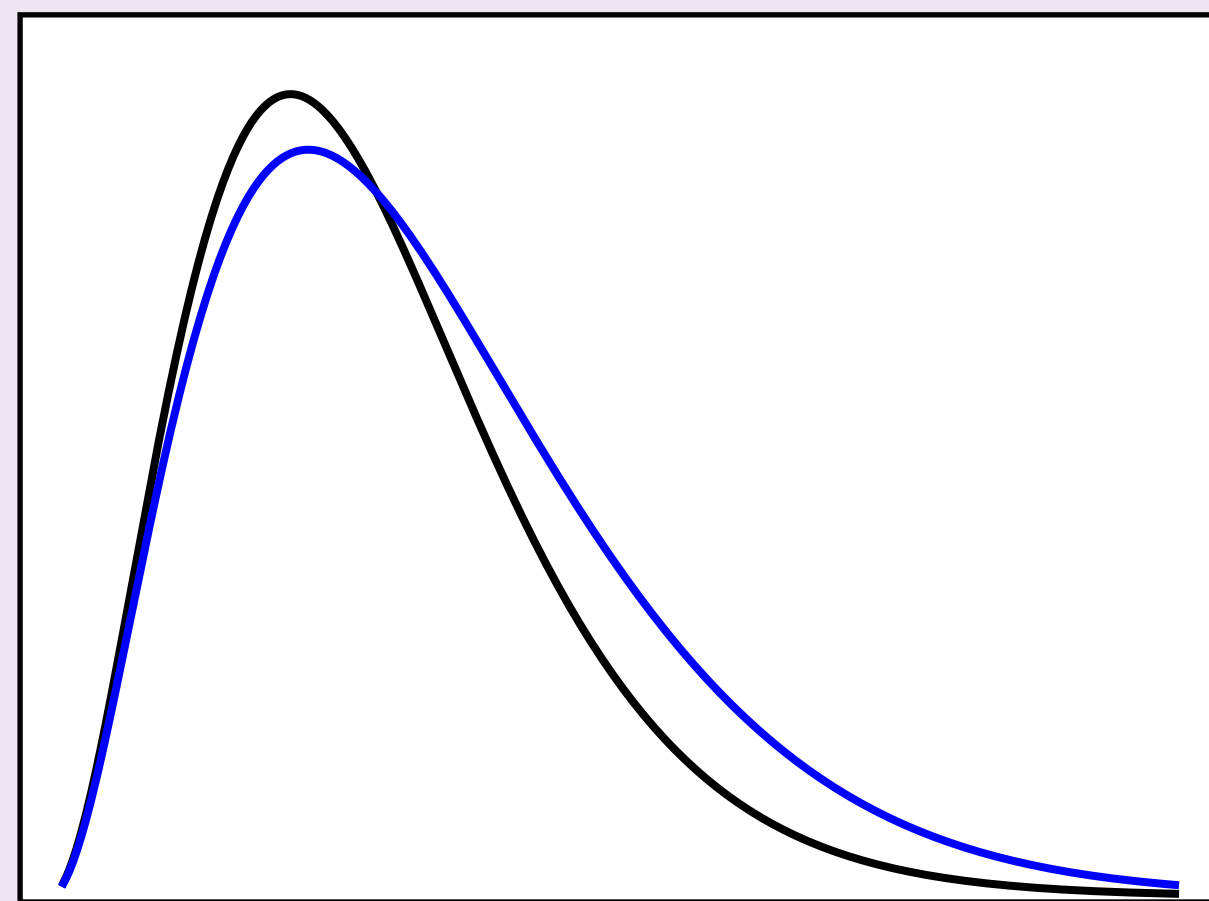

Spectral distortions in the early Universe

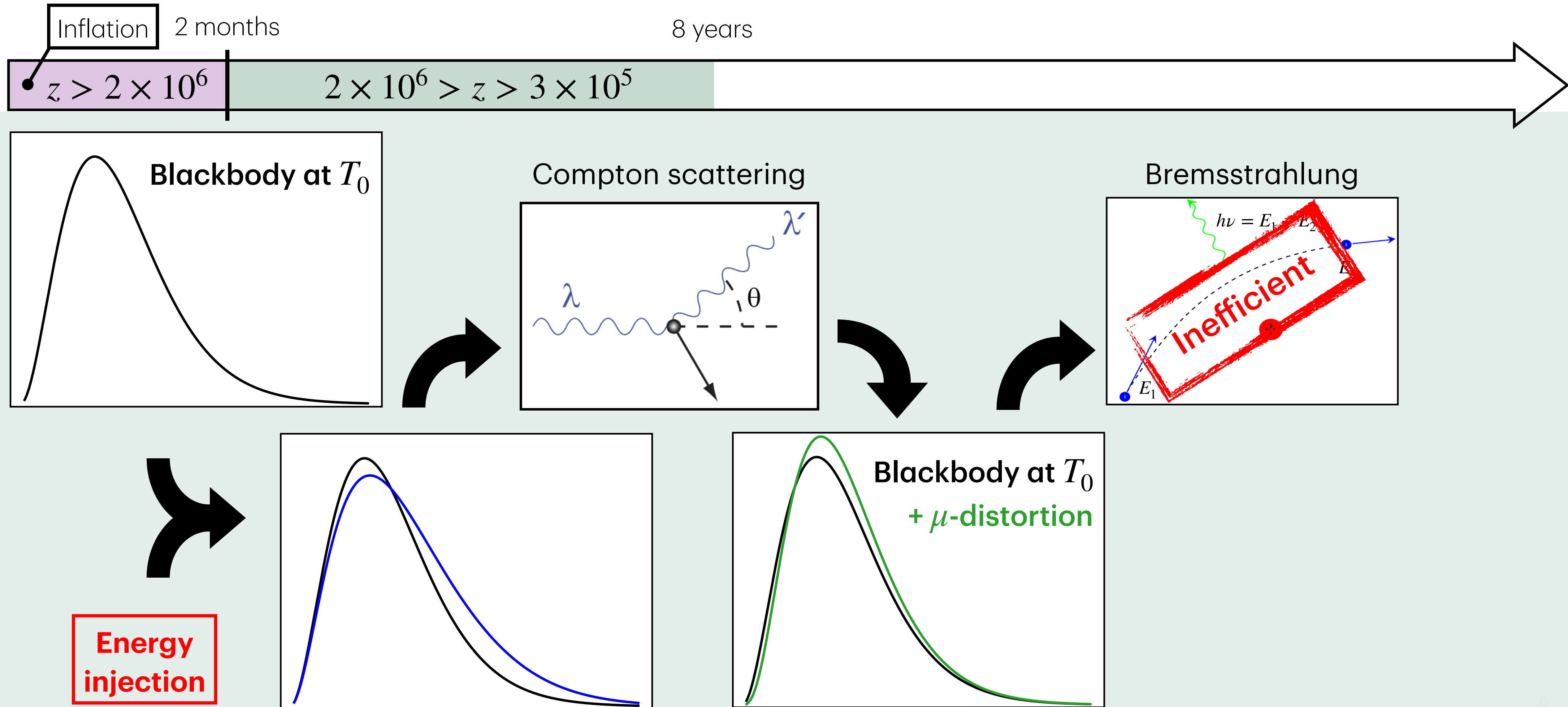

Spectral distortions in the late Universe

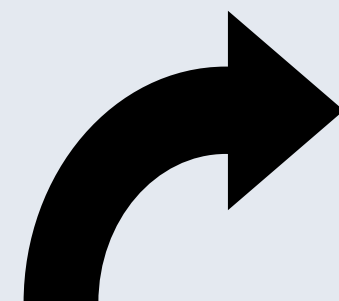
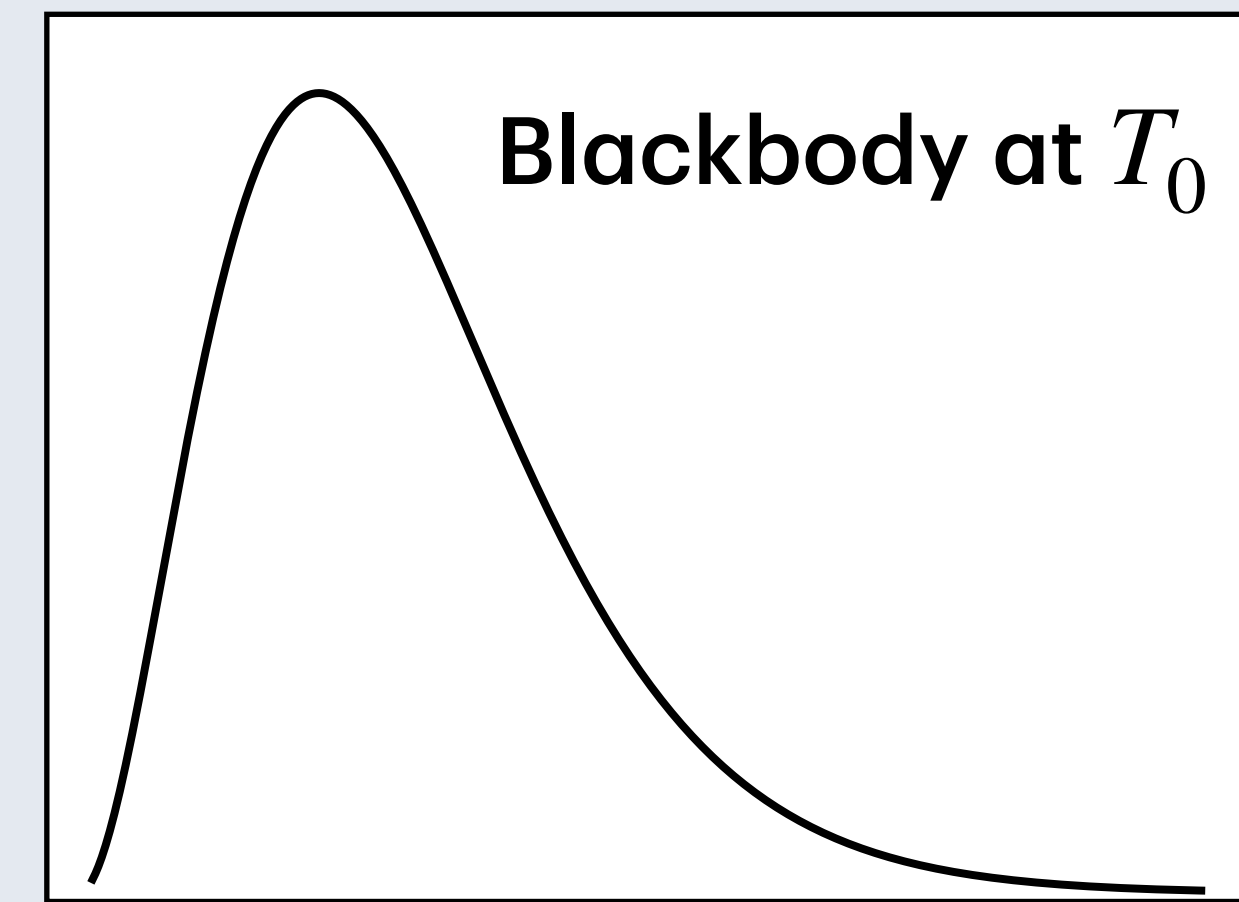
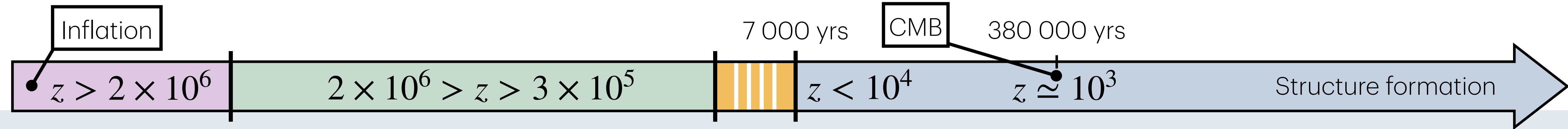

Compton scattering

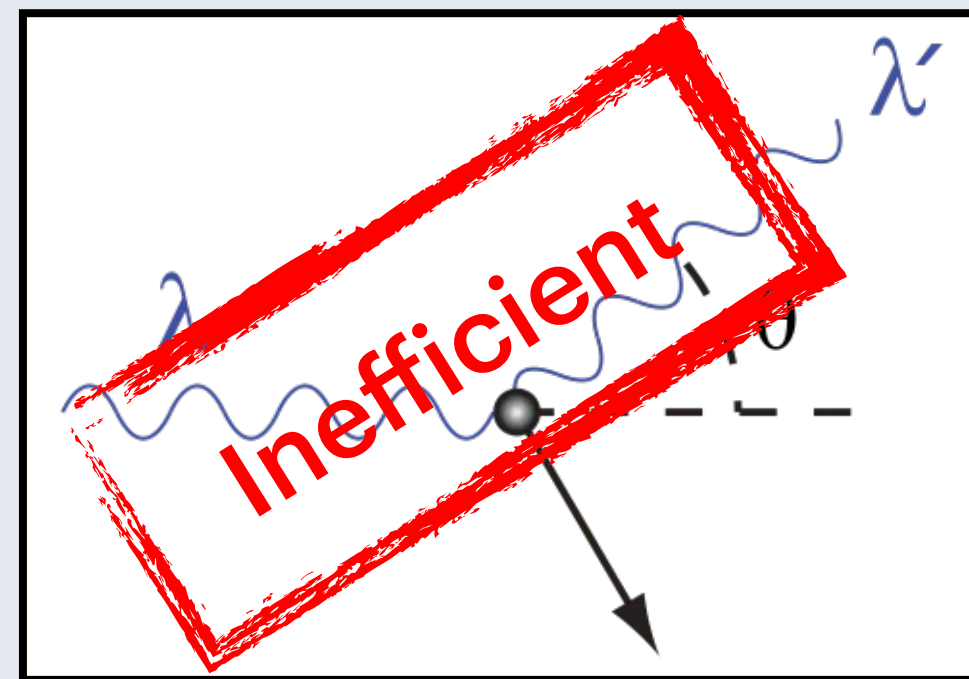

Bremsstrahlung

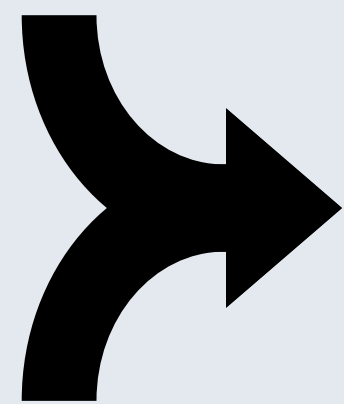
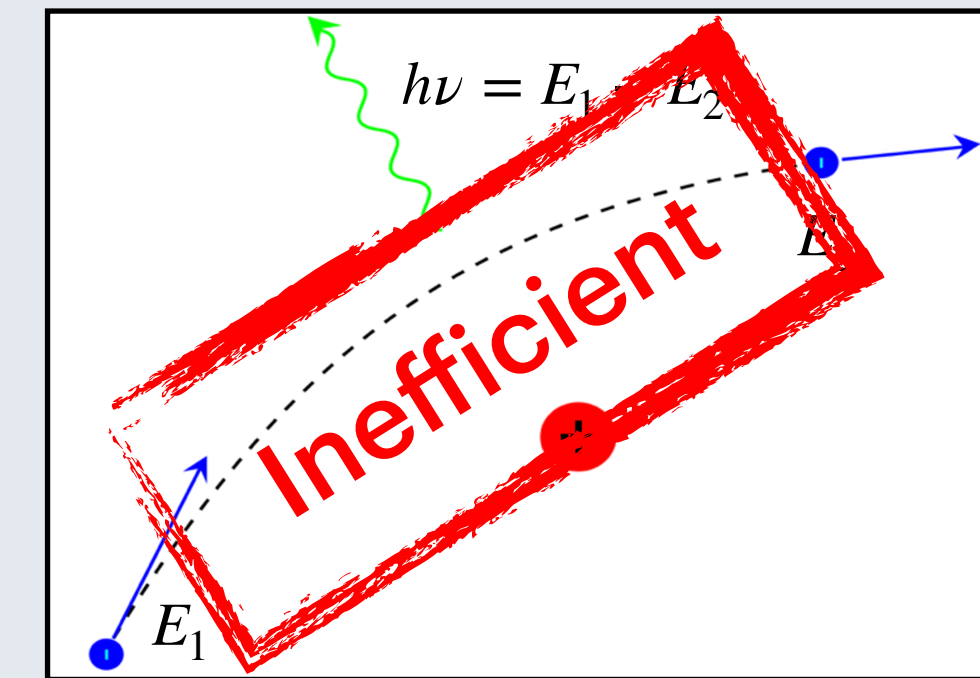

Energy injection

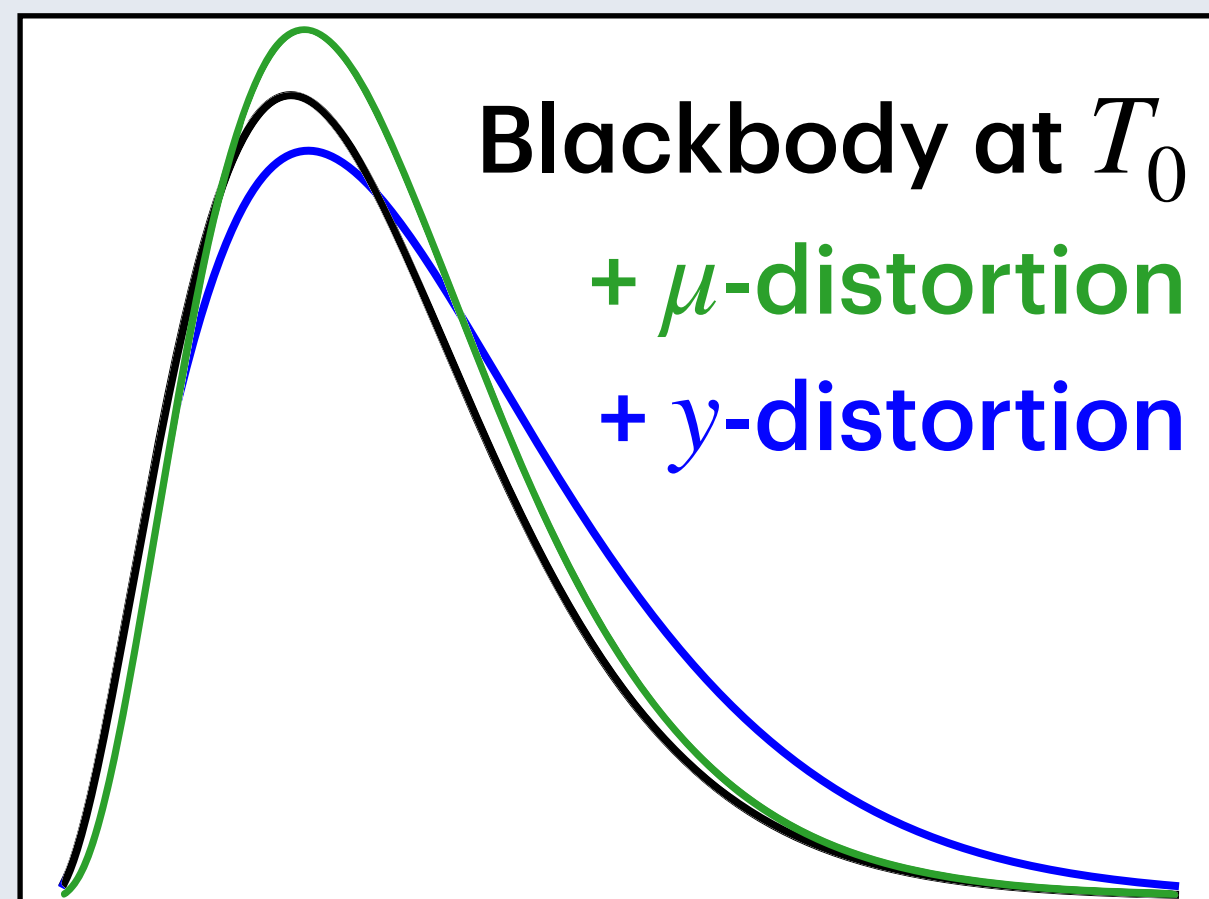

Cosmology with CMB spectral distortions

- How did the Universe begin?
 - What powered inflation?
 - Are there primordial BH?
 - Did they seeded the SMBH observed in almost all galaxies?

Dissipation of evolving initial perturbation from standard inflation

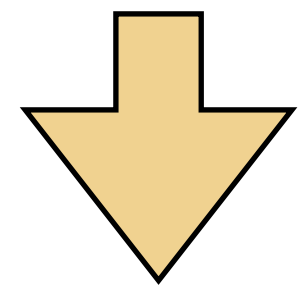

CMB spectral distortion
 $\mu = 2 \times 10^{-8}$

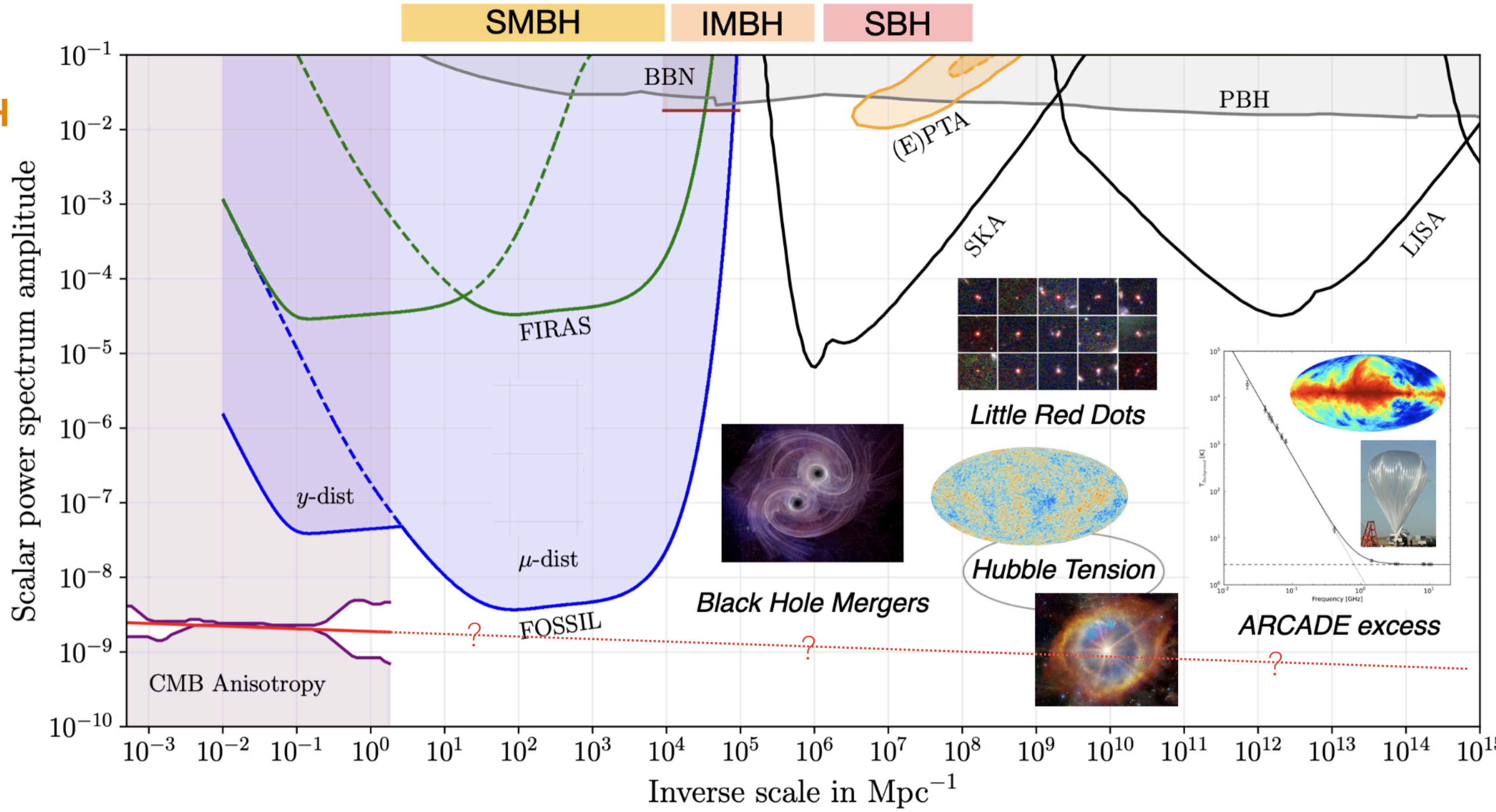

FOSSIL proposal - Adapted from Cry+2024

Cosmology with CMB spectral distortions

- What is the Universe made of?

- What is dark matter nature?
- What is dark energy?

Dark matter decay, annihilation and scattering with standard model particles

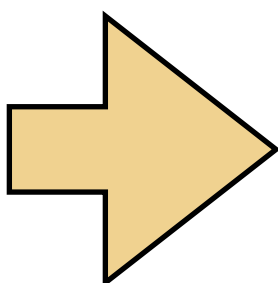

Spectral distortions

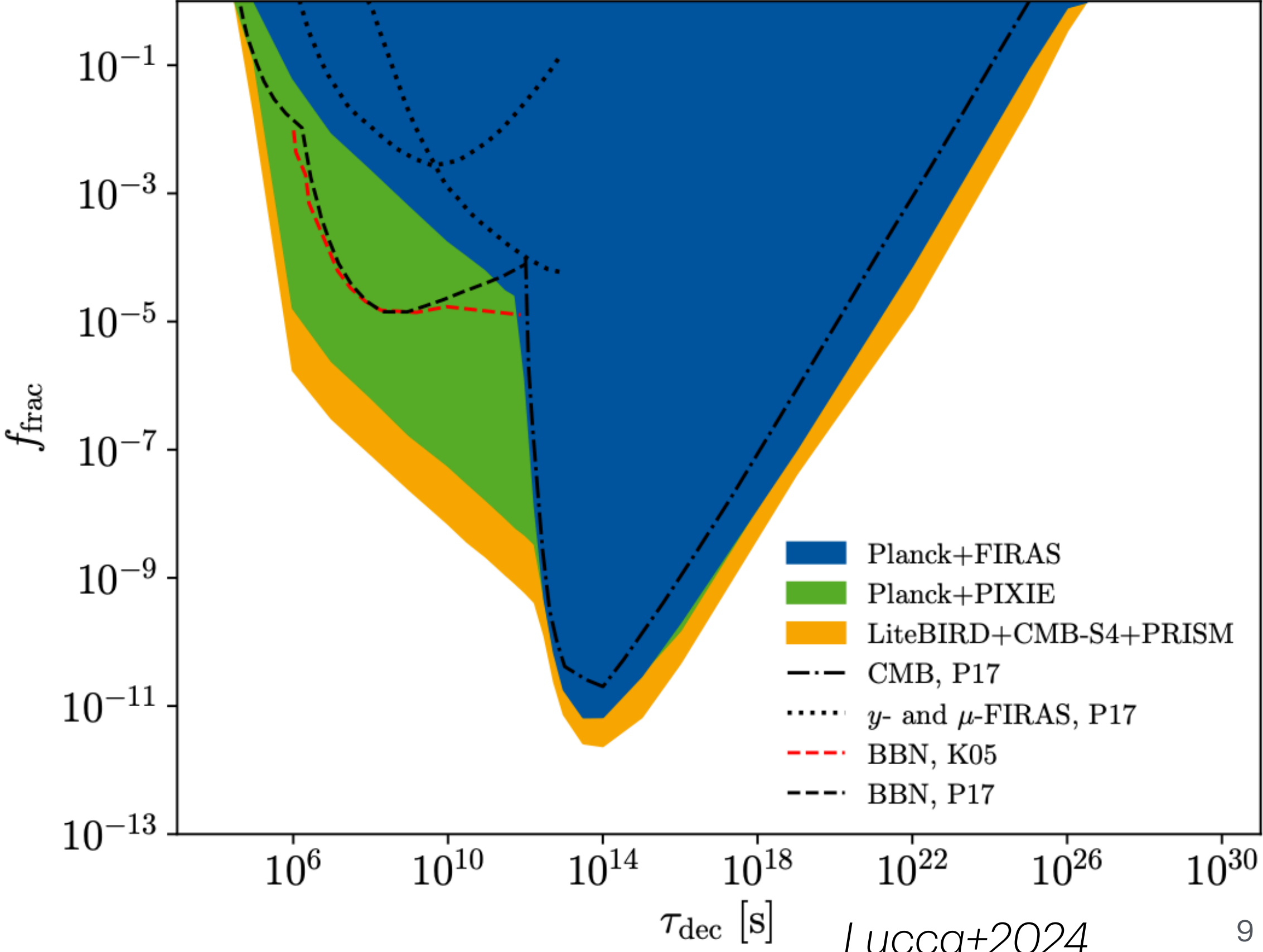
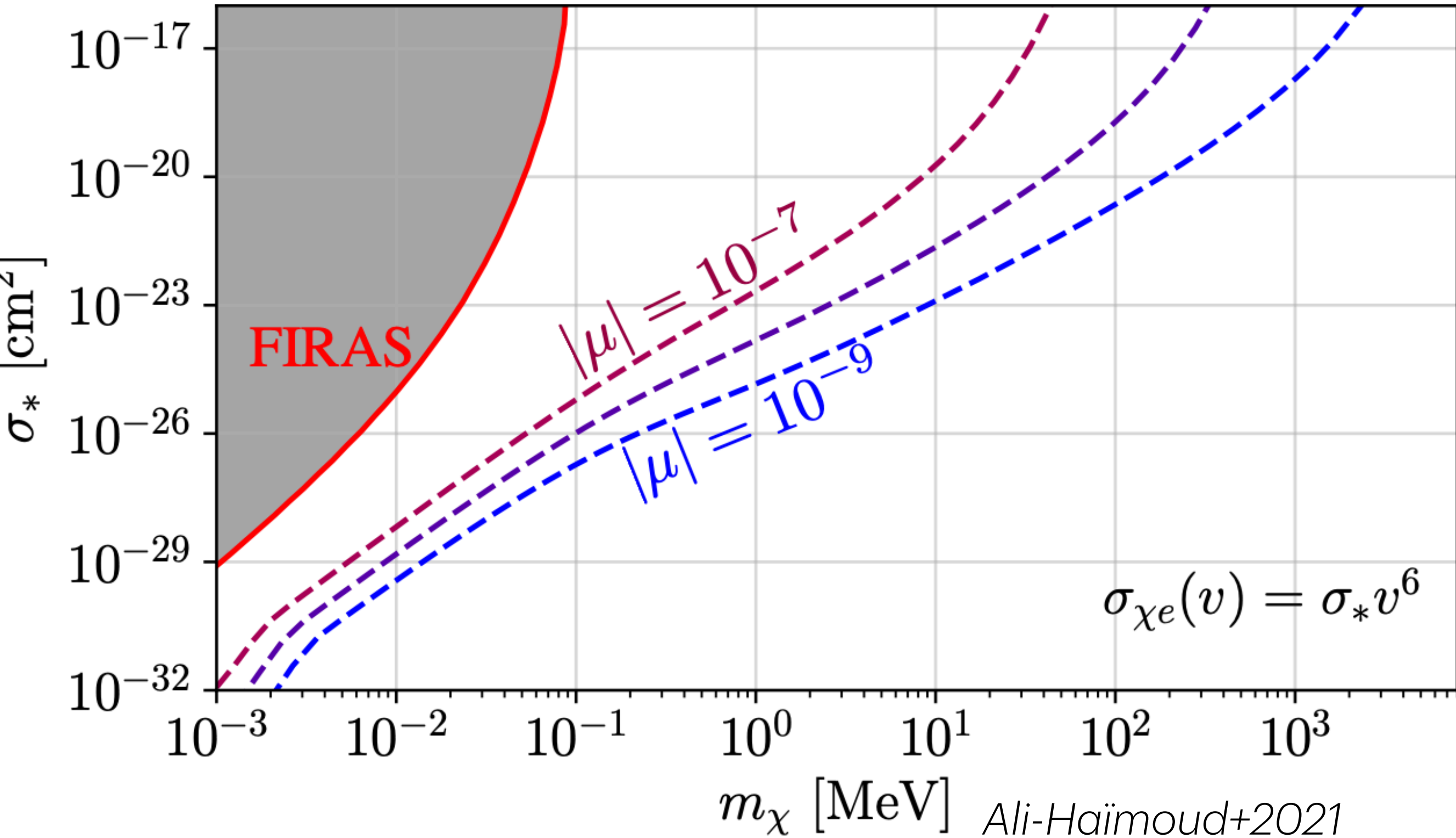

Cosmology with CMB spectral distortions

- How did the Universe evolve?
 - What is the thermal energy in the large-scale structure?

Energy release from collapse of baryons, feedback processes and reionisation

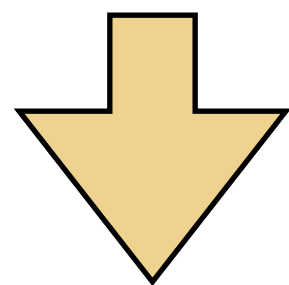

y-type spectral distortions in relativistic and non-relativistic regime

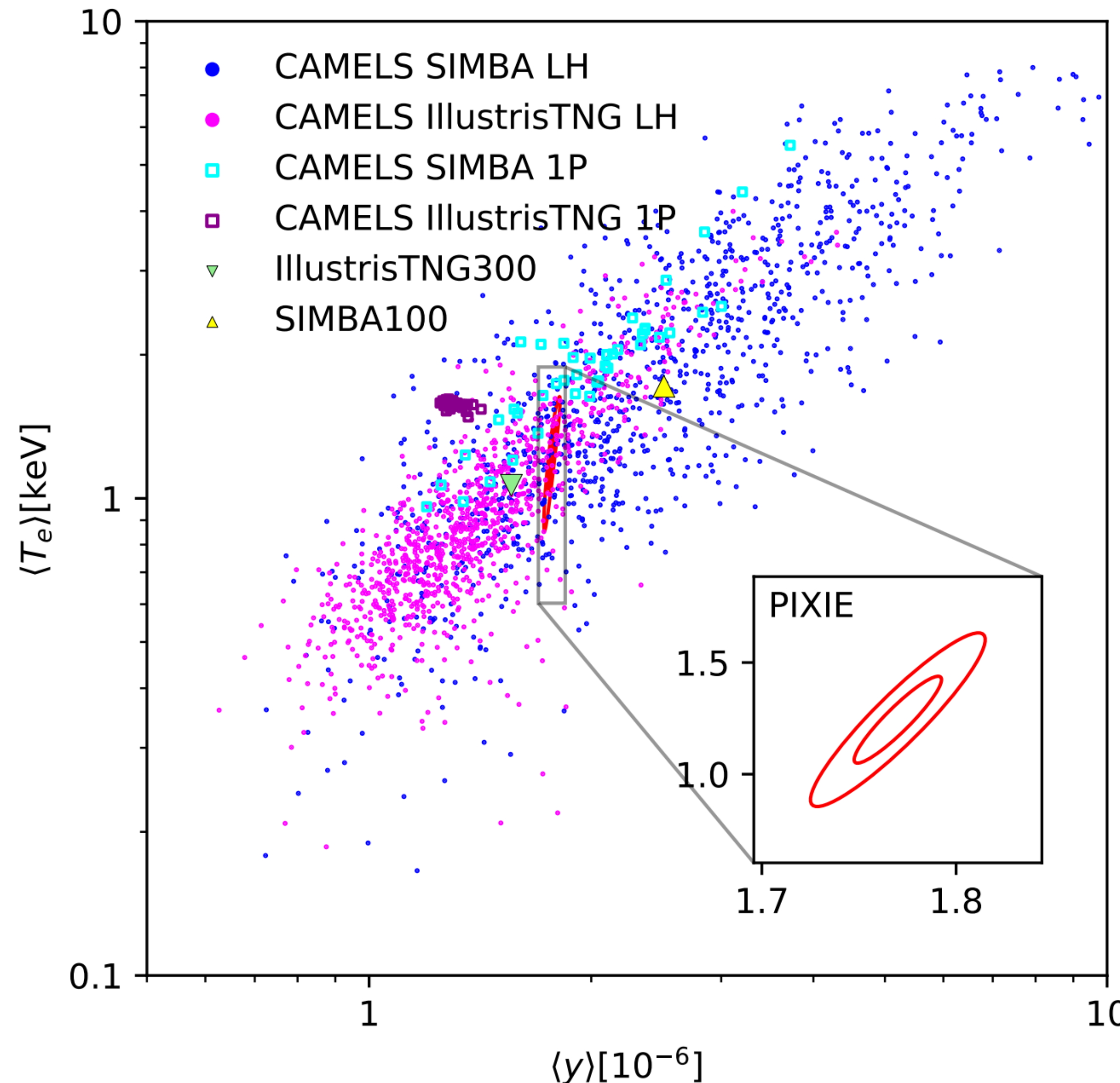

Thiele+2022

Many other examples can be found in the **ESA Voyage 2050 White Paper** (Chluba et al. 2021)

Measuring CMB spectral distortions

- Angular resolution
 - Non-critical since measurement of CMB monopole
- High sensitivity
 - Very faint signals
- Wide frequency coverage
 - To separate sky components
- Spectral resolution
 - To separate sky components
- Absolute measurement
 - To measure relative to a reference blackbody spectrum

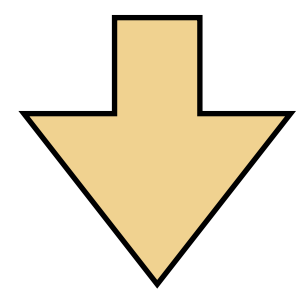

- **Fourier Transform Spectrometer (FTS)**
in Martin-Puplett configuration

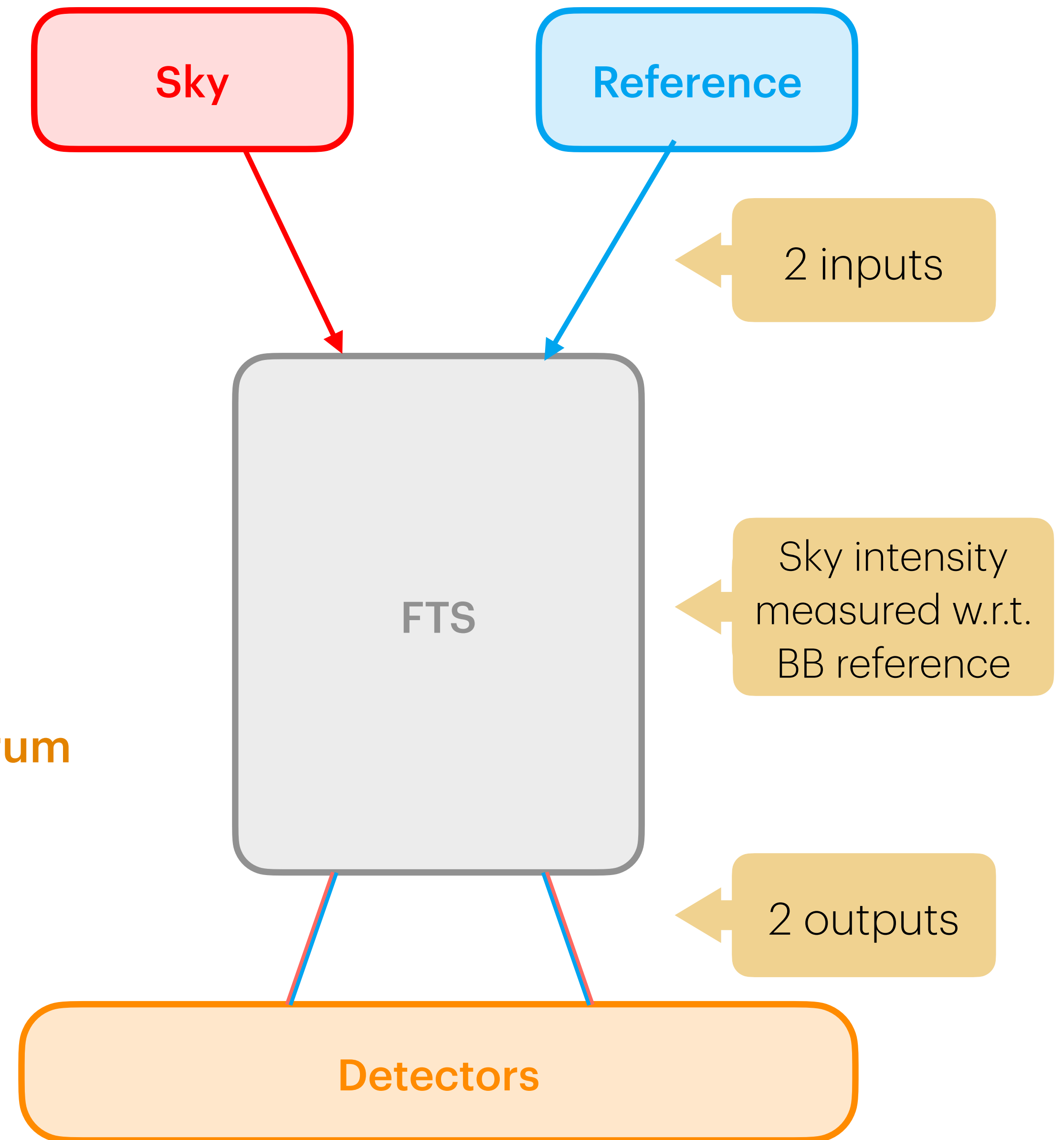

Measurement principle with an M.-P. FTS

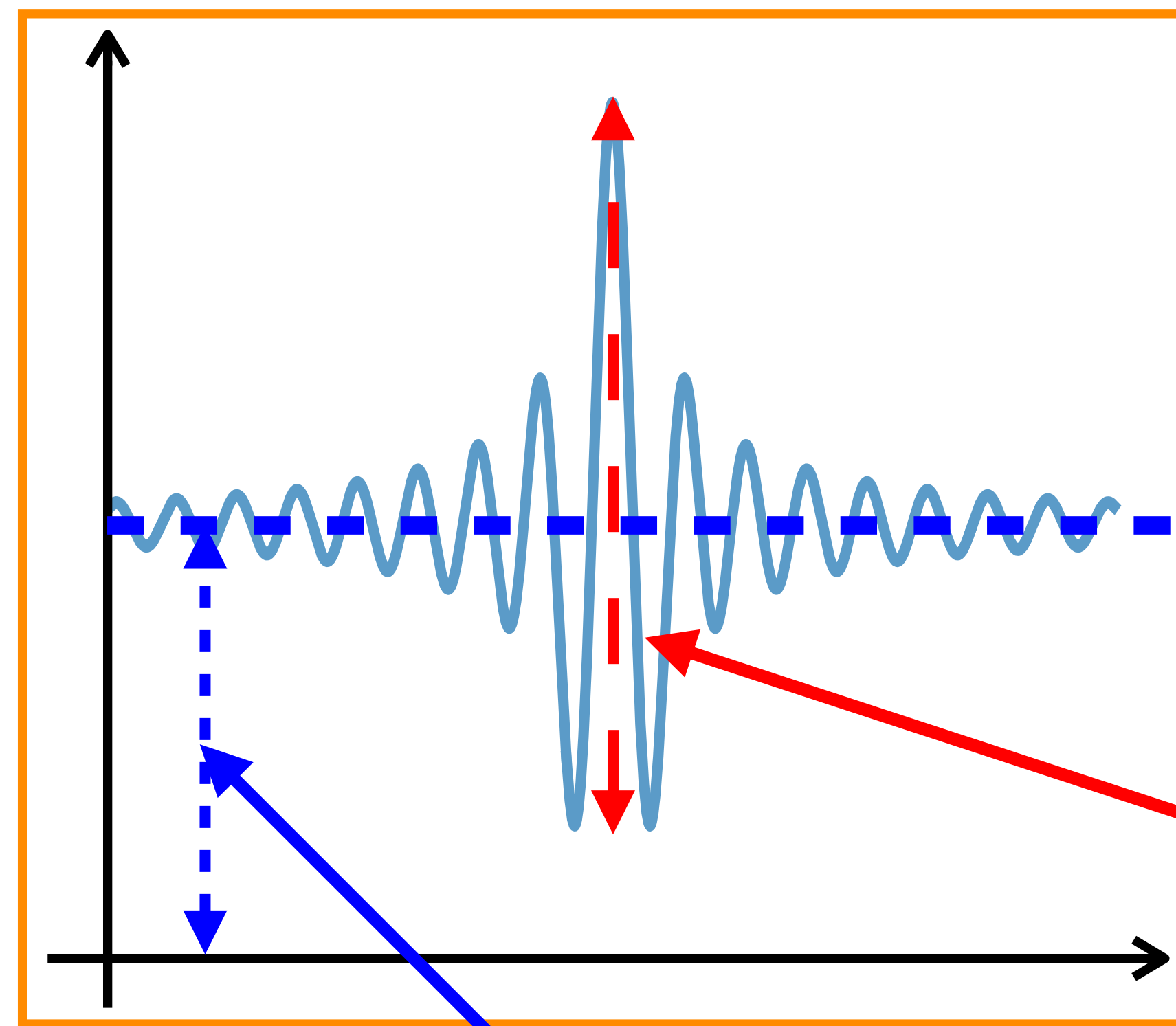
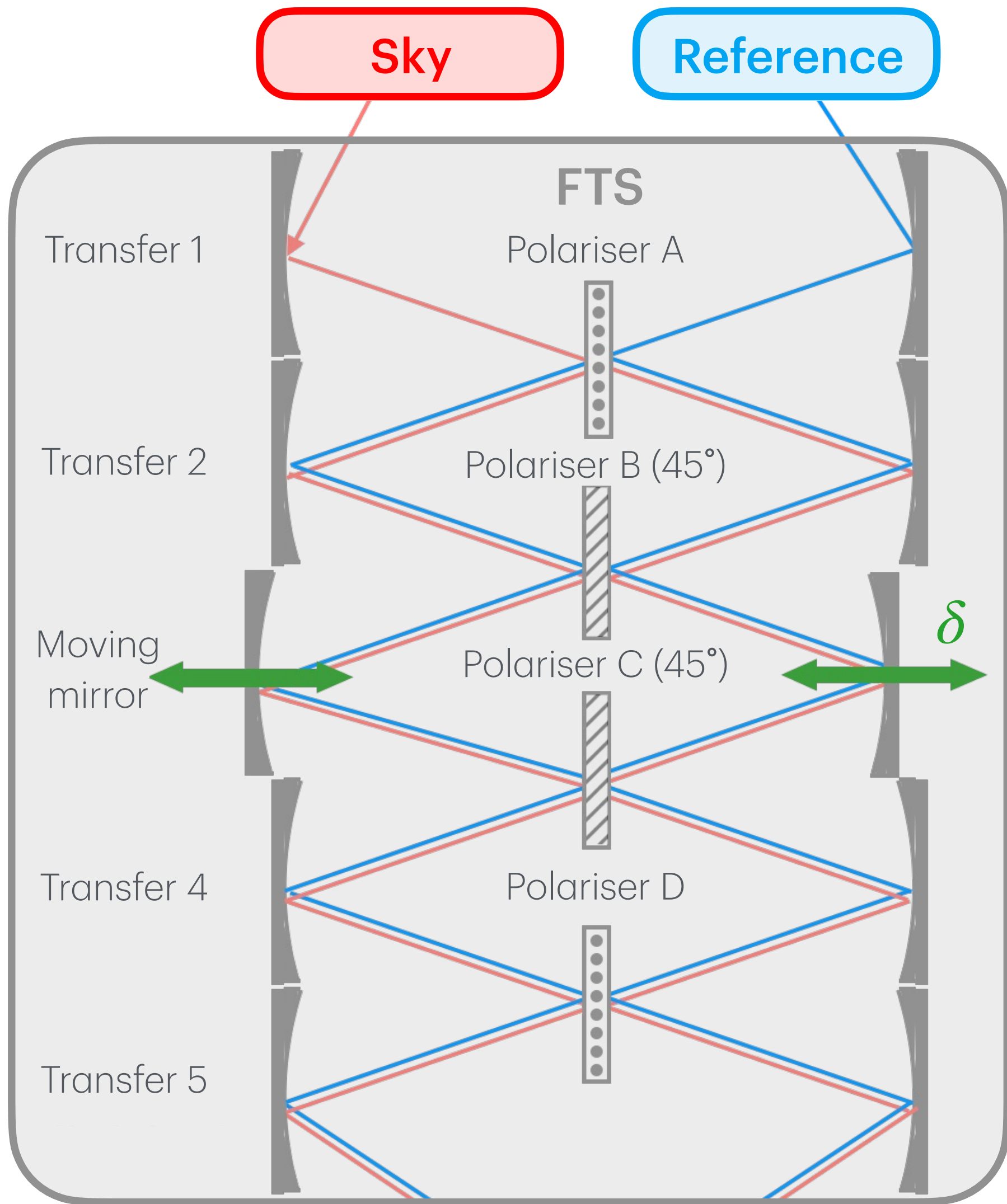

Difference between the emission spectrum of the sky and that of the reference

FFT

$$\propto I_{sky} - I_{ref}$$

$$\propto I_{sky} + I_{ref}$$

$$P_L = C + \frac{1}{4} \int (I_{sky} - I_{ref}) \cos\left(\frac{4\delta\omega}{c}\right) d\omega$$

$$P_R = C + \frac{1}{4} \int (I_{ref} - I_{sky}) \cos\left(\frac{4\delta\omega}{c}\right) d\omega$$

Credits: M. Loquet Le Gall 2 Focal Plan Unit (FPU)

Toward CMB spectral distortion measurement



Tenerife **M**icrowave **S**pectrometer
(Rubiño-Martin et al)

Ground based spectrometer

Teide observatory



COSmic **M**onopole **O**bserver
(Masi et al)

Ground based spectrometer

Dome C - Antarctica



Balloon **I**nterferometer for **S**pectral
Observation of the primordial **U**niverse
(Maffei et al)

Balloon-borne spectrometer

+ Laboratory breadboard in development

BISOU Breadboard



BISOU Science flight
Summer 2031 or 2032

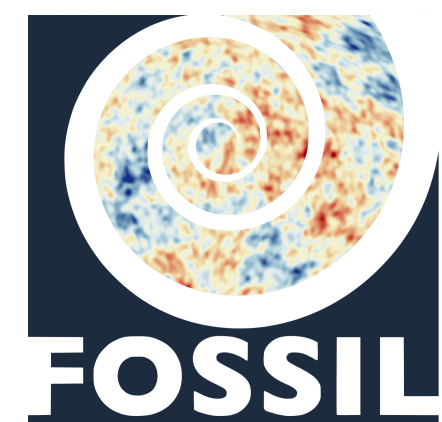

FTS for CMB **S**pectral di**S**tortion exp**L**oration
(Aghanim et al)

Space mission - ESA M8 proposal

M8 launch
2041₁₃

FOSSIL payload

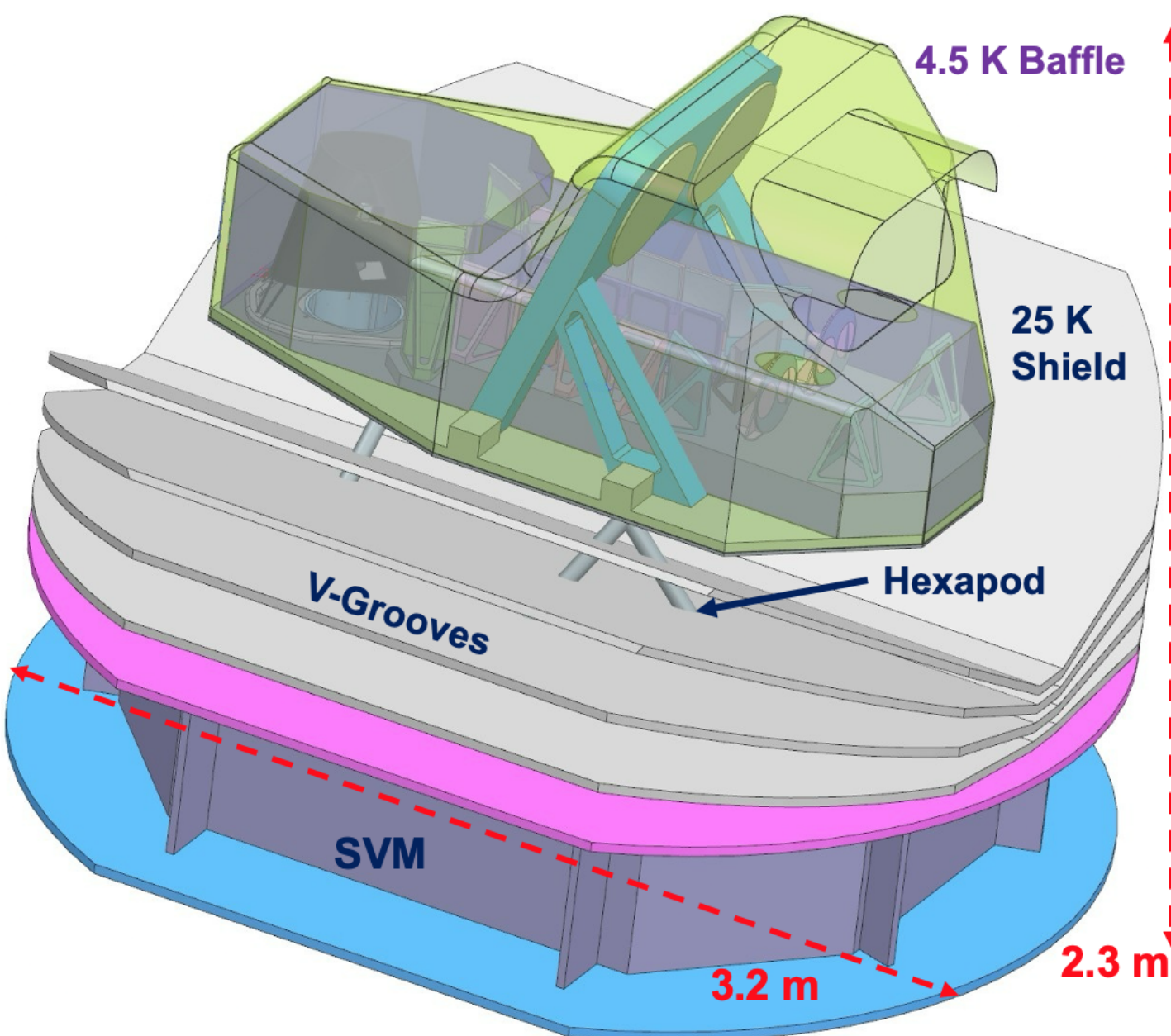
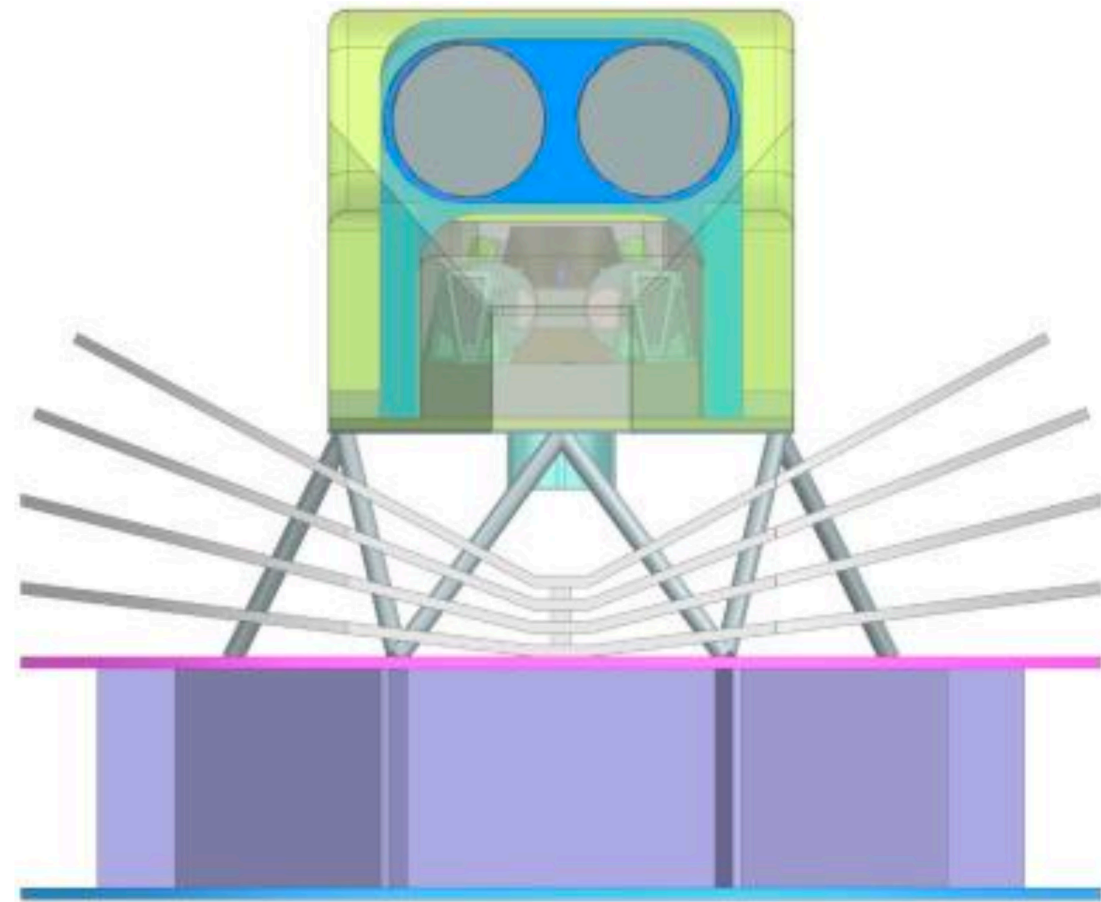
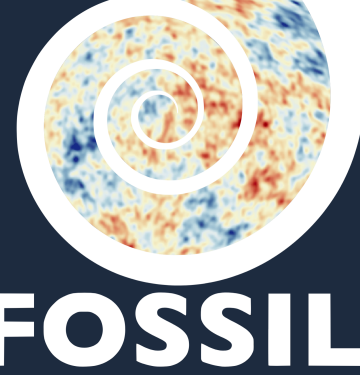

Instrumental concept:

- Full sky coverage from L2
- 50 GHz – 2 THz band
 - split @~300 GHz
- $\Delta\nu = 15$ GHz
- ~1.6 deg eq. Gaussian beam
- Instrument & telescopes cooled at ~4.5 K
- 2 telescopes: 40cm primary aperture
- 2 spectral bands per FTS output
 - 4 FPUs
- Multimoded feedhorn coupled detectors
 - operating @~50mK
 - Kinetic Inductance Detectors
- BB internal reference @2.5 - 2.9 K

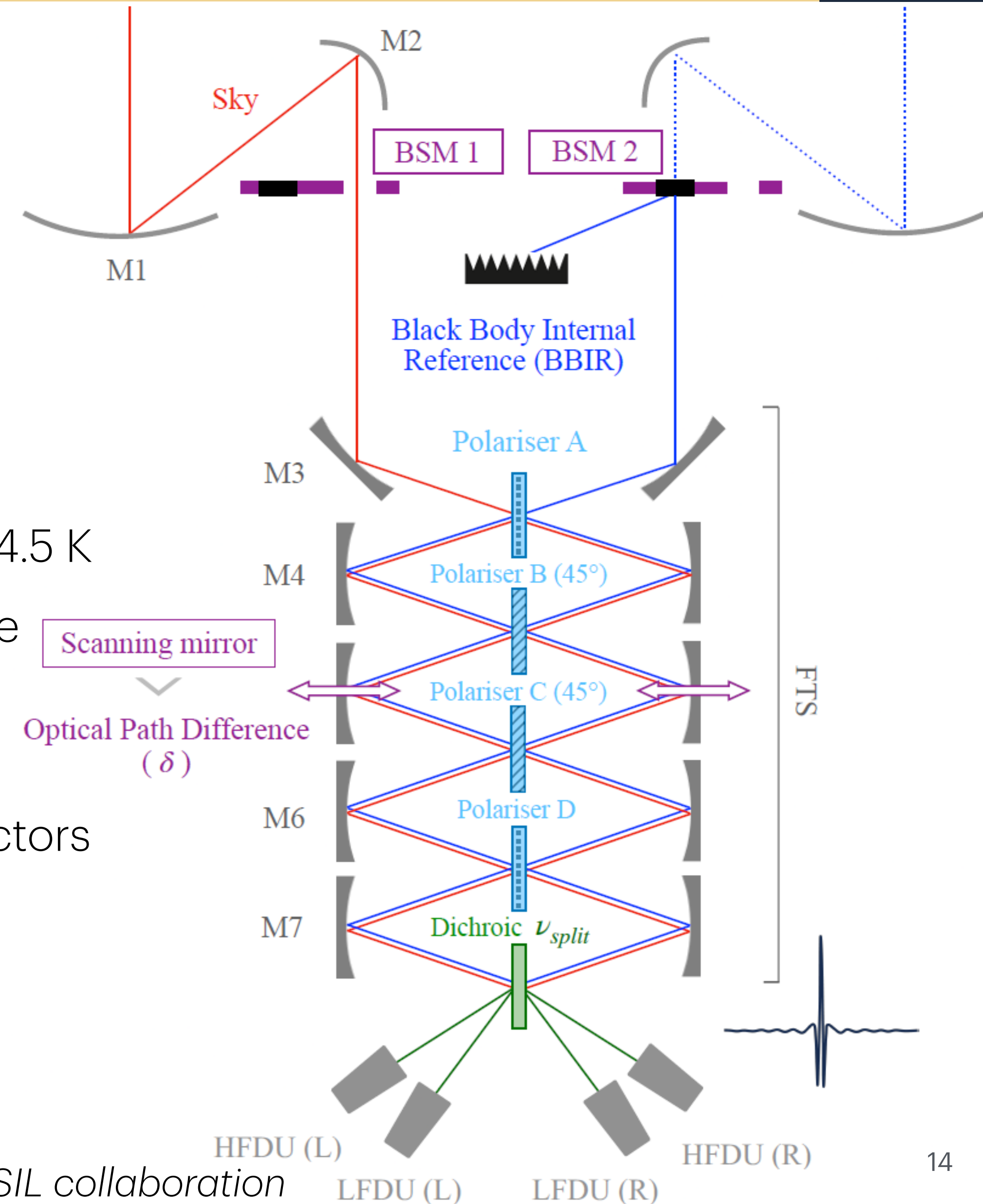

Credits: M. Loquet Le Gall, B. Borgo and FOSSIL collaboration

BISOU payload

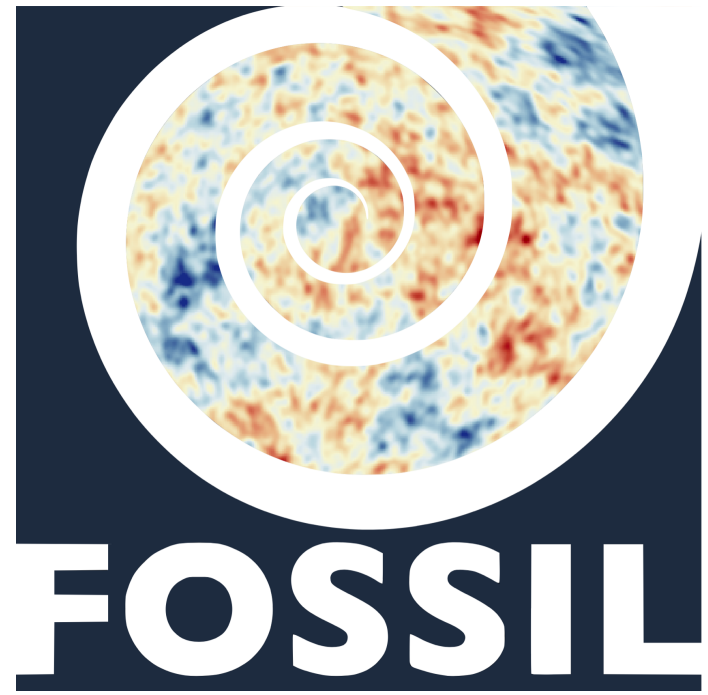

Concept evolution:

Balloon & gondola constraints



Instrumental concept:

- 5 days trans-Atlantic flight
- 90 GHz – 1.5 THz band
- $\Delta\nu = 15$ GHz
- ~3 deg eq. Gaussian beam
- 30 cm primary aperture

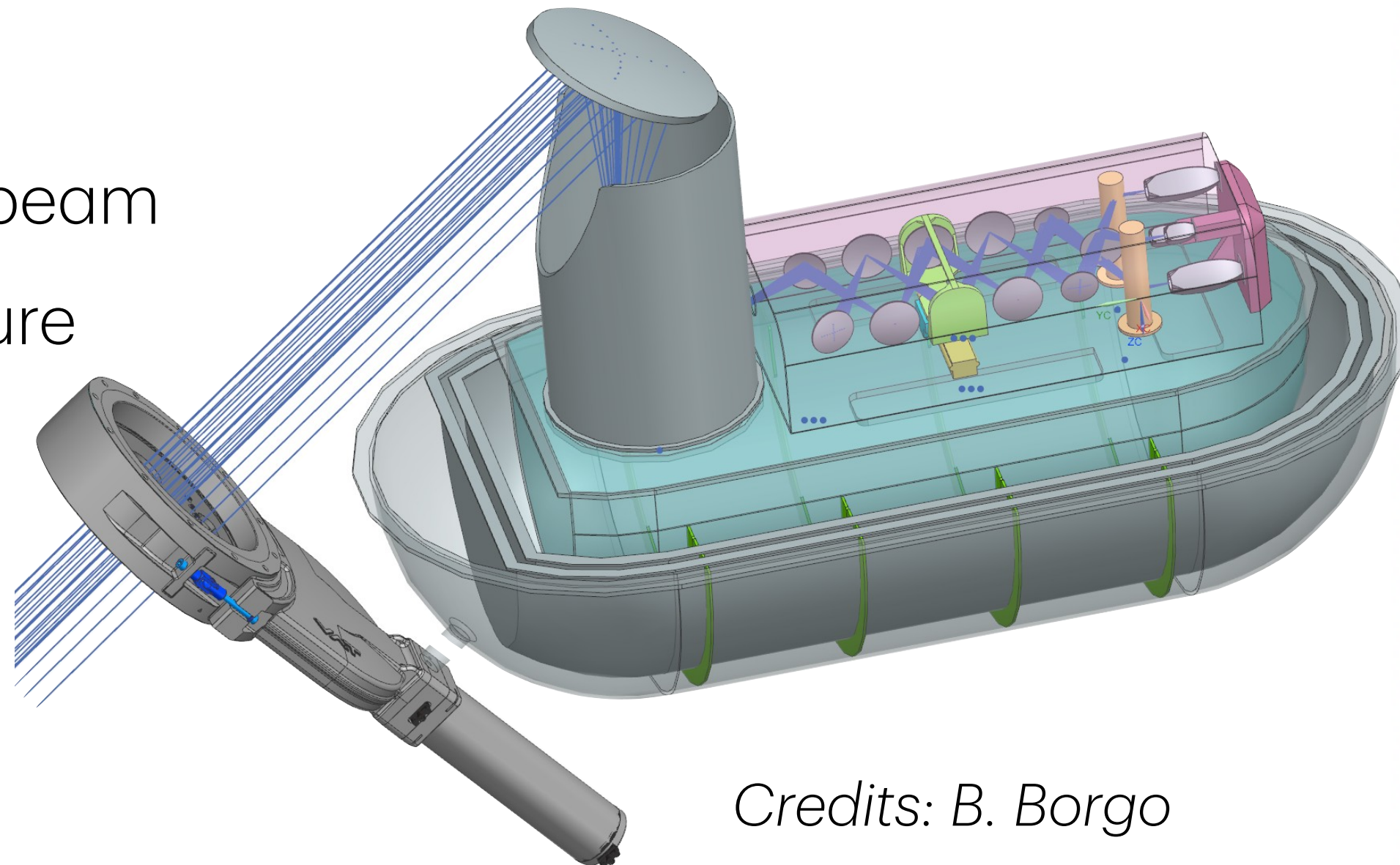

Credits: B. Borgo

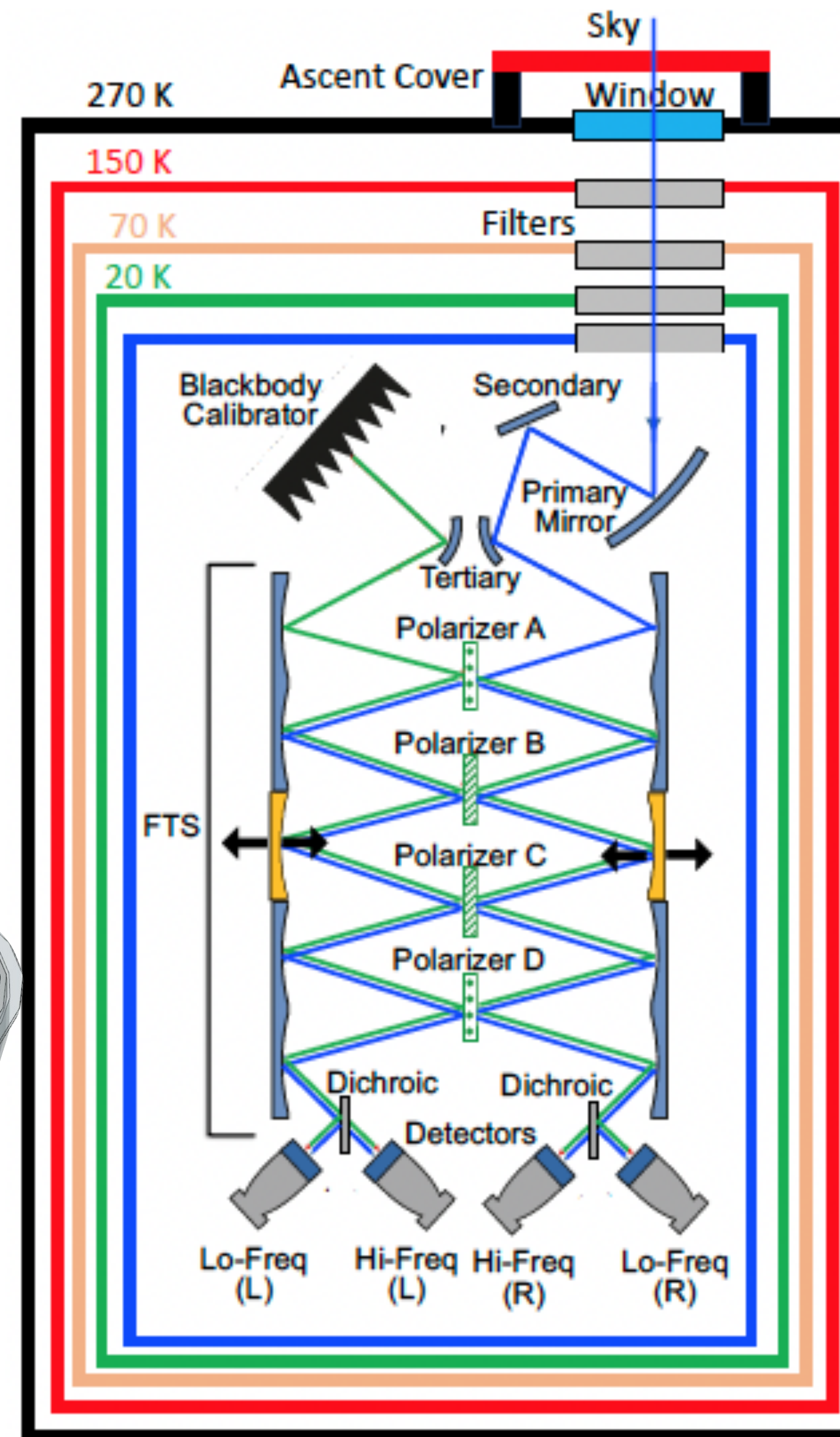

Residual atmosphere

Warmer components

Optics asymmetry

More compact FTS

Smaller frequency coverage

FOSSIL & BISOU forecasts

Sky model

Sky parameters: θ_i

I_ν : sky signal +
internal emissions

Instrument model

Instrumental noise
covariance matrix: $C_{\nu\nu'}$

Fisher Matrix:

$$F_{ij} = \sum_{\nu, \nu'} \frac{\partial I_\nu}{\partial \theta_i} C_{\nu\nu'}^{-1} \frac{\partial I_{\nu'}}{\partial \theta_j}$$

Forecasts

- **Signal Noise Ratio (SNR)**
on all sky parameters θ_i

Sky model - CMB spectral distortions

$$I_\nu^{\text{CMB}} = B_\nu(T_0) + \Delta I_\nu^{\text{CMB}} = B_\nu(T_0) + \underbrace{\Delta B_\nu}_{\text{orange}} + \underbrace{\Delta I_\nu^y}_{\text{blue}} + \underbrace{\Delta I_\nu^{\text{rel}-y}}_{\text{purple}} + \underbrace{\Delta I_\nu^\mu}_{\text{green}} + \dots$$

Chluba & Jeong 2014

CMB spectral distortions

$= B_\nu(T_{\text{CMB}}) - B_\nu(T_0)$ with $B_\nu(T)$: blackbody emission at T

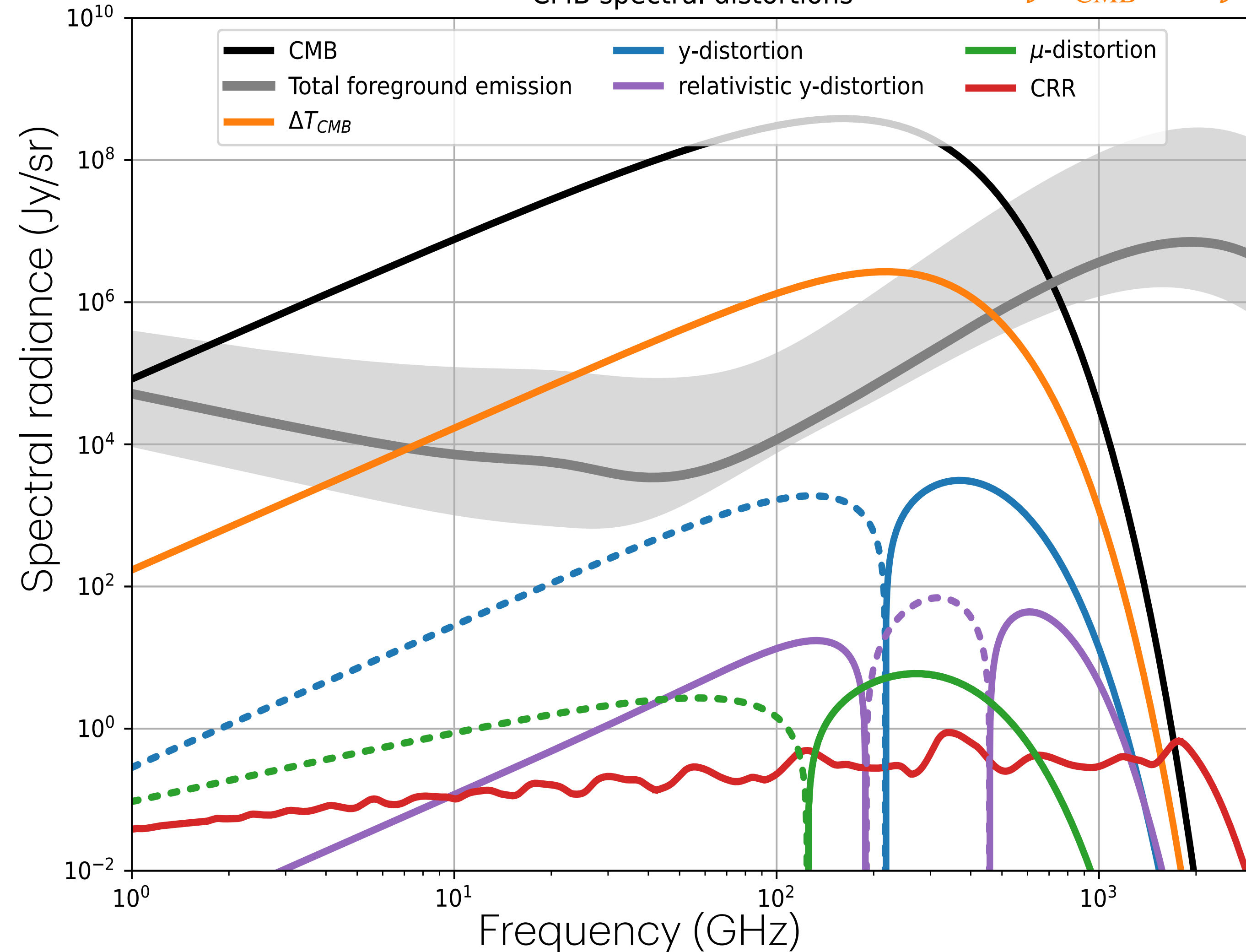

Moment expansion:

CMB	Parameters
Temperature shift	ΔT_{CMB}
y -distortion	y
Relativistic correction	T_e
μ -distortion	μ

Chluba+2014,
Abitbol+2017,
Hill+2015,
Chluba+2016,
Chluba+2017

- $\Delta I_\nu^y / \Delta I_\nu^{\text{CMB}} \simeq 10^{-6}$
- $\Delta I_\nu^{\text{rel}-y} / \Delta I_\nu^{\text{CMB}} \simeq 10^{-7}$
- $\Delta I_\nu^\mu / \Delta I_\nu^{\text{CMB}} \simeq 10^{-8}$

Sky model - Foregrounds

Foregrounds	Model	Parameters
Galactic dust	Modified blackbody	A_d, T_d, β_d
Synchrotron	Power law	A_s, β_s, C_s
Free-free	Power law	$A_{ff}, \beta_{ff}, C_{ff}$
AME	Power law	$A_1^{ame}, \nu_1, A_2^{ame}$
CIB	Modified blackbody	$A_{cib}, T_{cib}, \beta_{cib}$
Extragalactic CO lines	Template (Mashian+2016)	A_{CO}
Zodiacal dust	Modified blackbody	$\epsilon_{th}(\nu), T_{th}, \beta_{th}$
Zodiacal scattering	Modified blackbody	$\epsilon_{sc}, T_{sc}, \beta_{sc}$

Spatially varying (PySM)

Spatially uniform

only in $\pm 20^\circ$ from ecliptic

Towards more realistic sky model:

- Spatially varying foreground** emissions (through PySM)

Thorne+2017, Zonca+2021

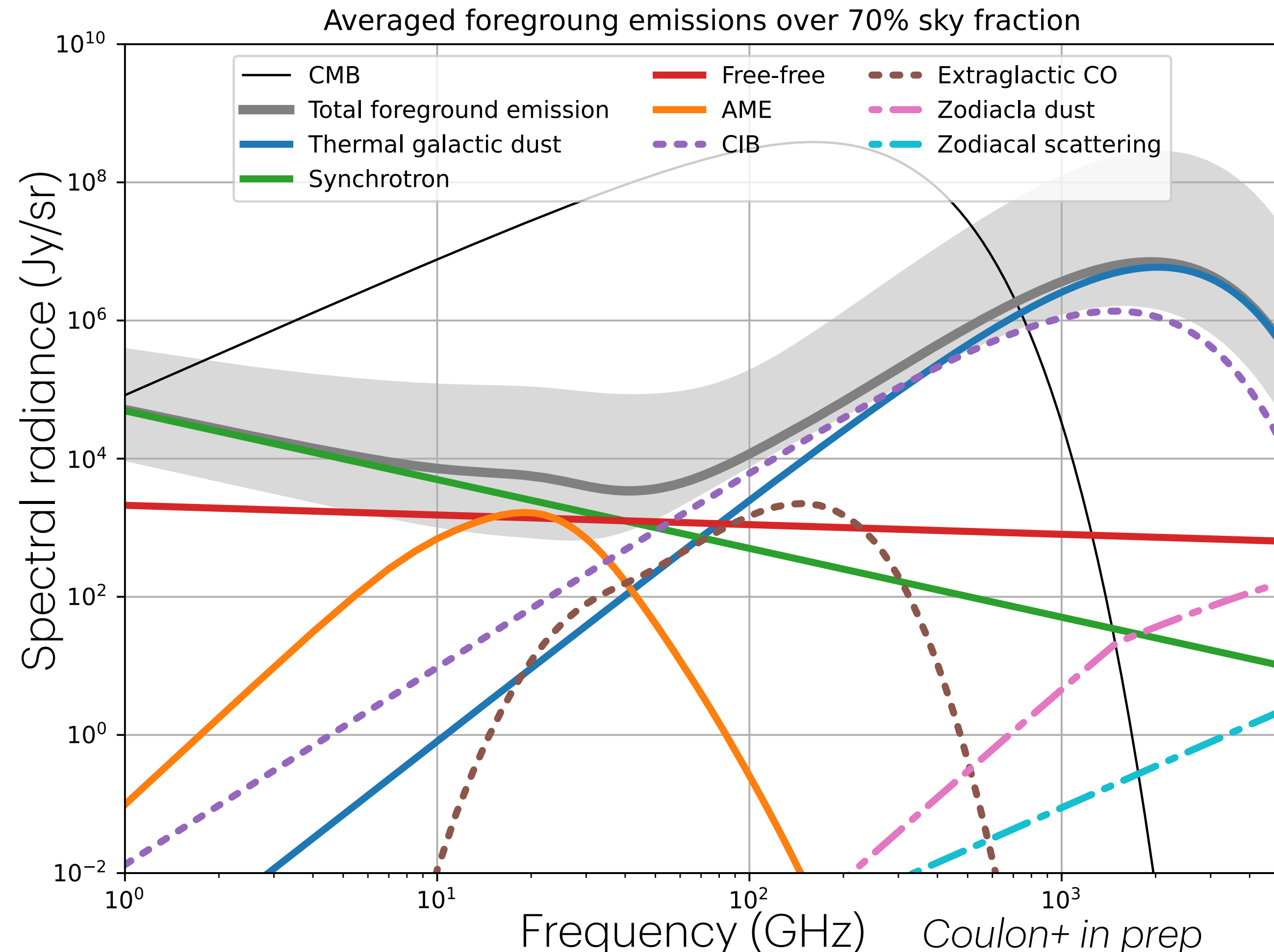

Instrument model

Parametric spectro-photometric model

- based on key sub-system

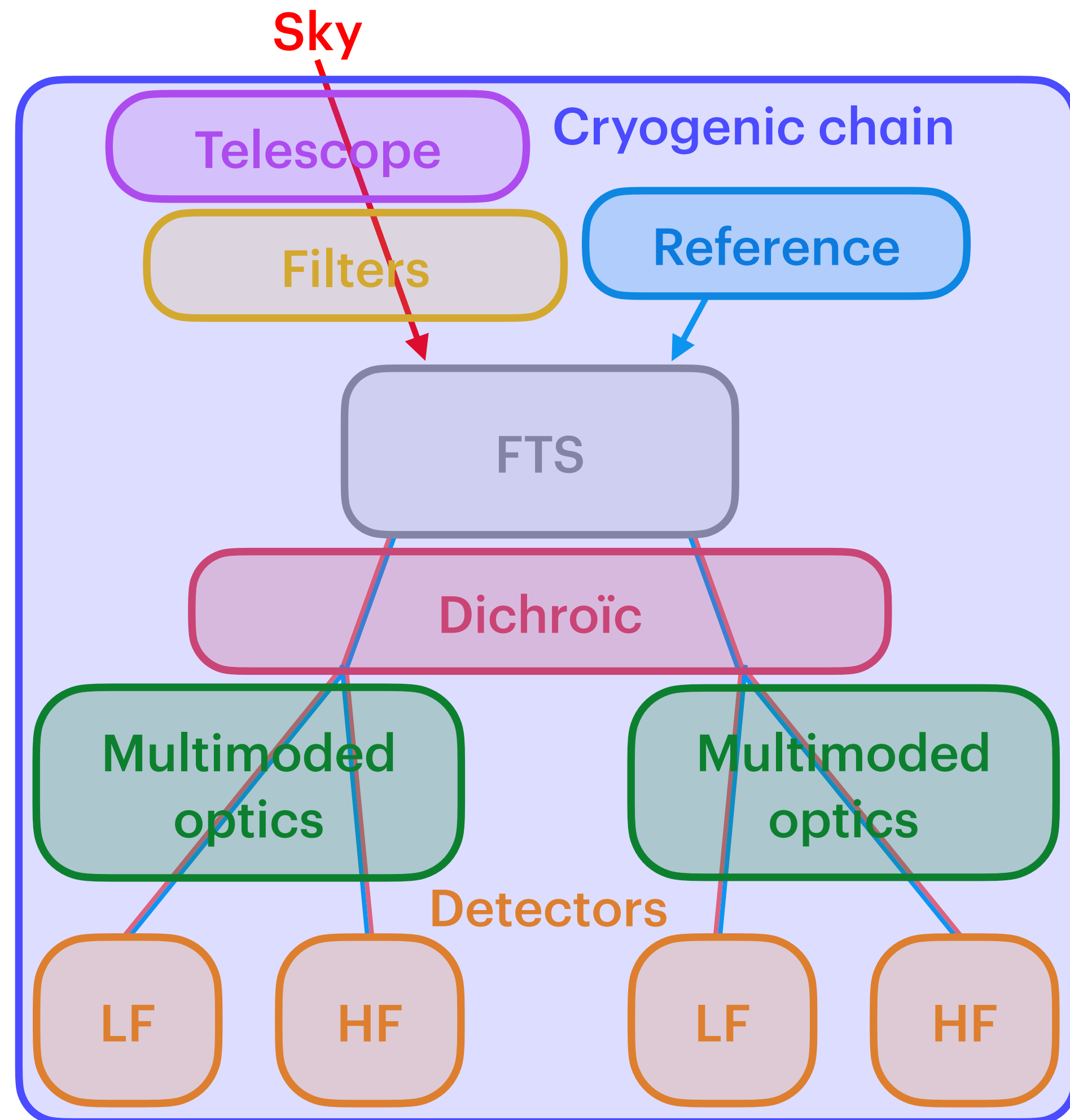

Instrument

Instrument and mission parameterisation		Notation
Spectral bin		$\Delta\nu$
Detectors efficiency		η
Number of detectors per FPU		N_{det}
Split frequency		ν_{split}
Number of modes		N
Primary mirror diameter		A
Minimal frequency		ν_{min}
Maximal frequency		ν_{max}
Temperature and emissivity of optics		$(\epsilon_k(\nu), T_k)_{1 \leq k \leq K}$
Effective integration time		τ
Line of sight		\vec{p}

Coulon+ in prep

Fisher forecasts & Optimisation

Instrument and mission concept optimisation

Sky model

Sky parameters: θ_i

I_ν : sky signal +
internal emissions

Fisher Matrix:

$$F_{ij} = \sum_{\nu, \nu'} \frac{\partial I_\nu}{\partial \theta_i} C_{\nu\nu'}^{-1} \frac{\partial I_{\nu'}}{\partial \theta_j}$$

Forecasts

- **Signal Noise Ratio (SNR)**
on all sky parameters θ_i

Instrument model

Instrumental noise
covariance matrix: $C_{\nu\nu}$

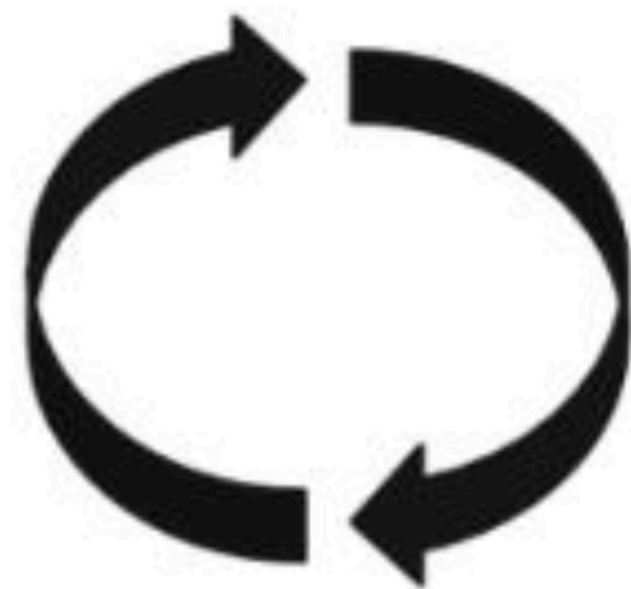

A new observational window

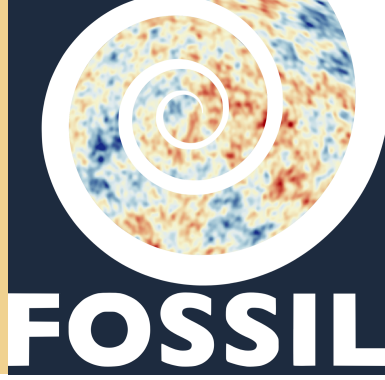
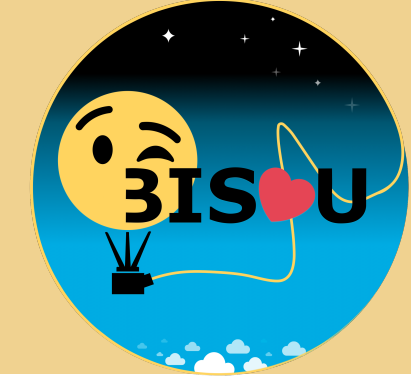

35+ years after FIRAS:

A full-sky absolute spectrometric survey

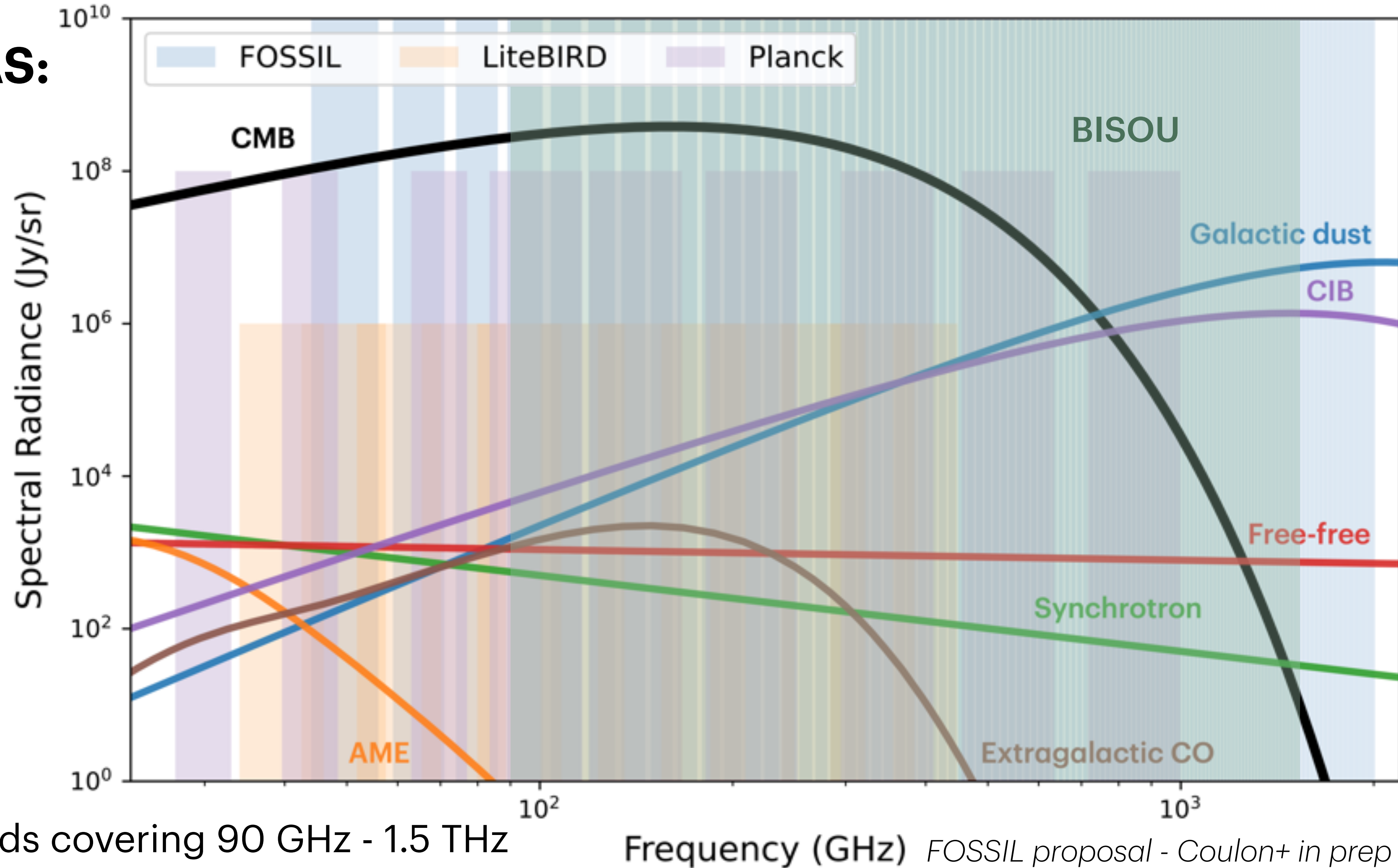

BISOU: ~90 frequency bands covering 90 GHz - 1.5 THz

FOSSIL: ~130 frequency bands covering 50 GHz - 2 THz

FOSSIL proposal - Coulon+ in prep

BISOU & FOSSIL



BISOU will:

- Measure **y monopole distortion** for the first time ever
- Measure T_{CMB} for the first since COBE/FIRAS in 90s
- Measure **CIB monopole** amplitude & Dust properties at unprecedented accuracy
- Improve by factor ~ 6 the **μ distortion** upper limits

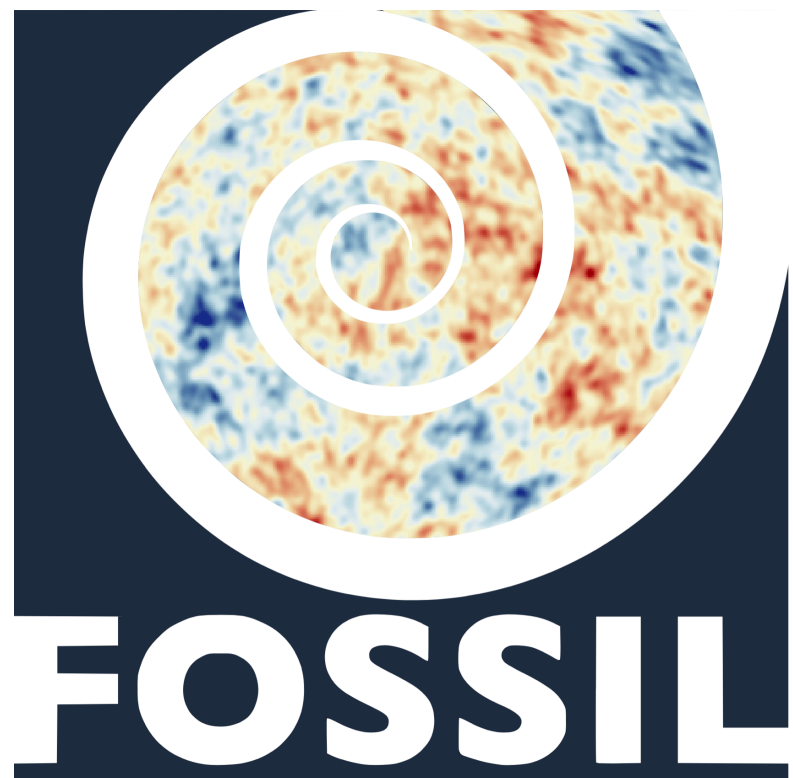

FOSSIL will:

- Bring a factor ~ 1000 improvement w.r.t. FIRAS
- Allow spectral distortion detection & probe the thermal history of the Universe
- Synergied with galaxy surveys, 21cm surveys, CMB imagers, etc.
- Build on european excellence
- Consolidate european scientific and technical expertise in CMB and cosmology

Conclusion

CNES:

- One of the top priorities together with CMB polarisation
- Prospectives 2019 and 2024

ASTRONET 2022 - 2035:

- Identifies spectral distortions as a new CMB probe

ESA Voyage 2050:

- New physical probes of the early Universe and high precision spectroscopy of CMB is one of the 3 themes for large missions (horizon >2055!)

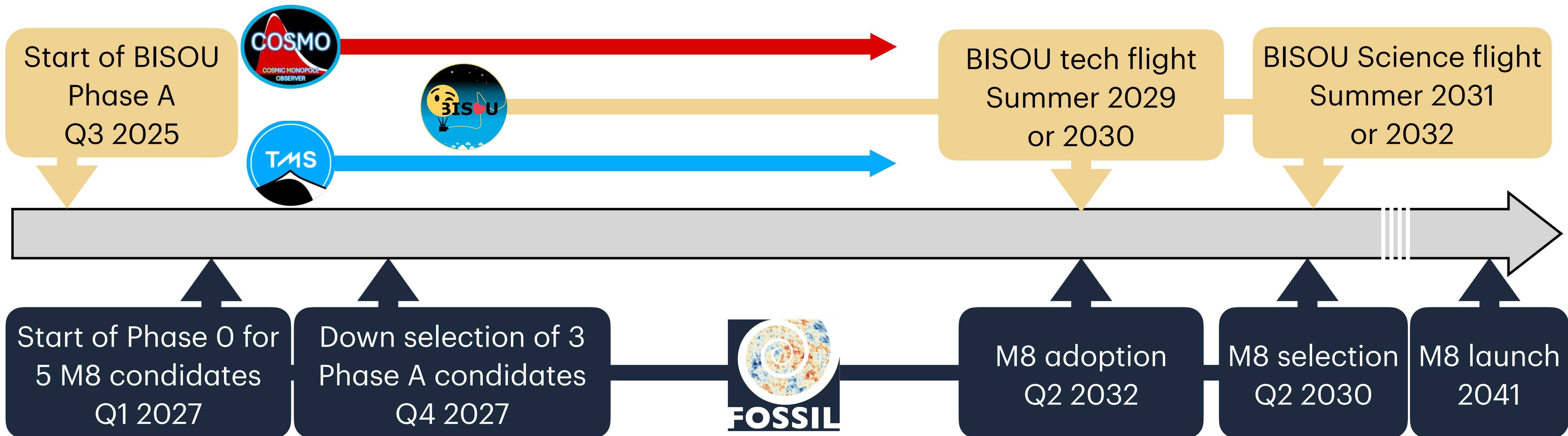

Conclusion

CMB spectral distortions is unique probe to understand the history of our Universe

It is scientifically timely and we are ready for it !

