

# Dark matter axion search with



**CNRS/IN2P3/IJCLab Université Paris-Saclay**

Akira Miyazaki, Yoann Kermaidic, Thibaut Houdy on behalf of MADMAX collaboration

# Axions: a byproduct to cancel the strong CP

Quantum Chromodynamics includes

$$L_{QCD} \supset -\frac{1}{4} G_{\mu\nu}^a G^{\mu\nu a} + \frac{g_s^2}{32\pi^2} \theta G_{\mu\nu}^a \tilde{G}^{\mu\nu a}$$

This term generates electric dipole moment in neutron

- Theory:  $d_n \sim (2.4 \pm 1.0) \times 10^{-3} \theta$  efm
  - Experiment:  $|d_n| < 1.8 \times 10^{-13}$  efm
- SciPost Phys. Lect. Notes 45 (2022)

$$\rightarrow |\theta| < 0.8 \times 10^{-10} \ll 1$$

***Naturalness problem without anthropic solution***

Introduce a new global chiral U(1) (PQ symmetry) field  $a$

$$\frac{g_s^2}{32\pi^2} \left( \theta + \frac{a}{F_a} \right) G_{\mu\nu}^a \tilde{G}^{\mu\nu a} \rightarrow 0 \text{ (after SSB)}$$

Spontaneous Symmetry Breaking

→ A Nambu-Goldston boson appears as a byproduct = **axion**

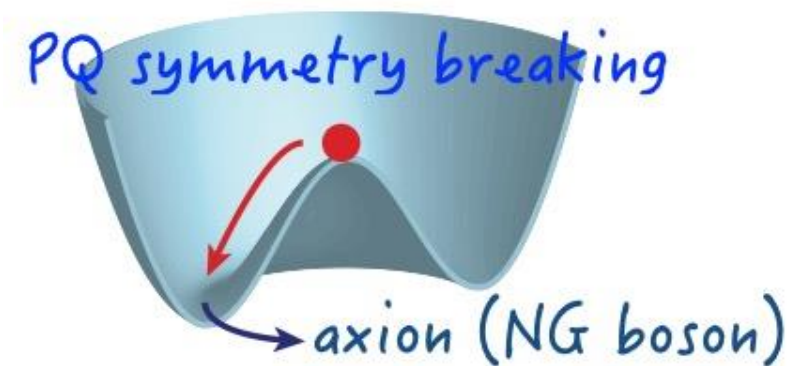

# Axion after QCD phase transition

PQ Symmetry is explicitly broken

→ Axion gains (light) mass

F. Chadha-Day, J. Ellis, D. J. E. Marsh, "Axion Dark Matter: What is it and Why Now?" arXiv:2105.01406

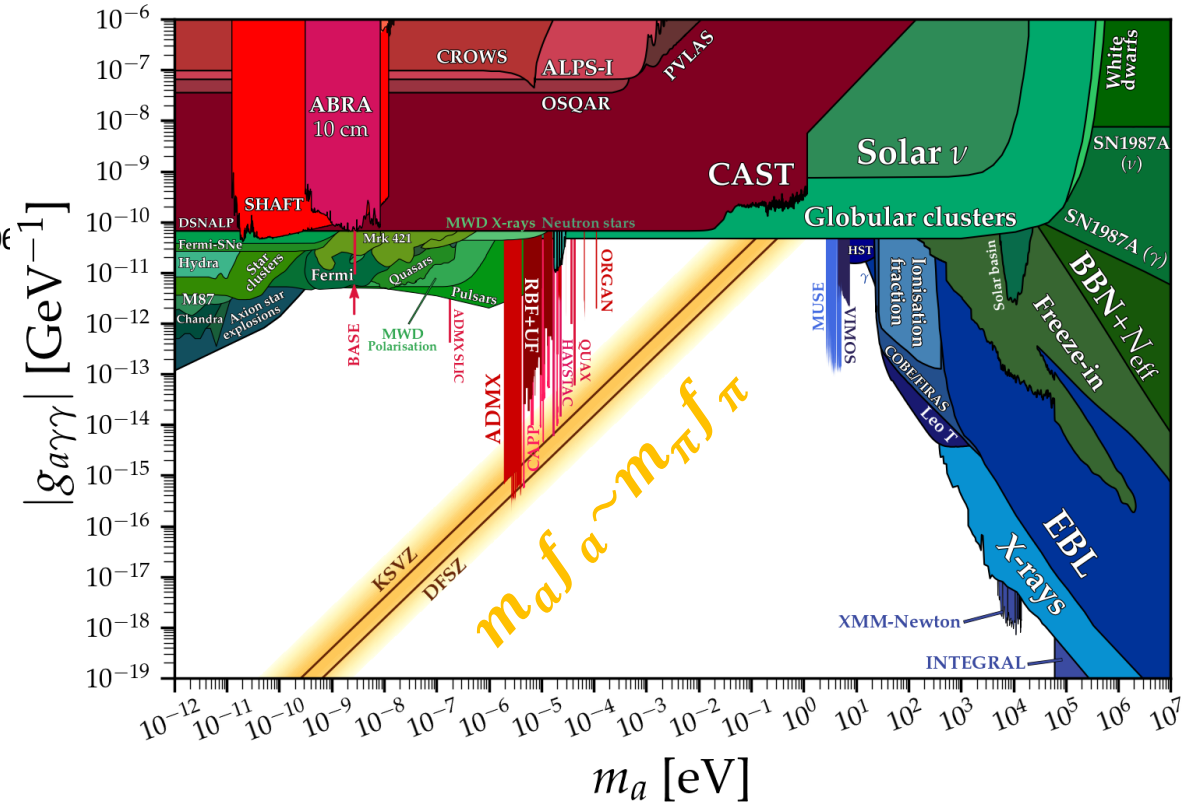
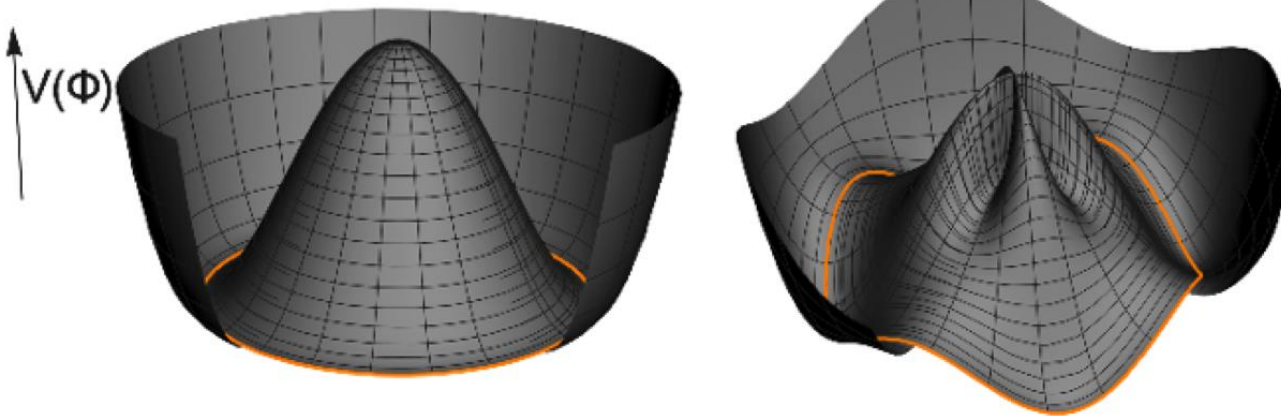

Axions are mixed with pions

$$m_a f_a \sim m_\pi f_\pi$$

→ Coupling vs mass predictable!

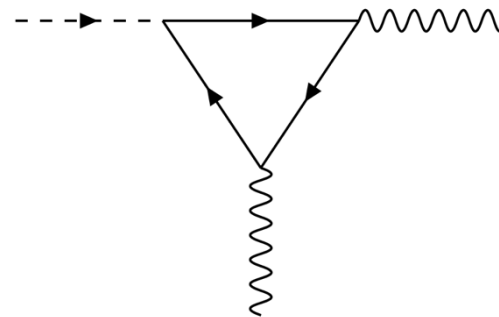

Axion couples to two photons (Primakoff effect)

→ **RF/microwaves** 3

# Axion as dark matter

Axion loses kinetic energy **non-thermally** by coherent oscillation in the PQ potential

Misalignment mechanism

$$\frac{d^2 a}{dt^2} + 3H(t) \frac{da}{dt} + m_a(T)^2 a = 0$$

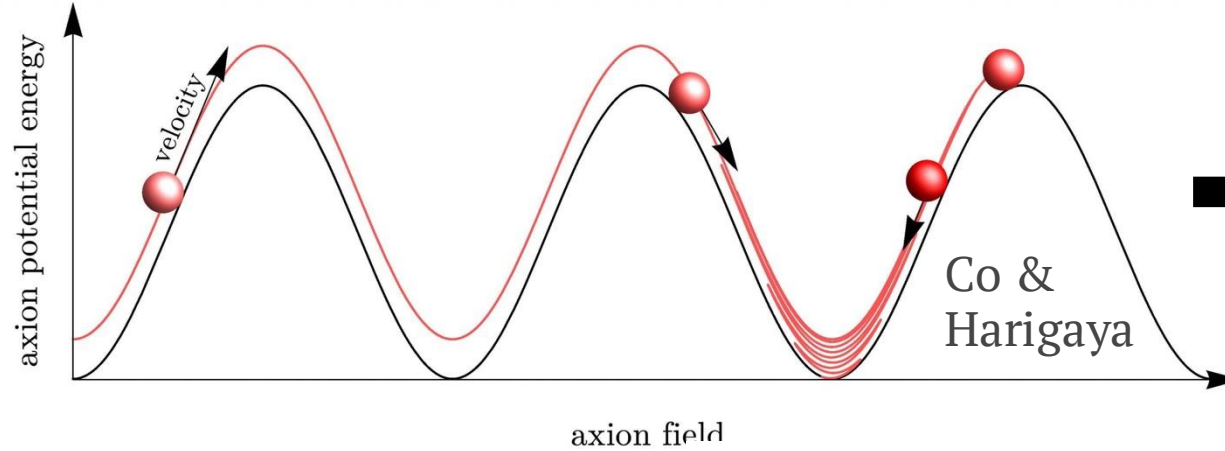

Two possible scenarios related to the energy scale of inflation

$\Lambda(\text{PQ}) > \Lambda(\text{inflation})$

$\Lambda(\text{PQ}) < \Lambda(\text{inflation})$

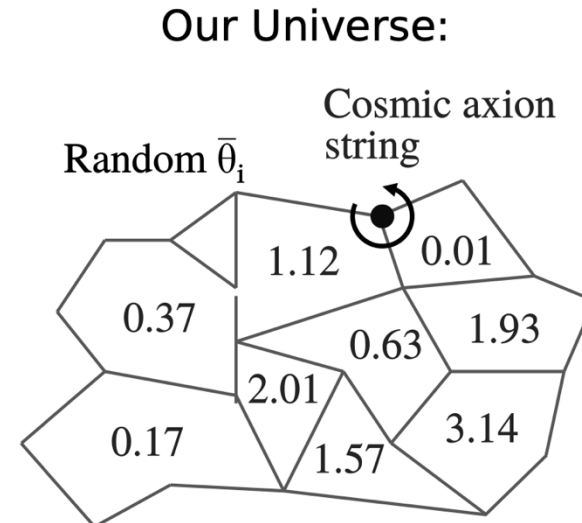
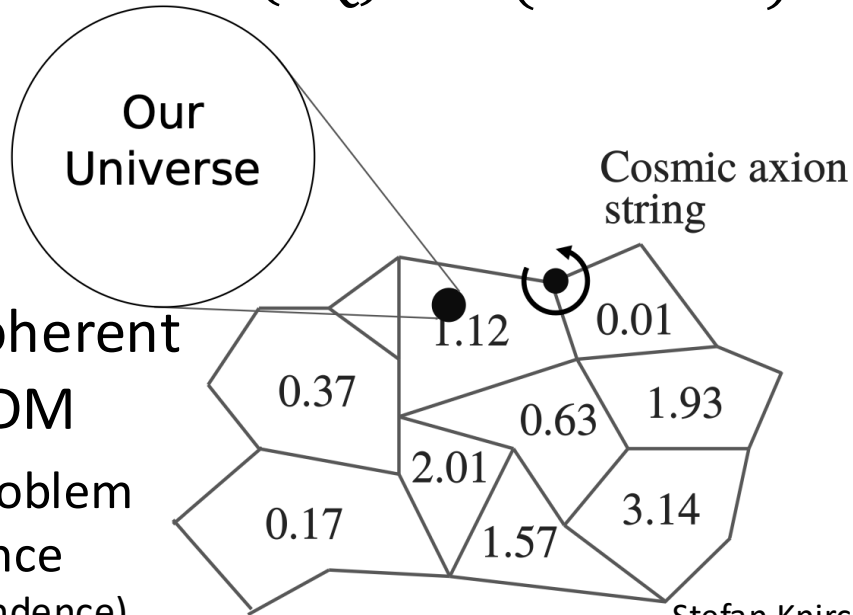

Annihilating axion string = DM

Natural solution to DM abundance

Remaining coherent oscillation = DM

Naturalness problem in DM abundance (initial value dependence)

Stefan Knirck PhD thesis



# Axions dark matter generates classical microwave under magnetic fields

$$\lambda_B \sim \frac{2\pi \times 196 \text{ MeVfm}}{0.07\% \times 80 \mu\text{eV}} \sim 22 \text{ m}$$

$$\bar{n} \sim \frac{0.4 \text{ GeV/cm}^3}{80 \mu\text{eV}} \sim 5 \times 10^{12} \text{ cm}^{-3}$$

$$\rightarrow E_{cl}^2 = \frac{\bar{n}}{\lambda} \gg \frac{1}{\lambda^4} \sim \langle 0 | \hat{E} \cdot \hat{E} | 0 \rangle = E_q^2$$

- Highly degenerate condensate
- Quantum fluctuation negligible  
→ Classical fields

Axions enter Maxwell equations

$$\begin{cases} \nabla \cdot \mathbf{E} = \rho - g_{a\gamma\gamma} \mathbf{B} \cdot \nabla a \\ \nabla \cdot \mathbf{B} = 0 \\ \nabla \times \mathbf{E} = -\frac{\partial \mathbf{B}}{\partial t} \\ \nabla \times \mathbf{B} = -\frac{\partial \mathbf{E}}{\partial t} + \mathbf{J} - g_{a\gamma\gamma} \left( \mathbf{E} \times \nabla a - \frac{\partial a}{\partial t} \mathbf{B} \right) \end{cases}$$

*Effective charge & current*

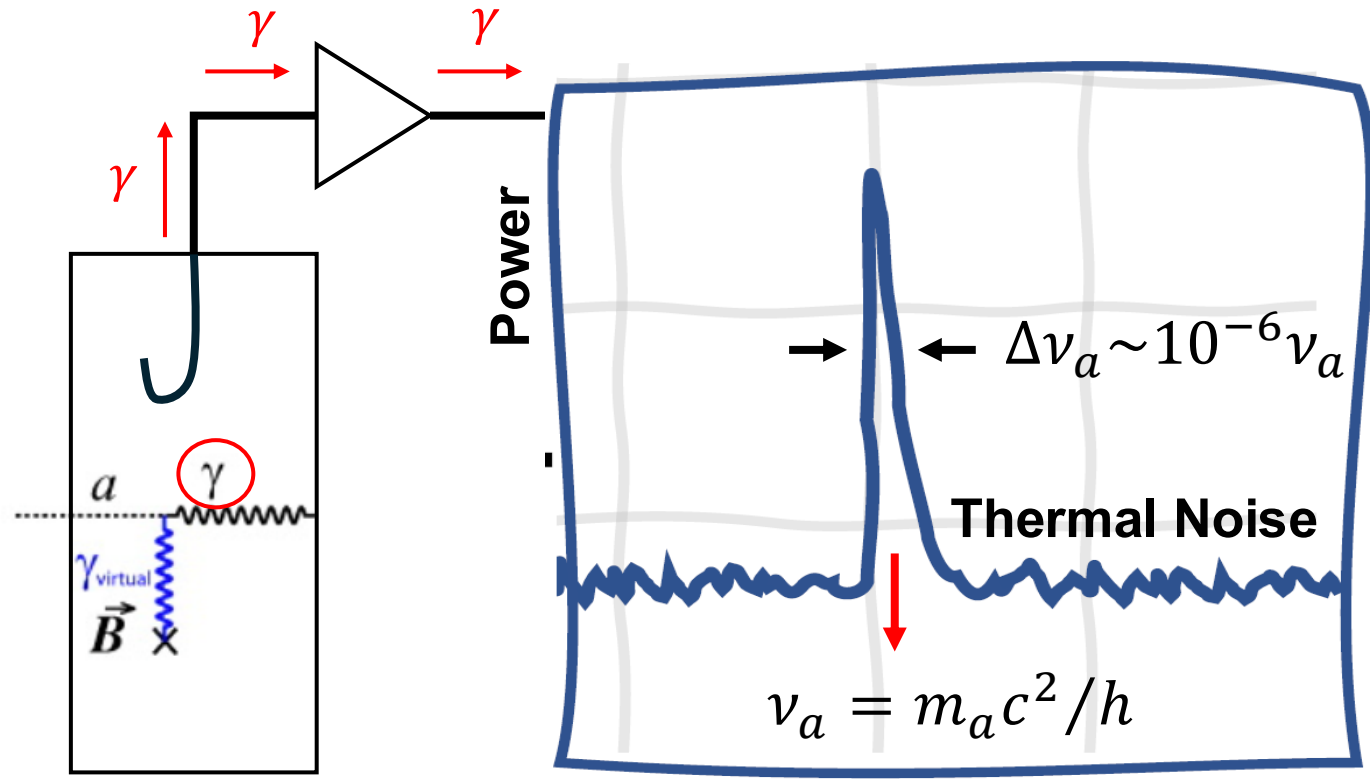

$m_a = 80 \mu\text{eV}$  generates narrowband 20 GHz MW under a static magnetic field **Frequency**



# Challenge to address 80 $\mu\text{eV}$ ~ 20 GHz ~ 1.5 cm

$m_a > 40 \mu\text{eV}$  (10 GHz) is motivated (post-inflationary scenario, kinetic misalignment, etc) **but...**

**Mismatch in wavelength!**  $\rightarrow \lambda_\gamma = 1.5 \text{ cm} \ll \lambda_B = 22 \text{ m}$

$$P_S \propto \left(\frac{V}{136\text{L}}\right) \left(\frac{B}{6.8\text{T}}\right)^2 \left(\frac{C}{0.4}\right) \left(\frac{Q}{50000}\right)$$

Challenging to keep overlap  
integral  $C$  nonzero while keeping  
the detector size  $V$  large

Rev. Sci. Instrum.  
92 124502 (2021)

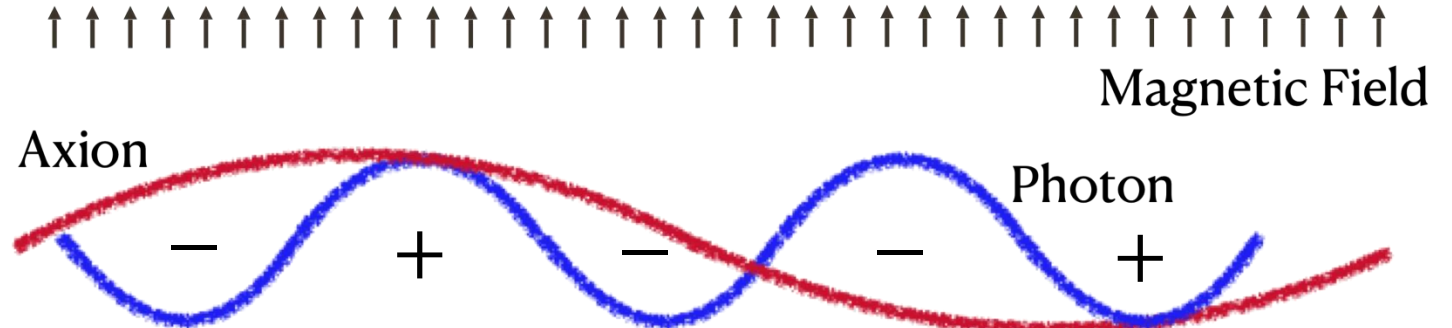

Courtesy of Alex Millar Jr.

$\rightarrow$  Insert dielectric disks to cancel  
the negative overlaps!

$$P_S \propto \left(\frac{A}{1 \text{ m}^2}\right) \left(\frac{B}{10 \text{ T}}\right)^2 \left(\frac{\beta^2}{50000}\right)$$



Caldwell et al., PRL 118, 091801 (2017)

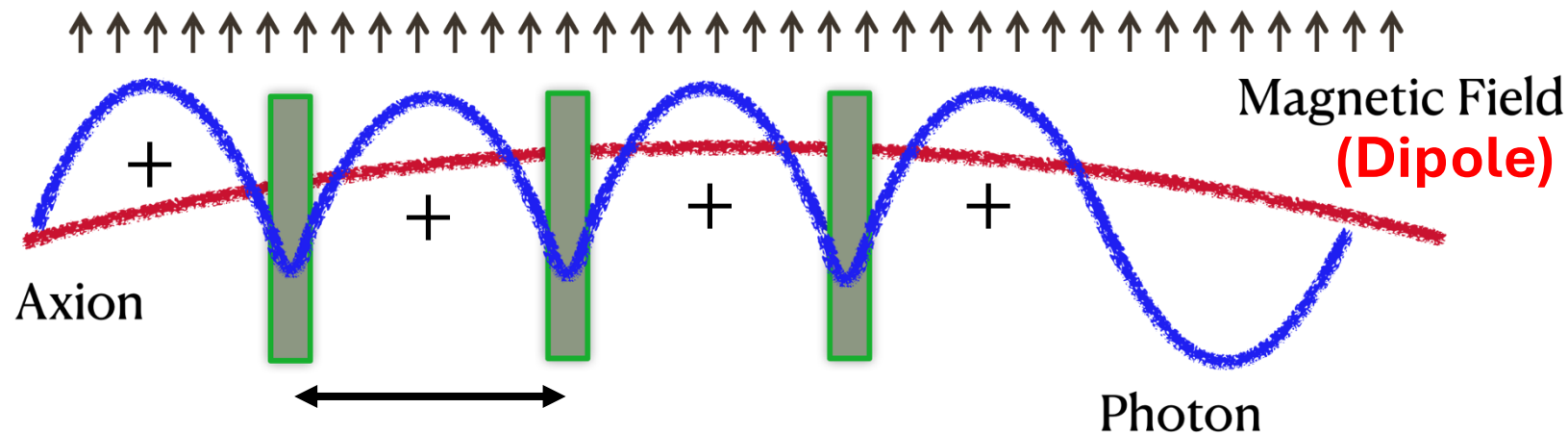



# Boost factor $\neq$ cavity quality factor (Q)

$$P_S \propto \left(\frac{V}{136L}\right) \left(\frac{B}{6.8T}\right)^2 \left(\frac{C}{0.4}\right) \left(\frac{Q}{50000}\right) \rightarrow P_S \propto \left(\frac{A}{1 \text{ m}^2}\right) \left(\frac{B}{10 \text{ T}}\right)^2 \left(\frac{\beta^2}{4000}\right)$$

<http://lossenderosstudio.com/glossary.php?index=q>

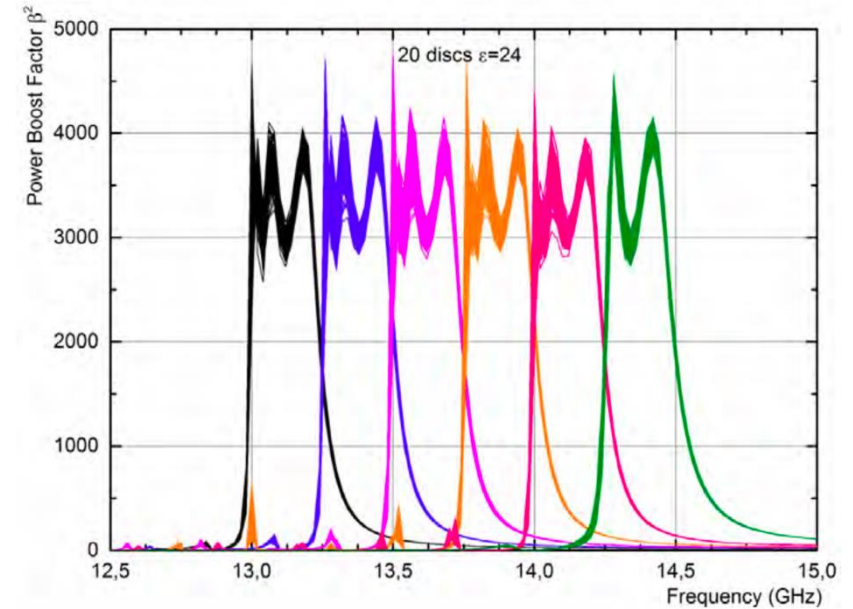
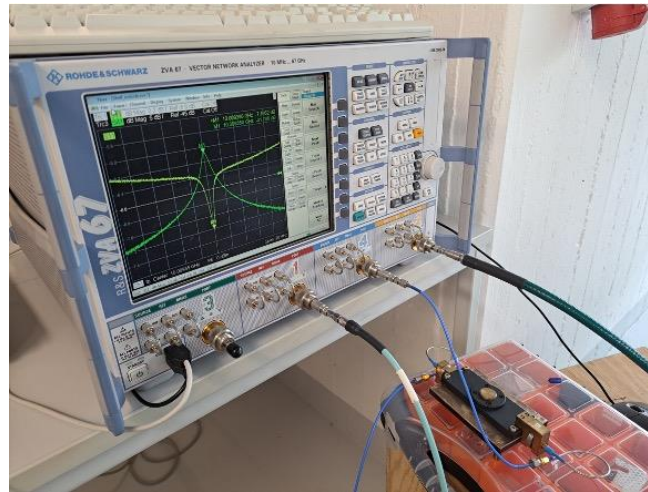
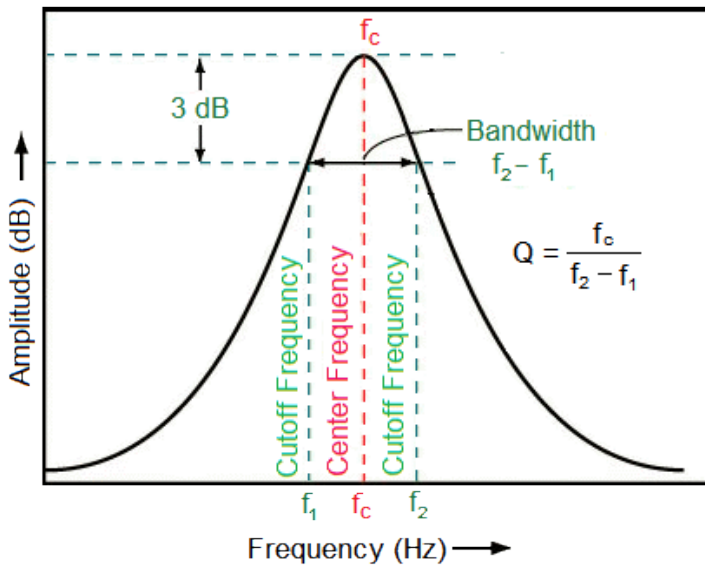

Cavity Q is  $f / \Delta f$  of external excitation  
 → Observable via Network Analyser

Boost factor is for axion-induced signals  
 → Virtual concept and not plug & play

→ Calibration & determination of  $\beta^2$  has been one of the challenges in MADMAX



# MADMAX collaboration



MAX-PLANCK-INSTITUT  
FÜR PHYSIK



Max-Planck-Institut  
für Radioastronomie



Universität Hamburg  
DER FORSCHUNG | DER LEHRE | DER BILDUNG

RWTHAACHEN  
UNIVERSITY



Universidad  
de Zaragoza

HARVARD  
UNIVERSITY



EBERHARD KARLS  
UNIVERSITÄT  
TÜBINGEN



Fermilab

Northeastern  
University





# MADMAX overview

Ellipsoidal mirror to focus MW

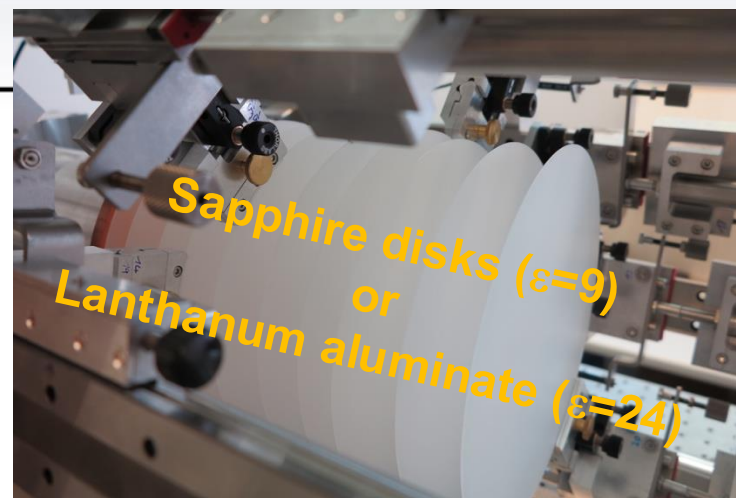
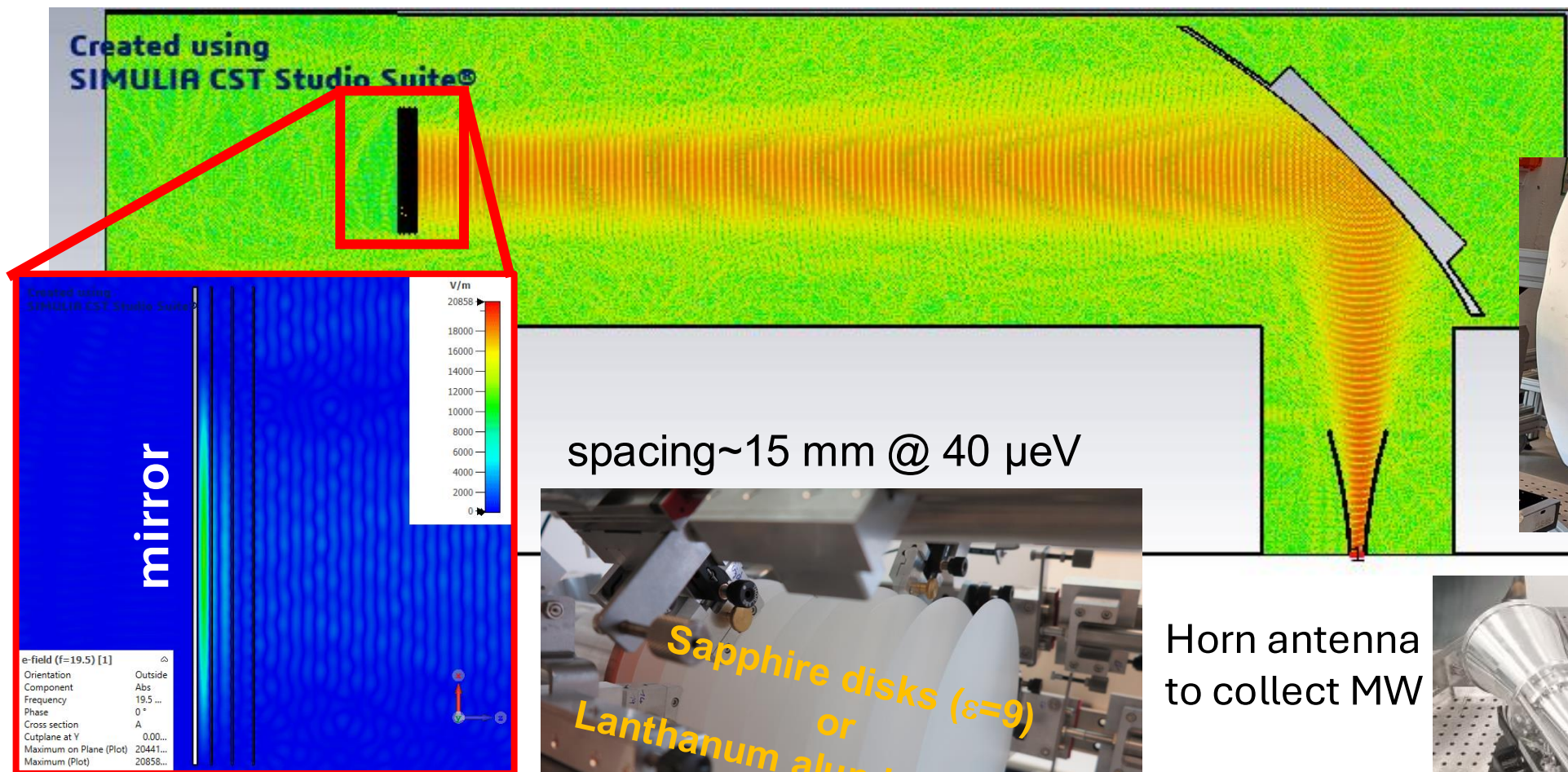

Horn antenna to collect MW

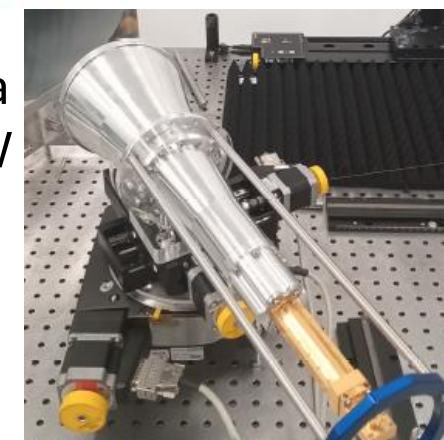

Resonance inside the dielectric disks



# Technical milestones

- ✓ Piezo worked at 5 K + 5.3 T
- ✓ Disk motion with piezo-motor was successfully tested at 4K or 1.6 T

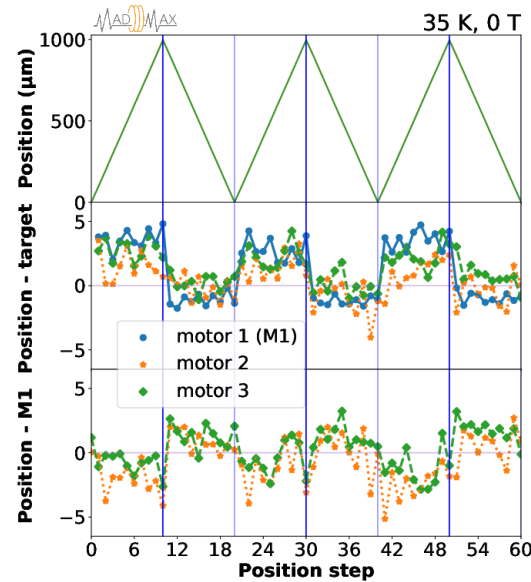
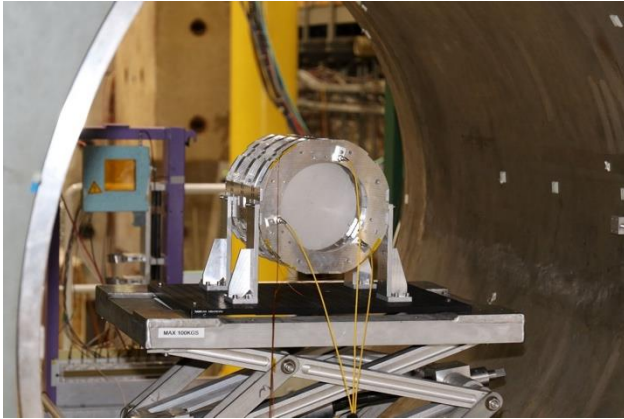
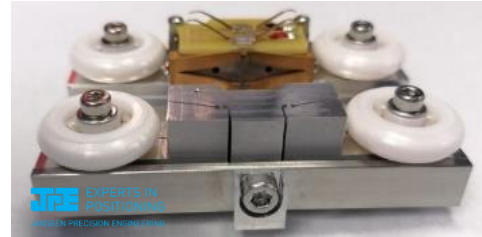

- ✓ Cable-in-Conduit Conductor
- ✓ MACQU Demo Coil
- ✓ Dipole feasible!
- Fabrication (\$\$\$)

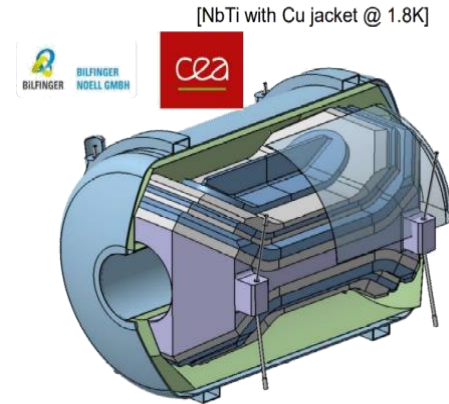
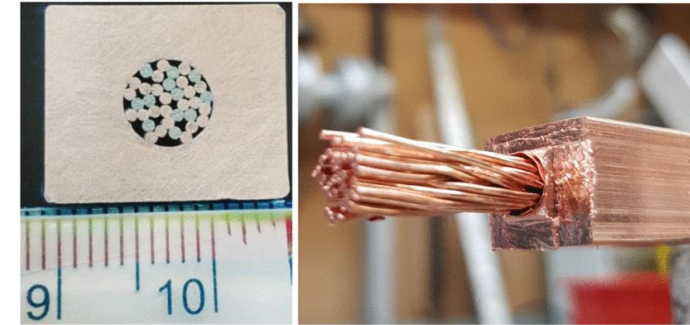

Lorin et al., IEEE TAS 33 (2023) 1

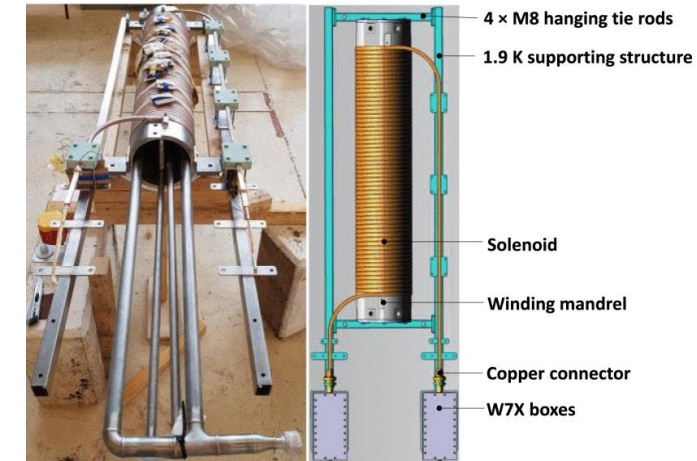

[MADMAX collaboration, 2024 JINST 19 T11002](#)

Boost factor  $\beta^2 \neq$  cavity Q  $\rightarrow$  before large scale experiments...small setups!

- ✓ Boost factor determination & first physics runs without piezo-tuning & existing dipole



# Close Booster prototype for axion(-like particle) search

Name	Booster	Disks	Test @CERN
CB200	Closed	3, <b>fixed</b> $\phi = 200$ mm	2024 (room temp., B-field)

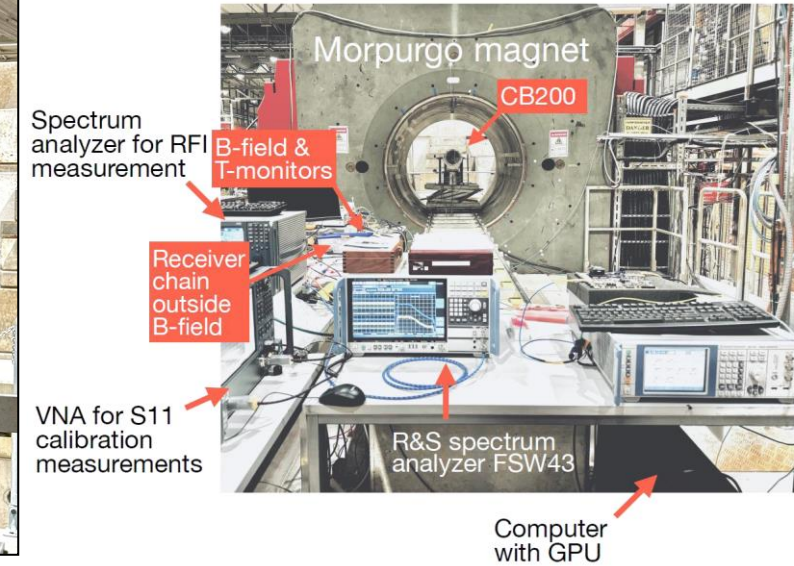
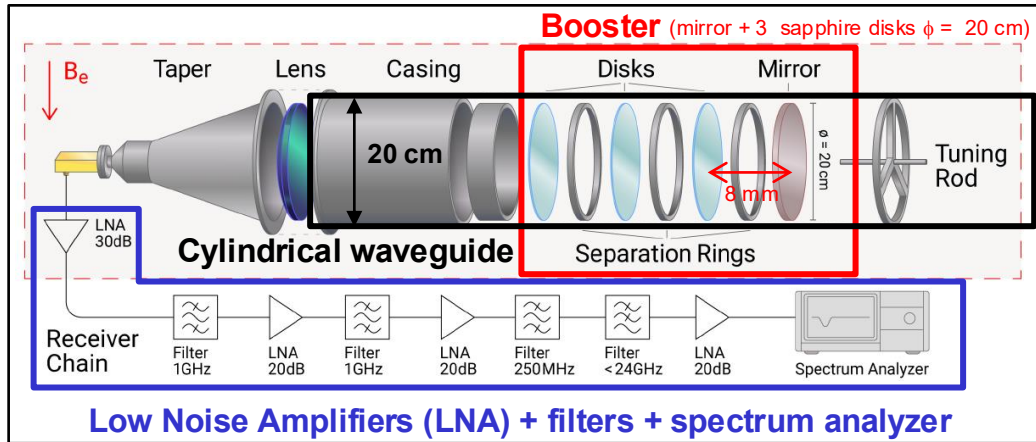

- Booster peak tuned at 2 frequencies  $\sim 18.5$  and  $19.2$  GHz
  - manual change of disk distances by  $\sim 0.3$  mm with separation rings
- $O(10$  MHz) variations around these frequencies
  - manual change of mirror-disk distance by  $O(10$   $\mu\text{m})$  with tuning rod
- 15 days of data in Morpurgo magnet at CERN
  - $B=1$  to  $1.6$  T

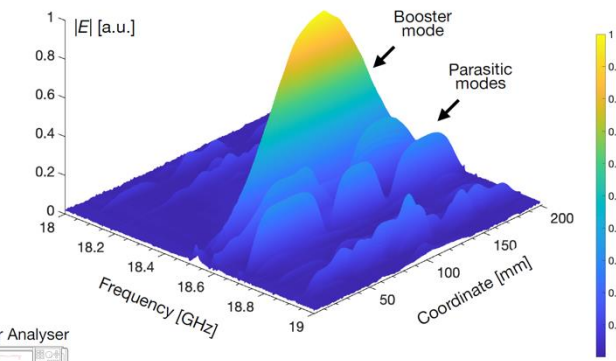
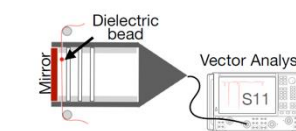

Why close cylinder setup  $\rightarrow$  waveguide resonant mode ( $\text{TE}_{11}$ ) are clear to model  $\beta^2$



# $\beta^2$ determination in close booster setup

## Model-based approach

Modelling the TE<sub>11</sub> booster with free parameters ( $\epsilon$ , thickness, spacing, mismatch, etc)

1) Fit to determine parameters

- MW measurement data
- Reflection data
  - Noise power resonance

2) Calculation with determined parameters

boost factor  $\beta^2$

- Monte-Carlo approach to propagate the errors in parameters
- Limitation of the modelling (3D effect, etc) well included in the uncertainty
- In-situ monitoring of the booster resonance during physics run via noise power

→  $\beta^2$  determined with ~15% errors

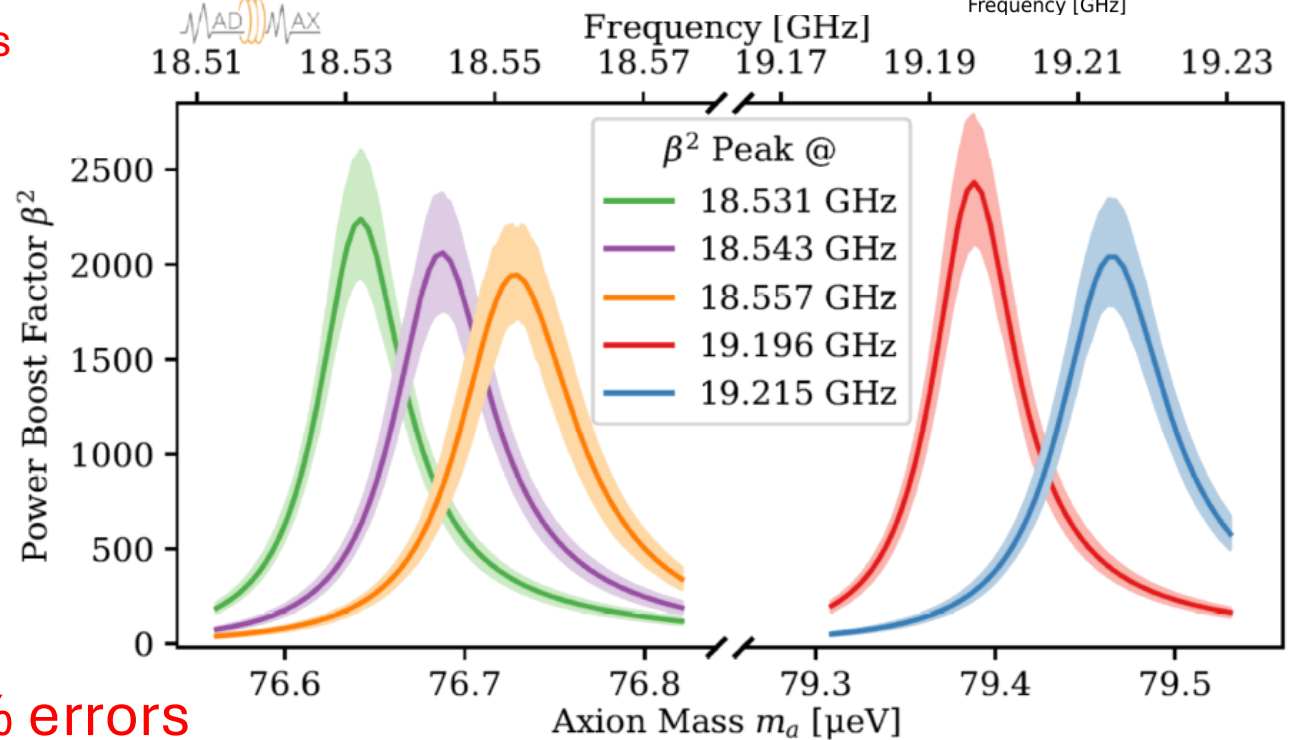
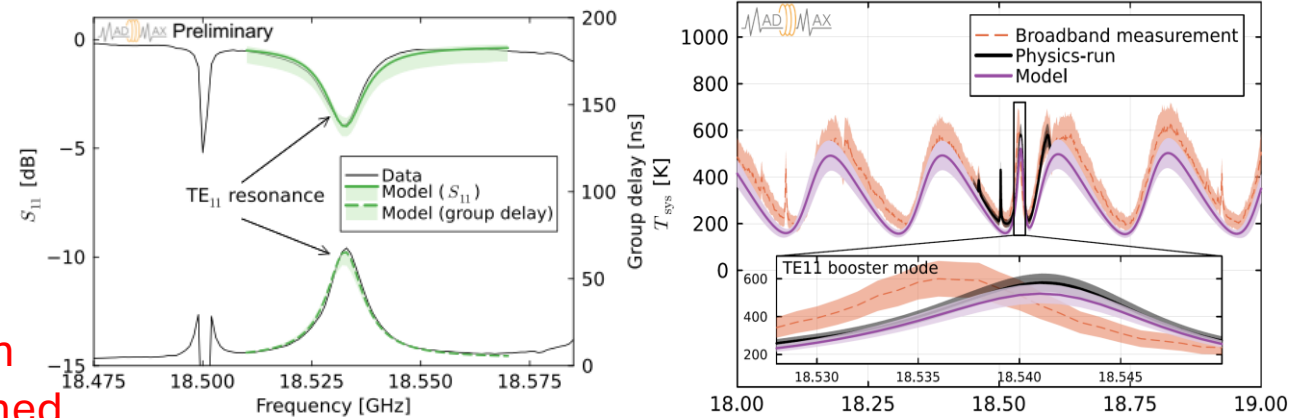



# First physics result of axions(-like particle) search

- No excess observed in acquired power spectra [HAYSTACK procedure PRD96 (2017) 1523008]
- Limits on axion-photon coupling  $|g_{a\gamma\gamma}|$  [for each 0.9 kHz bin]
- Limits better than existing ones by up to x3 with modest system [few small disks, reduced B field]  
→ Proving substantial potential of the MADMAX concept

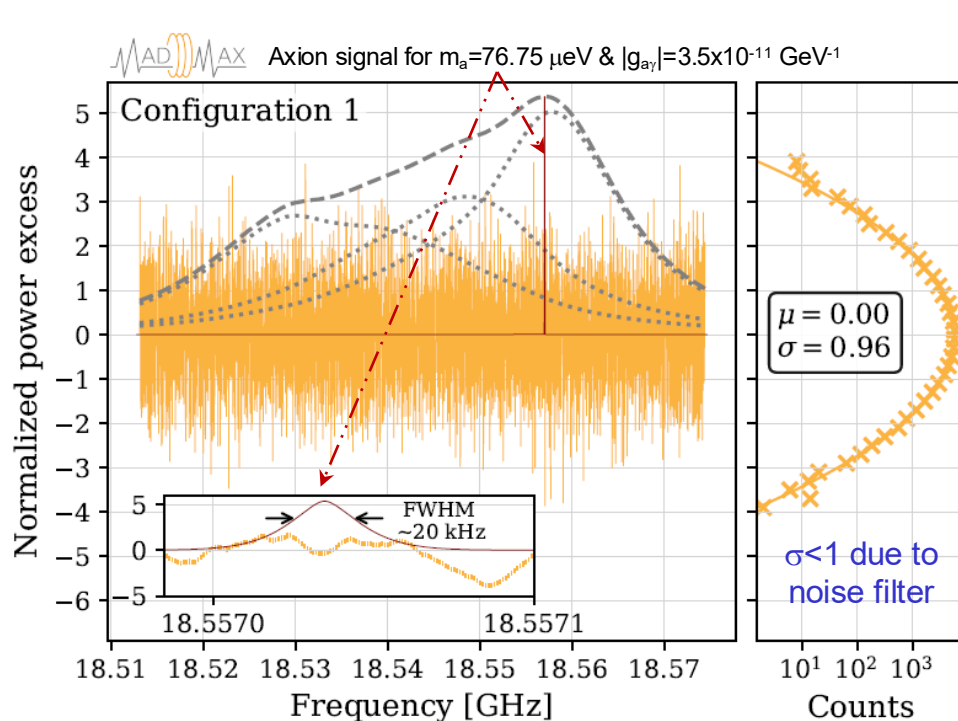

[MADMAX collaboration, PRL 135, 041001 \(2025\)](#)

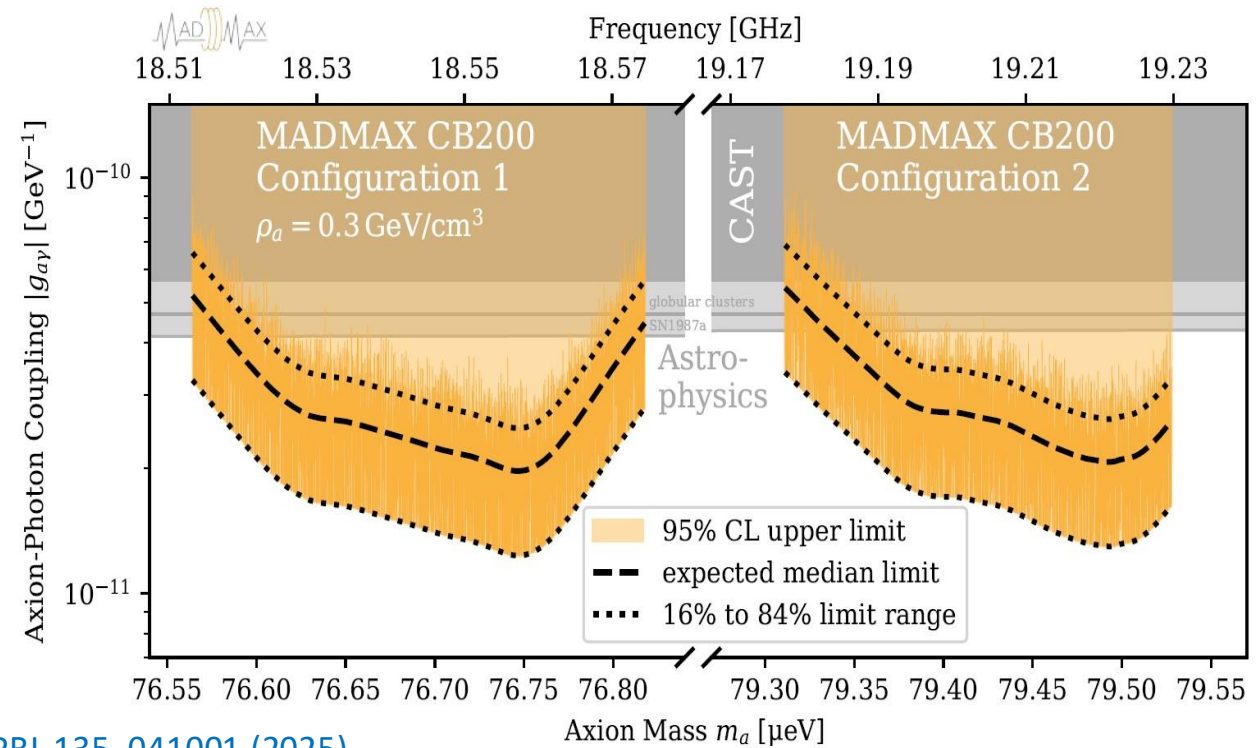

**First dark matter axion search with the dielectric haloscope!**



# Work in progress: cryogenic calibration & cryostat & dipole

- Small cryostat prototype at CERN

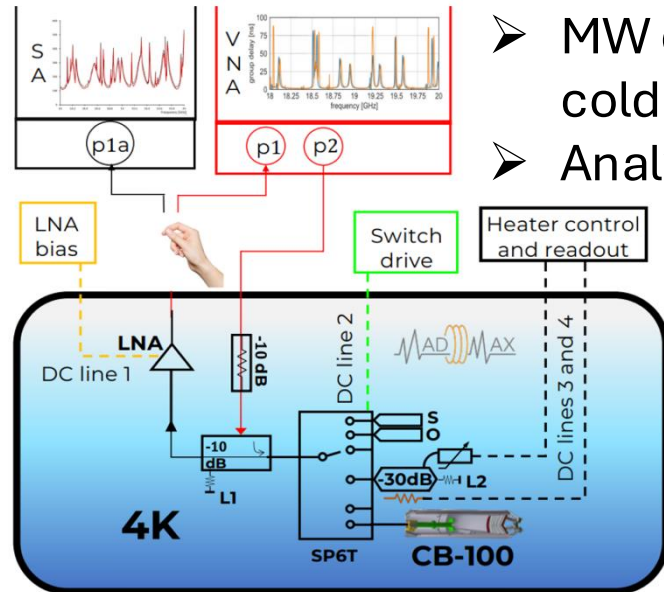
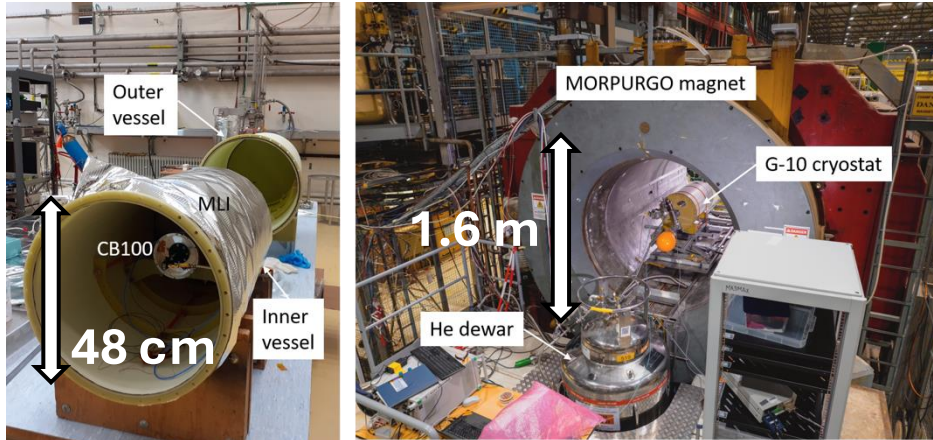

- MW calibration at cold is challenging
- Analysis on-going

D. Kreikemeyer et al. JINST 20 T02005 (2025)

- Large prototype cryostat & optics under commissioning

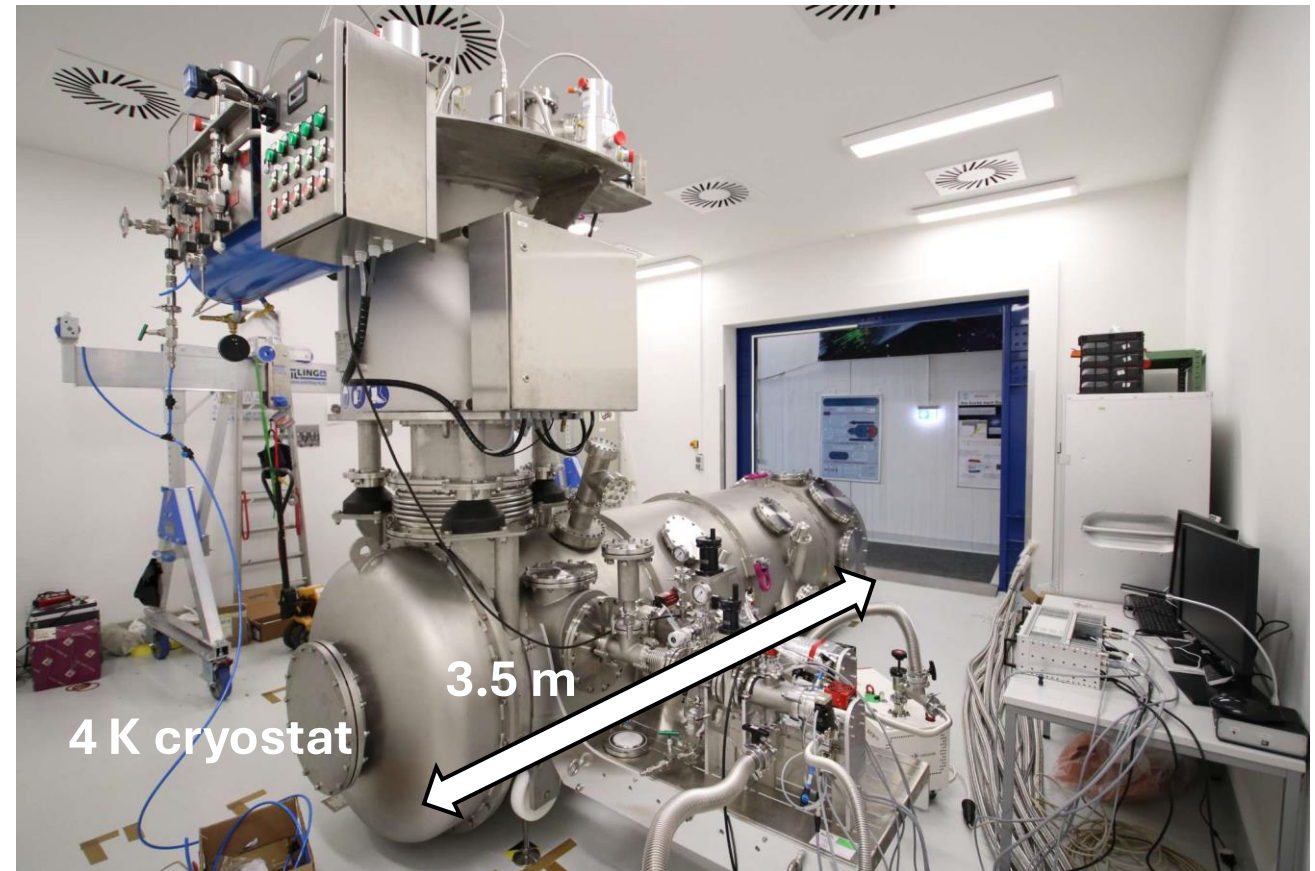

- Intermediate-scale custom-made dipole (60 cm, 4T) at DESY ~2031



# IJCLab's contributions to MADMAX 1: dielectric disks

$\Phi 300\text{mm}$   $t1\text{mm}$  sapphire is deformed

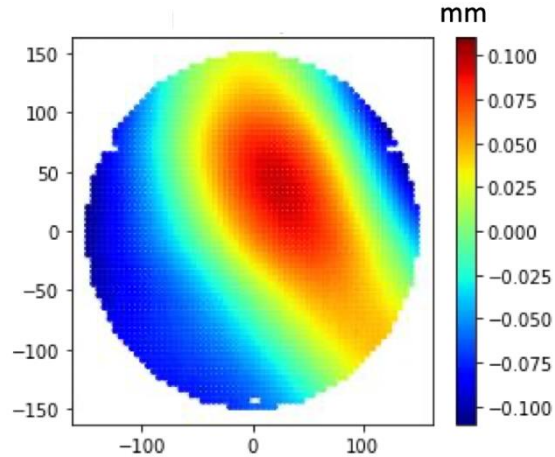
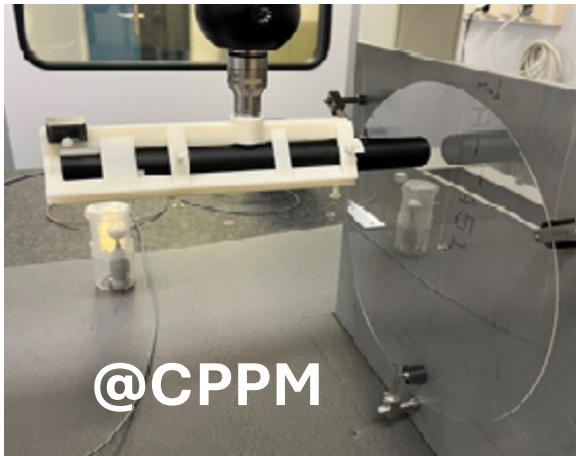

Impact: shift and uncertainty in  $\beta^2(\omega)$

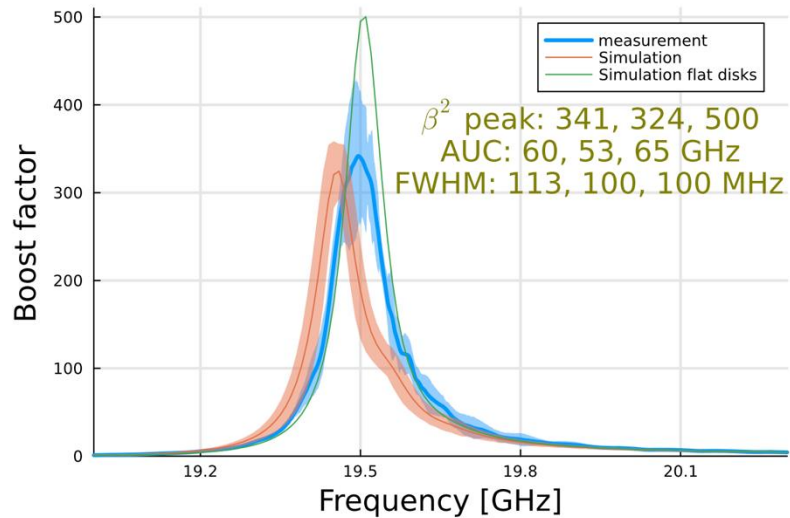

Two solutions proposed by IJCLab

$\Phi 300\text{mm}$   **$t1.5\text{mm}$**  sapphire with a new fabrication technique (KC3) by Kycera

→ deformation reduced by 1/10

(But more expensive  
☹...money...)

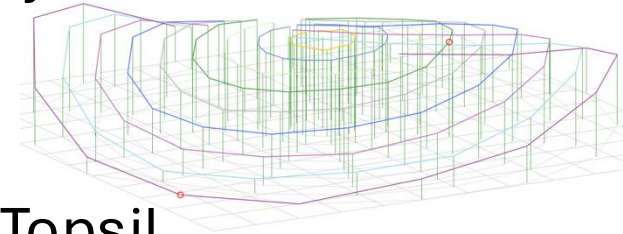

High-resistivity silicon by Topsil

→ deformation reduced by 1/10 but max  $\Phi 200$

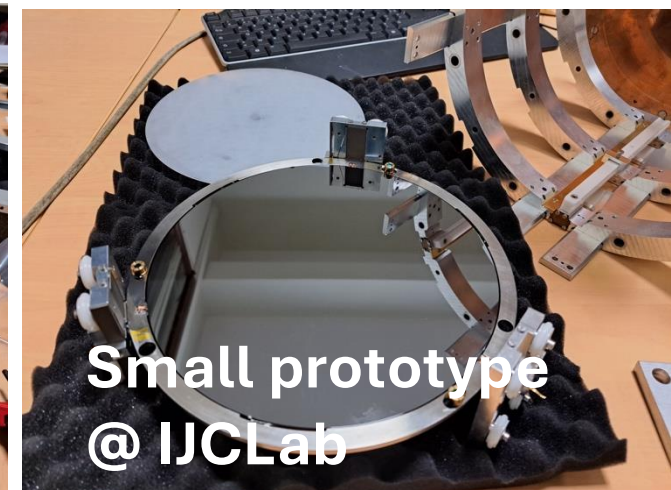
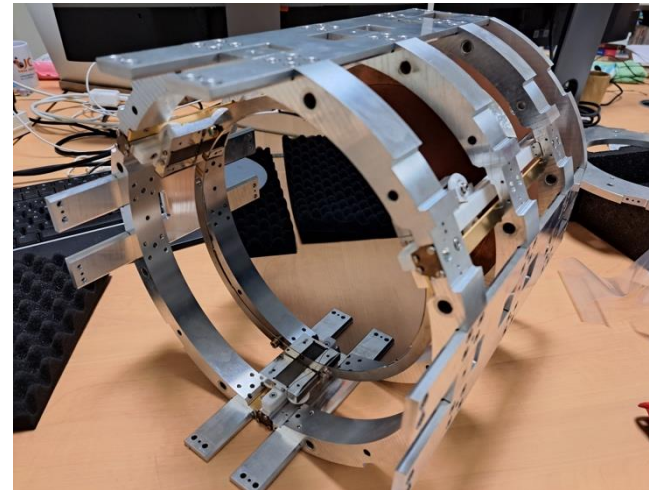



# IJCLab's contributions to MADMAX 2: MW absorbers → noise mitigation

## Qualification of absorbers

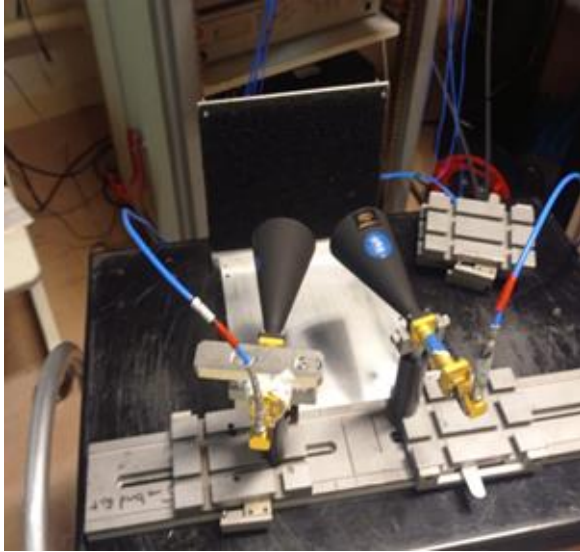

(S31) - Absorber A

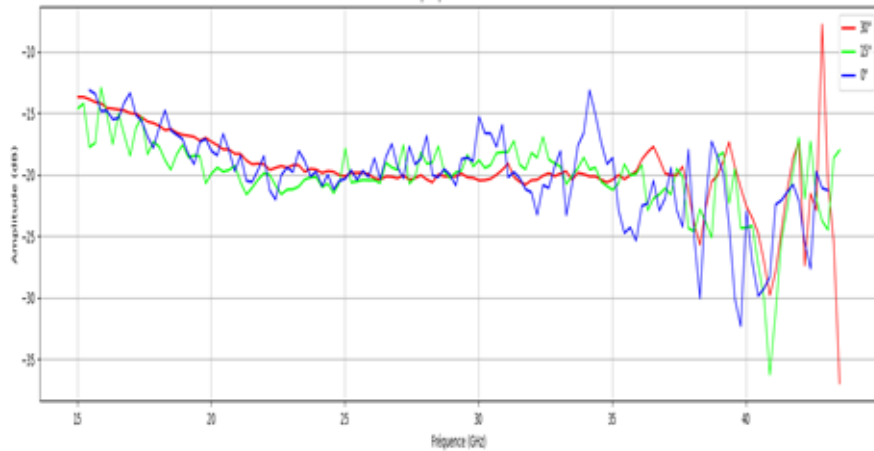

## Mounting on the support



## Installation at UHH

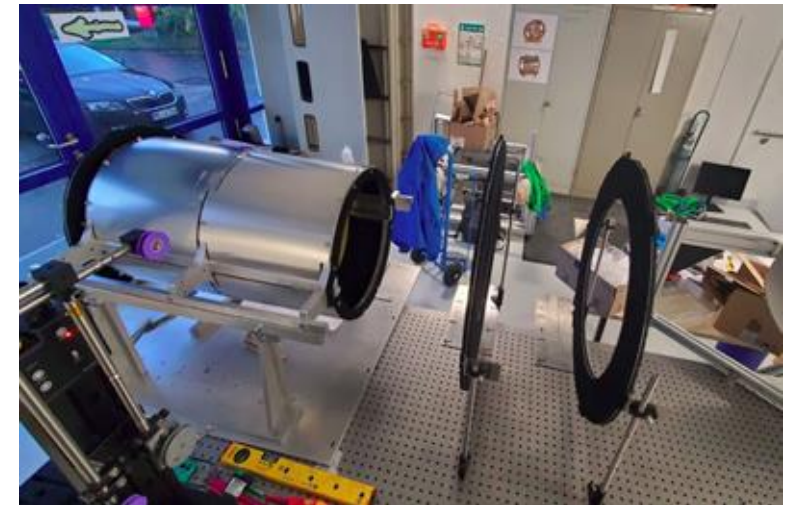
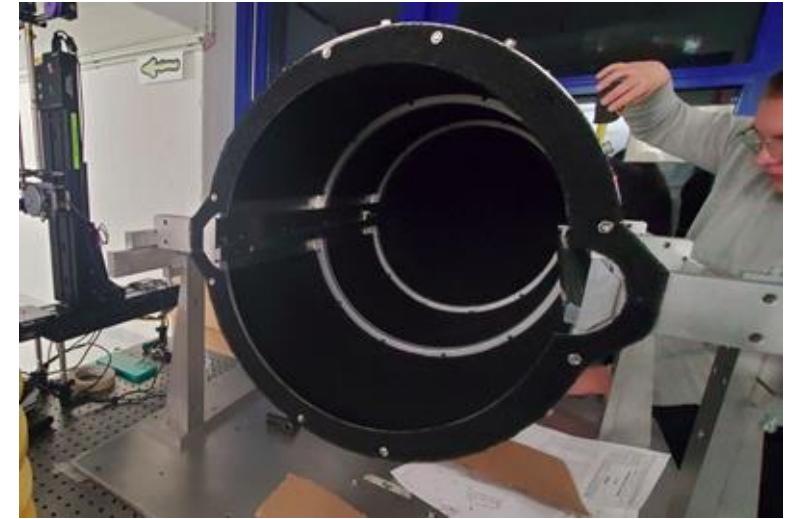



# Conclusion and future prospects

## Axion searches

- Axions are the solution of the strong CP problem and can be an excellent dark matter candidate
- Dark matter axions behave as a classical wave [Caldwell et al., PRL 118, 091801 \(2017\)](#) [Millar et al., JCAP01\(2017\)061](#)
- Addressing  $\sim 100\mu\text{eV}$  axions has been challenging due to lacking overlap with microwaves

## MADMAX : dielectric haloscope

- **Boost** the axion signal in periodically placed dielectric disks
- Technical milestones (tuning, magnet feasibility, boost factor  $\beta^2$ )

## Two small prototypes

[Egge, JCAP04\(2023\)064](#) [Egge et al, JCAP04\(2024\)005](#)

- Close booster  $\rightarrow$  mode-based  $\beta^2$  determination
- Open booster  $\rightarrow$  reciprocity-based  $\beta^2$  determination
- **Successful 1<sup>st</sup> searches in axions and dark photons!**

[MADMAX collaboration, PRL 134, 15, 151004 \(2025\)](#) [MADMAX collaboration, PRL 135, 041001 \(2025\)](#)

## We are working on the next larger prototype

[D. Kreikemeyer et al. JINST 20 T02005 \(2025\)](#)

- Cryogenic calibration: analysis on-going
- Large cryostat under commissioning & large optics & noise har
- Intermediate magnet to be installed at DESY

## Next physics runs are planned during LS3 at CERN

## Quantum sensors are under discussions for further upgrade

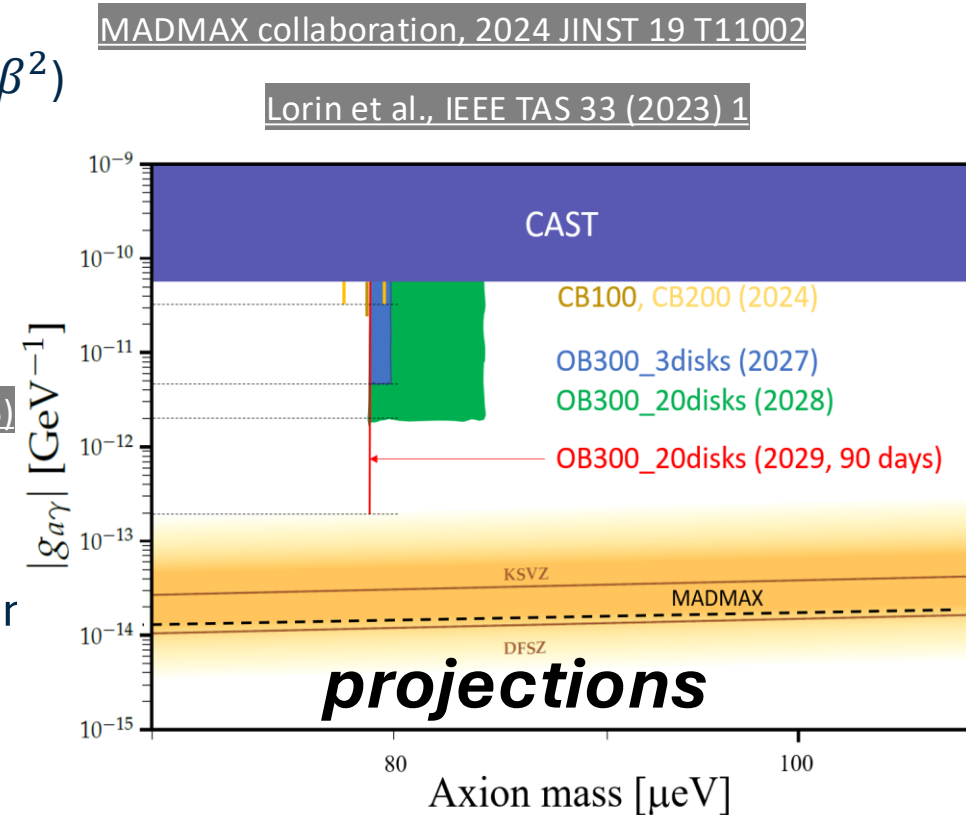

# More pedagogical lectures of mine

- 90 min x 3 lectures on axions in Nagoya University
  - <https://indico.kmi.nagoya-u.ac.jp/event/15/overview>
- 1-week lectures + hands-on about RF for axions in Hamburg University
  - <https://indico.desy.de/event/50207/>
- Textbooks (we do not have established textbook for axions ☹️):

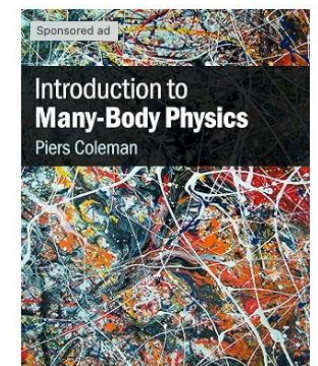
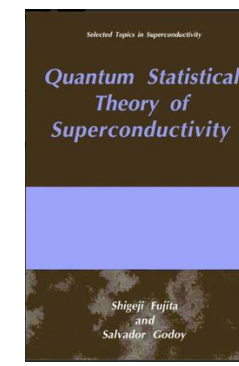
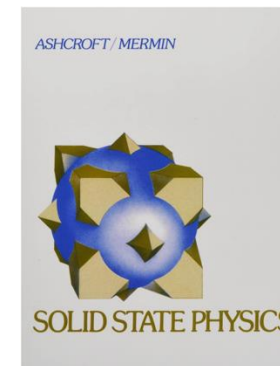
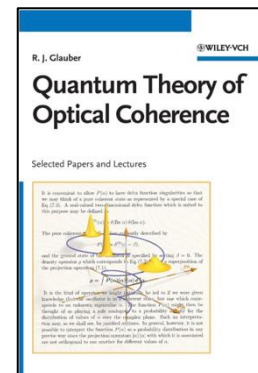
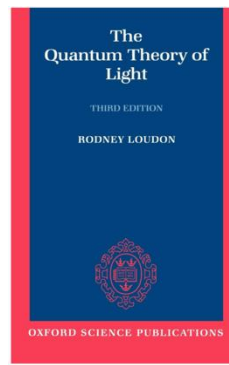
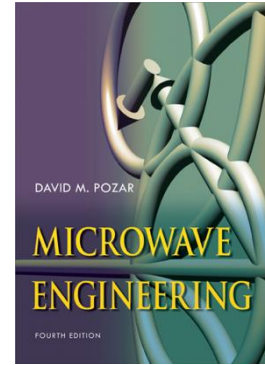
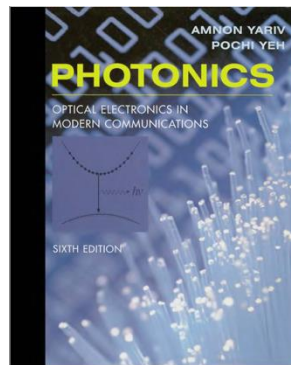
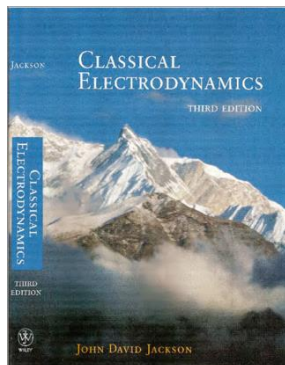

backup



# Open booster prototype for dark photons

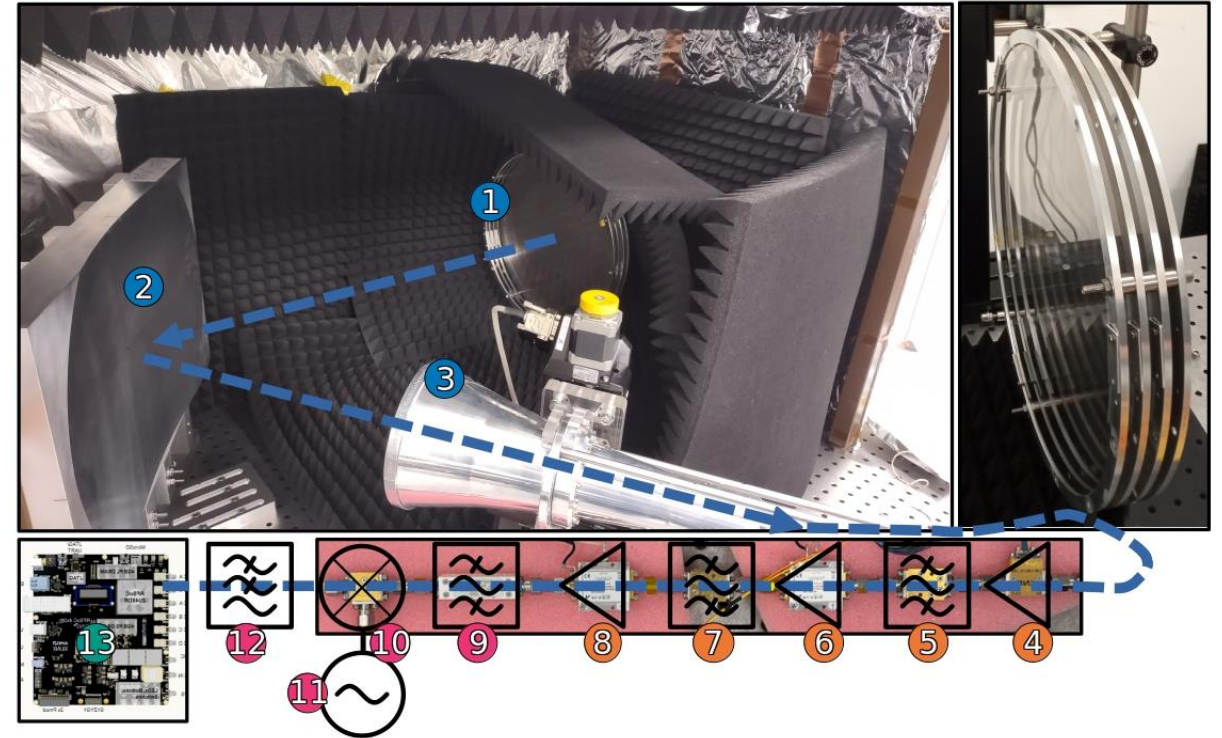
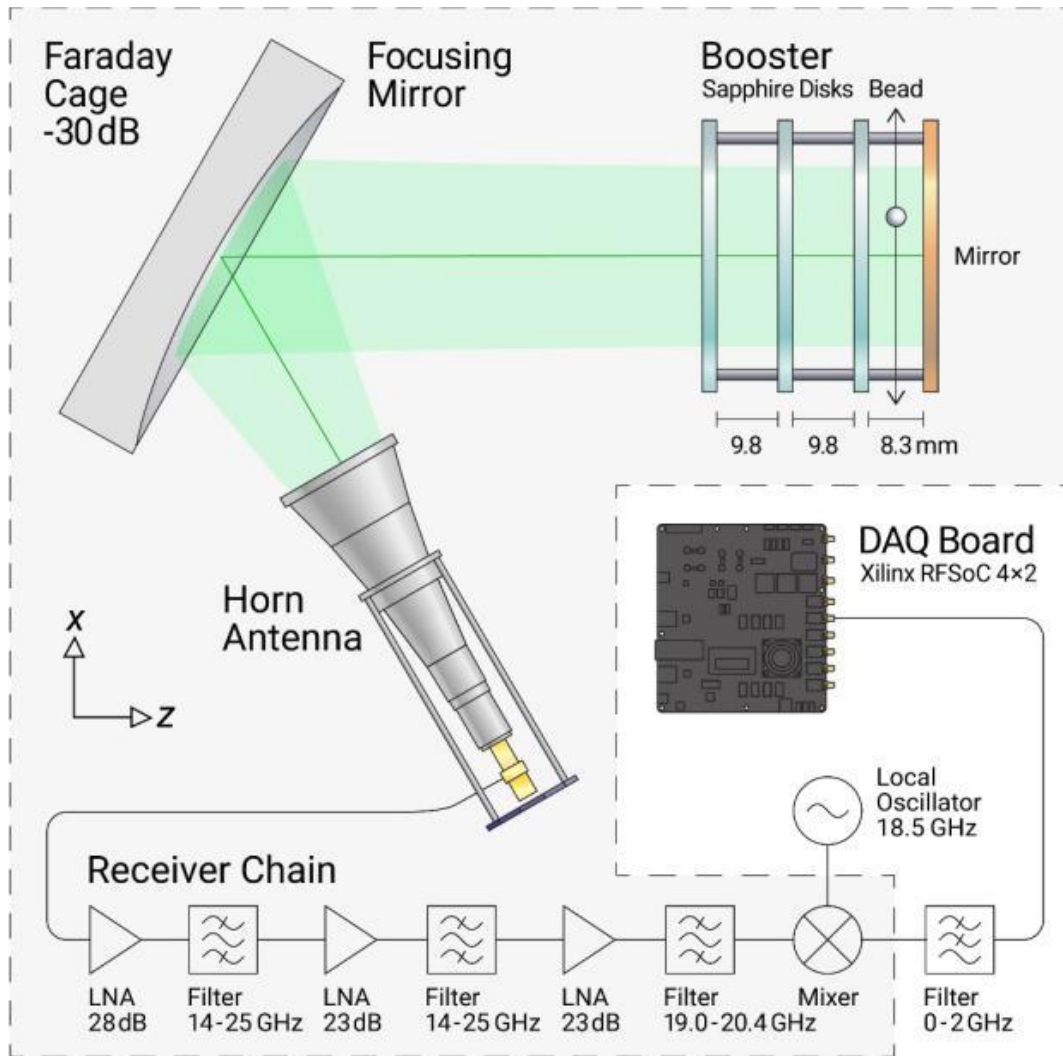

- Close booster may not be scalable  
→ Open setup is a crucial milestone
- The MW reflection data is not as clear as that of close boosters (open boundary)  
→ Model & fitting approach was challenging ☹️



# $\beta^2$ determination in open booster setup

## Lorentz reciprocity approach

$$P_{sig} = \frac{1}{2} \text{Re} \int_S (\mathbf{E}_a \times \mathbf{H}_a^*) \cdot d\mathbf{S} \propto \left| \int_V (\mathbf{E}_R \cdot \mathbf{B}_0) dV \right|^2$$

Unknown axion fields      ↑      Measurement observable!

Boost factor can be determined via electric field of MW excited from outside

$$\beta^2 = \frac{P_{sig}}{P_0} \propto \left| \int_V \mathbf{E}_R dV \right|^2$$

Electric field can be obtained through the beads-pulling method (b)

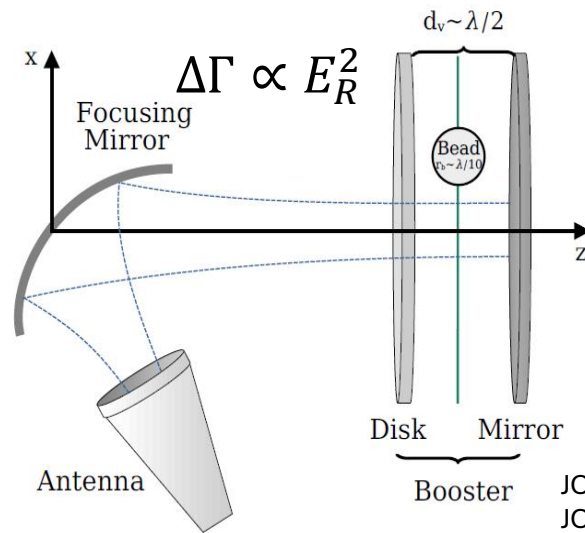
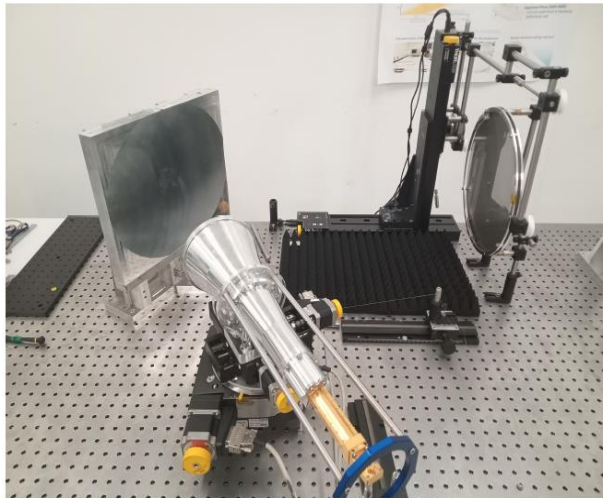

JCAP 04 (2023) 064  
JCAP 04 (2024) 005

→  $\beta^2$  determined with ~15% errors

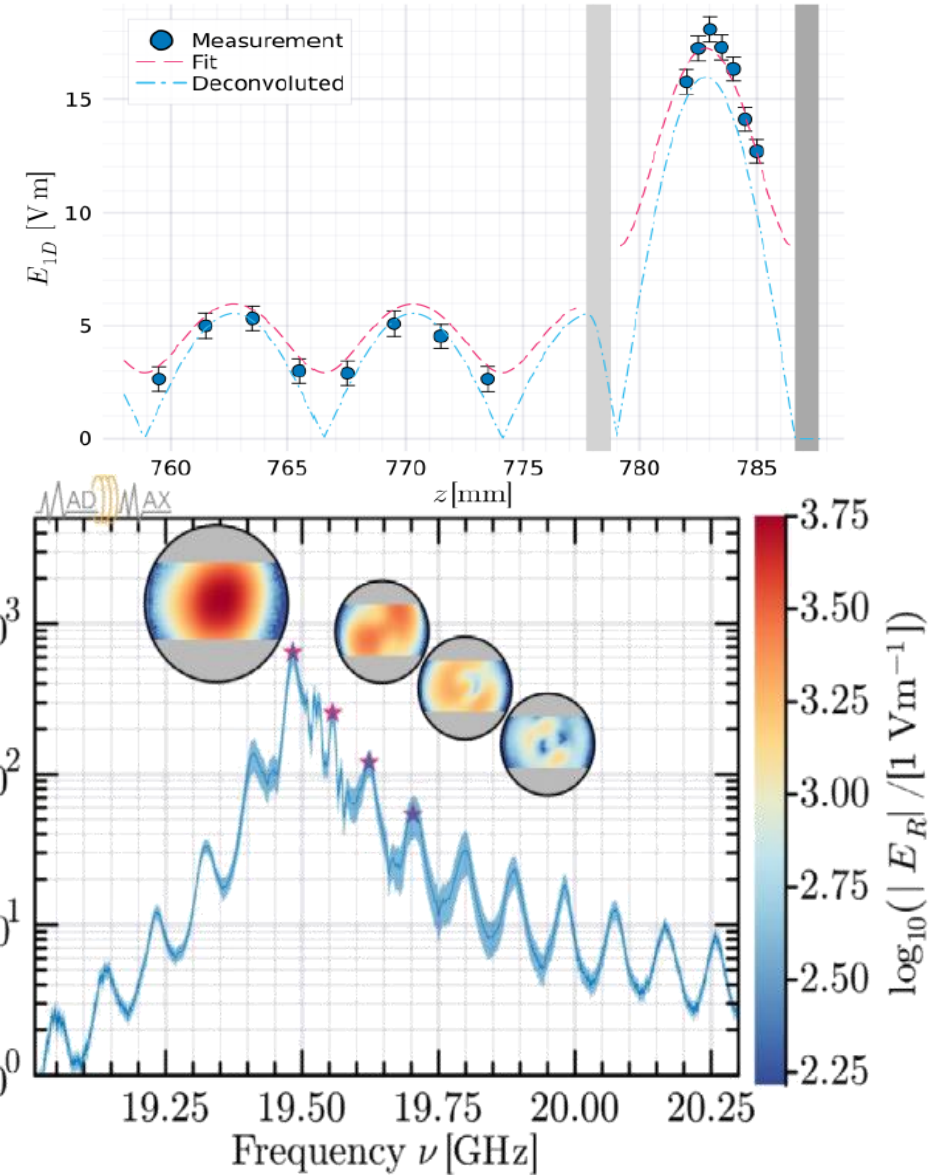



# First result of dark photons search

- No excess observed in acquired power spectra
- Limits on kinetic mixing  $\chi$  between photon and DP for  $m_{DP}$  [78.6, 84.0] meV
- Limits better than existing ones by up to x1000 with modest system [few small disks]  
→ Proving substantial potential of the MADMAX concept

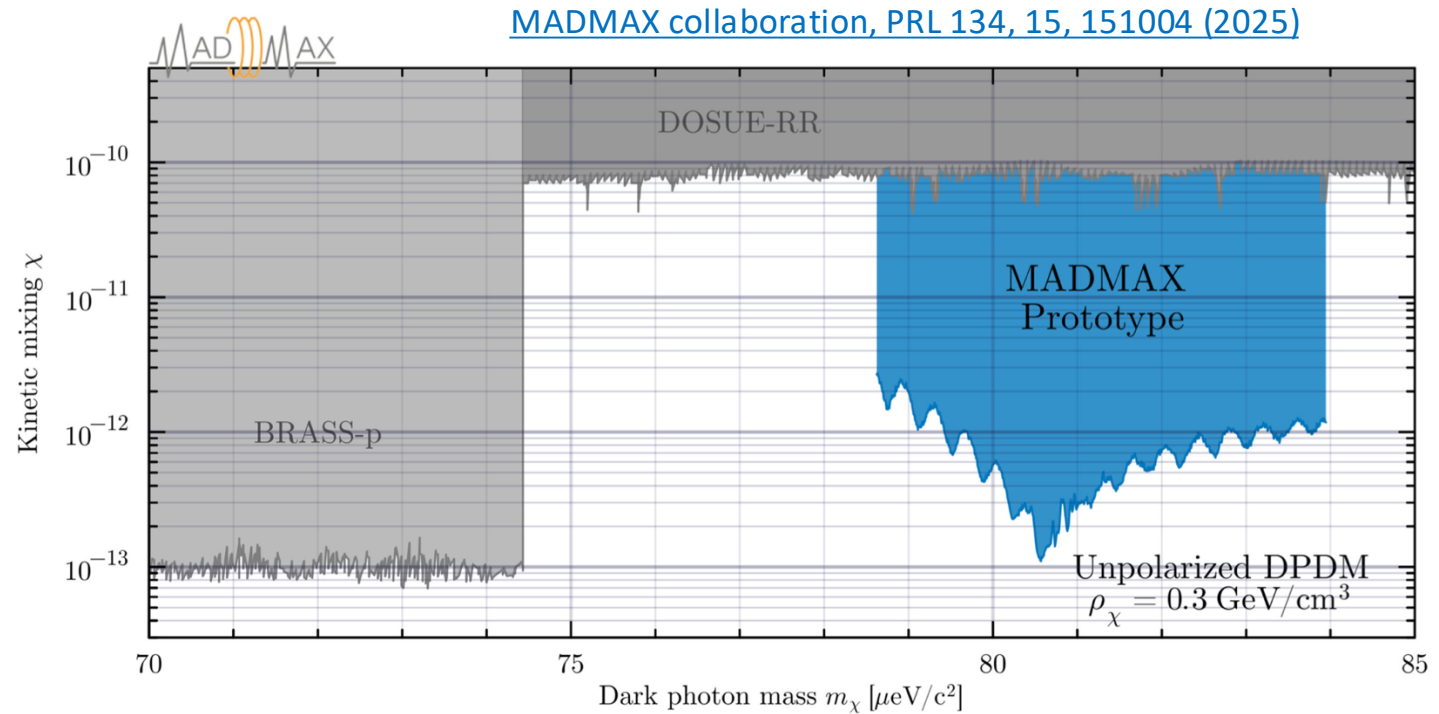
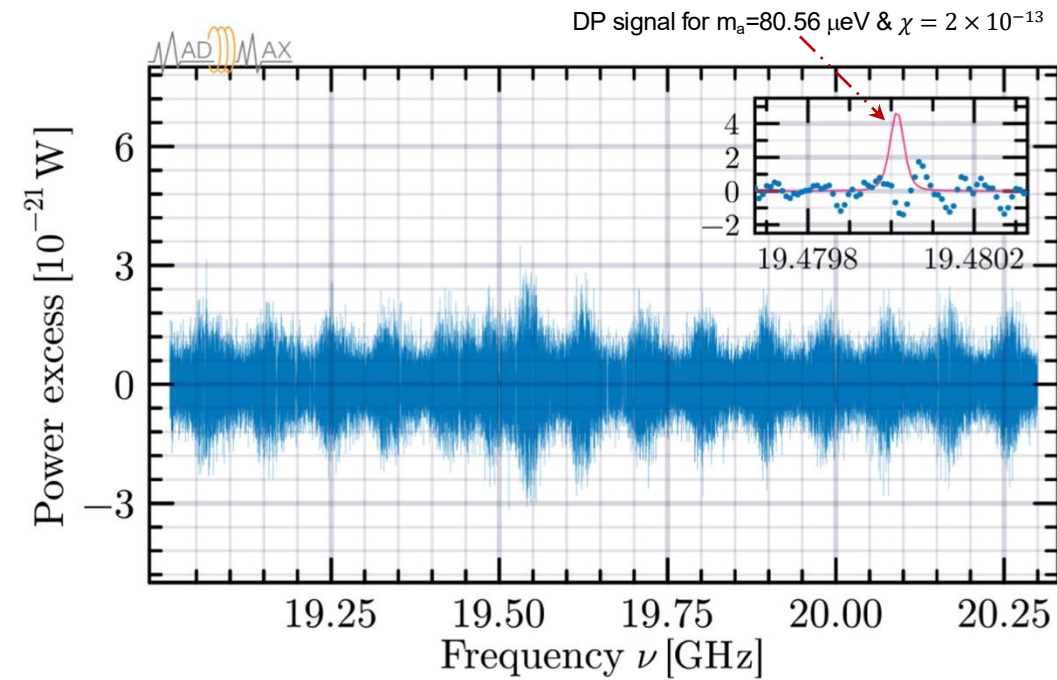

**First dark matter DP search with the dielectric haloscope!**



# DP limits in open and closed boosters

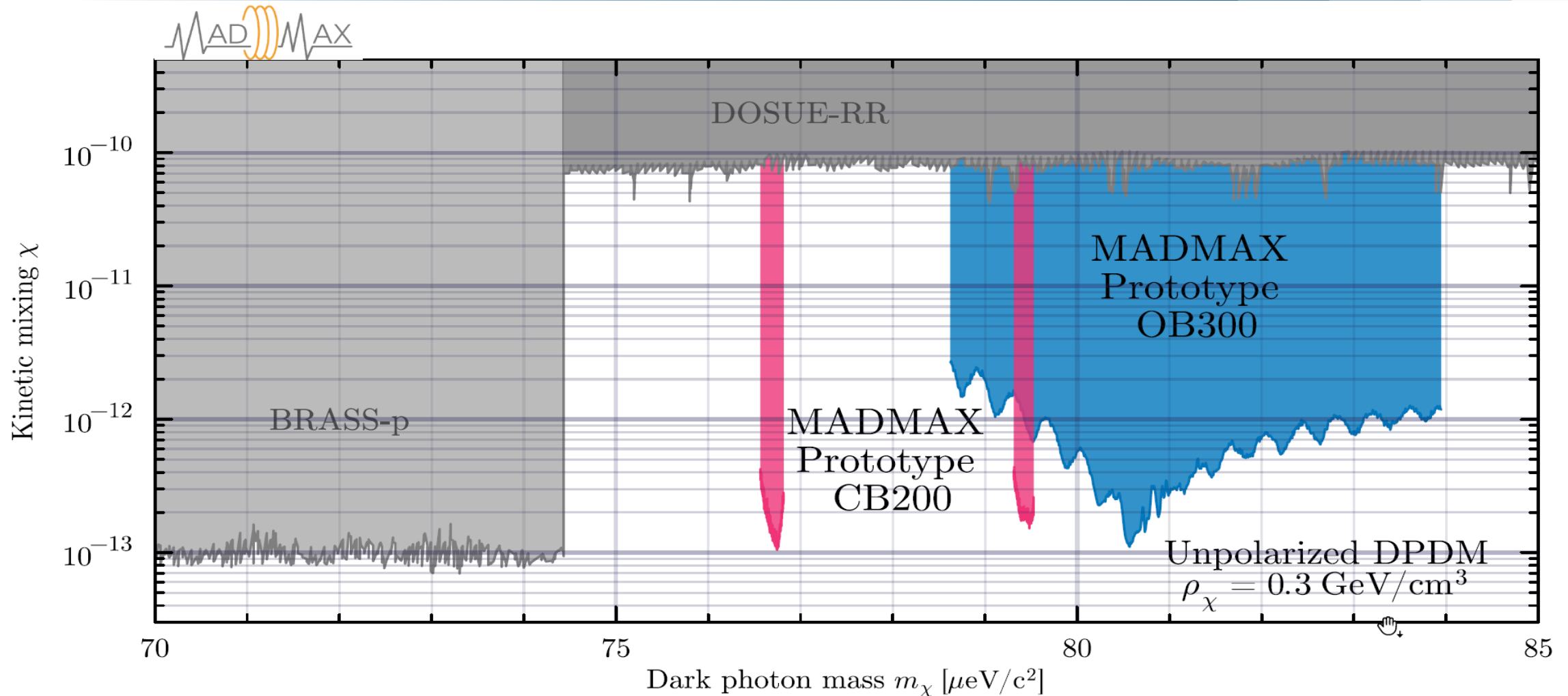

## CB200 & OB300 Dark photon dark matter limits complementary

<https://arxiv.org/abs/2509.06398>

[http://vietnam.in2p3.fr/2025/tmex/transparencies/5\\_friday/morning/DM4/04\\_Dabhi.pdf](http://vietnam.in2p3.fr/2025/tmex/transparencies/5_friday/morning/DM4/04_Dabhi.pdf)