



Development of innovative electronics for a radiometer aimed at axion dark matter searches

Morane GAUTIER

Theme: **Instrumentation**



Agenda:

- Experiment
- Radiometer
- Preliminary results
- Outlooks



DAWA experiment

- Astrophysic problem: Dark Matter
- Standard Model paradox:
Strong CP problem: $\theta_{\text{strong}} \leq 10^{-10}$
 $\theta_{\text{strong}} = 0$?
- \Rightarrow New symmetrie \Rightarrow new particule: **axion**

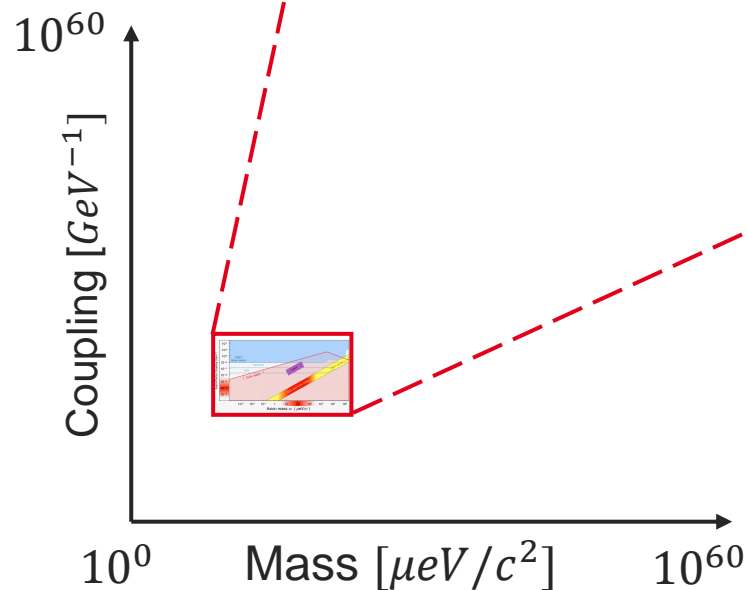
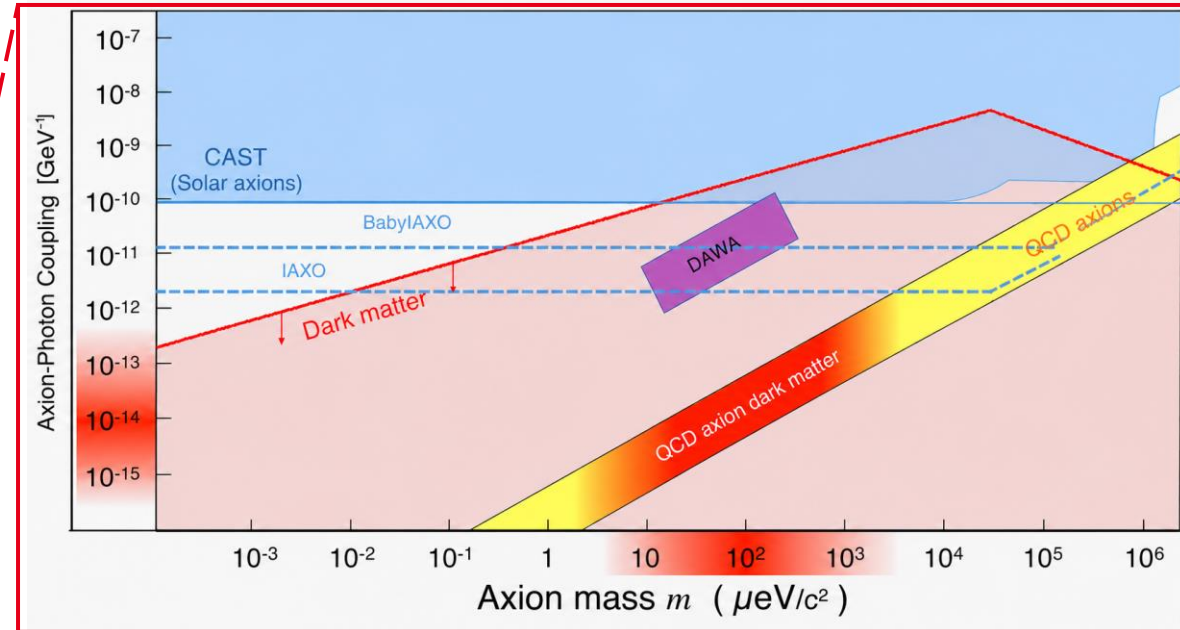

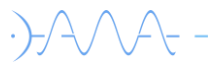

DAWA experiment

Dark matter Axion Wideband Approach

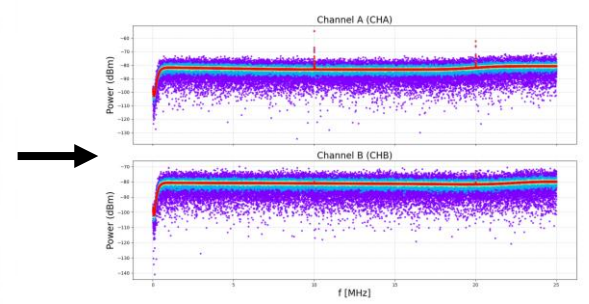
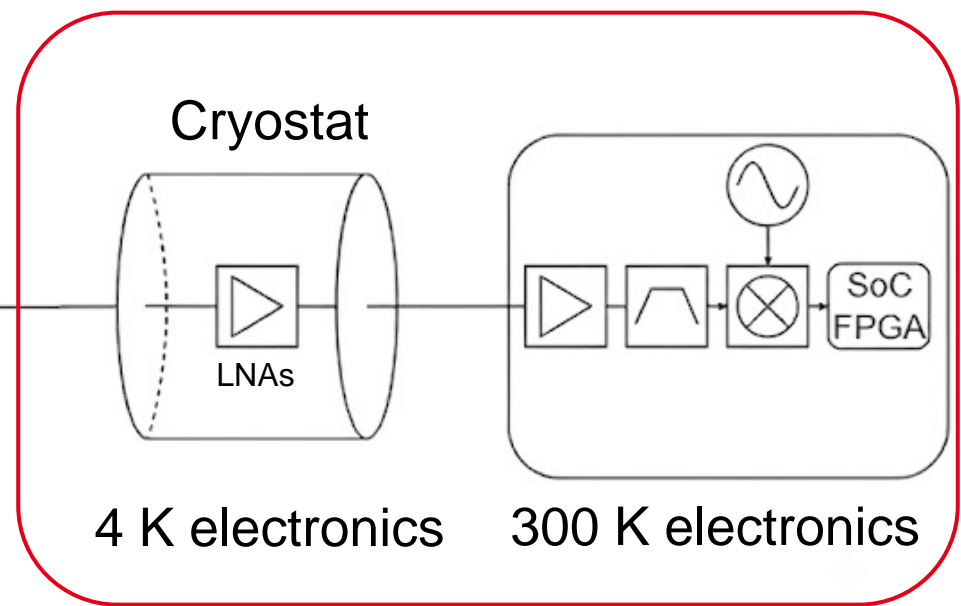
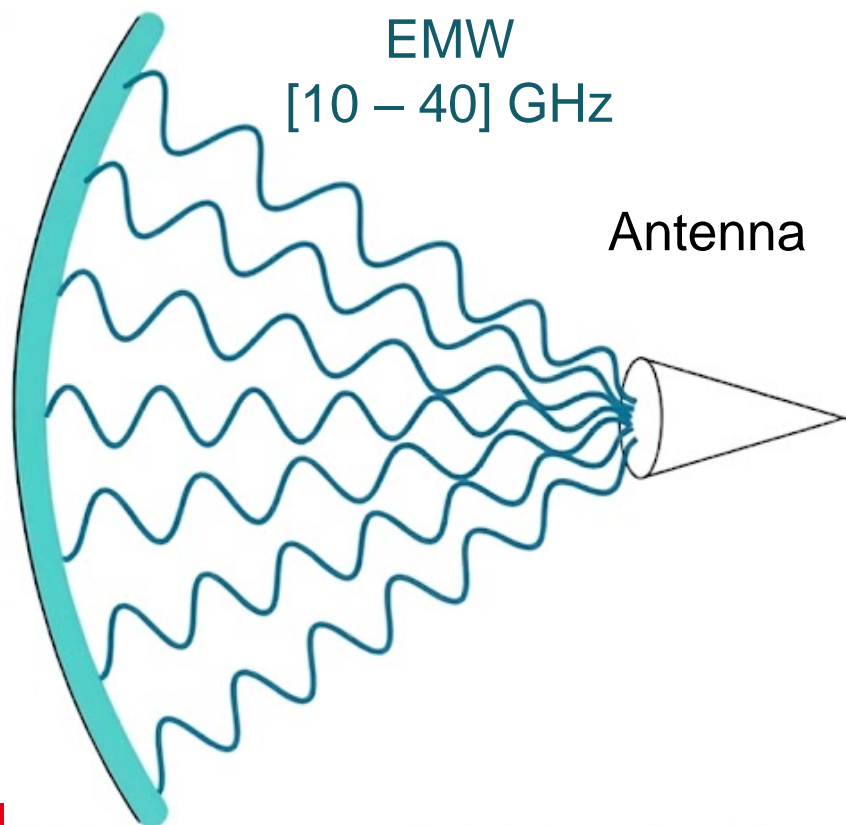
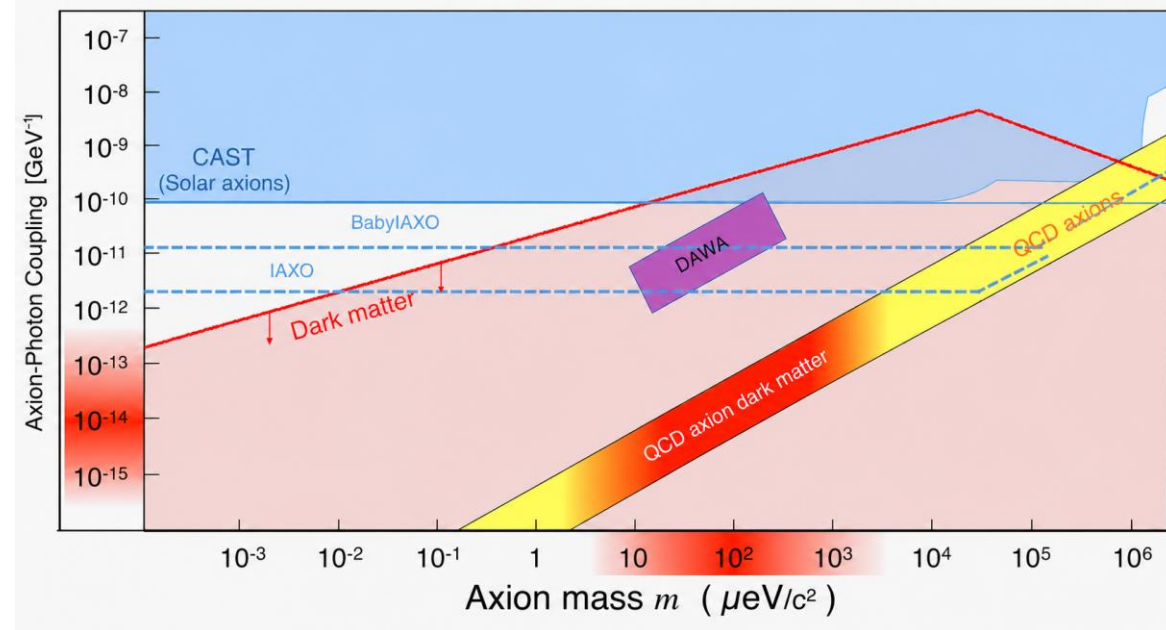

Frequency spectrum



DAWA experiment

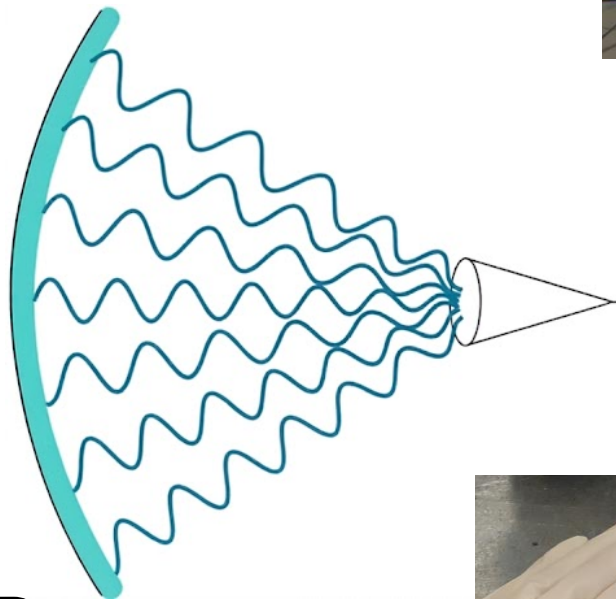
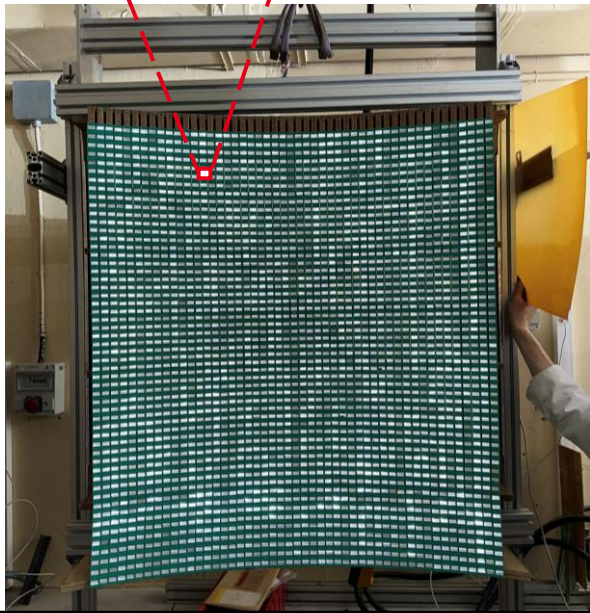
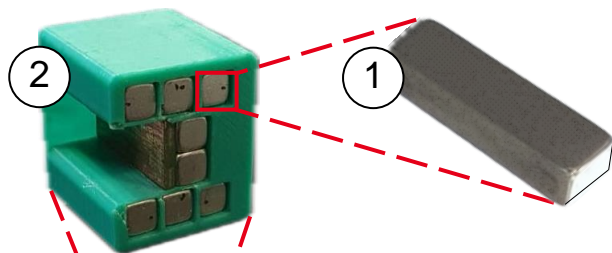

Cryostat (4)

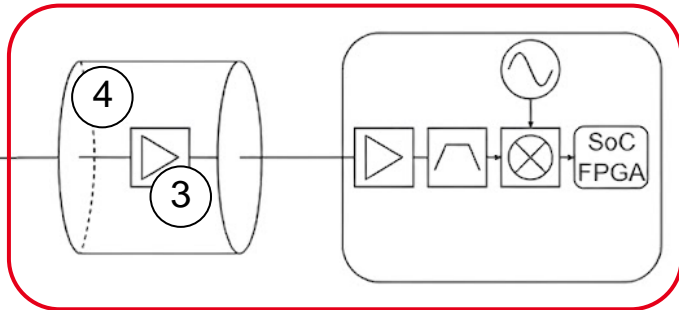

Dish: array (1.2x1.2m) of magnet modules (1, 2)

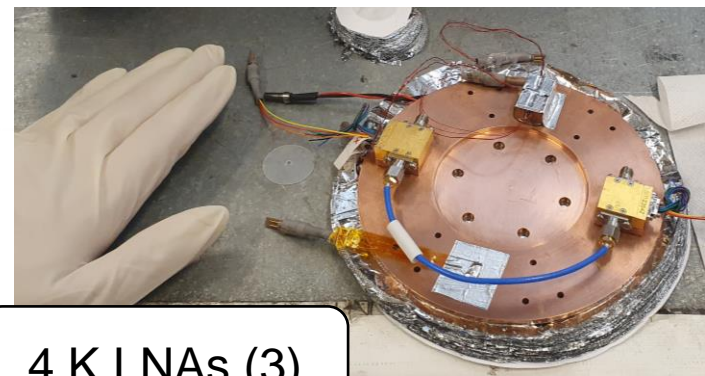

4 K LNAs (3)

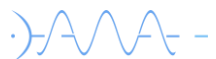

DAWA radiometer

Experiment objectives

- Radiometer output: power spectral density
- Bandwidth: 10 – 40 GHz ($50 - 150 \mu\text{eV}/c^2$)
- Sensitivity goal: 10^{-25} W
- Axion signature: maxwellian power excess in random RF noise spectrum

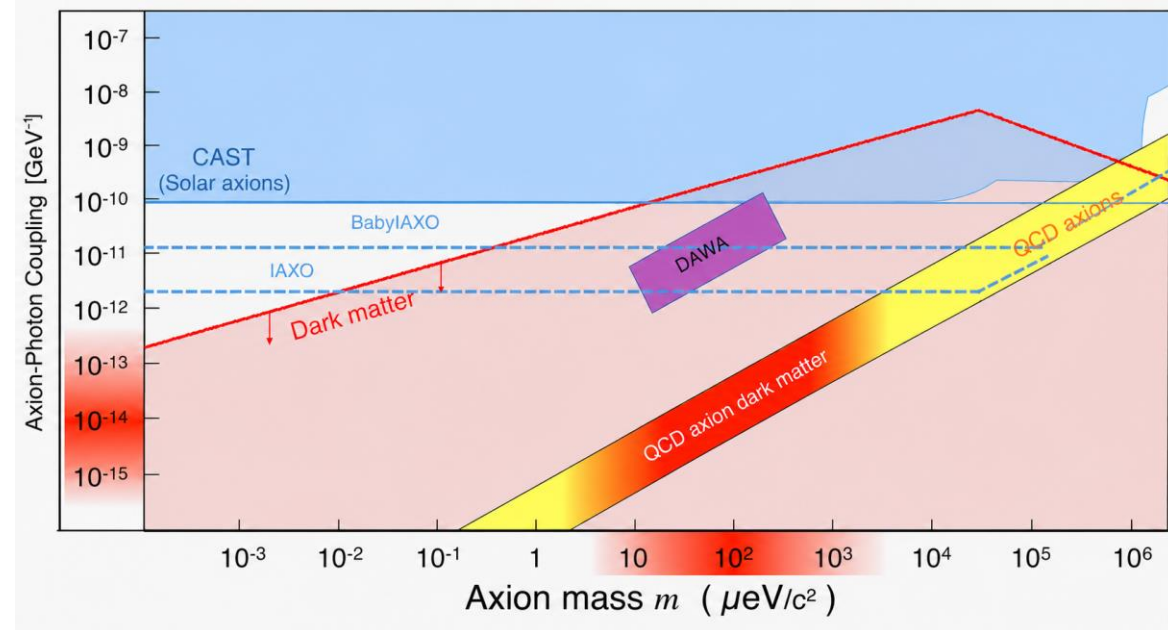

Expected maxwellian power excess @10 GHz

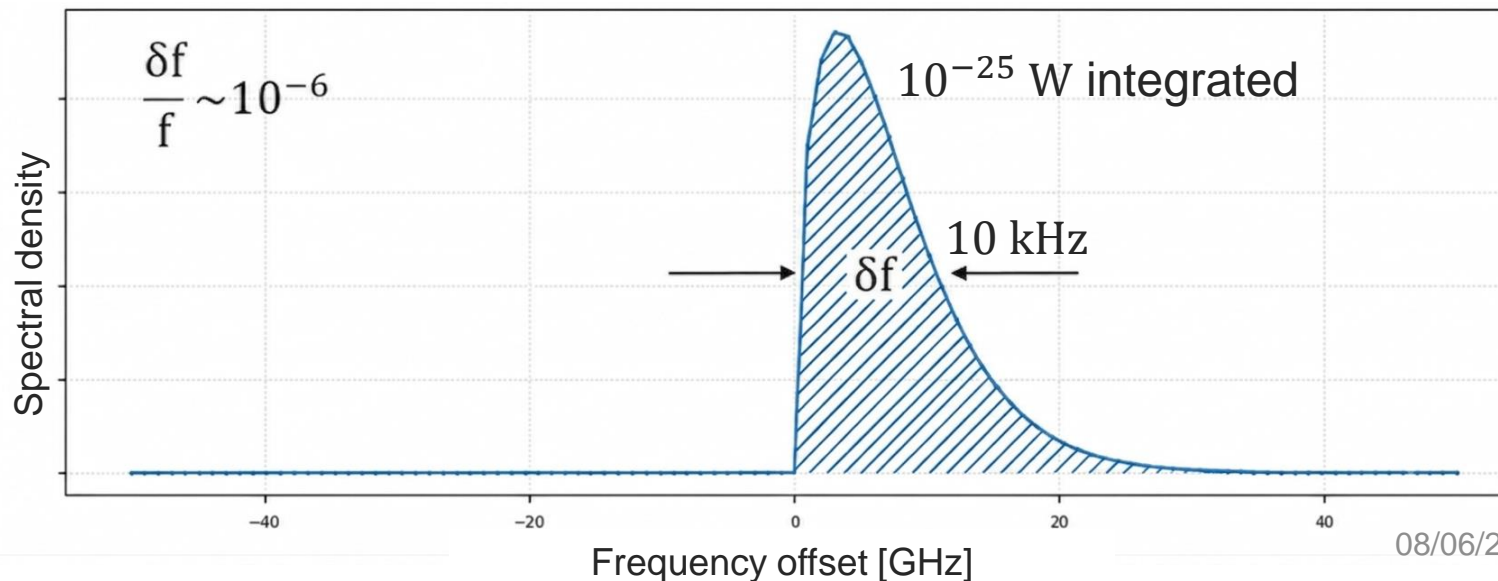



DAWA radiometer

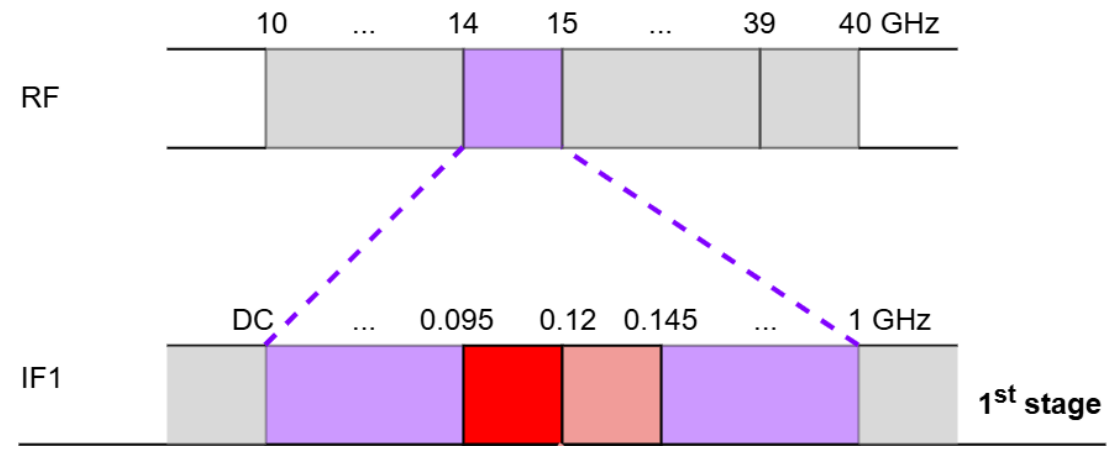
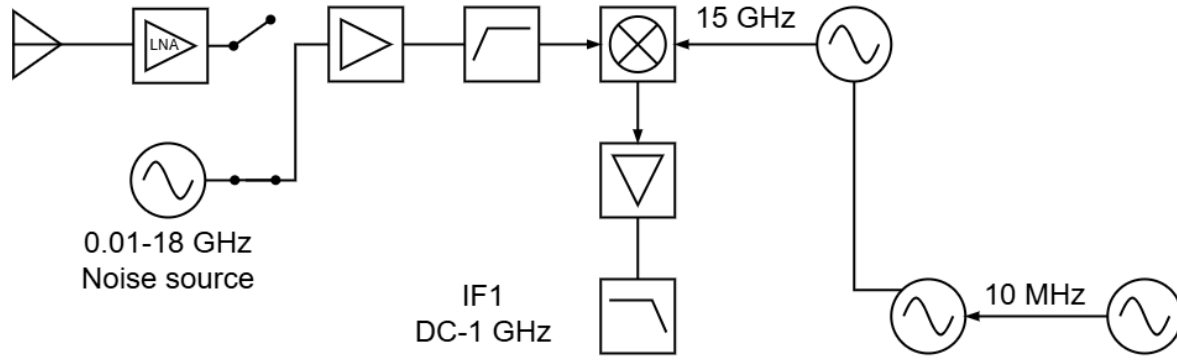

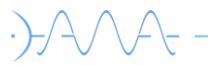

DAWA radiometer

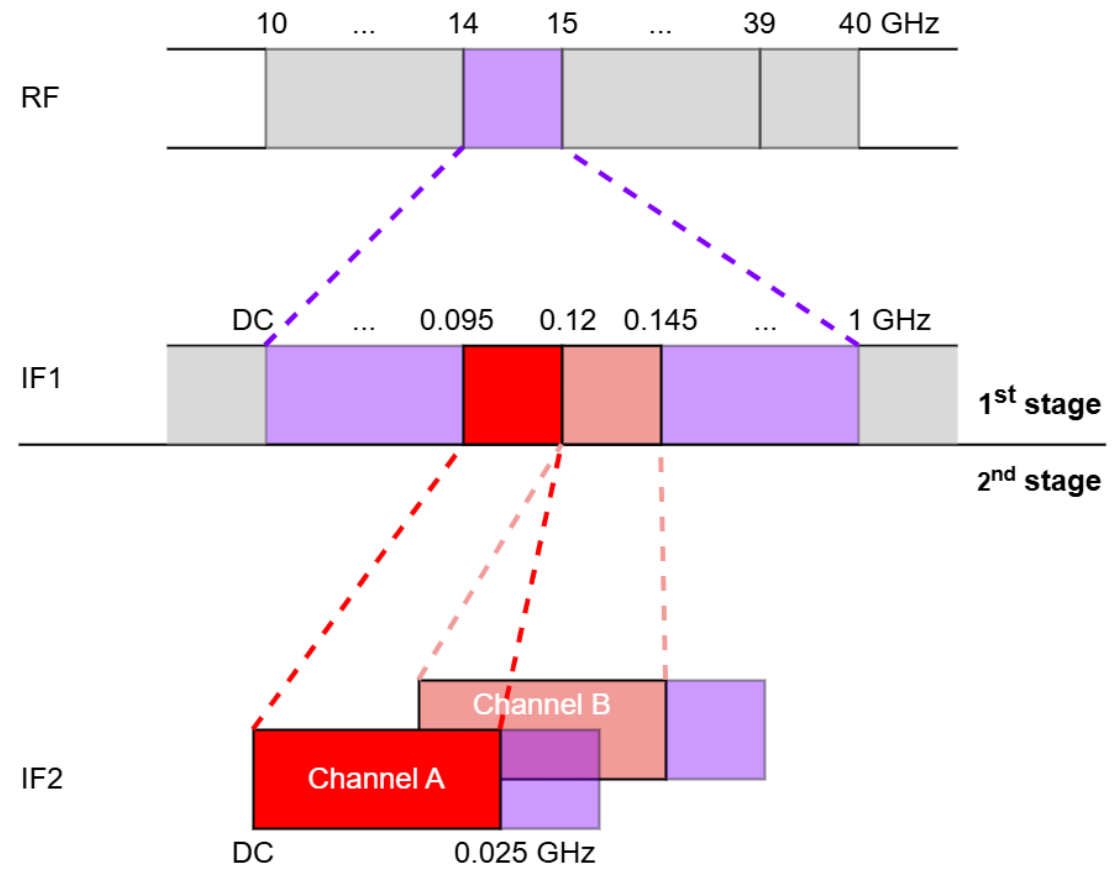
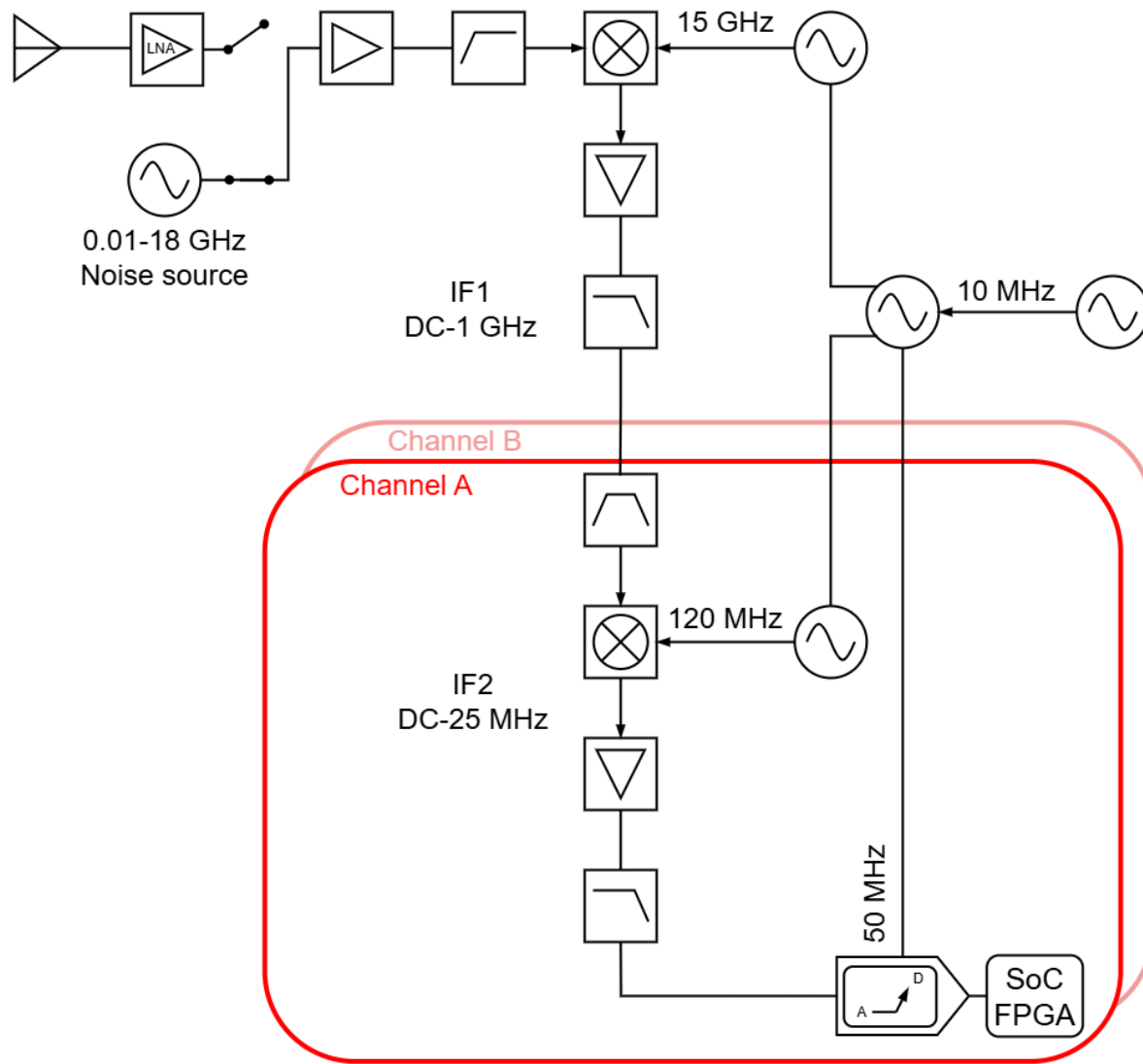

DAWA radiometer

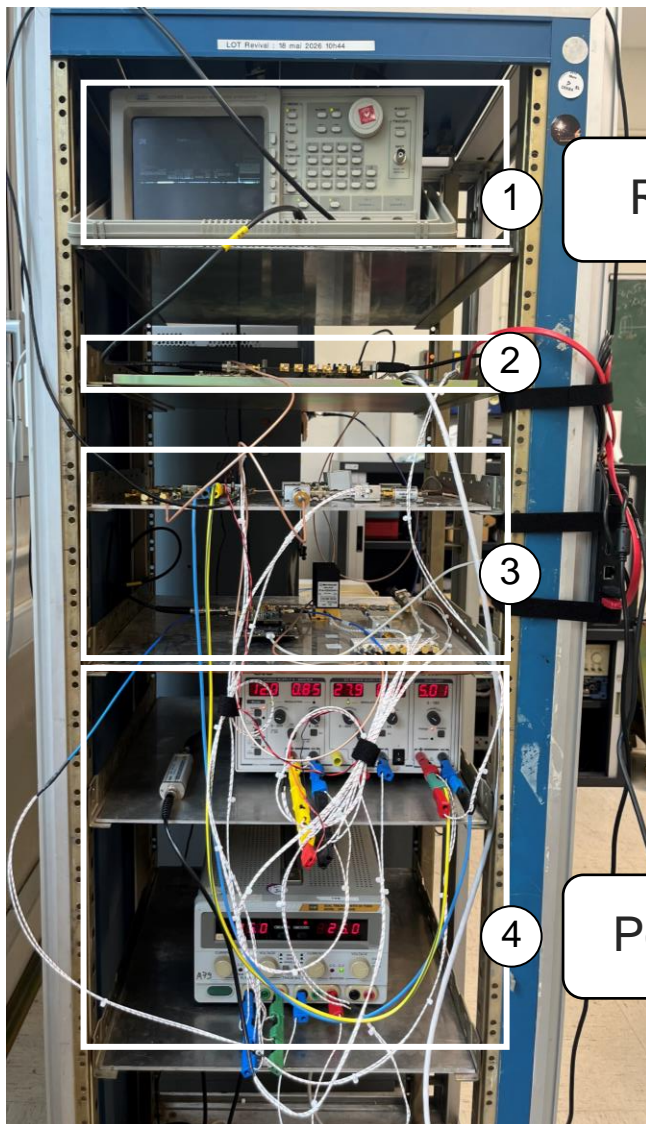

1

Reference clock (1)

2

Synchronization and digital block (ADC, SoC FPGA) (2)

3

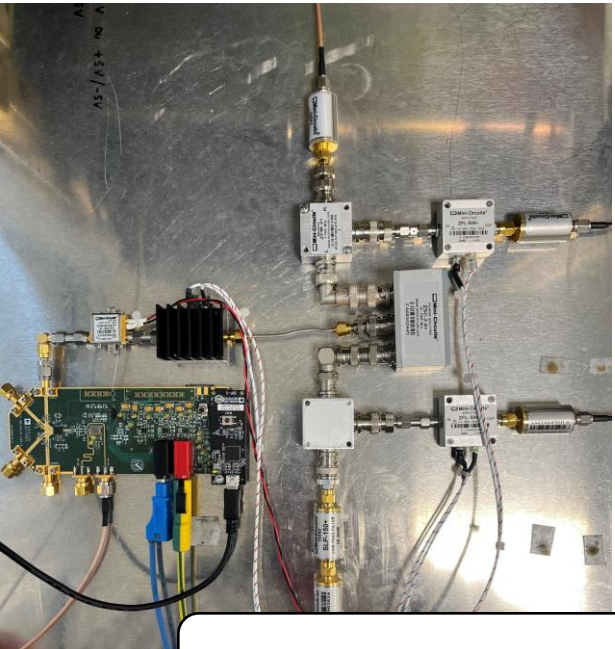

RF, mixing and IF electronics (3)

4

Power supplies (4)

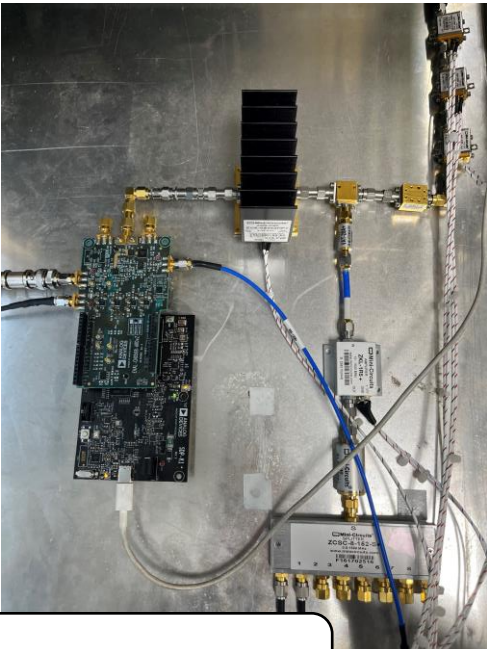

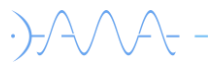

Preliminary results of 300 K electronics

- Streaming FFTs and no dead time
- Input: noise source
- $P_{out} = -80$ dBm
- Sensitivity increases with averaging
- Deterministic spurs

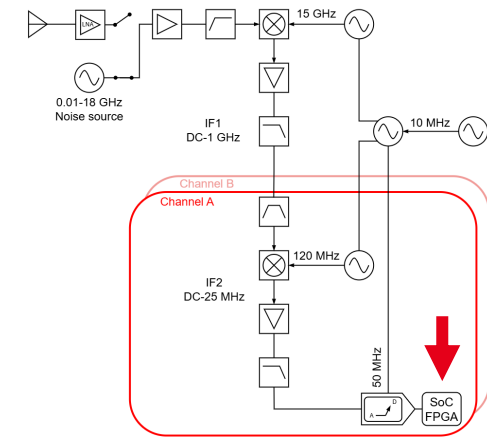

Frequency power spectrum
 M: 65536 pts | Fs: 50.00 MHz | RBW: 0.763 kHz

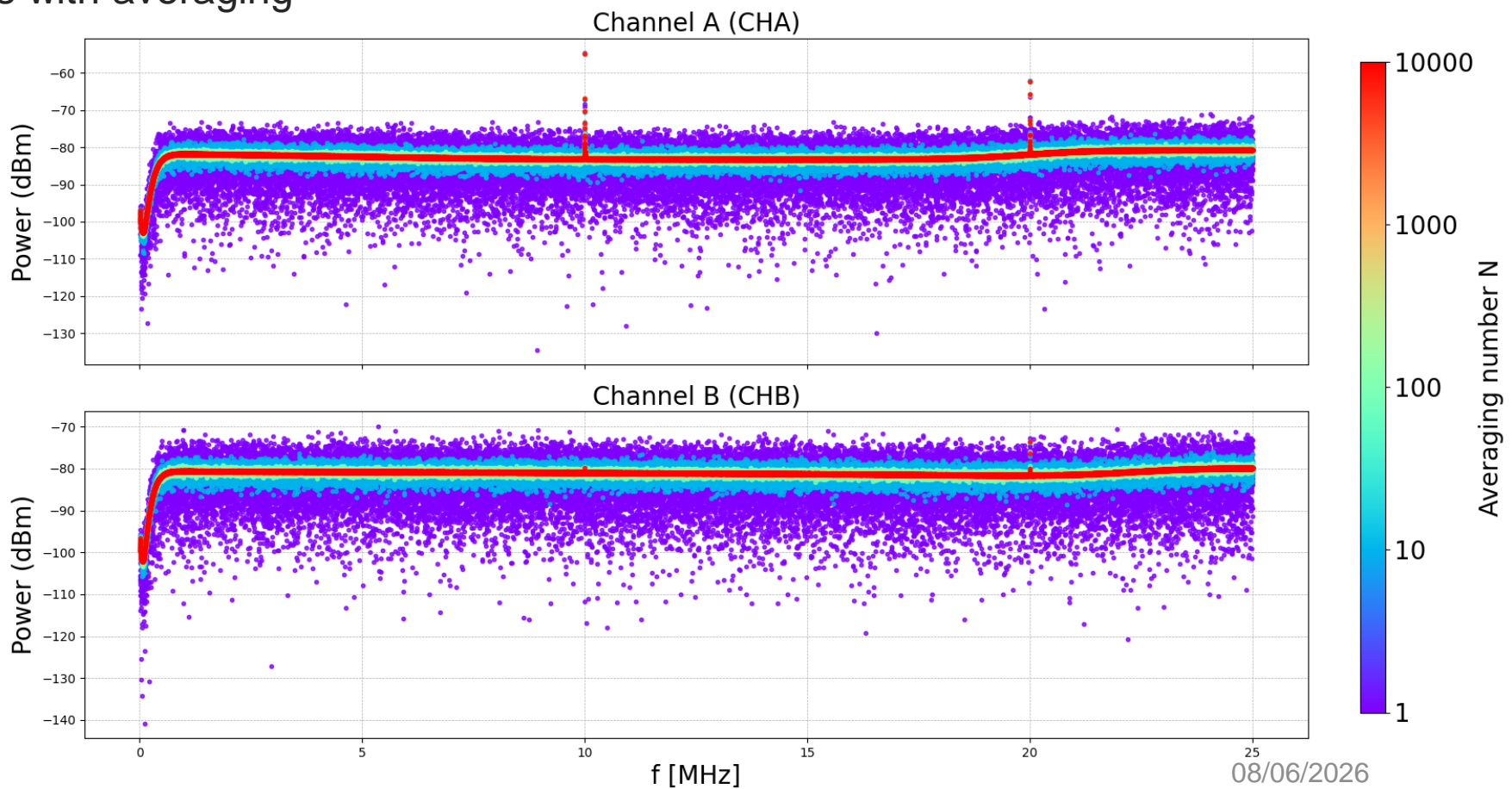

Outlooks

- Test measurements with 4 K electronics
- Preliminary DAWA data taking
- « Scaling Up »:
 - 4 x 25 MHz bandwidth mezzanines
 - 10 mezzanines
- Super DAWA experiment...



irfu

Thank you !

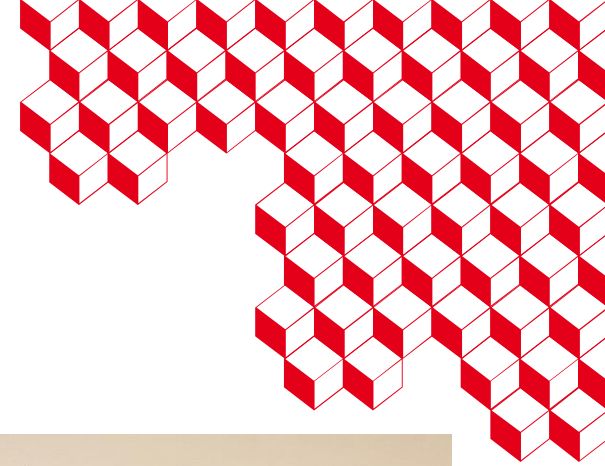



■ Backup slides

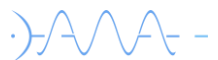

SoC FPGA utilization

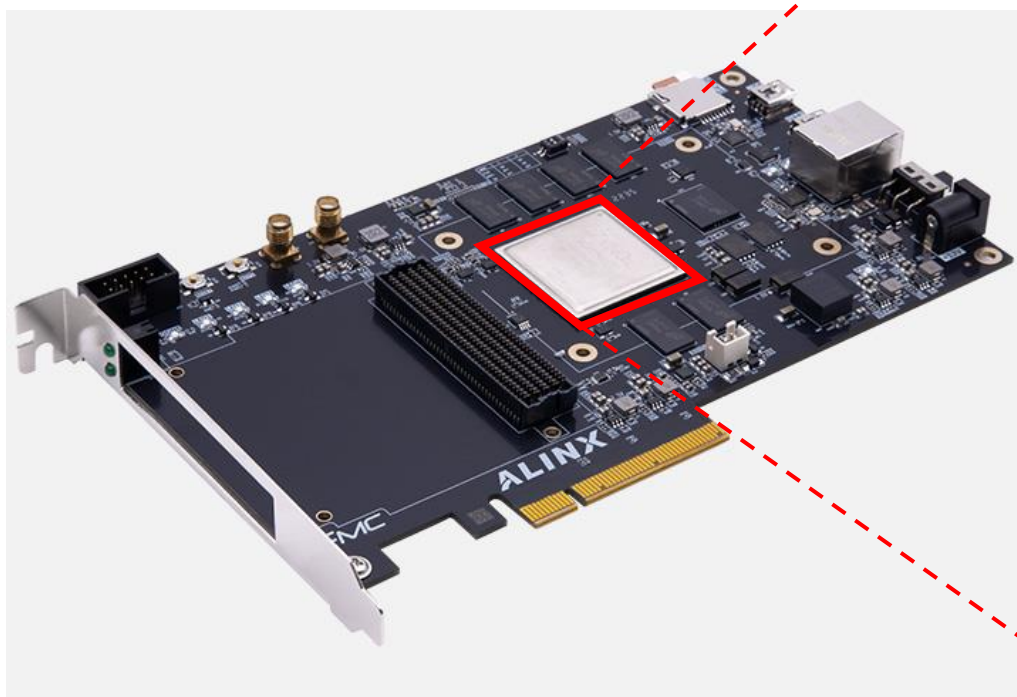
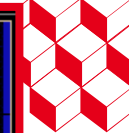

SoC AX7450B

