

Quarkonia production in heavy-ion collisions with ALICE

Sara Garetti

Physics motivation

$t = 0$: Big Bang \rightarrow universe
underwent rapid expansion and
extreme heating

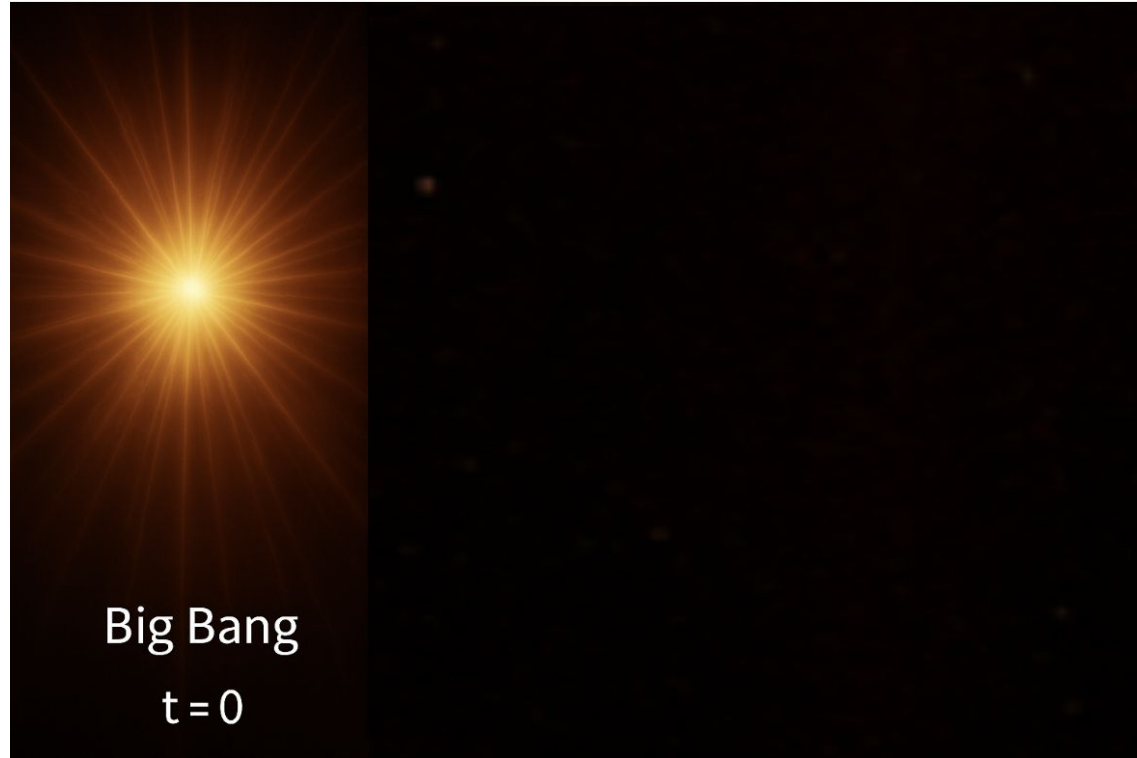

Physics motivation

$t = 0$: Big Bang \rightarrow universe underwent rapid expansion and extreme heating

$t \sim 10 \mu\text{s}$: **Quark-Gluon Plasma Formation** \rightarrow state of matter where **quarks** and **gluons** are **deconfined** and move freely

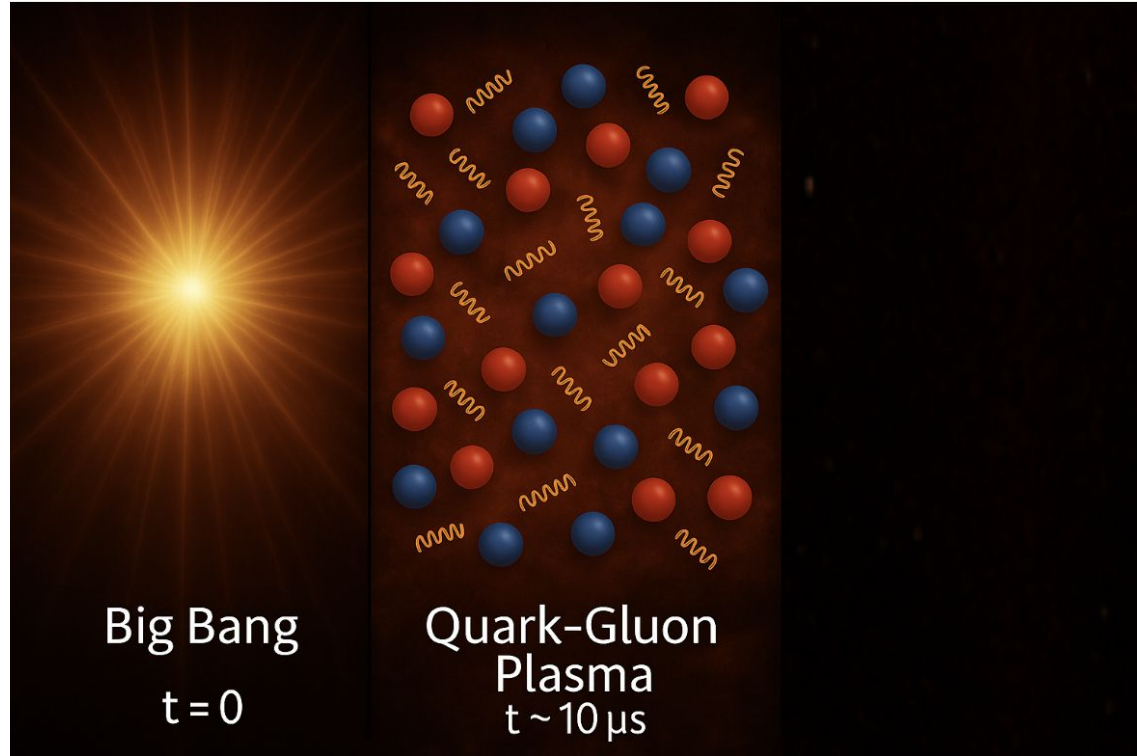

Physics motivation

$t = 0$: Big Bang \rightarrow universe underwent rapid expansion and extreme heating

$t \sim 10 \mu\text{s}$: **Quark-Gluon Plasma Formation** \rightarrow state of matter where **quarks** and **gluons** are **deconfined** and move freely

$t \sim 1 \text{ms}$: **Universe** continued to **cool down** \rightarrow **quarks** and **gluons** became **confined** in protons and neutrons, forming **nuclear matter**

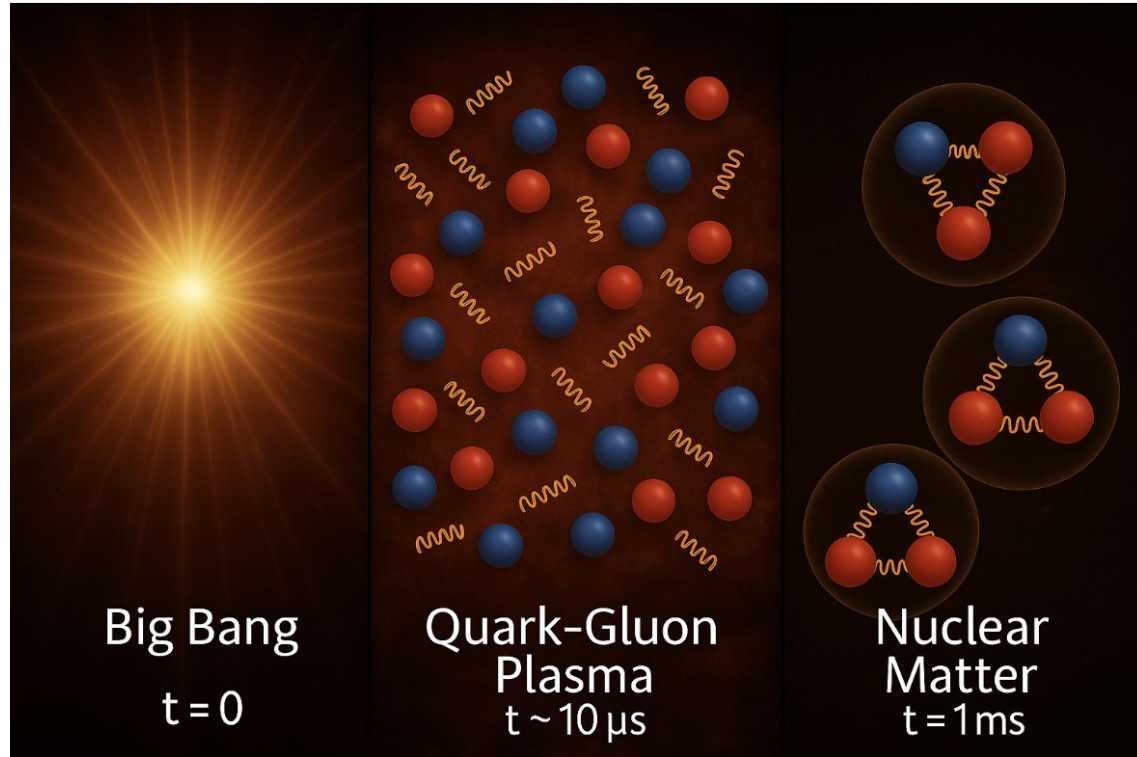

How to create the QGP in laboratory?

Pre-equilibrium: production of deconfined quarks and gluons + production particles with $p_T > 1 \text{ GeV}/c$

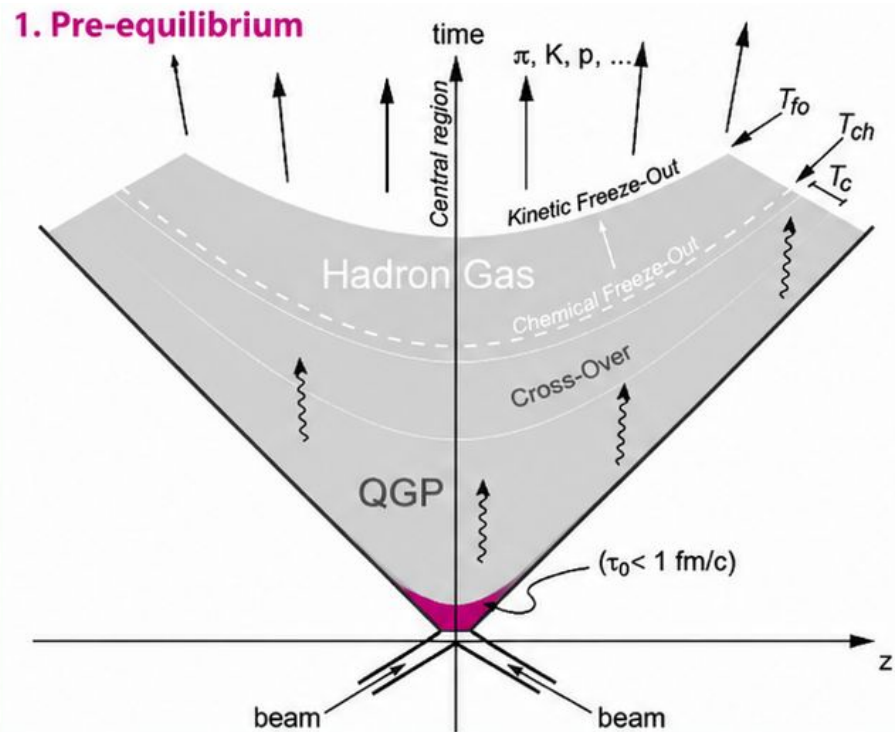

How to create the QGP in laboratory?

Pre-equilibrium: production of deconfined quarks and gluons + production particles with $p_T > 1 \text{ GeV}/c$

Thermalization: system rapidly expands and begins to convert into hadron gas. **Mixed phase**

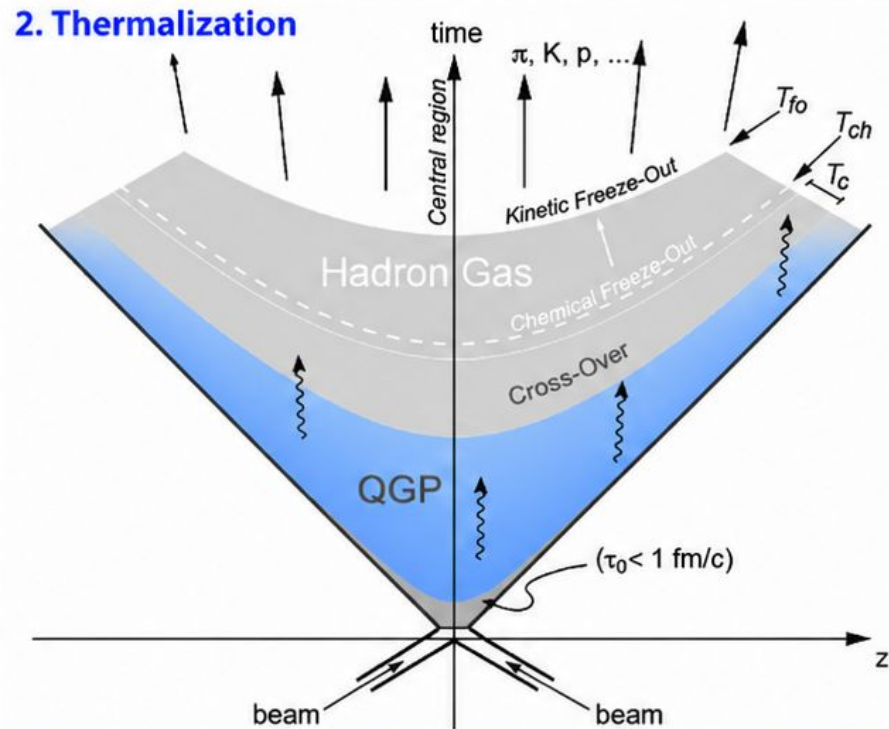

How to create the QGP in laboratory?

Pre-equilibrium: production of deconfined quarks and gluons + production particles with $p_T > 1 \text{ GeV}/c$

Thermalization: system rapidly expands and begins to convert into hadron gas. **Mixed phase**

Hadronization: QGP quarks and gluons condensate in new hadrons.
QGP matter flavour composition fixed when hadrons stop to interact: **chemical freeze-out**

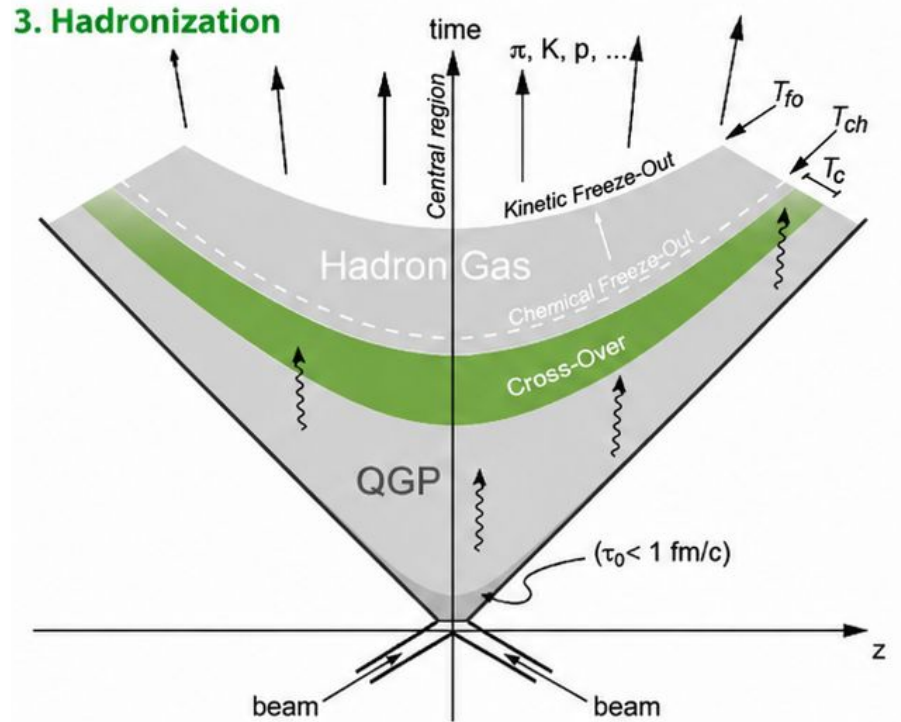

How to create the QGP in laboratory?

Pre-equilibrium: production of deconfined quarks and gluons + production particles with $p_T > 1 \text{ GeV}/c$

Thermalization: system rapidly expands and begins to convert into hadron gas. **Mixed phase**

Hadronization: QGP quarks and gluons condensate in new hadrons.
QGP matter flavour composition fixed when hadrons stop to interact: **chemical freeze-out**

Chemical and kinetic freeze-out: elastic scatterings between hadrons cease + kinematical spectra become fixed

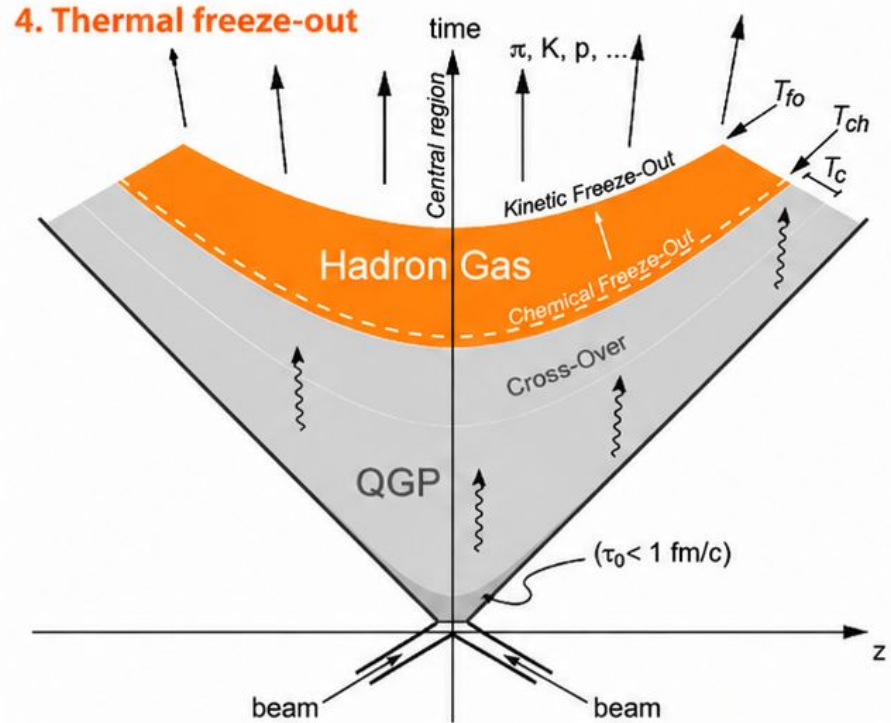

Probing the QGP with quarkonia

Heavy quarks (charm c and beauty b):

- ❖ Produced in **initial** hard partonic **scattering**

Quarkonium:

- ❖ **Bound states** of **heavy-quark pairs** (charmonium $c\bar{c}$, bottomonium $b\bar{b}$)
- ❖ Produced in a two-stage process:
 - heavy-quark production (pQCD, $gg \rightarrow q\bar{q}$)
 - subsequent bound-state formation (non-perturbative QCD)
- ❖ Sensitive to medium produced in heavy-ion collisions

J/ψ

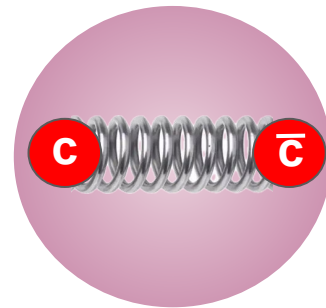

$\psi(2S)$

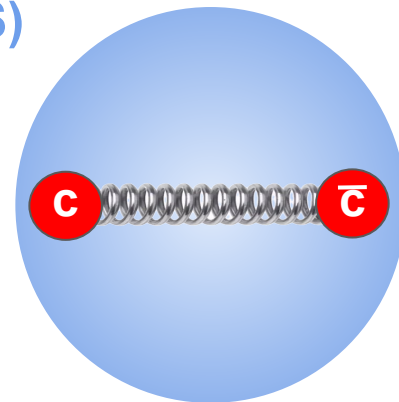

Physics motivation

At LHC energies in Pb–Pb, hot nuclear matter effects, such as **quarkonium suppression** (color screening[1]) and **regeneration** (enhanced cc production [2,3]) are expected.

Studying $\psi(2S)$ and J/ψ production in Pb–Pb collisions provides insight into QGP properties through their **different suppression** and **recombination** dynamics.

Quarkonium sequential suppression:

❖ \neq quarkonium states $\rightarrow \neq$ dissociation temperatures

Quarkonium regeneration [2,3]:

- ❖ Enhanced cc pair production at LHC energies
- ❖ **Recombination of uncorrelated heavy-quarks pairs**

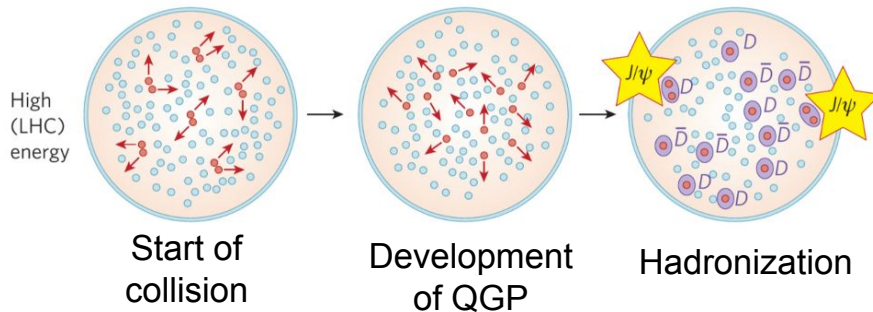
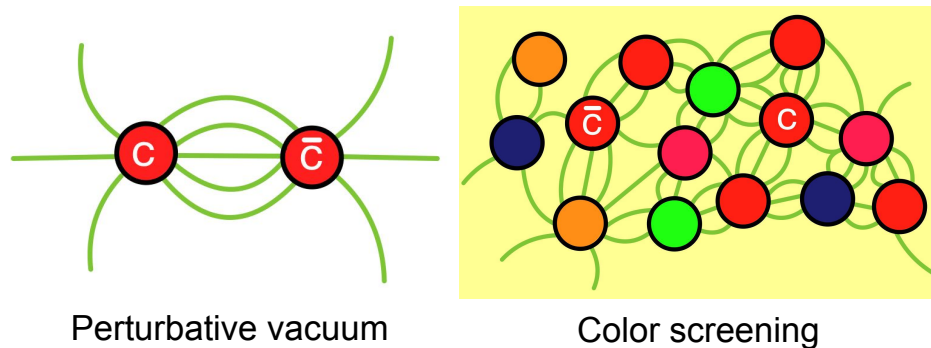

[1] T. Matsui and H. Satz, *Phys. Lett. B* 178 (1986) 416

[2] P. Braun-Munzinger et al., *PLB* (2001) 518

[3] R. L. Thews et al., *PRC* 63 (2001) 054905

ALICE Run 3

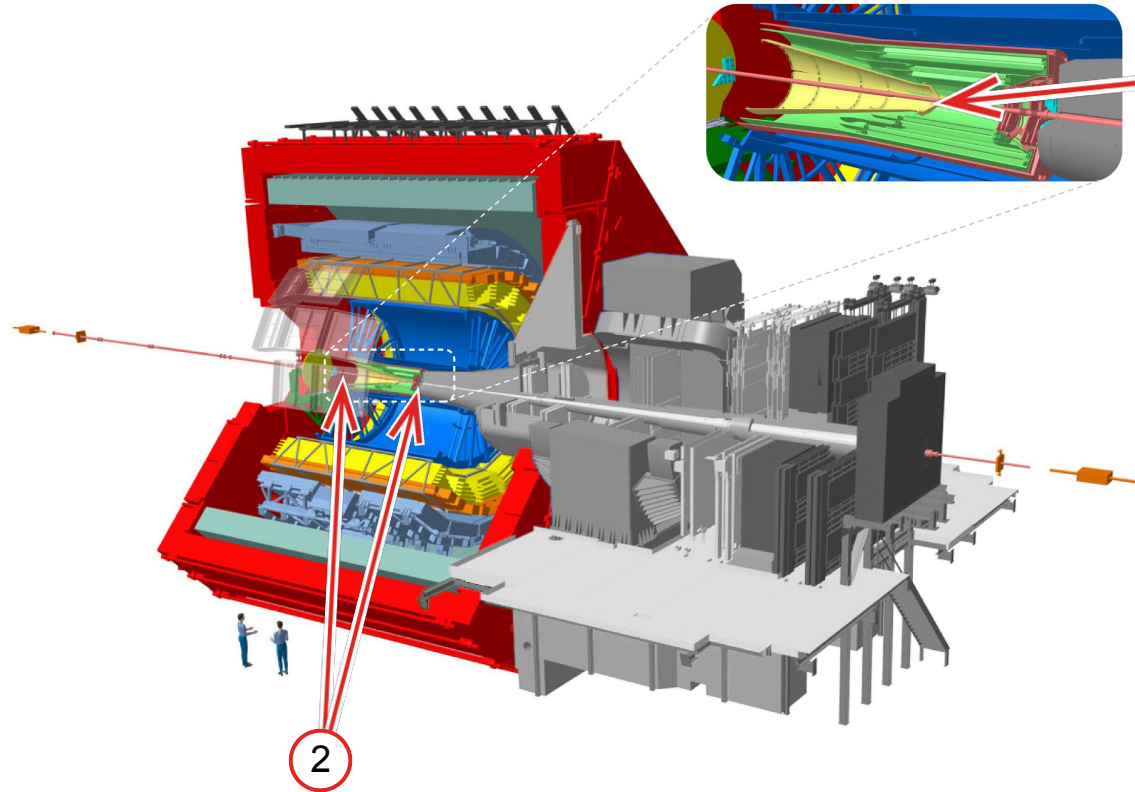

① **ITS** | Inner Tracking System
Used for tracking and vertexing

② **FT0** | detectors
Centrality estimation

ALICE Run 3

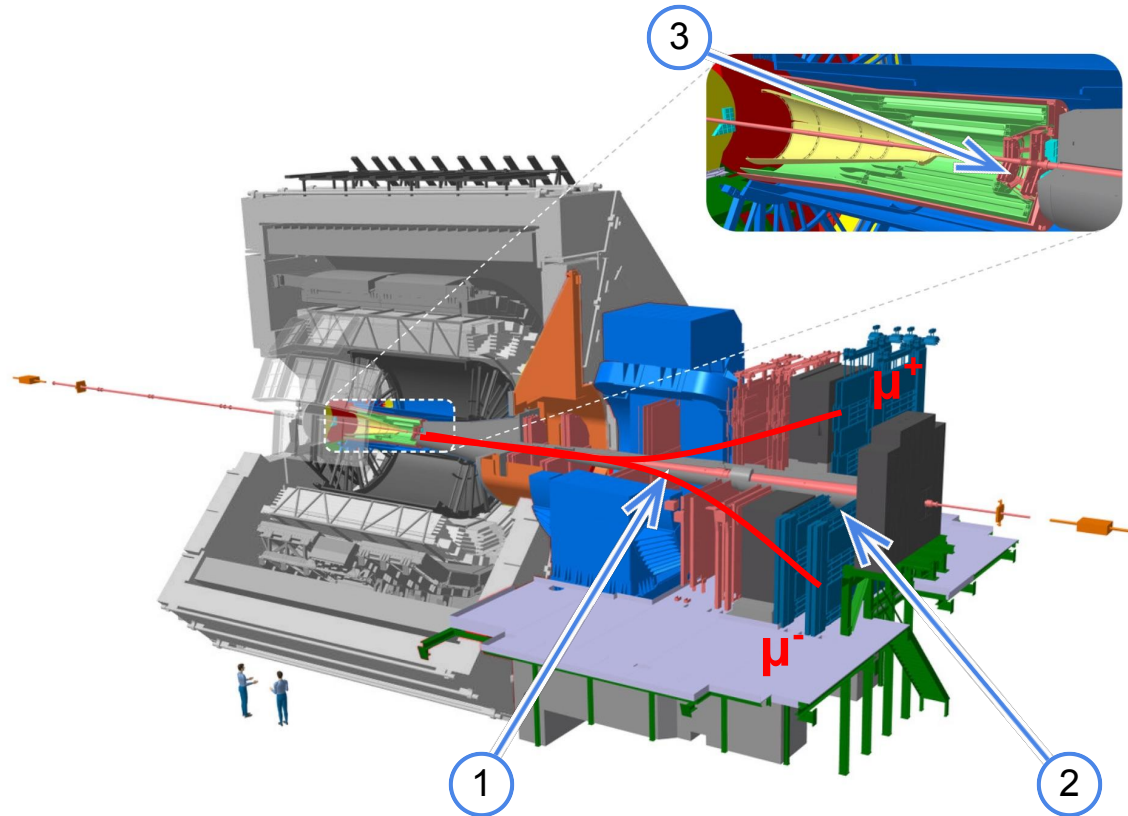

1 **MCH** | Muon Chambers
Used to reconstruct muons
 $-4 < \eta < -2.5$

2 **MID** | Muon Identifier
Used to identify muons
 $-4 < \eta < -2.5$

3 **MFT** | Muon Forward Tracker
Improves tracking and vertex finding (not used for this analysis)
 $-3.6 < \eta < -2.5$

Analysis procedure

To measure the $\psi(2S)$ -to- J/ψ ratio:

$$\frac{BR * \sigma_{\psi(2S)}}{BR * \sigma_{J/\psi}} = \frac{N_{\psi(2S)} / Ax \epsilon_{\psi(2S)}}{N_{J/\psi} / Ax \epsilon_{J/\psi}}$$

1) Signal extraction:

- ❖ After event selection, data processed to obtain **opposite-sign dimuon** invariant-mass spectra

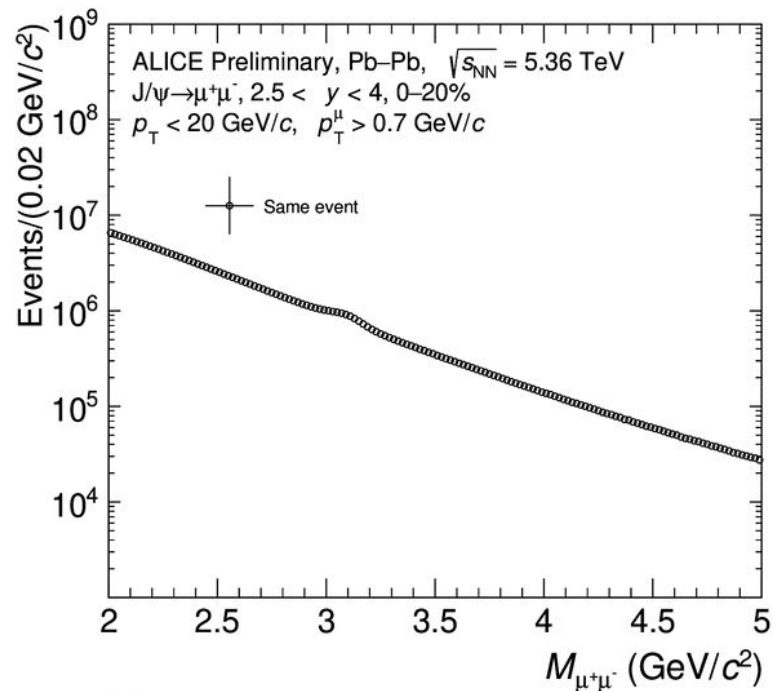

ALI-PREL-605344

Analysis procedure

To measure the $\psi(2S)$ -to- J/ψ ratio:

$$\frac{BR * \sigma_{\psi(2S)}}{BR * \sigma_{J/\psi}} = \frac{N_{\psi(2S)} / Ax \epsilon_{\psi(2S)}}{N_{J/\psi} / Ax \epsilon_{J/\psi}}$$

1) Signal extraction:

- ❖ After event selection, data processed to obtain **opposite-sign dimuon** invariant-mass spectra
- ❖ To reproduce **combinatorial background** shape: **mixed-events spectra normalized** (ME)

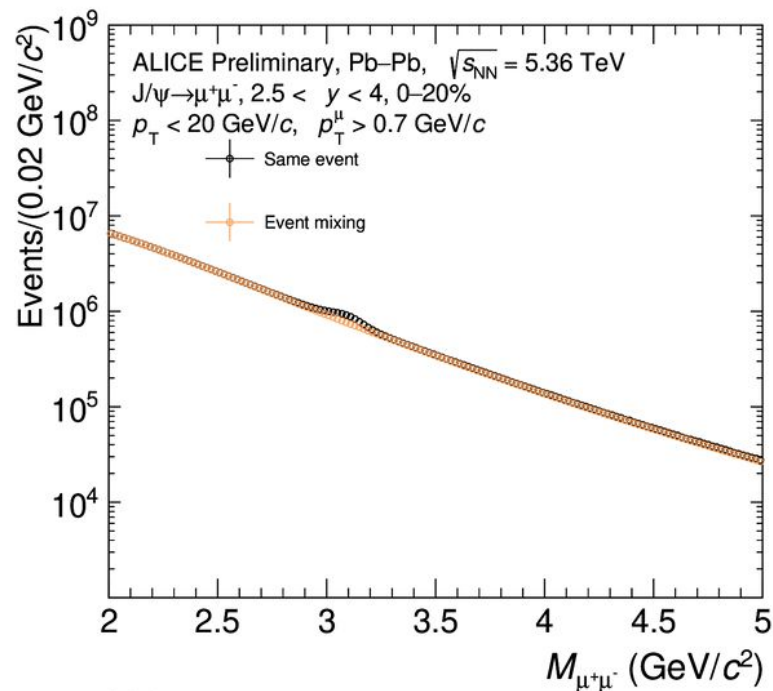
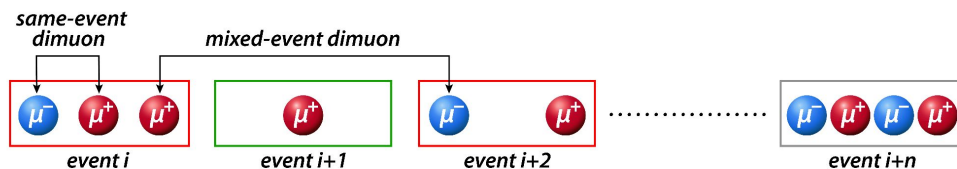

ALI-PREL-605349

Analysis procedure

To measure the $\psi(2S)$ -to- J/ψ ratio:

$$\frac{BR * \sigma_{\psi(2S)}}{BR * \sigma_{J/\psi}} = \frac{N_{\psi(2S)} / Ax \epsilon_{\psi(2S)}}{N_{J/\psi} / Ax \epsilon_{J/\psi}}$$

1) Signal extraction:

- ❖ After event selection, data processed to obtain **opposite-sign dimuon invariant-mass spectra**
- ❖ To reproduce **combinatorial background** shape: **mixed-events spectra normalized** (ME)
- ❖ **Subtract** from **opposite-sign invariant-mass spectra** the normalized ME spectra
- ❖ Determine **J/ψ** and **$\psi(2S)$ yields** by fitting subtracted spectra using various **signal + background** functions

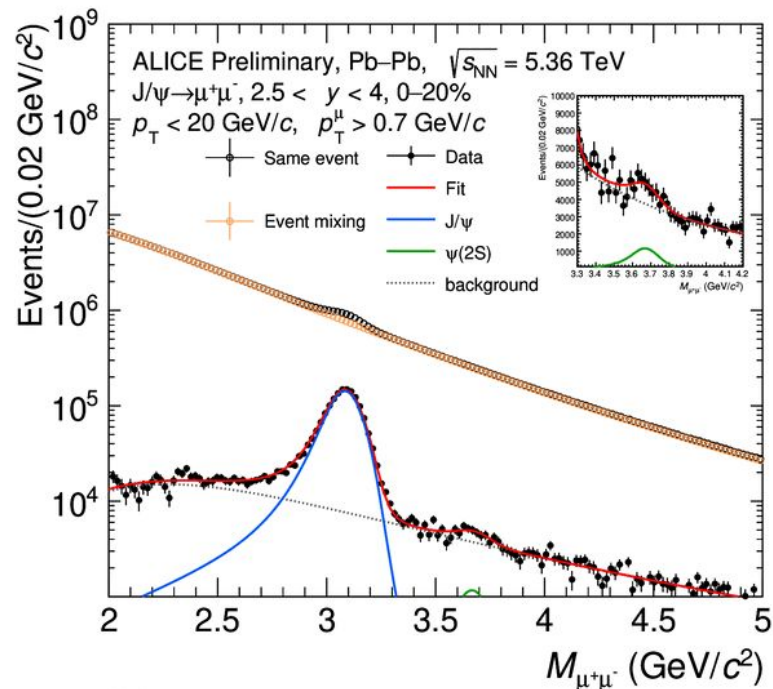

ALI-PREL-599781

Analysis procedure

To measure the $\psi(2S)$ -to- J/ψ ratio:

$$\frac{BR * \sigma_{\psi(2S)}}{BR * \sigma_{J/\psi}} = \frac{N_{\psi(2S)} / Ax\epsilon_{\psi(2S)}}{N_{J/\psi} / Ax\epsilon_{J/\psi}}$$

- 1) Signal extraction
- 2) **Estimate** the **detectors $Ax\epsilon$** using the **MC**:
 - a) MC input kinematics tuned on real data from previous measurements
 - b) Charmonium signals injected in Pythia 8
- 3) **Correct** the ratio $N_{\psi(2S)}/N_{J/\psi}$ by **$Ax\epsilon$** obtaining $BR\sigma_{\psi(2S)}/BR\sigma_{J/\psi}$

$\psi(2S)$ -to- J/ψ relative suppression

What should we observe without $\psi(2S)$ -to- J/ψ relative suppression?

- ❖ $\psi(2S)$ rescaled according to what we should expect without QGP formation (as in pp collisions)
- ❖ Extrapolated ratio in pp at energy of $\sqrt{s} = 5.36$ TeV [6]
- ❖ $\psi(2S)$ relative suppression observed to be a factor ~ 2 less than in rescaled pp collisions

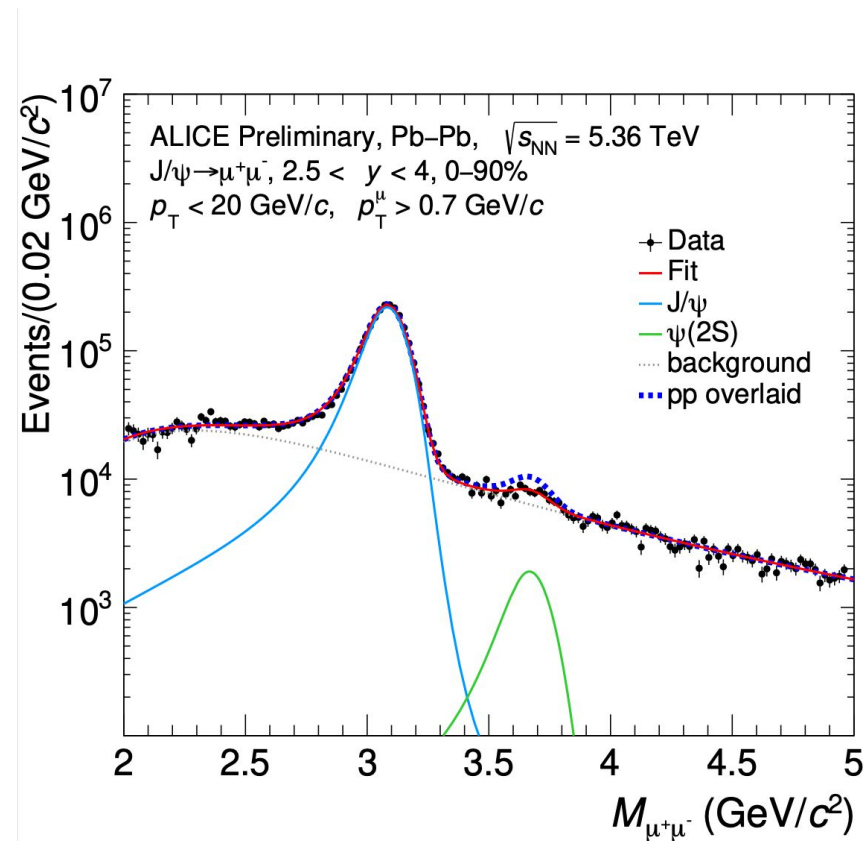

ALI-PREL-600511

$\psi(2S)$ -to- J/ψ ratio as a function of centrality and p_T

- ❖ The ratio has been computed vs centrality and p_T
- ❖ Ratio vs centrality and $p_T \rightarrow$ **no significant dependence** within the uncertainties

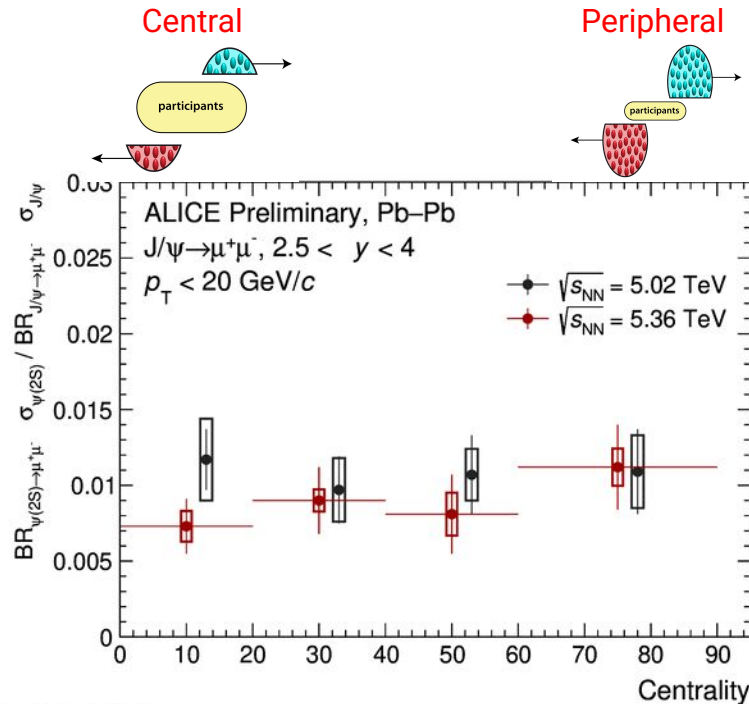

ALI-PREL-599761

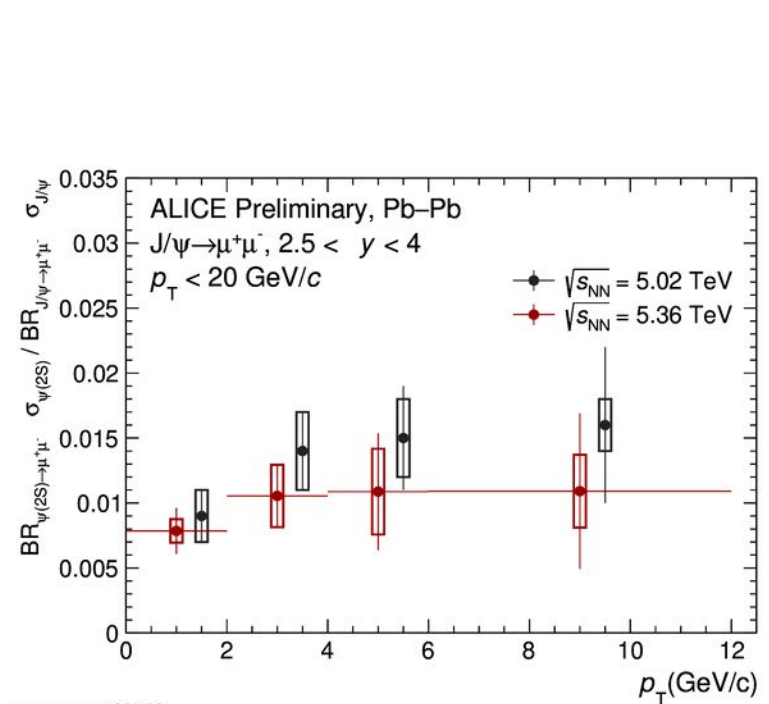

ALI-PREL-599766

$\psi(2S)$ -to- J/ψ ratio as a function of centrality and p_T

Comparison with Run 2:

- ❖ Run 2 points are shifted to better see the results
- ❖ **Run 3** has the **same binning as Run 2** both in p_T and centrality
- ❖ **Results** obtained in **Run 3** in **good agreement** with the ones obtained in **Run 2!**

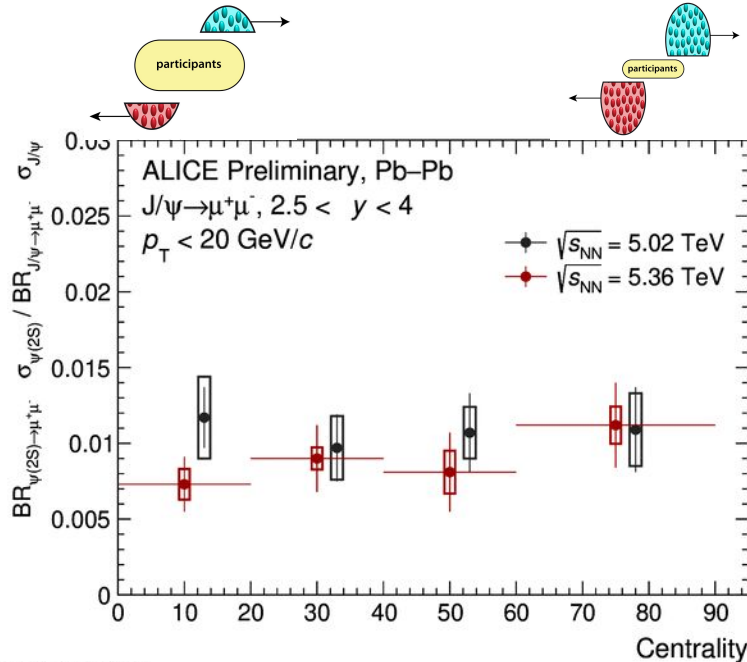

ALI-PREL-599761

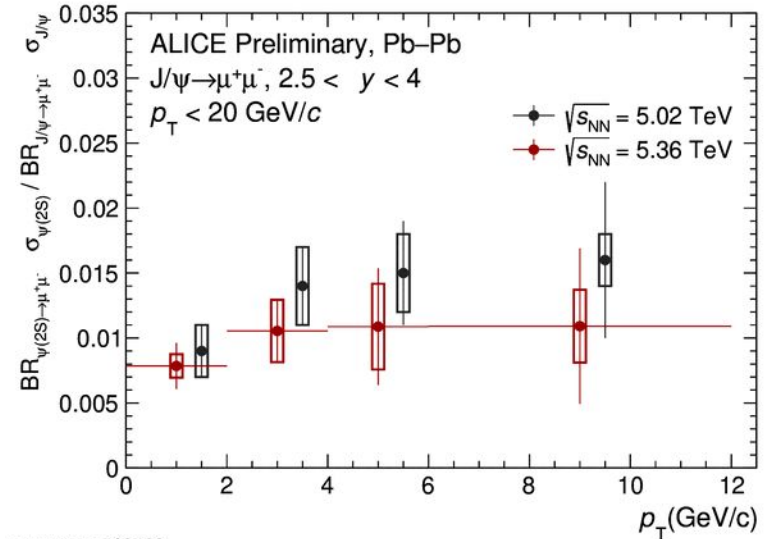

ALI-PREL-599766

$\psi(2S)$ -to- J/ψ ratio as a function of centrality and p_T

Comparison with:

- ❖ **TAMU model:** hierarchic suppression of charmonia in the QGP + regeneration [7]
- ❖ **SHMc:** no quarkonium survive in the QGP \rightarrow charm recombination at chemical freeze-out [8]

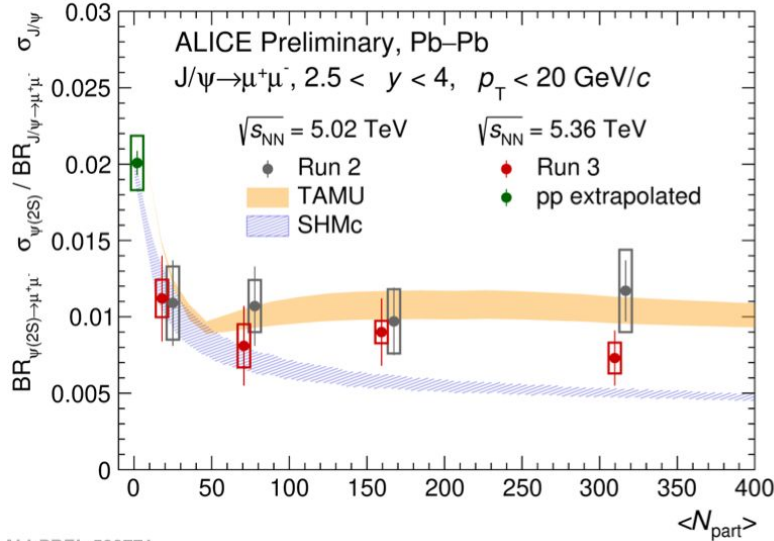

ALI-PREL-599771

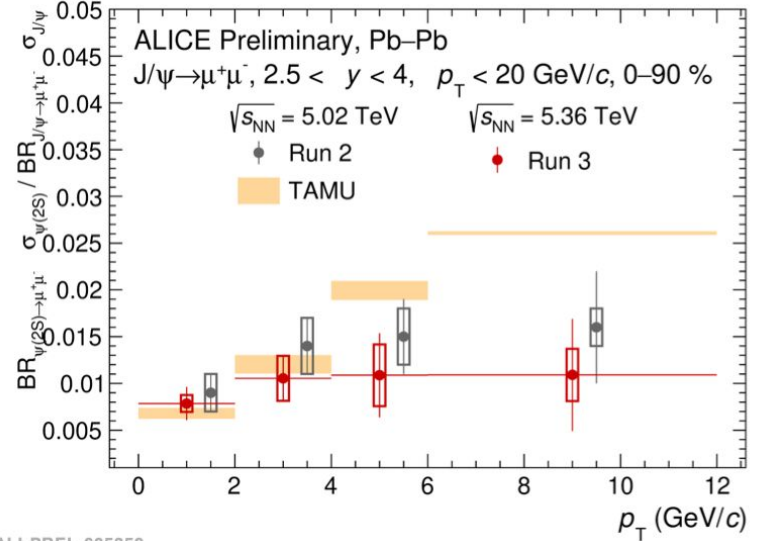

ALI-PREL-605359

[7] R. RAPP, NPA 943 (2015) 147

[8] A. ANDRONIC, PLB 797 (2019) 134836

Light ion collisions

- At LHC we don't only collide Pb-Pb but also OO ions
- In 2025 we had a very successful OO data taking
- Theoretical models (TAMU, SHM) predict a rapid evolution of the $\psi(2S)/J/\psi$ ratio from pp to peripheral Pb-Pb

OO allows one to probe quarkonium behavior in a medium characterized by intermediate conditions between Pb-Pb and pp collisions

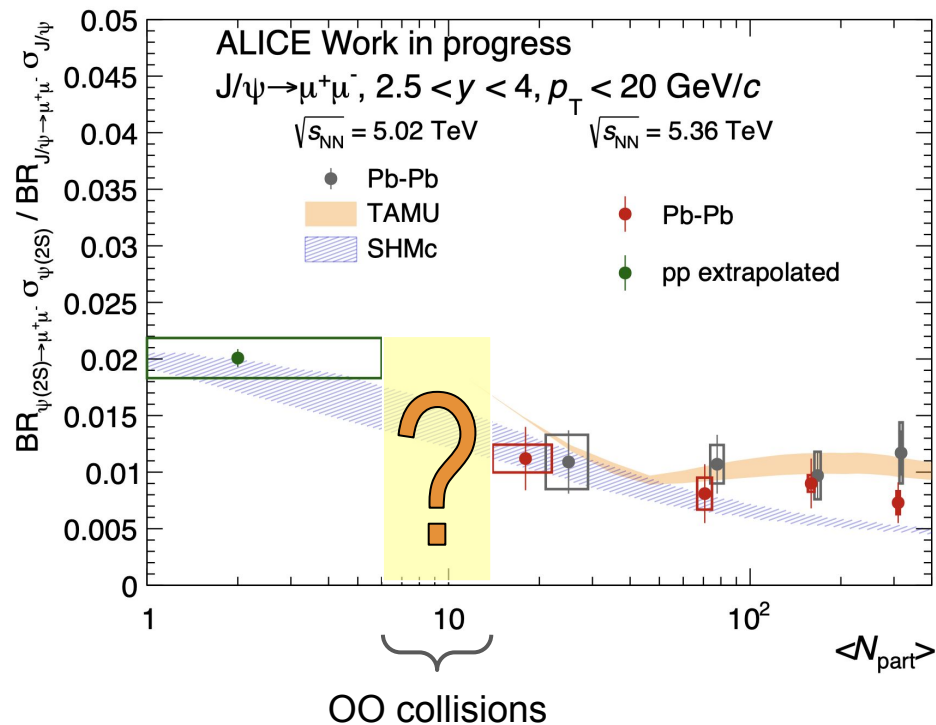

Measurement of the $\psi(2S)$ -to- J/ψ ratio in OO

To measure the $\psi(2S)$ -to- J/ψ ratio:
$$\frac{BR * \sigma_{\psi(2S)}}{BR * \sigma_{J/\psi}} = \frac{N_{\psi(2S)} / Ax\epsilon_{\psi(2S)}}{N_{J/\psi} / Ax\epsilon_{J/\psi}}$$

Same procedure as Pb-Pb

1) Signal extraction:

- ❖ Normalize the mixed events (ME) spectra
- ❖ Subtract from opposite-sign invariant mass spectra the normalized ME spectra
- ❖ Determine J/ψ and $\psi(2S)$ yields by fitting subtracted spectra (48 trials) using various signal + background functions

2) Estimate the detectors $Ax\epsilon$ using the MC

3) Correct the ratio $N_{\psi(2S)} / N_{J/\psi}$ by $Ax\epsilon$ obtaining

$$BR\sigma_{\psi(2S)} / BR\sigma_{J/\psi}$$

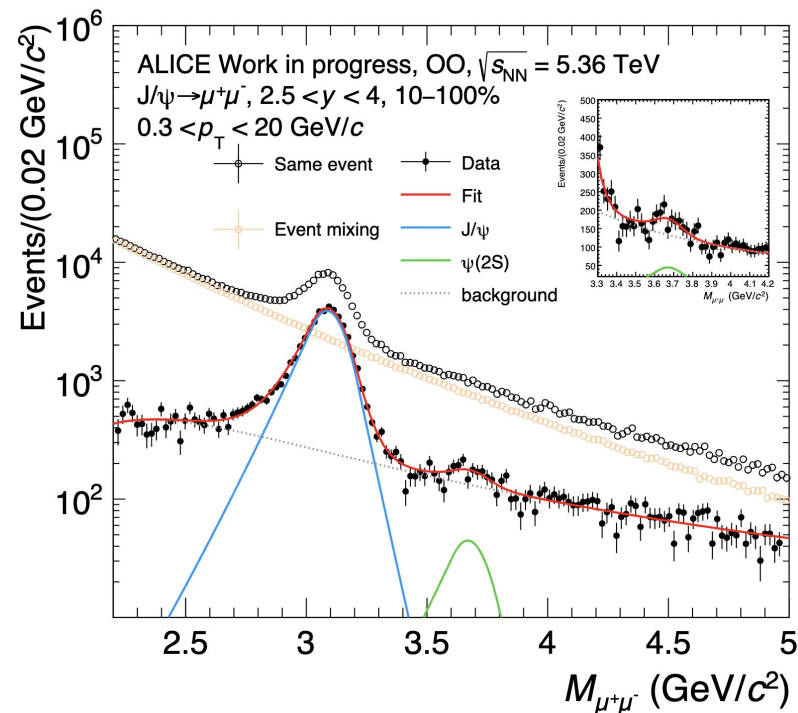

$\psi(2S)$ -to- J/ψ ratio

❖ Systematics box on x axis is arbitrary large

- ❖ Theoretical models (TAMU, SHM) predict a rapid evolution of the $\psi(2S)/J/\psi$ ratio from pp to peripheral Pb-Pb
- ❖ The ratio in OO is compatible with what is obtained for peripheral Pb-Pb collisions and lower in pp by $\sim 1.93 \sigma$

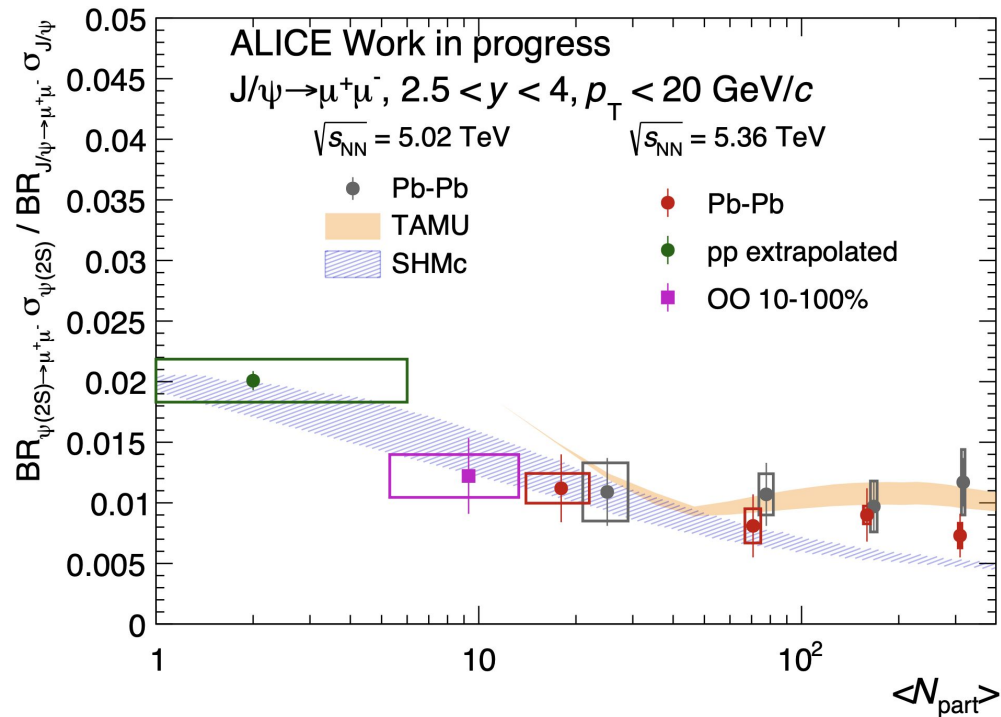

Thanks for your attention!